

# 4-54 1975-79 DISTRIBUTORS & IGNITION SYSTEMS

## Motorcraft EEC Ignition

Ford, Mercury, Lincoln Versailles

### DESCRIPTION

All Lincoln Versailles models are equipped with Electronic Engine Control I (EEC I). Some Ford and Mercury 351" W engines are equipped with Electronic Engine Control II (EEC II). The EEC systems consist of an Electronic Control Assembly (ECA), various sensors, and modified Dura-Spark II (Dura-Spark III on EEC II) ignition module and coil.

The distributor used with the EEC systems does not use a pick-up coil, armature, or any vacuum or mechanical advance mechanisms. All ignition timing is controlled by the ECA based on engine operating conditions as sensed by sensors. The ECA is capable of firing the spark plugs at any point from TDC to 60 degrees (50 degrees on EEC II) before top dead center.

**NOTE:** For additional information on EEC I or EEC II systems, see appropriate article in **COMPUTERIZED ENGINE CONTROLS** section.

### OPERATION

#### ELECTRONIC CONTROL ASSEMBLY (ECA)

The ECA is a solid-state micro-computer, consisting of a processor assembly and a calibration assembly. The ECA is located under left side of instrument panel, just left of steering column. See Fig. 1. The ECA does not include a self-diagnostic function.

**Processor Assembly** – Housed in an aluminum case, this assembly continuously samples the 7 sensor signals and converts them to a usable signal for the computer. It also performs ignition timing, Thermactor and EGR flow calculations, and sends the proper electrical signal to the ignition module, EGR and Thermactor air control solenoids to adjust the timing and flow rates as required.

**Calibration Assembly** – This is the "memory" unit of the ECA. It provides calibration information for the ECA, stores the "best mode" information, and sends it out when required.

If the calibration assembly should fail, the engine operates with spark advance held constant at 10°BTDC. The EGR and Thermactor systems are deactivated. This allows operation of the vehicle, with reduced performance, until repairs can be made.

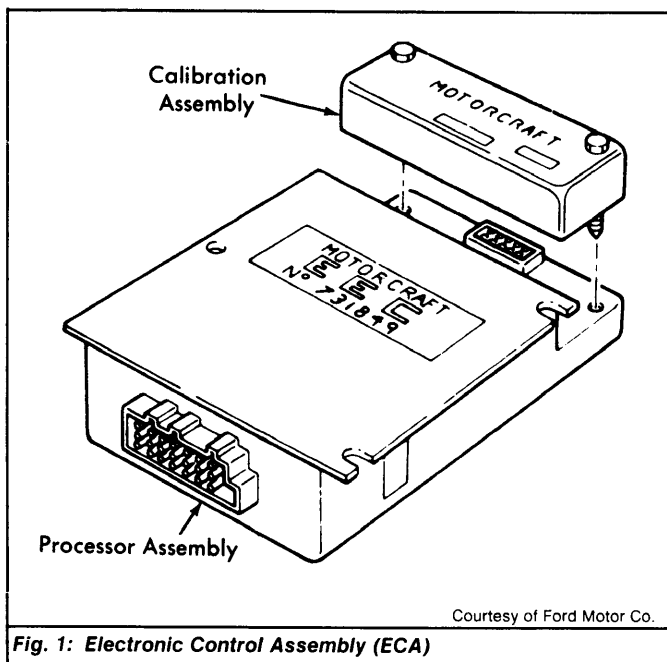

Fig. 1: Electronic Control Assembly (ECA)

#### ECA POWER RELAY

The ECA power relay supplies battery voltage to the EEC I system, and protects the ECA from possible damage due to reversed voltage polarity. Power relay is mounted to lower, right side of the ECA bracket.

#### MANIFOLD ABSOLUTE PRESSURE (MAP) SENSOR

This sensor monitors all changes in manifold pressure resulting from engine load, speed, and atmospheric pressure variations. The ECA applies a 9-volt reference voltage to sensor and monitors resultant output voltage to determine part throttle spark advance and EGR flow rate. The MAP sensor is mounted on the left rocker arm cover.

**NOTE:** A running change was made in the 1978 EEC I system. The Barometric Pressure Sensor and the Manifold Absolute Pressure Sensor were combined in a single housing.

#### BAROMETRIC PRESSURE (BP) SENSOR

Mounted on engine compartment side of firewall, this unit senses barometric (atmospheric) pressure. The ECA applies a 9-volt reference voltage to sensor and monitors resultant output voltage. The output voltage produced is proportional to the atmospheric pressure detected by sensor. The ECA adjusts EGR flow requirements according to vehicle altitude.

#### ENGINE COOLANT TEMPERATURE (ECT) SENSOR

The Engine Coolant Temperature (ECT) sensor (thermistor) is installed at rear of intake manifold, near left rocker arm cover. The coolant temperature sensor resistance is high at low temperatures and decreases as temperature rises. The ECA applies a 9-volt reference voltage to sensor and monitors the resultant voltage drop across sensor.

If coolant temperature is less than 70°F or greater than 230°F, the ECA will cut off all EGR flow. Also, if engine coolant overheats from prolonged idle, the ECA will advance initial engine timing to increase engine speed and improve cooling.

#### INLET AIR TEMPERATURE (IAT) SENSOR

The inlet air temperature sensor is similar in construction to the coolant temperature sensor. Sensor is mounted in the air cleaner body, near inlet duct. As air temperature rises, the resistance of the sensing thermistor decreases.

The ECA applies a 9-volt reference voltage to sensor and monitors the resultant voltage drop across sensor. By this method, the ECA can determine proper spark advance and Thermactor air injection flow. At high inlet temperatures (above 90°F), the ECA will modify timing advance as necessary to prevent spark knock.

#### CRANKSHAFT POSITION (CP) SENSOR

To provide EEC system with accurate timing reference, the rear of the crankshaft is fitted with a 4-lobe pulse ring. The ring is positioned 10 degrees in advance of TDC, to set basic engine timing at 10°BTDC. The crankshaft position sensor is fitted on rear, right side of engine block.

As crankshaft rotates, the lobes of the pulse ring pass the crankshaft position sensor. The sensor's magnetic field is interrupted and an output voltage pulse is generated and sent to the ECA.

The ECA uses these pulses to determine crankshaft position for ignition timing. Since the crankshaft position sensor tells the ECA when to fire the ignition module, a defective sensor or sensor wiring can prevent the vehicle from starting.

# 1975-79 DISTRIBUTORS & IGNITION SYSTEMS 4-55

## Motorcraft EEC Ignition (Cont.)

### THROTTLE POSITION SENSOR (TPS)

This sensor is mounted on side of carburetor, and is coupled to throttle shaft. The ECA applies a 9-volt reference voltage to throttle position sensor and classifies resultant output voltage into 1 of 3 positions: closed throttle (idle or deceleration), part throttle, or wide open throttle (maximum acceleration). This information is used by ECA to determine proper amount of spark advance, EGR flow, and Thermactor air injection mode.

### EGR VALVE POSITION (EVP) SENSOR

The EGR valve position sensor is part of the EGR valve. The ECA applies a 9-volt reference voltage to sensor and monitors resultant voltage output developed by sensor. The output voltage produced is directly proportional to the EGR valve pintle position, allowing the ECA to determine EGR flow rate.

## TESTING & DIAGNOSIS

### IGNITION MODULE RUN MODE TEST

1) Insert test adapter between wiring harness and ignition module 4-pin connector. See Fig. 2. Connect a scope with an inductive pick-up to coil high tension wire. Turn ignition on and check for spark while repeatedly grounding test lead.

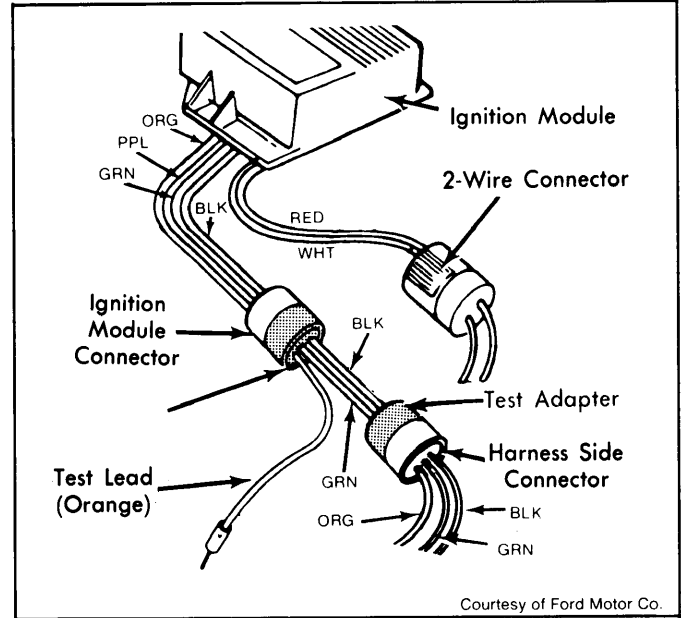

Fig. 2: EEC Ignition System Test Adapter Hook-Up

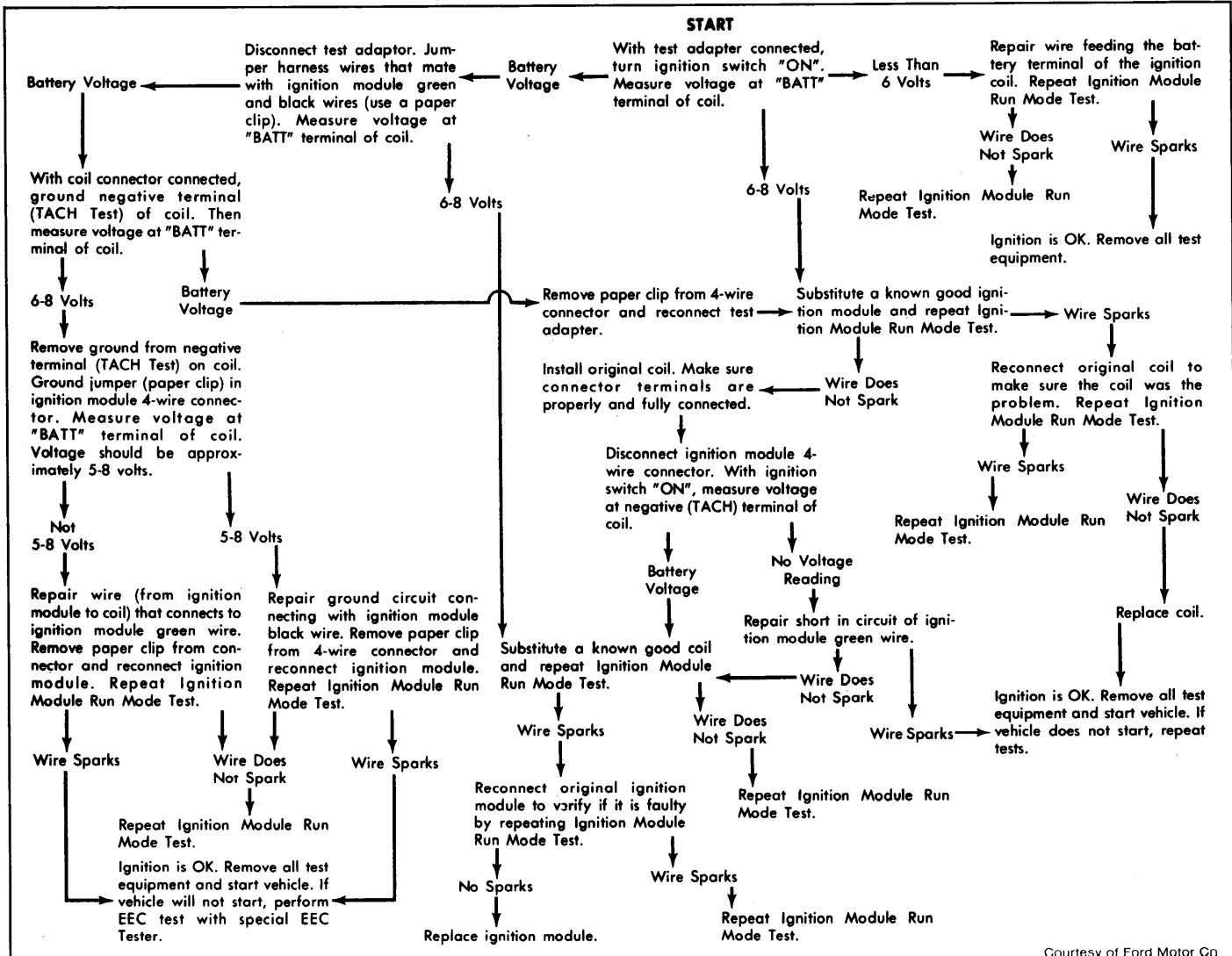

Fig. 3: Ignition Module Final Start Test Diagnostic Chart

# 4-56 1975-79 DISTRIBUTORS & IGNITION SYSTEMS

## Motorcraft EEC Ignition (Cont.)

2) If spark occurs, go to IGNITION MODULE START MODE TEST. If spark does not occur, turn ignition on and off and check for spark each time ignition is turned off. If spark occurs, go to next step. If not, to to step 4).

3) Remove test adapter. Install a known good ignition module and attempt to start engine. If engine starts, install original module to verify that unit is faulty and then replace module. If engine starts with original module, repeat test procedure.

4) Turn ignition on. Compare battery voltage with voltage at Red wire. If voltage at Red wire does not equal battery voltage, repair Red wire and attempt to start engine. If voltage at Red wire is okay or if engine does not start, go to IGNITION MODULE FINAL TEST.

### IGNITION MODULE START MODE TEST

1) With test adapter connected, crank engine and repeatedly touch diagnostic test lead to battery positive terminal and check for spark. If spark occurs, remove test equipment and attempt to start engine. If engine will not start, go to IGNITION MODULE FINAL TEST.

2) Remove test adapter and reconnect ignition module. Measure battery voltage while cranking engine. If voltages are equal, go to next step. If voltages are not equal, repair White wire and attempt to start engine. If engine does not start, go to next step.

3) Crank engine and measure voltage at coil positive terminal and at battery. If voltages are equal, go to next step. If voltages are not equal, repair wire between coil and battery. After repairs, attempt to start engine. If engine does not start, go to next step.

4) Substitute a known good ignition module and repeat IGNITION MODULE RUN MODE TEST step 1). If spark occurs, reinstall original module to verify that unit is faulty and then replace module. If spark does not occur with known good module, repeat test procedures beginning with IGNITION MODULE RUN MODE TEST.

### IGNITION MODULE FINAL START TEST

Perform ignition module final start test by following test steps outlined in diagnostic chart. See Fig. 3.

## REMOVAL & INSTALLATION

### DISTRIBUTOR

**Removal (1978 to Early 1979) - 1)** Remove distributor cap and rotate crankshaft to align distributor blade with locating slot in distributor adapter. Position rotor Alignment Key (T78P-12200A) in place.

2) Loosen distributor hold-down bolt and clamp. Remove alignment key. Slowly remove distributor from engine, noting relative position of rotor blade to distributor base when cam and distributor drive are felt to disengage.

**Installation -** Position distributor in engine. Ensure that distributor base hold-down flange is aligned with clamp bolt hole. Slot in upper blade of rotor must be aligned with slot in adapter. If not, remove and rotate distributor as necessary. See Fig. 4.

**Removal (Mid 1979 & Later) - 1)** Remove distributor cap and rotor. Rotate crankshaft to TDC timing mark. The alignment slot in sleeve assembly should be lined up with slot in adapter. See Fig. 4.

2) Remove distributor hold-down bolt and clamp. Slowly remove distributor from engine, noting relative position of sleeve and adapter slot when cam and distributor drive are felt to disengage.

**Installation - 1)** Position distributor in engine. Ensure that distributor base hold-down flange is aligned with clamp bolt hole. Slot in distributor sleeve assembly should be aligned with with slot in adapter. If not, remove and rotate distributor as necessary. See Fig. 4.

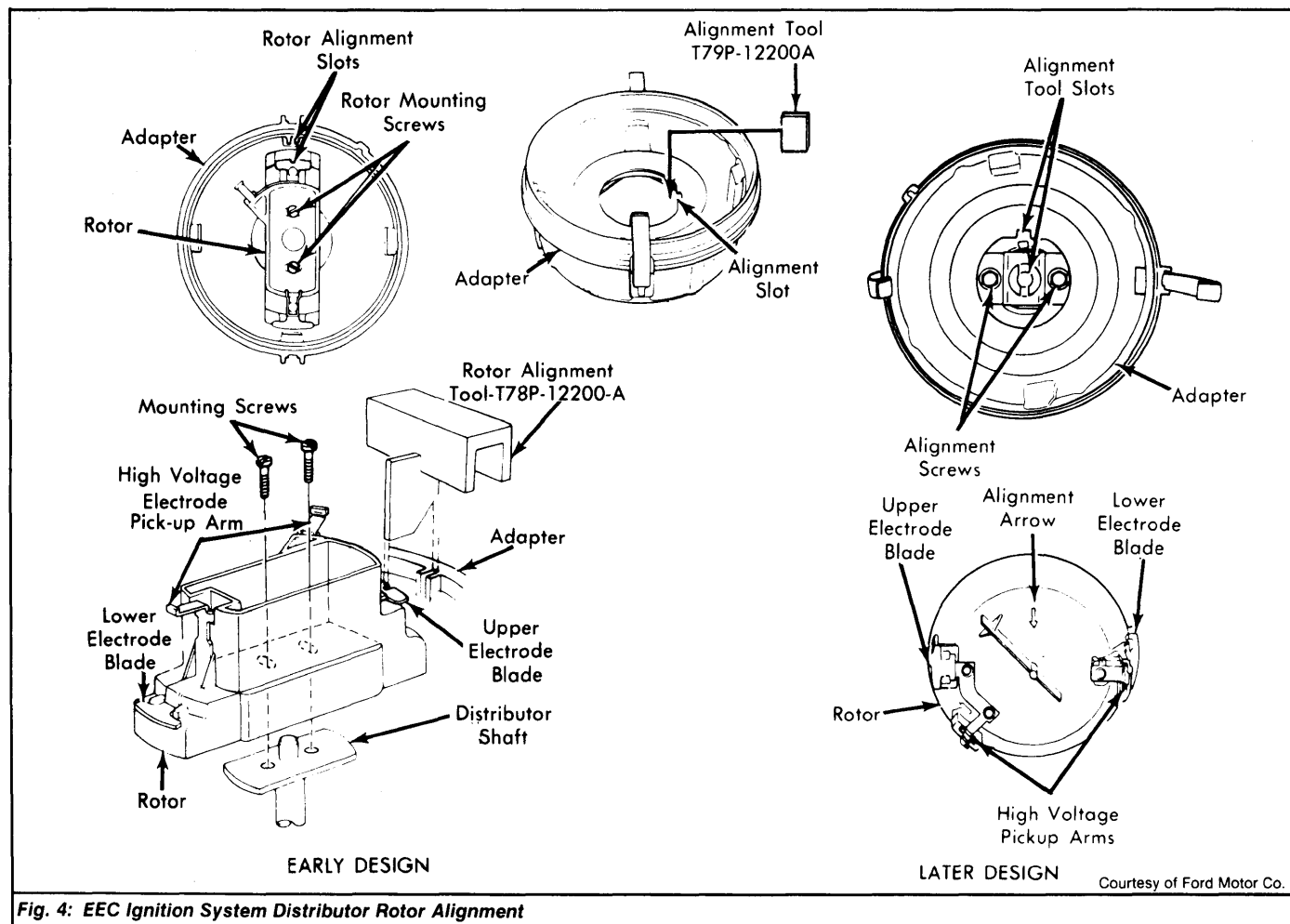

Fig. 4: EEC Ignition System Distributor Rotor Alignment