

# 4-40 1975-79 DISTRIBUTORS & IGNITION SYSTEMS Delco-Remy Electronic Spark Selection

## 1978-79 Cadillac

### DESCRIPTION

The Electronic Spark Selection (ESS) ignition system is used on Cadillac Eldorado, Seville, and California DeVille and Brougham. System is able to advance or retard spark curve under certain operating conditions. This improves fuel economy at cruising speeds, reduces exhaust emissions and improves hot engine restarting. System consists of an electronic decoder and a modified high energy ignition system distributor with a 5-pin module.

### OPERATION

The distributor pick-up coil signal is sent to the electronic decoder to provide engine speed and ignition timing information. The decoder signal is then sent to the fifth pin of the distributor 5-pin module, signalling either delay or non-delay in shutting off the current to the primary winding of the ignition coil. Maximum delay of primary winding current shutoff occurs when engine is cranking or during cold engine operation (California models only). This is also the point of maximum spark retard from normal timing.

### TESTING

**NOTE: Ignition module can only be tested by using Analyzer (J-24642) in conjunction with a voltmeter. When performing a compression test, ensure ESS system is disconnected**

### PRIMARY CIRCUIT TESTING

1) Check for correct voltage at battery terminal connector at distributor cap. Voltage should equal battery voltage in "RUN" and "START" positions.

2) To test ignition coil, remove distributor cap and wires as an assembly. Connect one ohmmeter lead to "Tach" terminal and other lead to "Bat" terminal. See Fig. 2.

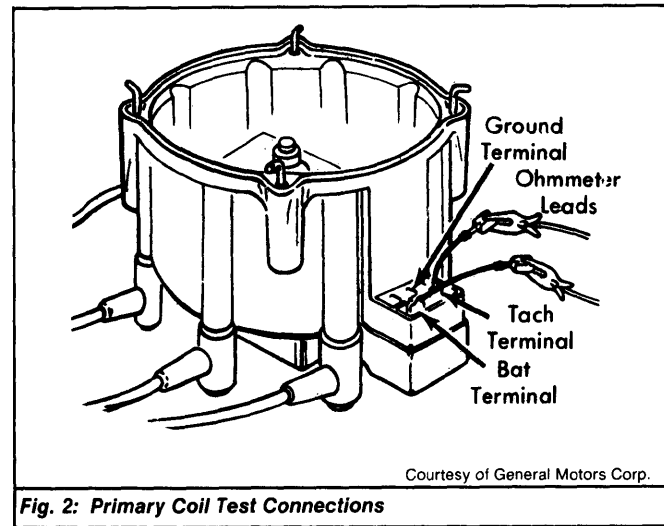

Fig. 2: Primary Coil Test Connections

3) Reading should be 0.4-1.0 ohm. Remove ohmmeter lead from "Bat" terminal and connect to ground terminal. Reading should be infinity. If either reading is not correct, replace coil.

4) Connect one ohmmeter lead to "Tach" terminal and other lead to secondary contact. See Fig. 3. Reading should be infinity. If reading is not correct, replace coil.

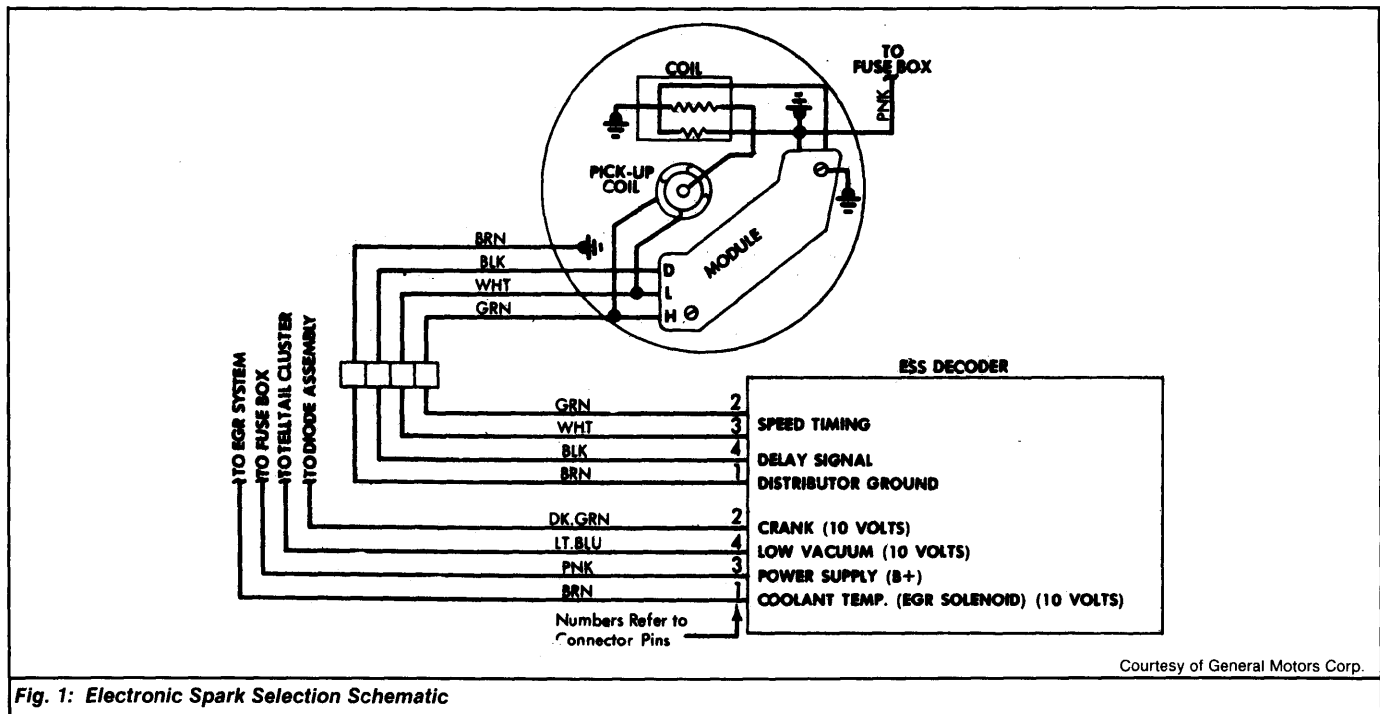

Fig. 1: Electronic Spark Selection Schematic

# 1975-79 DISTRIBUTORS & IGNITION SYSTEMS 4-41

## Delco-Remy Electronic Spark Selection (Cont.)

5) Disconnect pole piece leads from control module. Connect ohmmeter leads to the pole piece leads. See Fig. 4. Reading should be 500-1500 ohms. If not correct, replace pole piece.

6) To check for pole piece ground, remove either lead from step 5) and connect to a good ground. Reading should be infinity. If reading is not correct, replace pole piece.

7) Disconnect the Radio Frequency Interference (RFI) capacitor. Connect one ohmmeter lead to capacitor terminal and other lead to ground. See Fig. 5. Ohmmeter should move slightly, then return to infinity. Any continuous reading other than infinity indicates a bad RFI capacitor.

8) If system is still not operating properly, and all electrical connections and wiring have been checked, replace ignition control module.

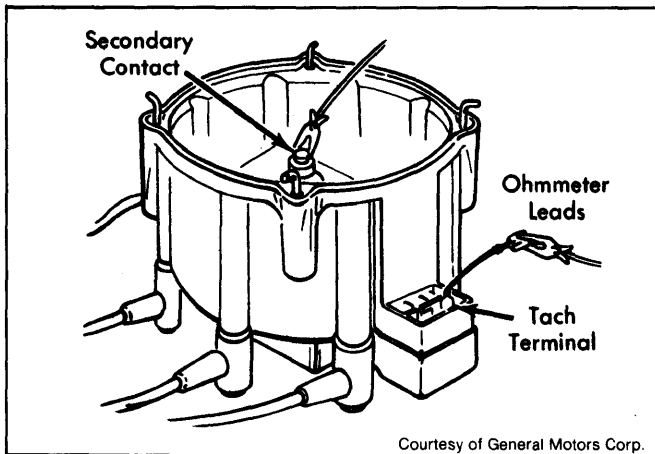

Fig. 3: Secondary Coil Test Connections

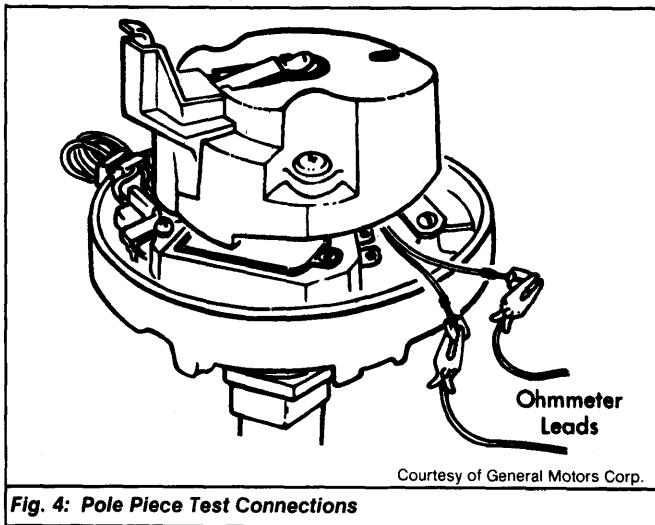

Fig. 4: Pole Piece Test Connections

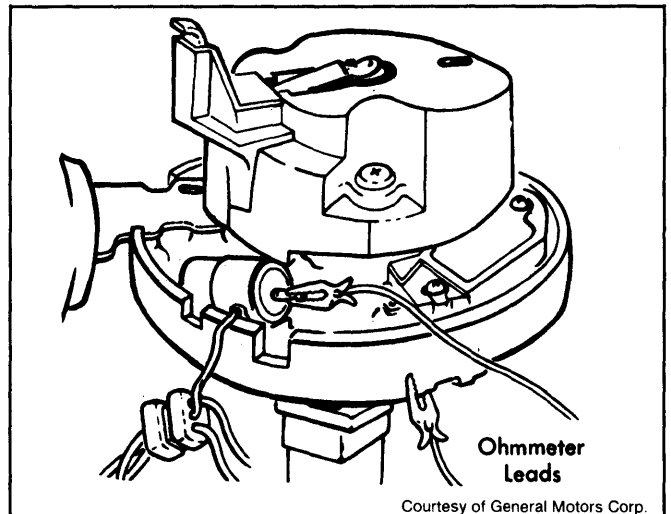

Fig. 5: RFI Capacitor Test Connections

### MODULE TEST NO. 1

1) Disconnect 3-wire connector at distributor cap. Connect Analyzer (J-24642) to module side of distributor connector. Connect analyzer ground clip to ground. Connect analyzer battery clips to battery.

2) Connect a voltmeter to analyzer 2-wire connector. Turn ignition on. Voltmeter reading should be zero volts. Press and hold test button down on analyzer. Voltmeter should read zero volts. If voltmeter indicates voltage, replace module. See Fig. 6.

3) Disconnect voltmeter. Crank engine while holding test button down on analyzer. A momentary Red light, then a continuous Green light will indicate a good module and pick-up coil. If Red light stays on, proceed to TEST NO. 2.

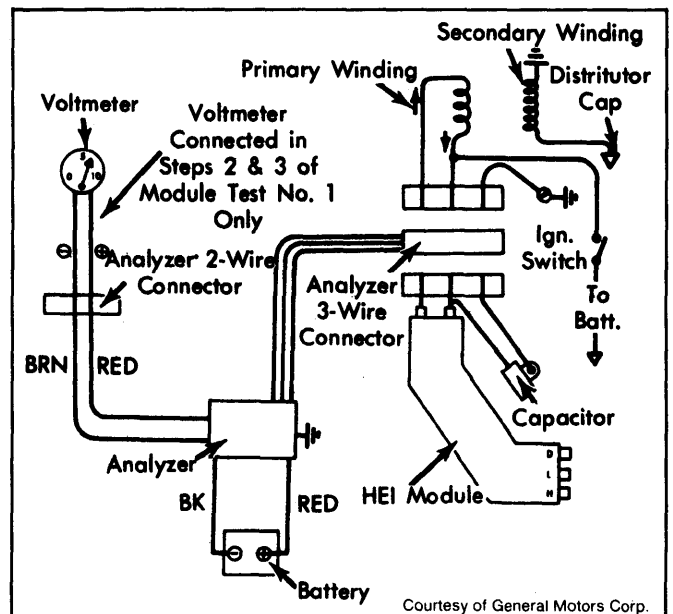

Fig. 6: Analyzer Connections for Module Test No. 1

# 4-42 1975-79 DISTRIBUTORS & IGNITION SYSTEMS Delco-Remy Electronic Spark Selection (Cont.)

## MODULE TEST NO. 2

1) Perform step 1) of MODULE (TEST NO. 1). Disconnect 4-wire connector from distributor to decoder. Connect analyzer Green clip to pin No. 2 (Green wire) that leads to module terminal H. Connect analyzer White wire clip to pin No. 3 (White wire) that leads to module terminal L. See Fig. 7.

2) Using a jumper wire, jumper between pin No. 2 (Green wire) and pin No. 4 (Black wire). Press and hold analyzer button down. A momentary Red light, then a continuous Green light indicates module is good, but pick-up coil is defective. If Red light stays on, module is defective.

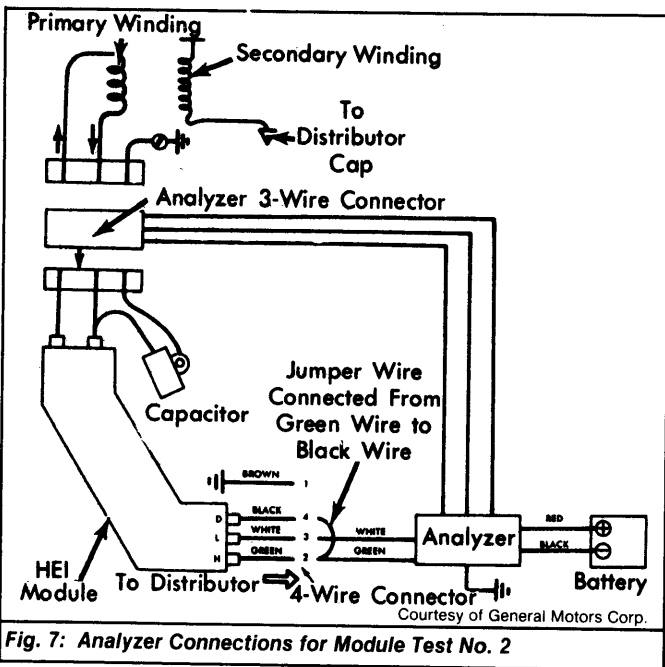

Fig. 7: Analyzer Connections for Module Test No. 2

## MODULE TEST NO. 3

1) Connect analyzer 2-pin connector to HEI module. Connect Green analyzer clip to terminal H and White clip to terminal L. Connect a jumper wire from terminal H to terminal D. Ground analyzer wire to HEI module. Connect analyzer to battery. See Fig. 8

2) Press and hold analyzer test button down. A momentary Red light, then a continuous Green light indicates module is good. If Red light stays on, module is defective.

3) Disconnect Green and White analyzer clips. Leave jumper wire connected. Connect a voltmeter to analyzer 3-wire connector. Voltmeter positive lead to Red wire and negative lead to Brown

wire. Voltmeter should read zero volts. Press and hold analyzer test button down. Voltmeter should read zero volts. If not, module is defective.

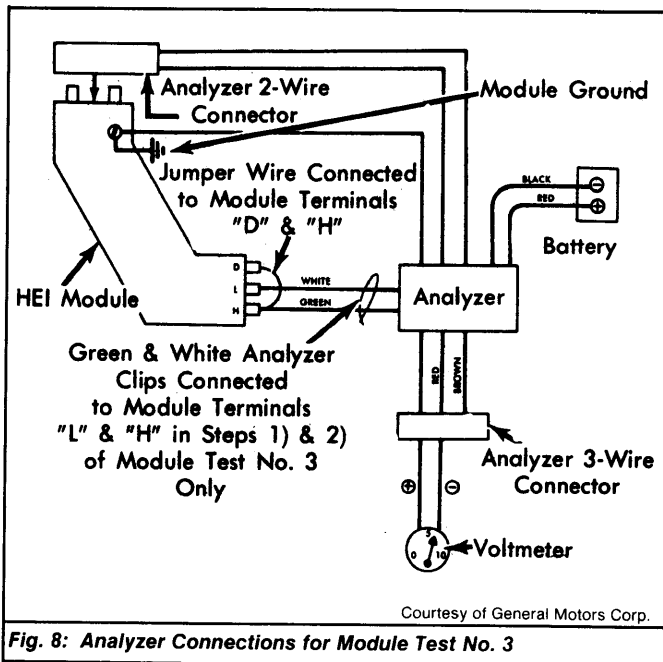

Fig. 8: Analyzer Connections for Module Test No. 3

## DECODER

1) With ignition on, check voltage at decoder 4-wire connector Pink wire. Reading should be within 2 volts of battery voltage.

2) With engine at normal operating temperature, disconnect and plug vacuum hoses at distributor and parking brake. Check ignition timing and adjust if necessary. See Emission Control Tune-Up Decal in engine compartment for specifications.

3) Disconnect 3-wire connector from EGR solenoid to decoder (Brown wire at decoder). Do not disconnect EGR solenoid 2-wire connector from manifold harness.

**NOTE: 1979 carbureted vehicle do not have EGR solenoids. Disconnect 3-wire connector to coolant temperature sensor on these vehicles.**

4) Ignition timing should retard when step 3) is performed. If not, check for open in Brown wire. If Brown wire checks okay, replace decoder. Reconnect EGR solenoid 3-wire connector (coolant temperature sensor on 1979 carbureted models).