

1977 EXHAUST EMISSION SYSTEMS

Buick Vacuum Diagrams

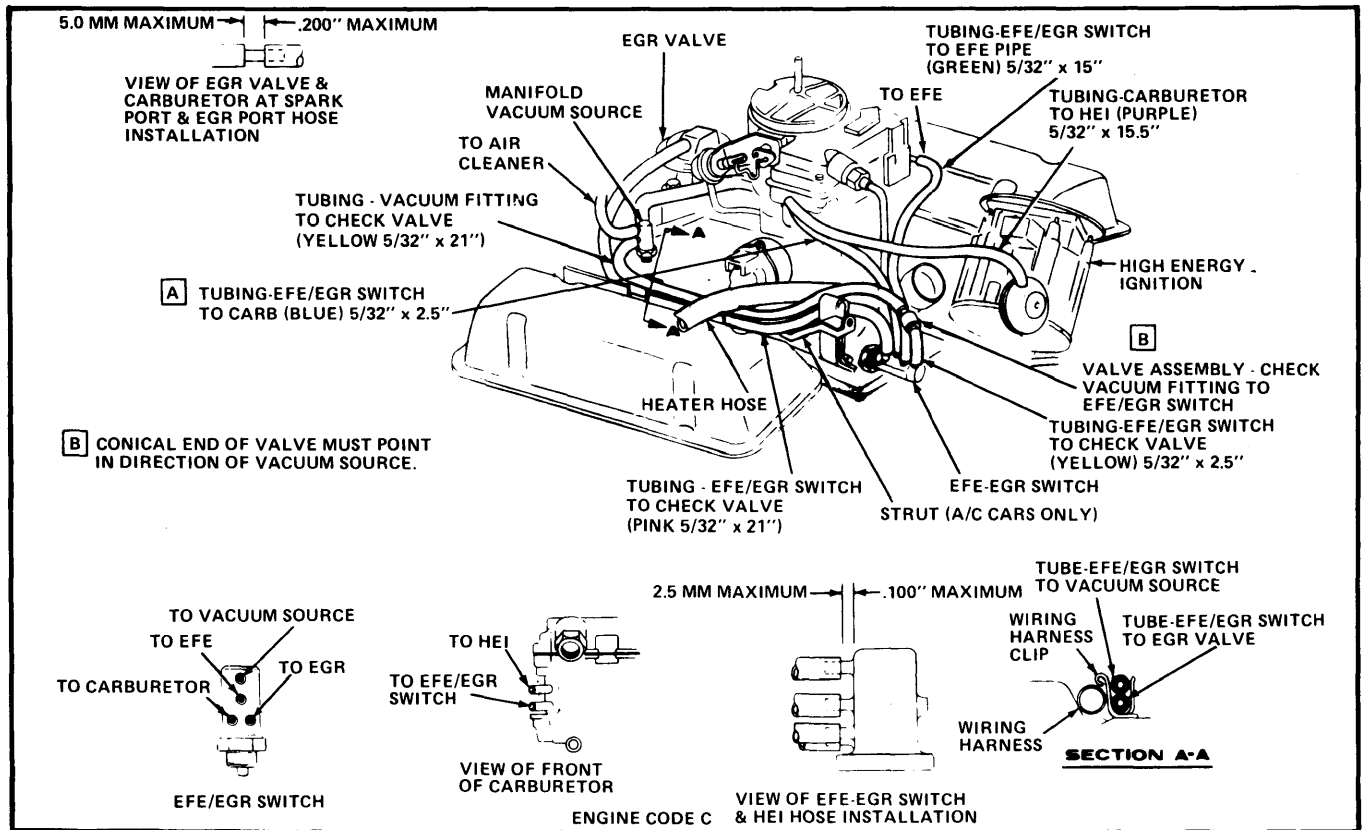

Fig. 1 231 CID Vacuum Hose Routing (Federal)

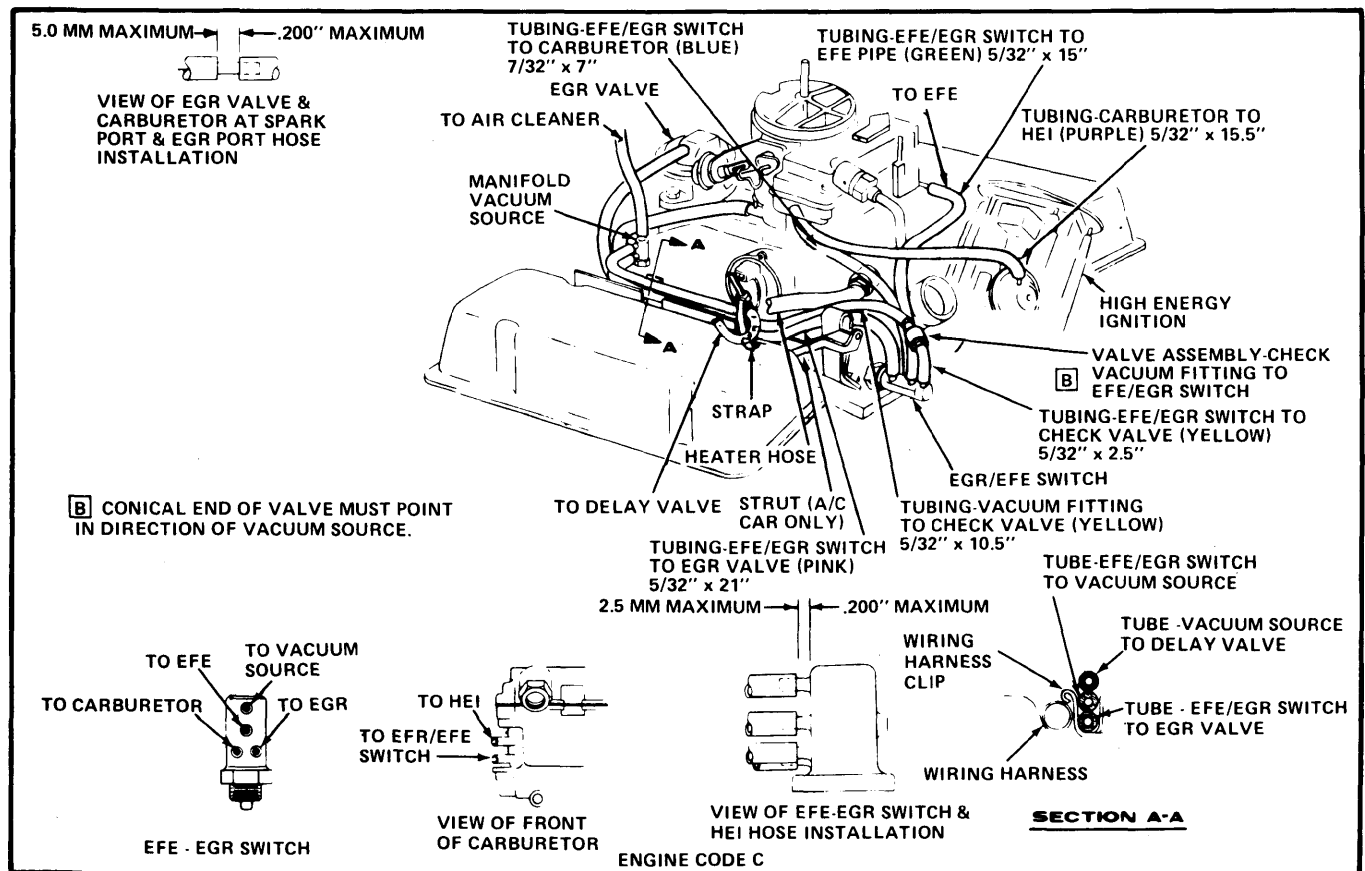

Fig. 2 231 CID Vacuum Hose Routing (High Alt. & Calif.)

1977 EXHAUST EMISSION SYSTEMS Buick Vacuum Diagrams (Cont.)

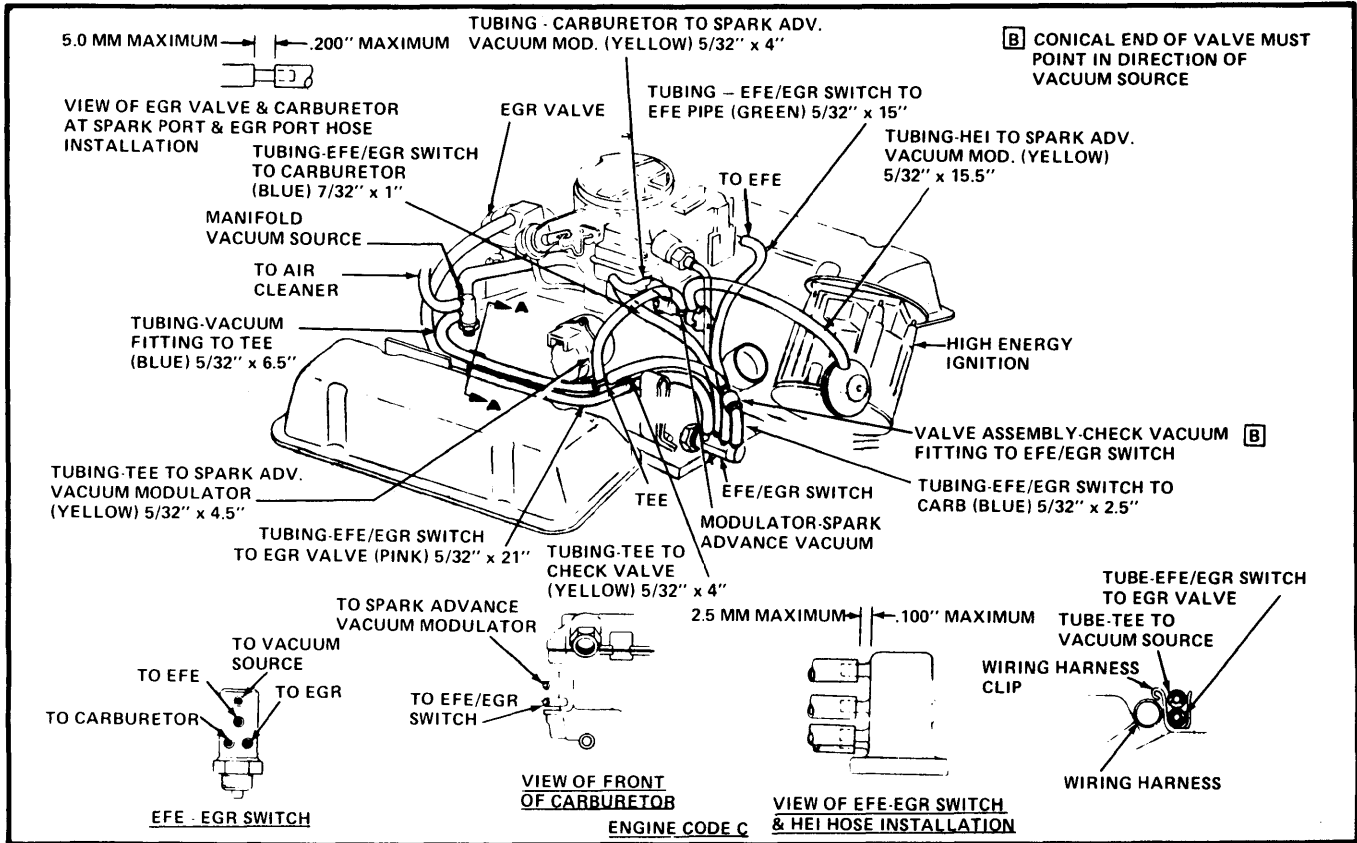

Fig. 3 231 CID "Economy Special" Vacuum Hose Routing

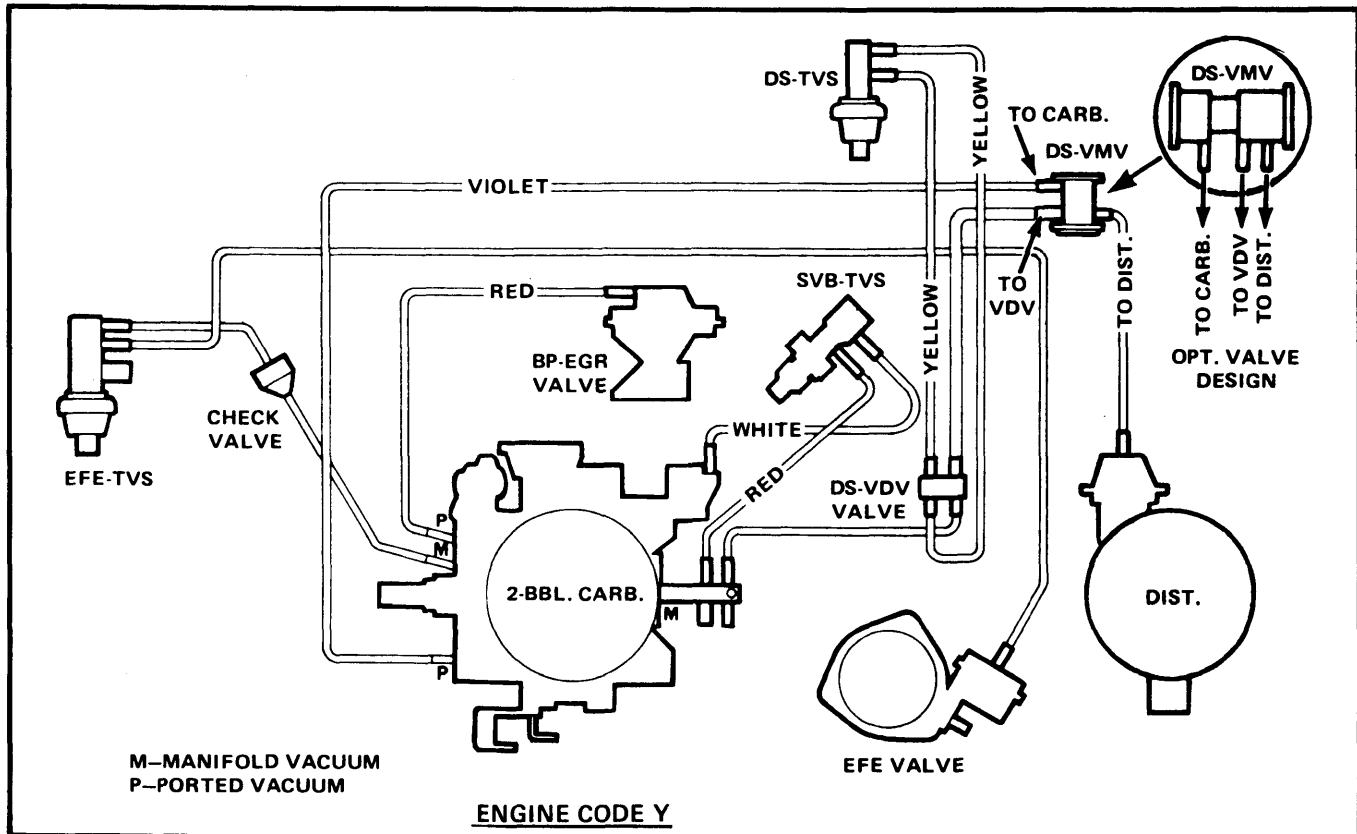

Fig. 4 301 CID Auto. Trans. with A/C Vacuum Hose Routing (Federal)

1977 EXHAUST EMISSION SYSTEMS Buick Vacuum Diagrams (Cont.)

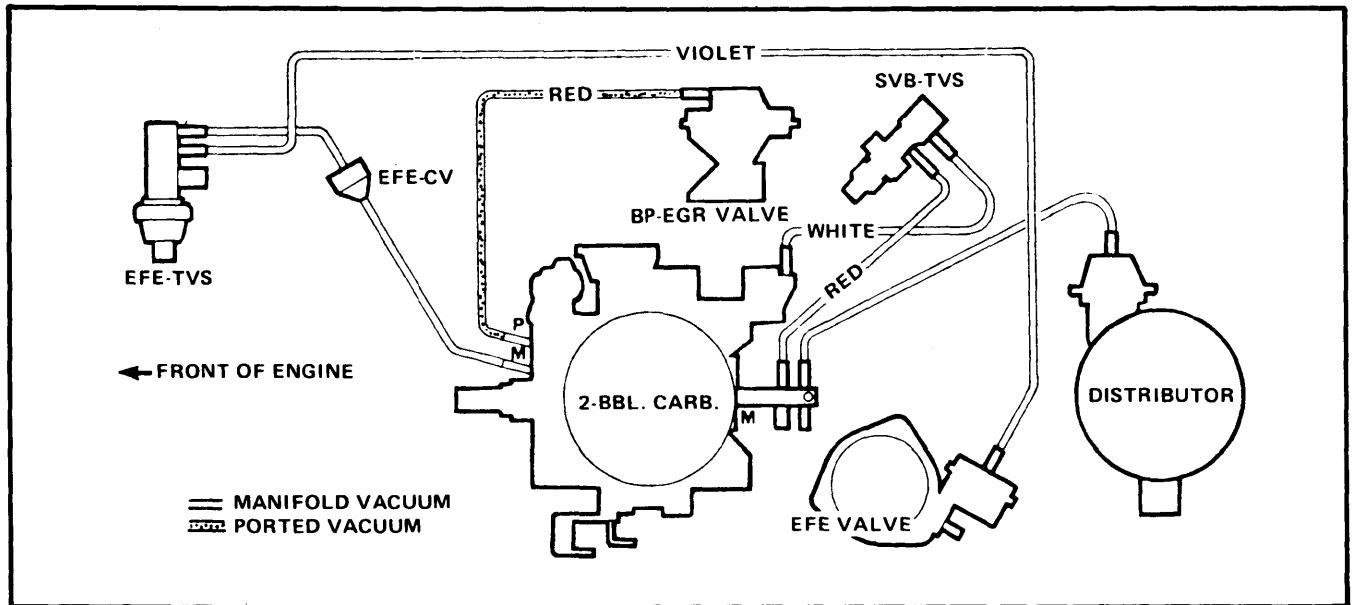

Fig. 5 301 CID Auto. Trans. without A/C Vacuum Hose Routing (Federal)

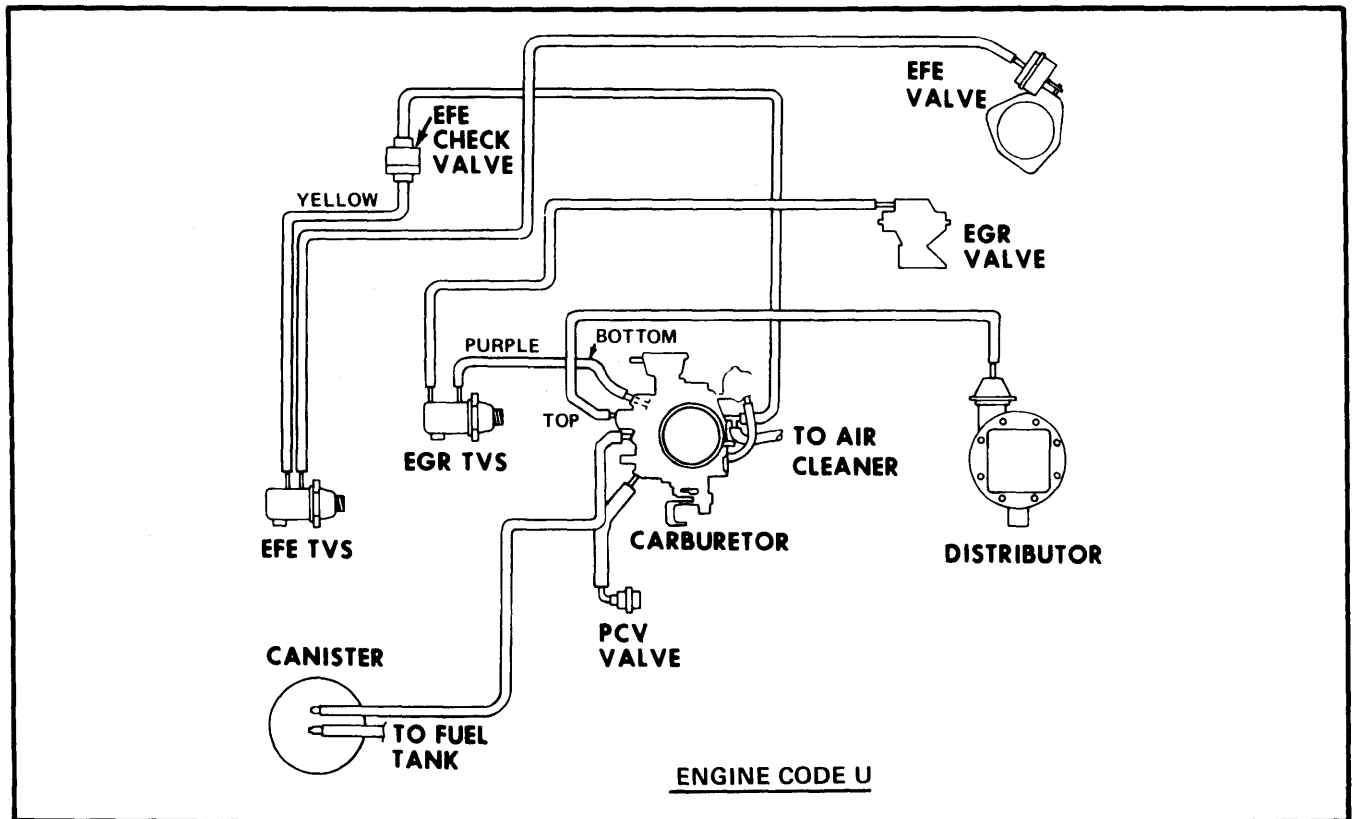

Fig. 6 305 CID Vacuum Hose Routing (Federal)

1977 EXHAUST EMISSION SYSTEMS Buick Vacuum Diagrams (Cont.)

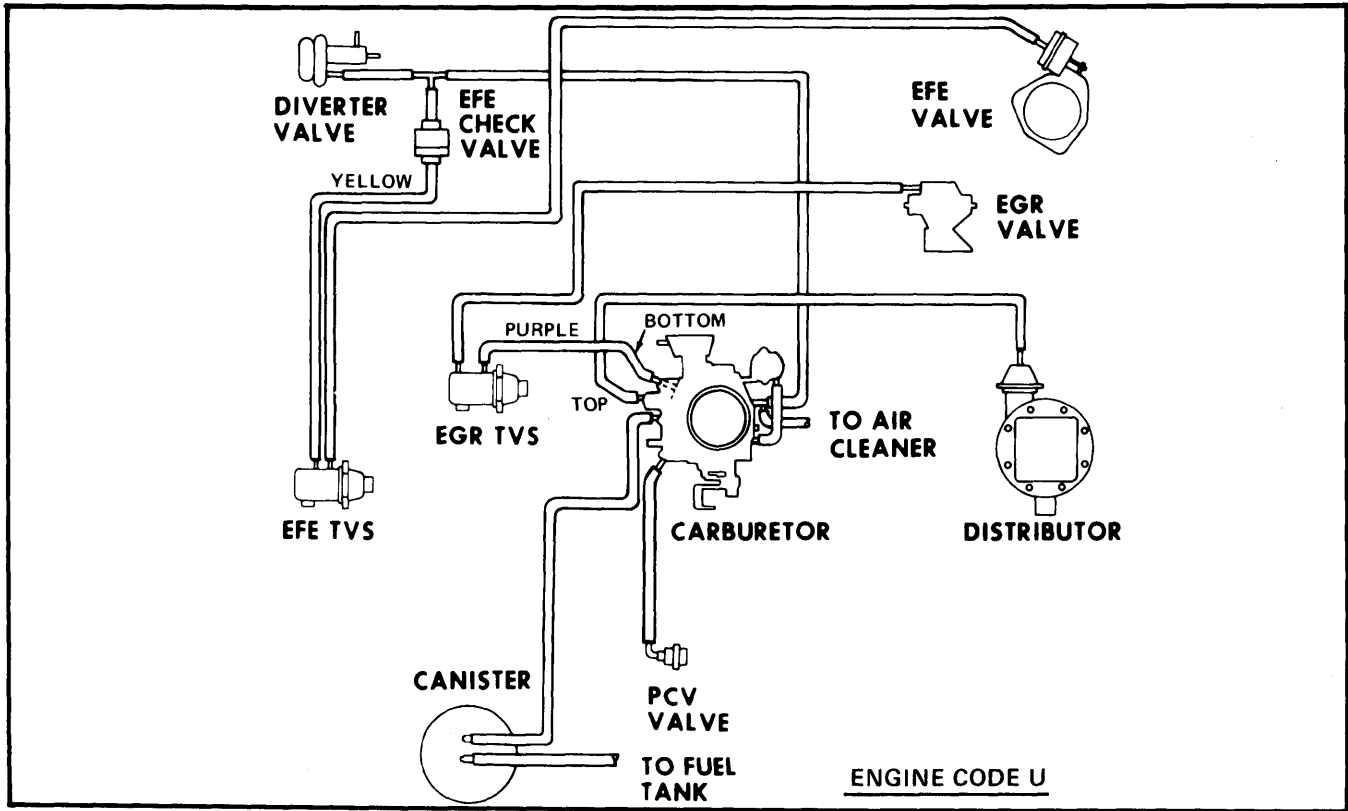

Fig. 7 305 CID Vacuum Hose Routing (High Altitude)

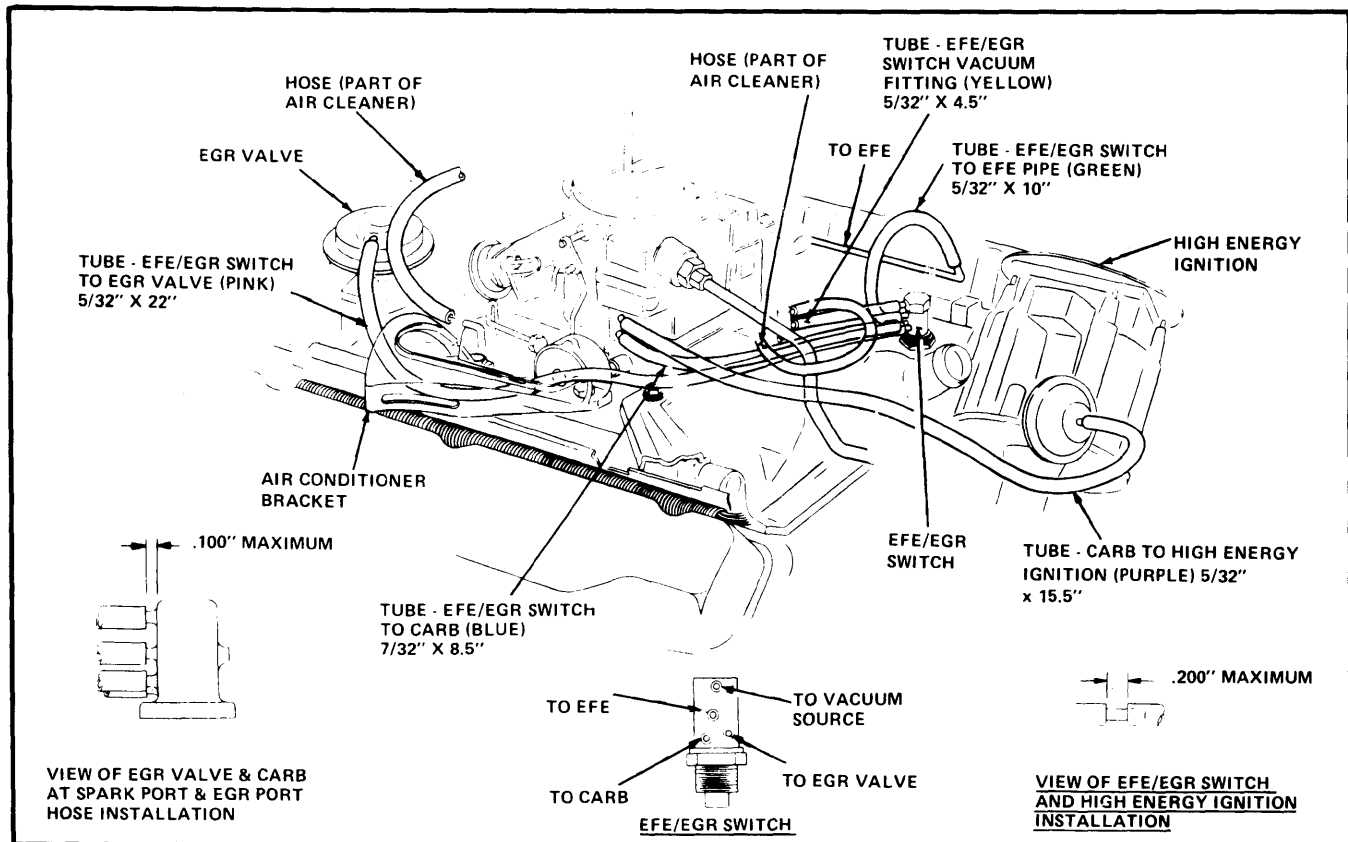

Fig. 8 350 CID Engine Code "H" Vacuum Hose Routing (Federal)

1977 EXHAUST EMISSION SYSTEMS

Buick Vacuum Diagrams (Cont.)

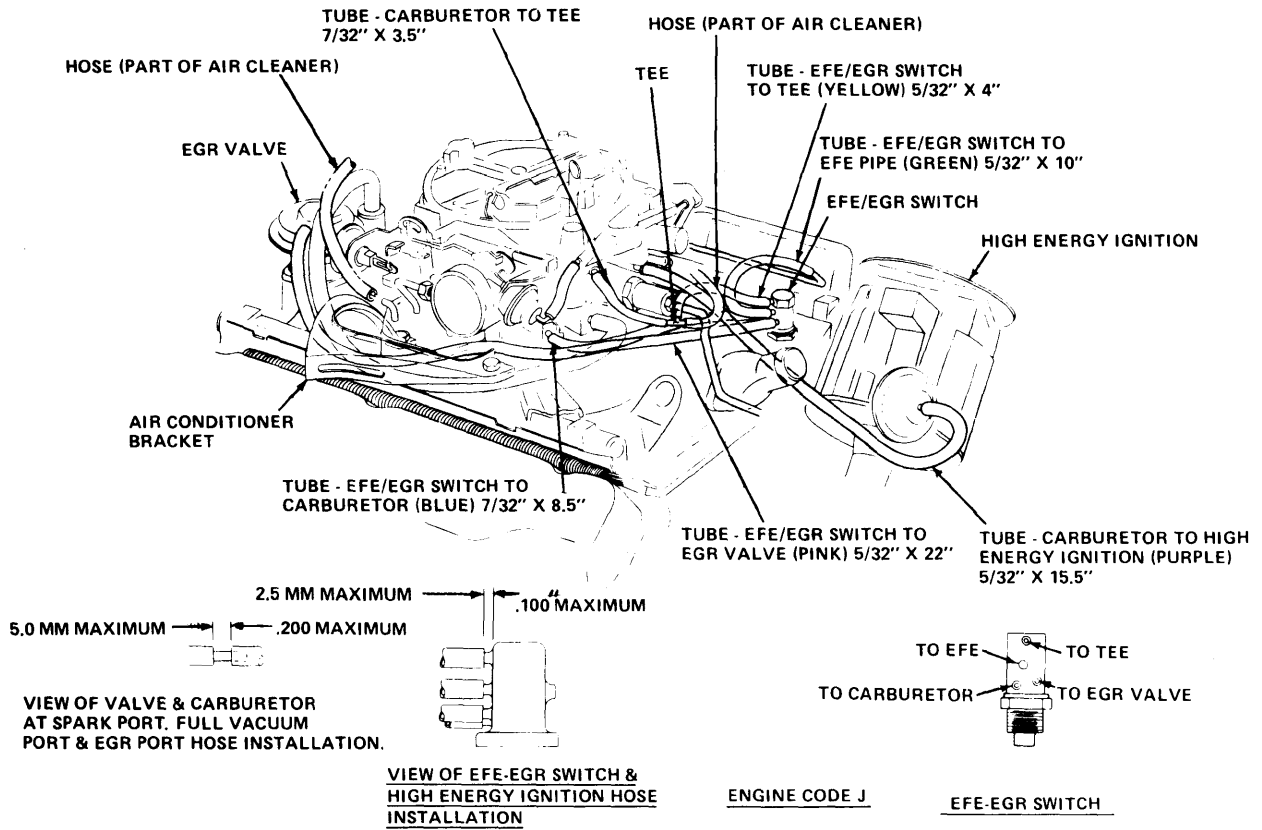

Fig. 9 350 CID Engine Code "J" Vacuum Hose Routing (Federal)

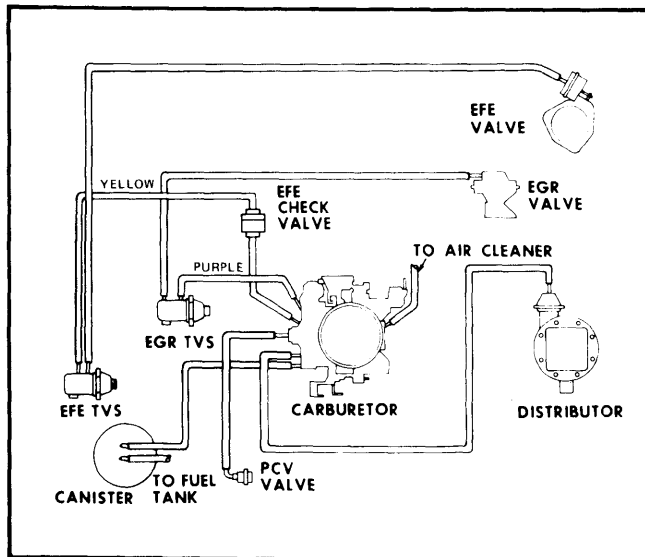

Fig. 10 350 CID Engine Code "L" Vacuum Hose Routing (Federal)

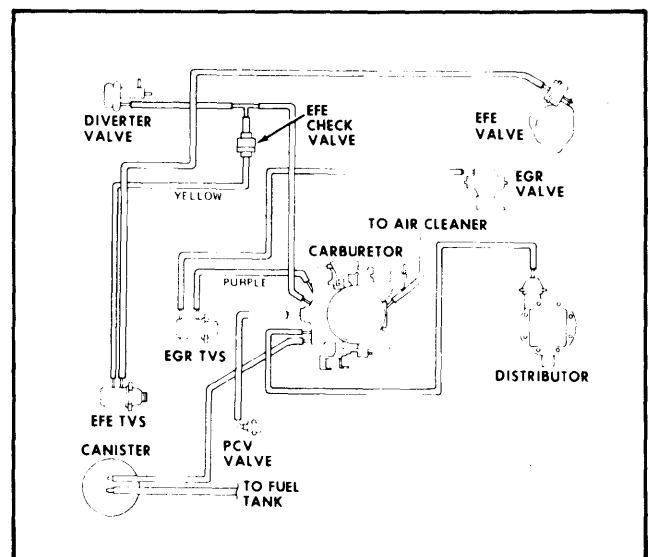

Fig. 11 350 CID Engine Code "L" Vacuum Hose Routing (High Alt. & Calif.)

1977 EXHAUST EMISSION SYSTEMS Buick Vacuum Diagrams (Cont.)

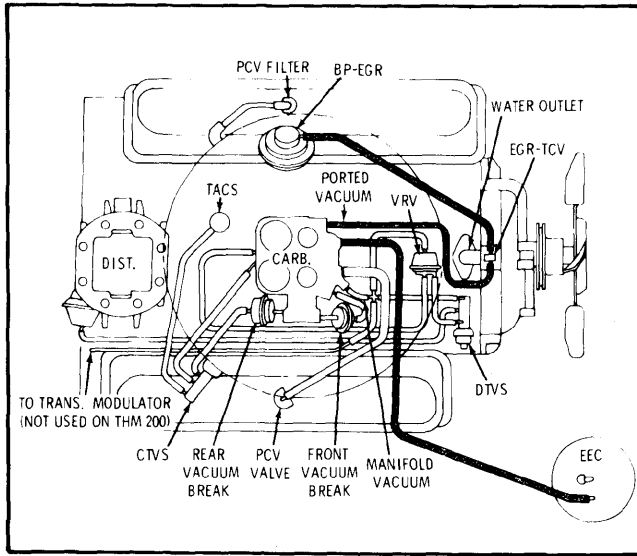

Fig. 12 350 & 403 CID Engine Code "R" Vacuum Hose Routing (Federal)

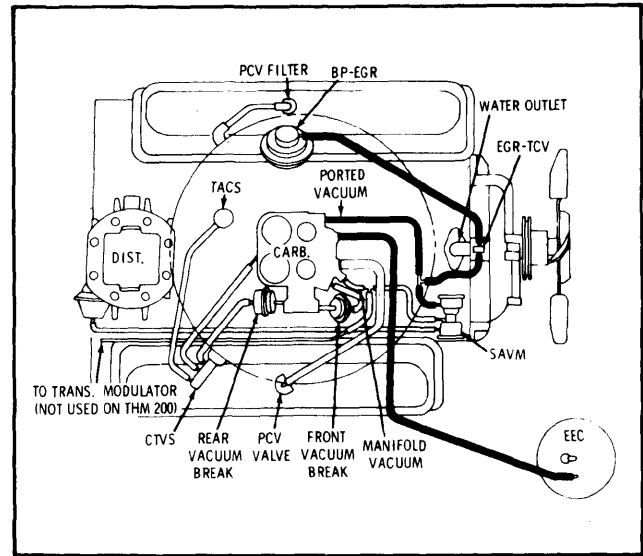

Fig. 13 403 CID Late Production Vacuum Hose Routing (Federal)

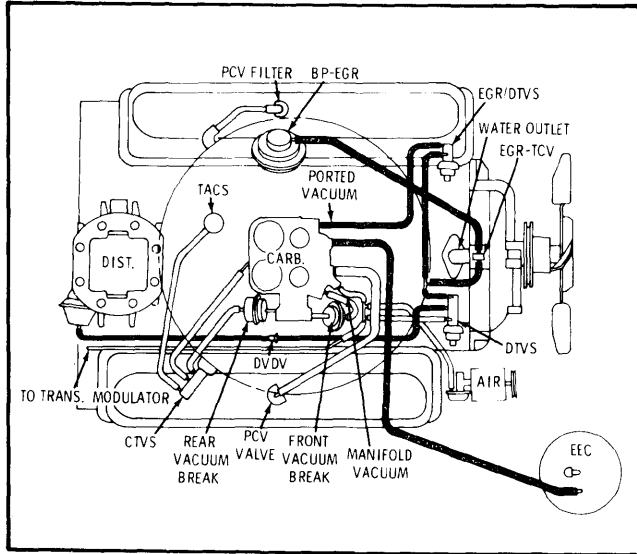

Fig. 14 350 & 403 CID Engine Code "K" & "R" Vacuum Hose Routing (California)

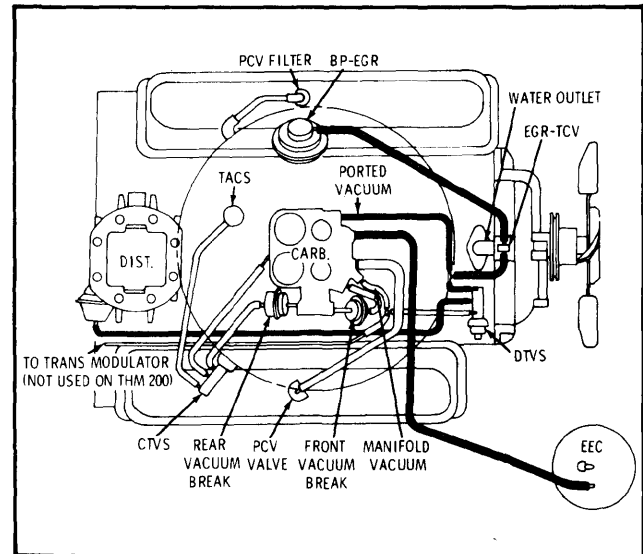

Fig. 15 305 & 403 CID Engine Code "K" & "R" Vacuum Hose Routing (High Alt.)

1977 EXHAUST EMISSION SYSTEMS Cadillac Vacuum Diagrams

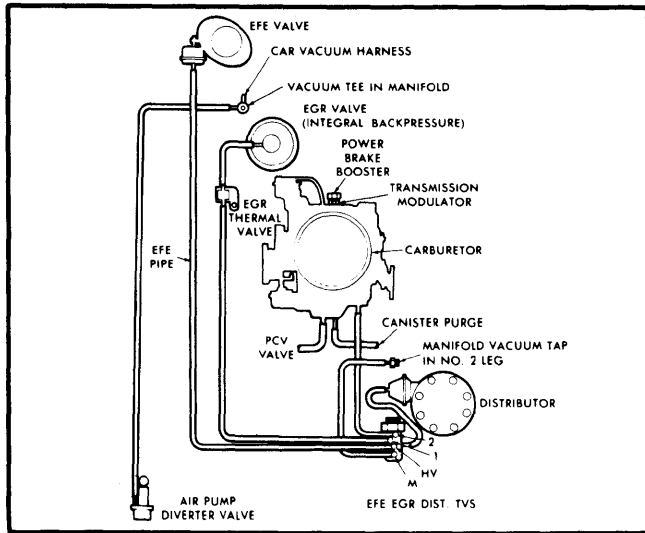

Fig. 1 425 CID without EFI Vacuum Hose Routing (Calif.)

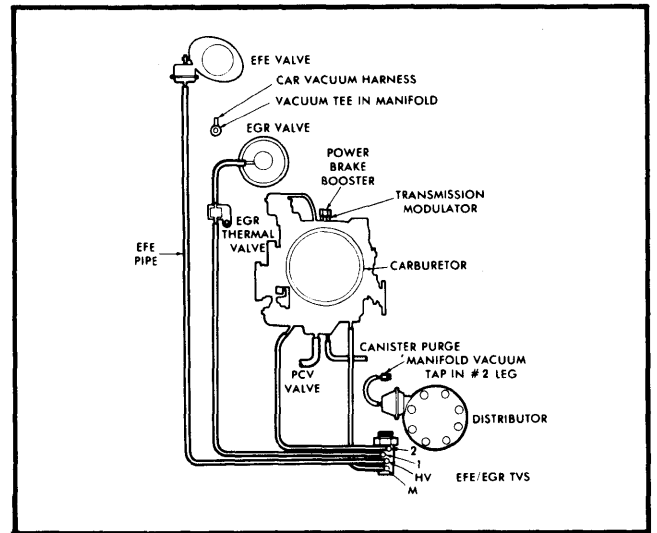

Fig. 2 425 CID without EFI Vacuum Hose Routing (Fed. & High Alt.)

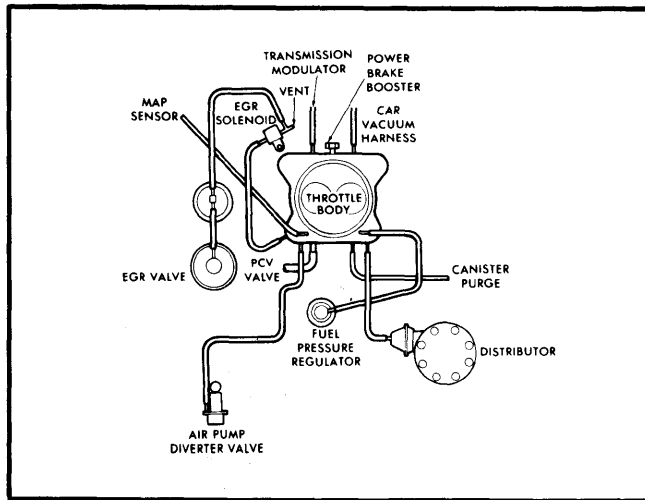

Fig. 3 350 CID with EFI Vacuum Hose Routing (Calif.)

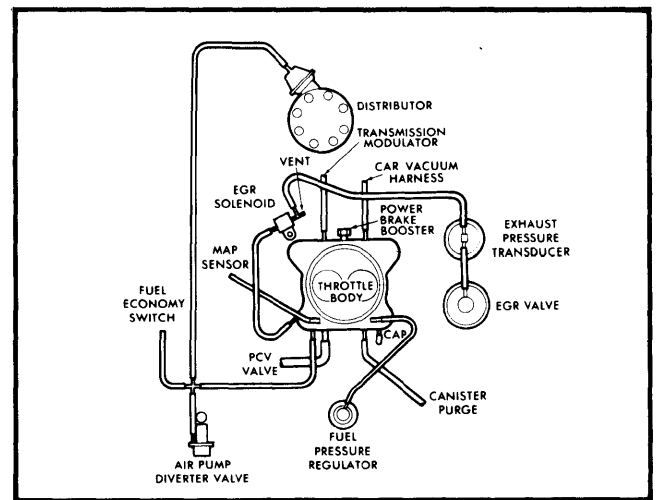

Fig. 4 350 CID with EFI Vacuum Hose Routing (Fed. & High Alt.)

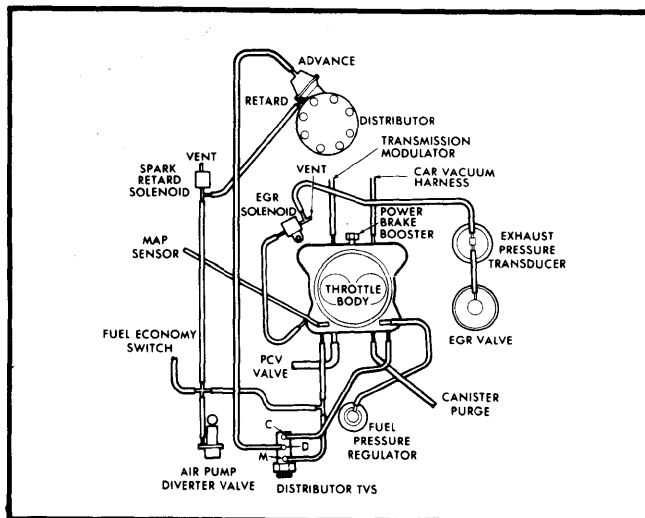

Fig. 5 425 CID with EFI Vacuum Hose Routing (Calif.)

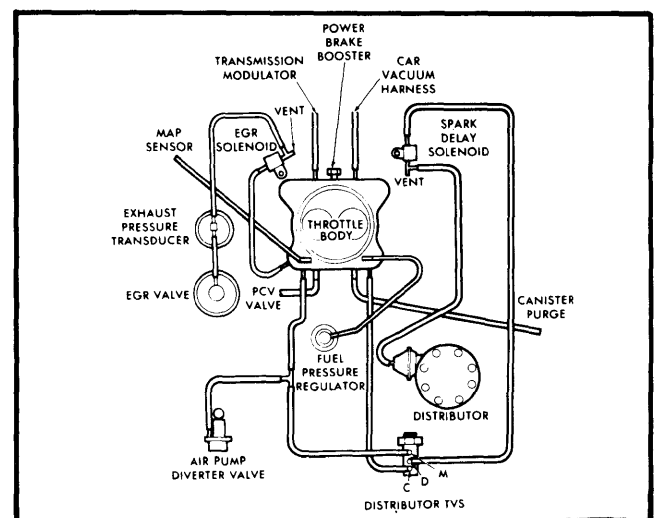

Fig. 6 425 CID with EFI Vacuum Hose Routing (Fed. & High Alt.)

1977 EXHAUST EMISSION SYSTEMS Chevrolet Vacuum Diagrams

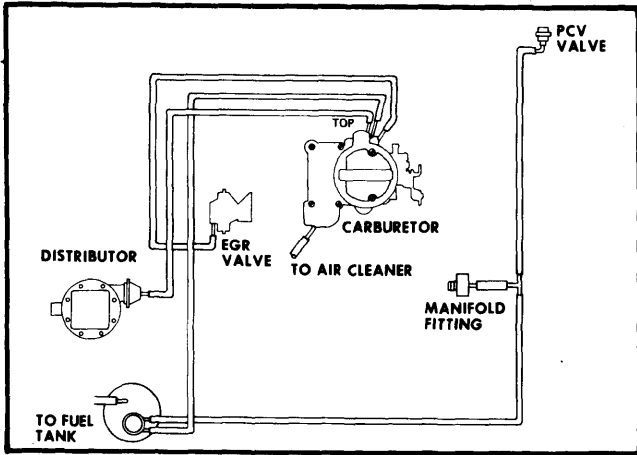

Fig. 1 Chevette Vacuum Hose Routing (Federal)

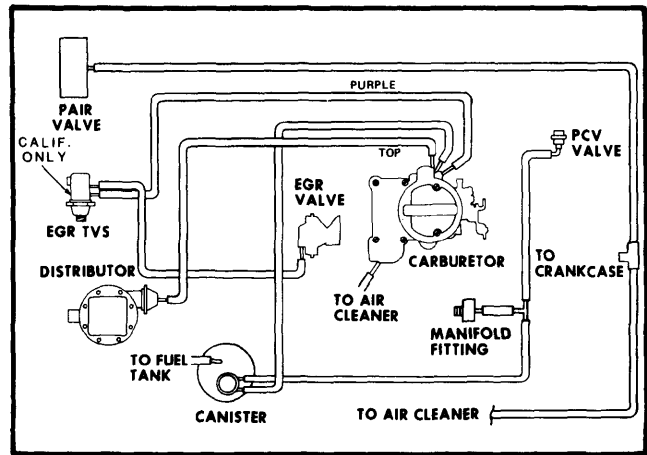

Fig. 2 Chevette Vacuum Hose Routing (High Alt. & Calif.)

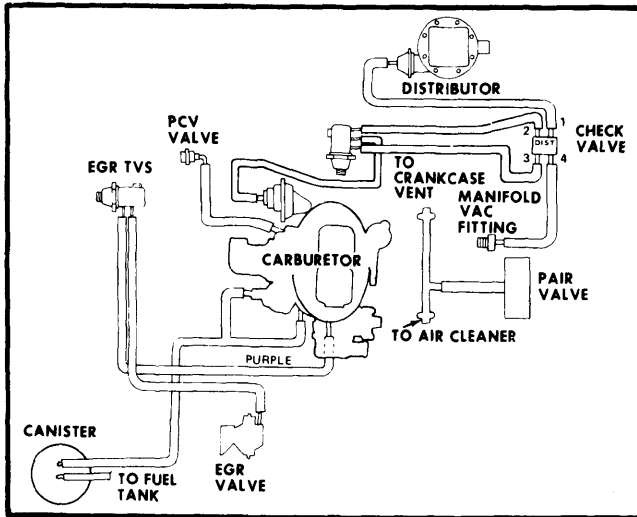

Fig. 3 Vega & Monza 140 CID Vacuum Hose Routing (Federal)

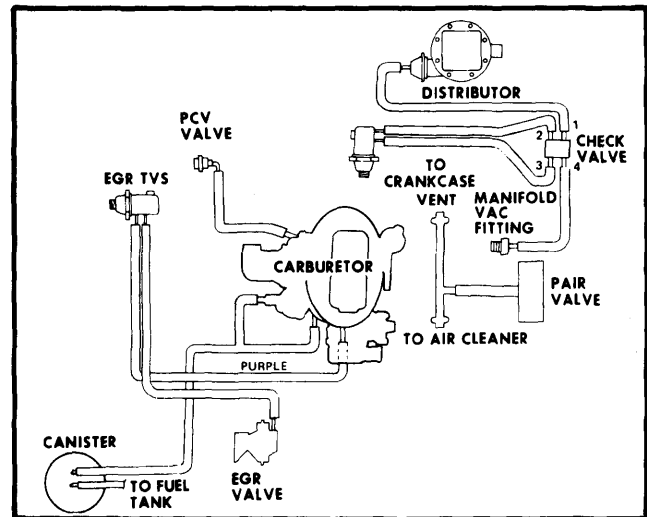

Fig. 4 Vega & Monza 140 CID Vacuum Hose Routing (High Alt. & Calif.)

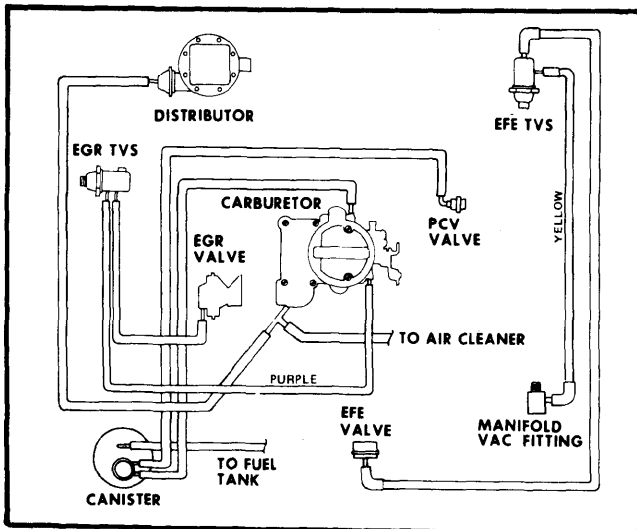

Fig. 5 All Models 250 CID Vacuum Hose Routing (Fed. & High Alt.)

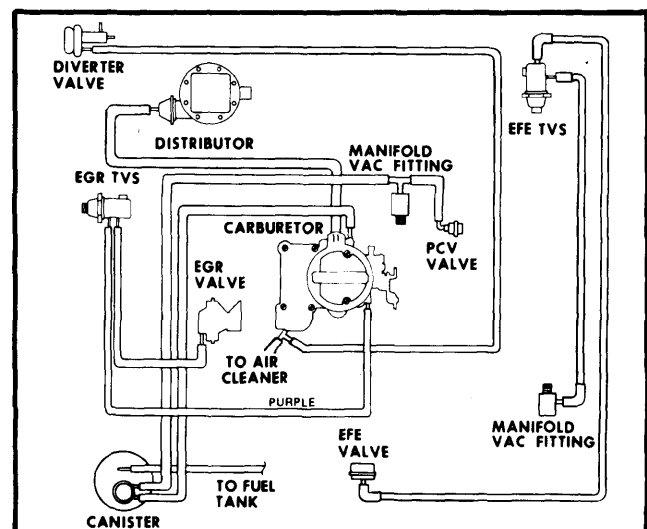

Fig. 6 All Models 250 CID Vacuum Hose Routing (Calif.)

1977 EXHAUST EMISSION SYSTEMS Chevrolet Vacuum Diagrams (Cont.)

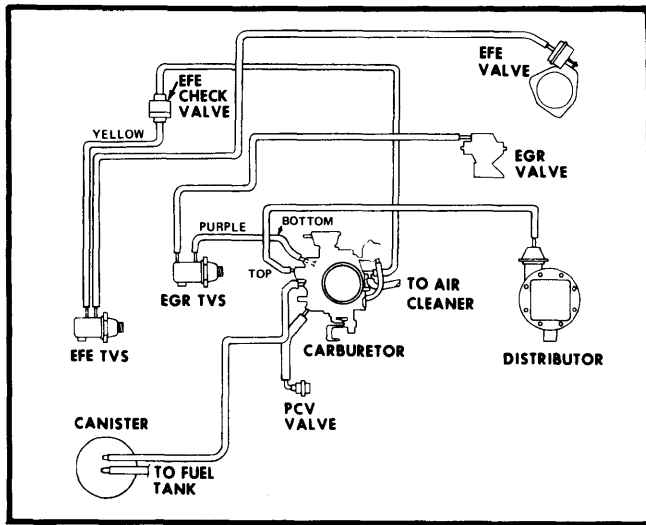

Fig. 7 All Models 305 CID Vacuum Hose Routing (Federal)

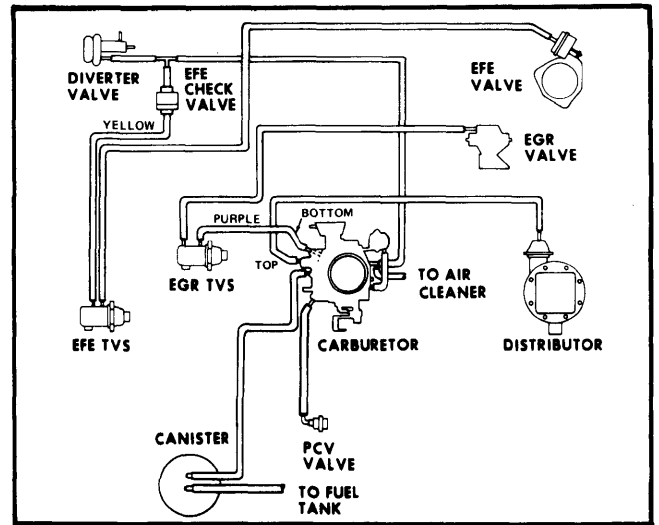

Fig. 8 All Models 305 CID Vacuum Hose Routing (High Alt.)

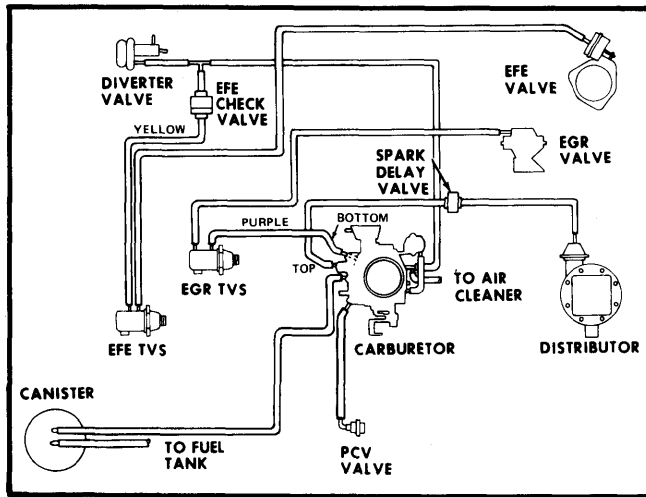

Fig. 9 All Models 305 CID Vacuum Hose Routing (Calif.)

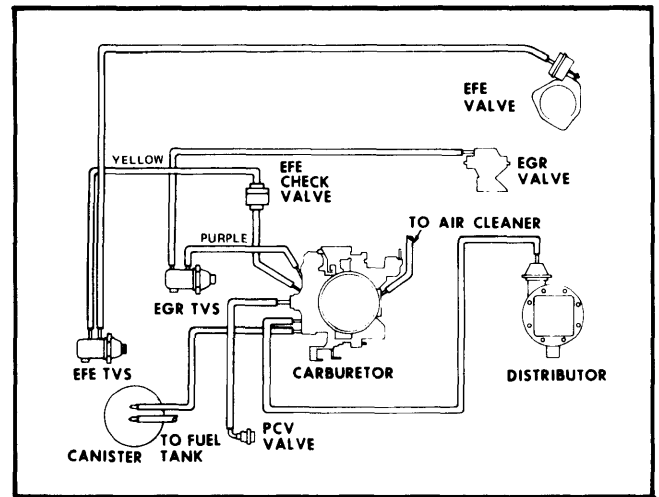

Fig. 10 All Models 350 CID Vacuum Hose Routing (Federal)

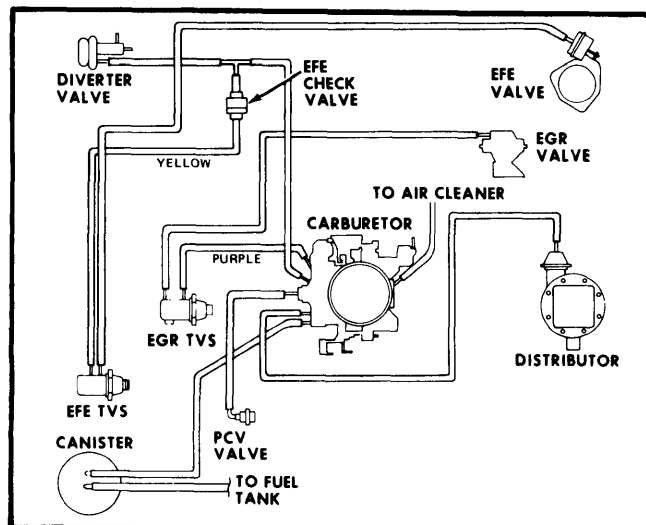

Fig. 11 All Models 350 CID Vacuum Hose Routing
(High Alt. & Calif.)

1977 EXHAUST EMISSION SYSTEMS Oldsmobile Vacuum Diagrams

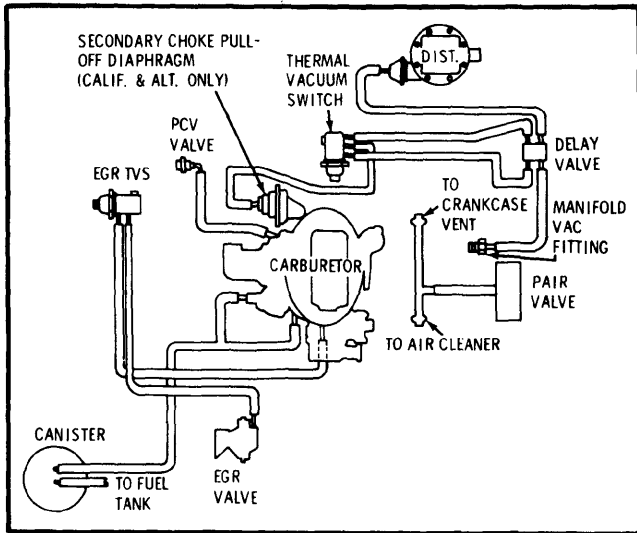

Fig. 1 140 CID Vacuum Hose Routing (All)

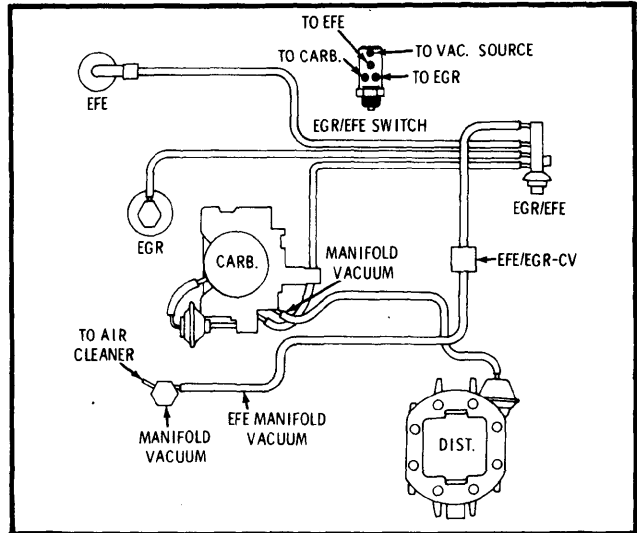

Fig. 2 231 CID Vacuum Hose Routing (Federal)

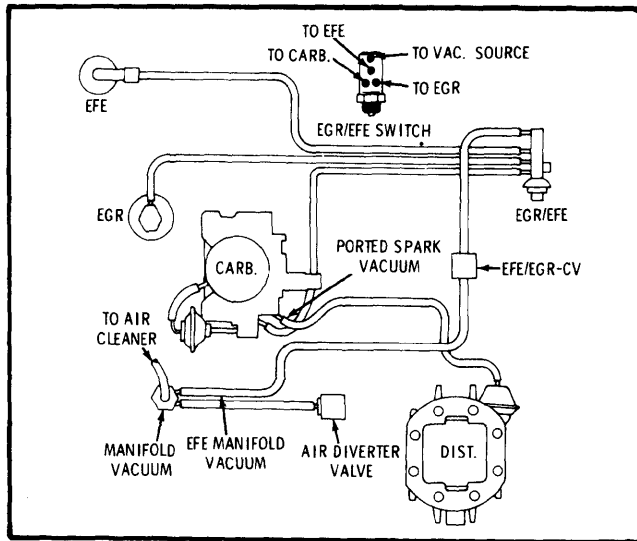

Fig. 3 231 CID Vacuum Hose Routing (High Alt. & Calif.)

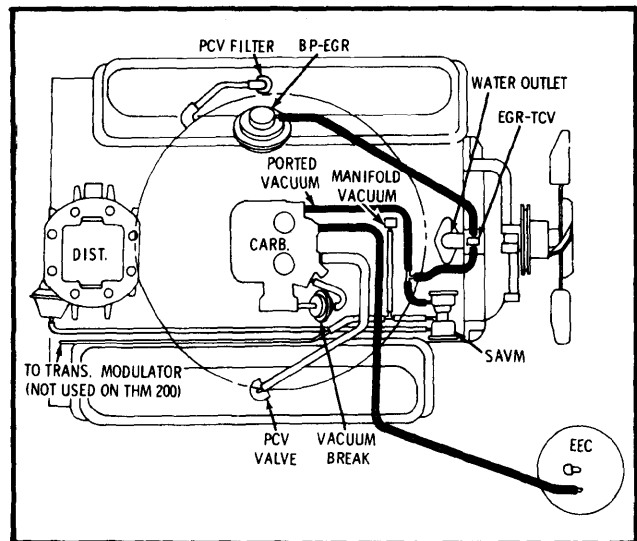

Fig. 4 260 CID Vacuum Hose Routing (Federal)

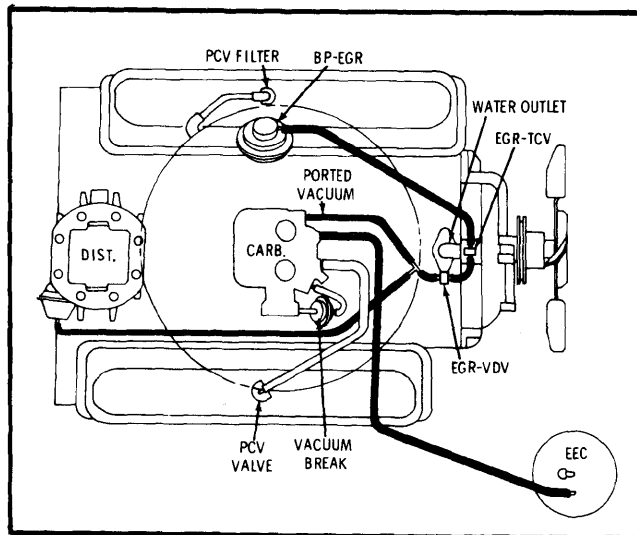

Fig. 5 260 CID w/5-Speed Man. Trans. Vacuum Hose Routing (Federal)

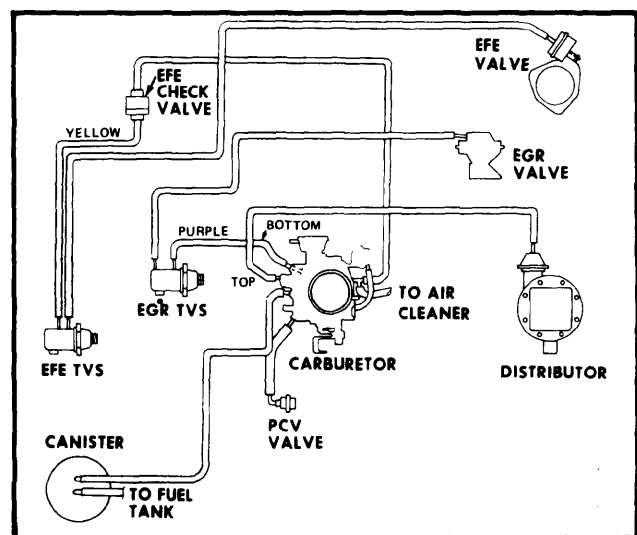

Fig. 6 Starfire 305 CID Vacuum Hose Routing (Federal)

1977 EXHAUST EMISSION SYSTEMS Oldsmobile Vacuum Diagrams (Cont.)

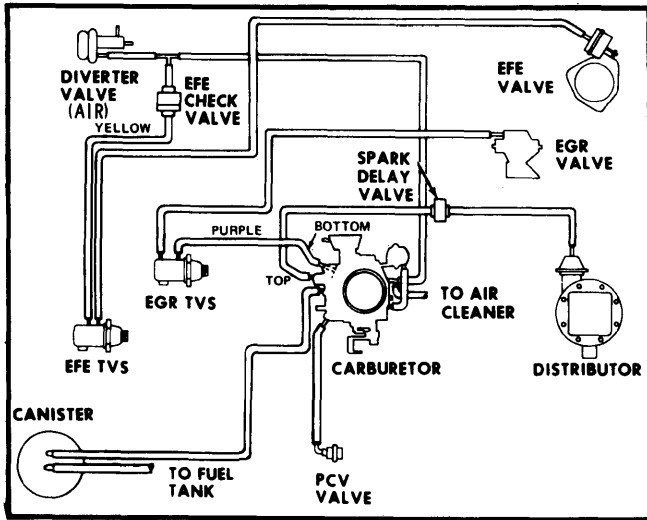

Fig. 7 Starfire 305 CID Vacuum Hose Routing (High Alt. & Calif.)

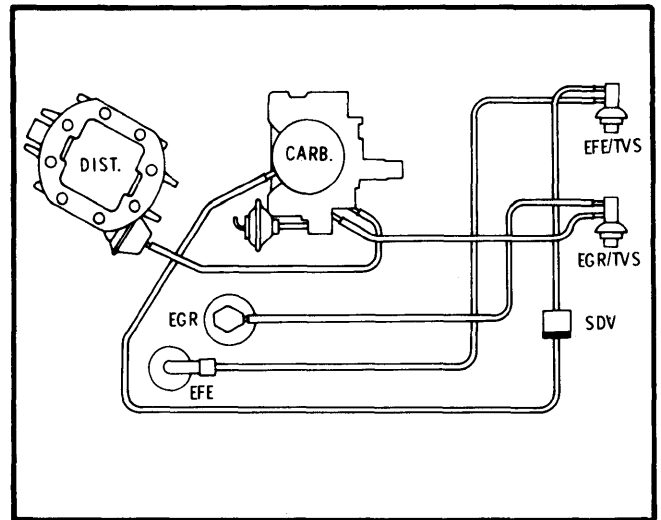

Fig. 8 Omega 305 CID Vacuum Hose Routing (Federal)

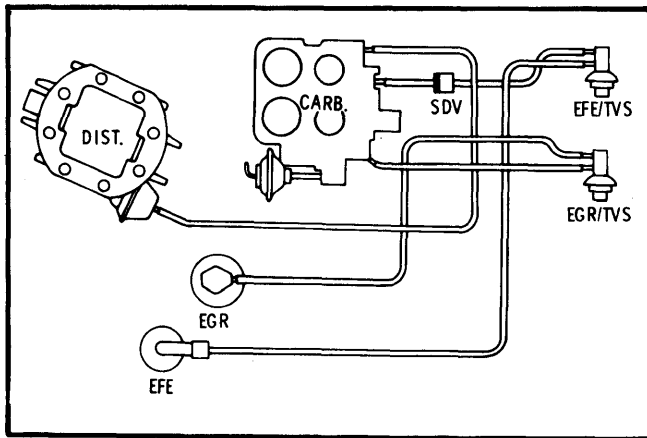

Fig. 9 Omega 350 CID VIN "L" Vac. Hose Routing (Federal)

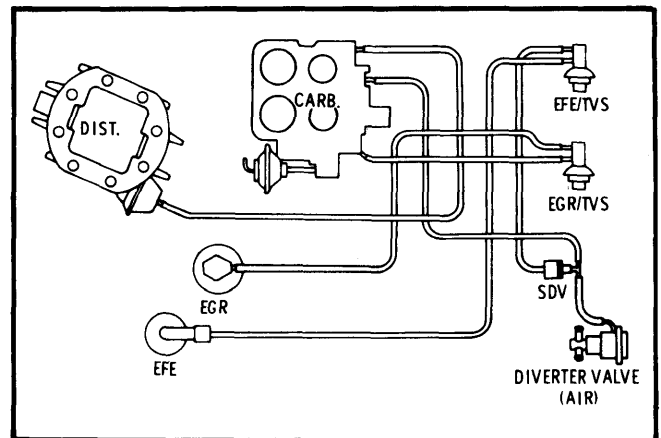

Fig. 10 Omega 350 CID VIN "L" Vac. Hose Routing (High Altitude & California)

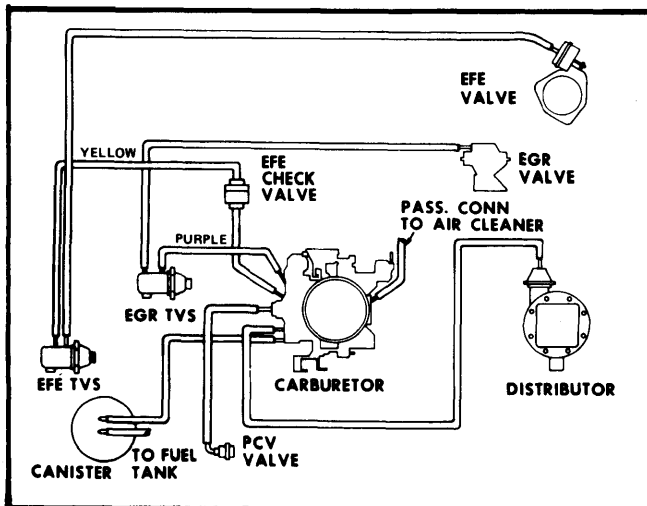

Fig. 11 88 350 CID VIN "L" Vac. Hose Routing (Federal)

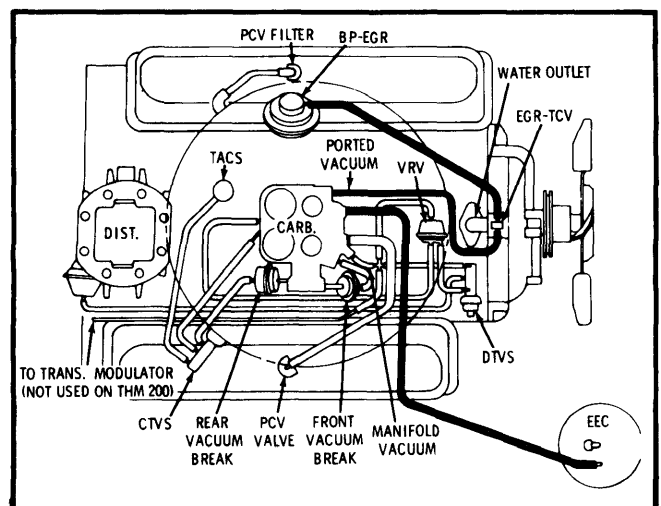

Fig. 12 350 CID VIN "R" Vacuum Hose Routing (Federal)

1977 EXHAUST EMISSION SYSTEMS Oldsmobile Vacuum Diagrams (Cont.)

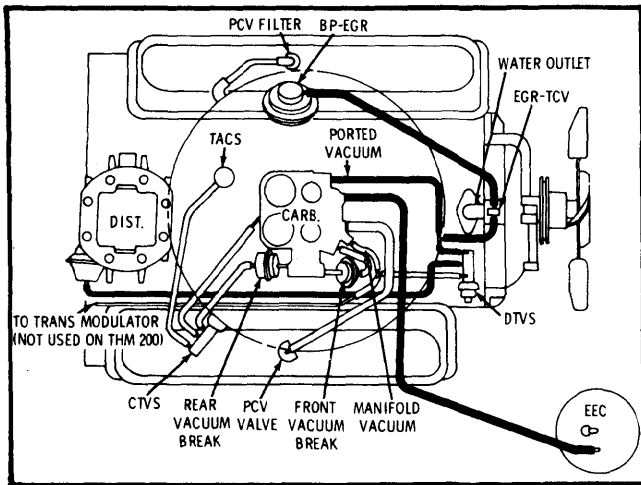

Fig. 13 350 & 403 CID VIN "R" Vacuum Hose Routing (High Altitude)

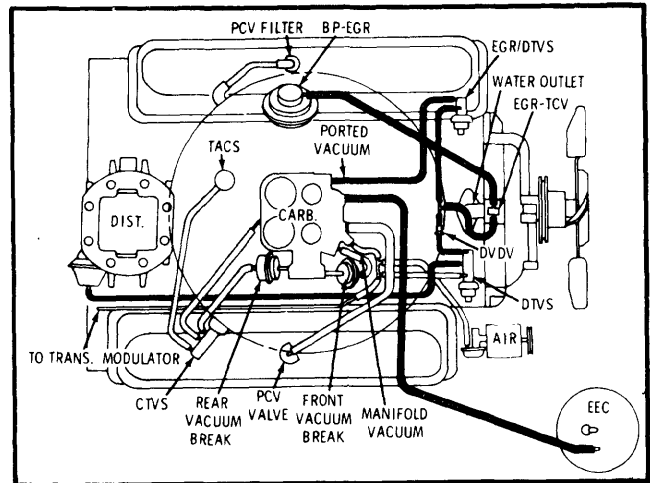

Fig. 14 350 CID VIN "R" & 403 CID Vac. Hose Routing (Calif.)

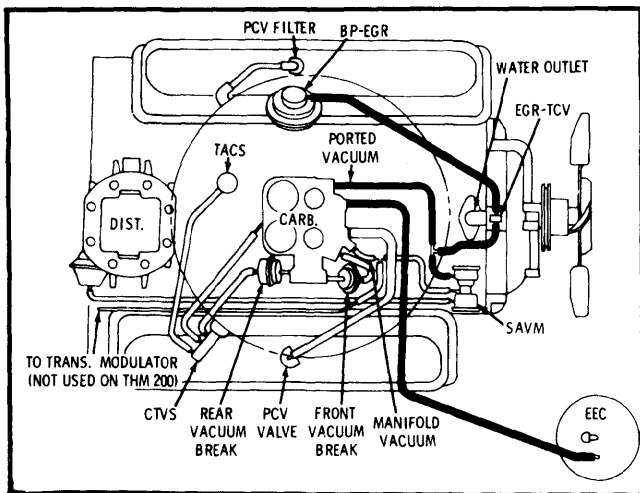

Fig. 15 403 CID Vacuum Hose Routing (Federal)

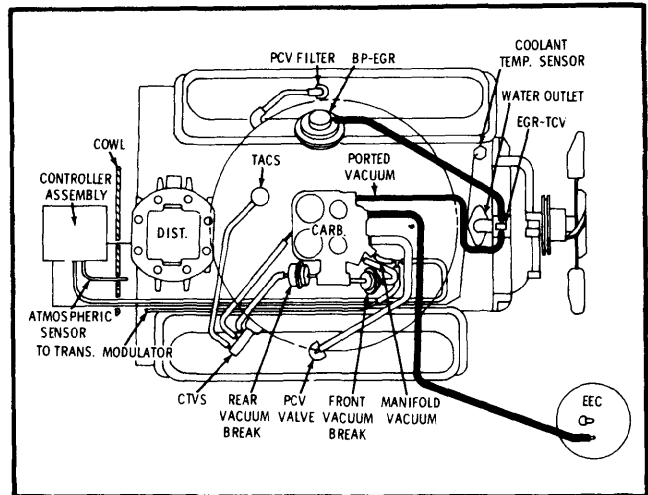

Fig. 16 Toronado 403 CID Vacuum Hose Routing (Federal)

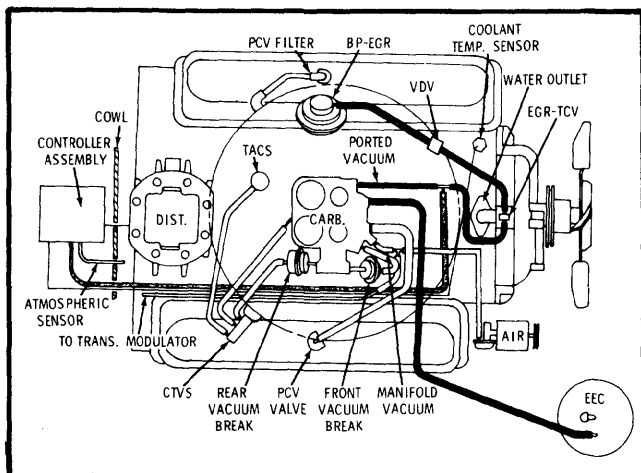

Fig. 17 Toronado 403 CID Vacuum Hose Routing (Calif.)

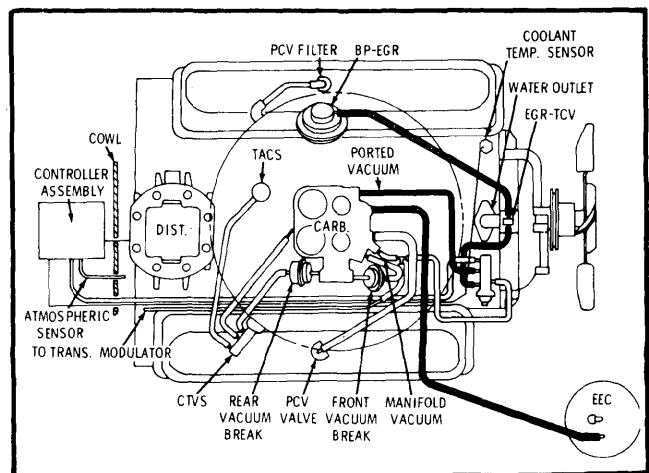

Fig. 18 Toronado 403 CID Vacuum Hose Routing (High Alt.)

1977 EXHAUST EMISSION SYSTEMS Pontiac Vacuum Diagrams

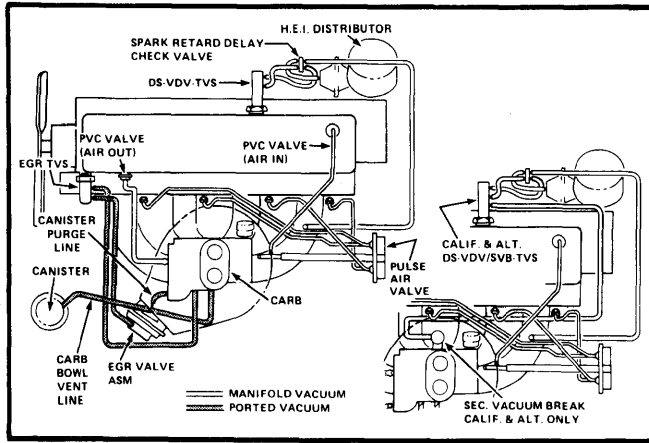

Fig. 1 140 CID Vacuum Hose Routing (All States)

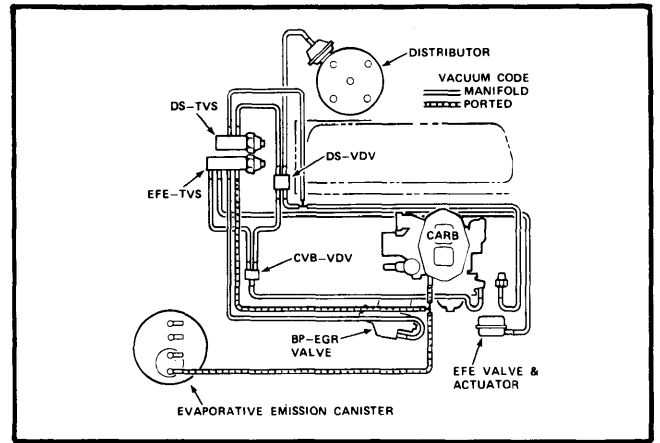

Fig. 2 151 CID Vacuum Hose Routing (Calif. with Auto. Trans., non-A/C)

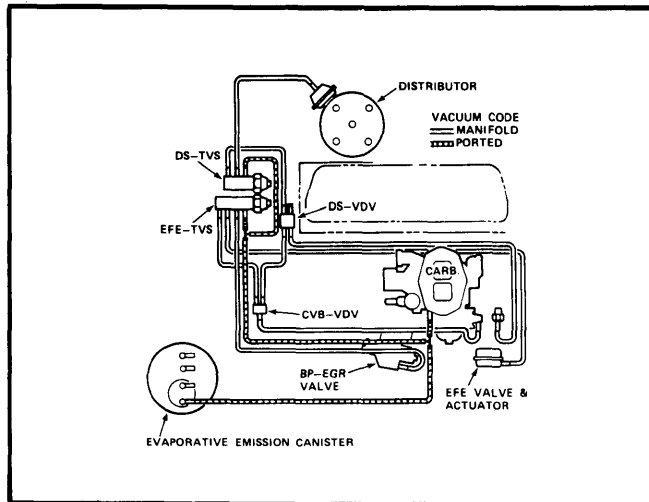

Fig. 3 151 CID Vacuum Hose Routing (Calif. with Auto. Trans. & A/C)

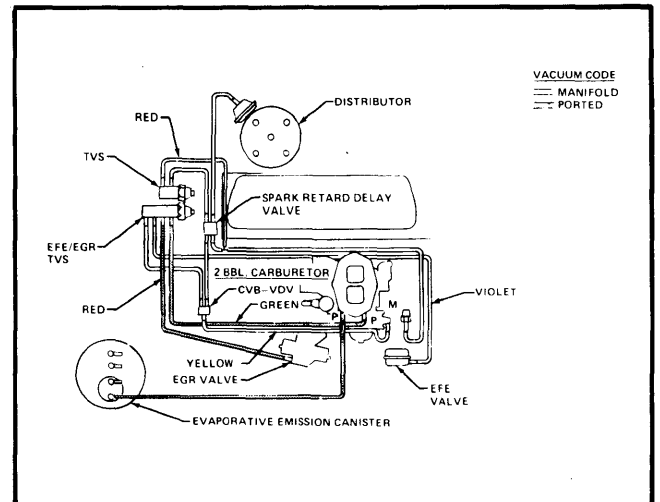

Fig. 4 151 CID Vacuum Hose Routing (Federal with Man. Trans. & Auto. Trans., non-A/C)

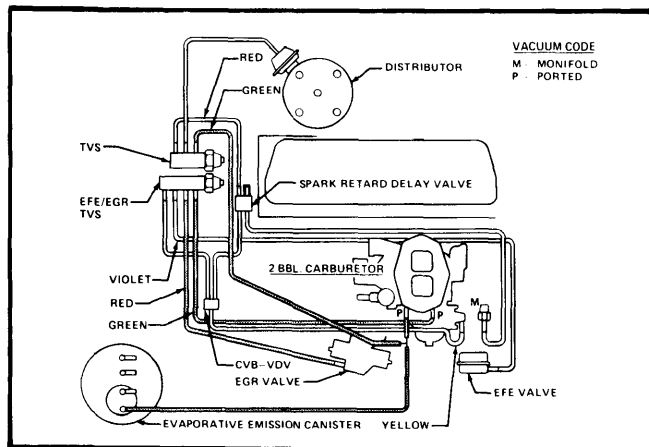

Fig. 5 151 CID Vacuum Hose Routing (Federal with Auto. Trans. & A/C)

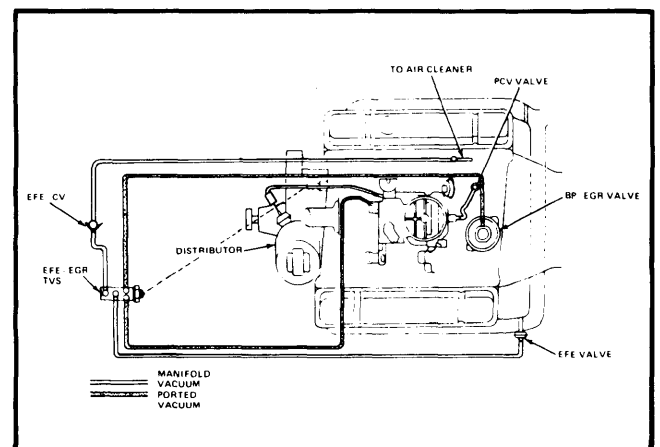

Fig. 6 231 CID Vacuum Hose Routing (Federal)

1977 EXHAUST EMISSION SYSTEMS Pontiac Vacuum Diagrams (Cont.)

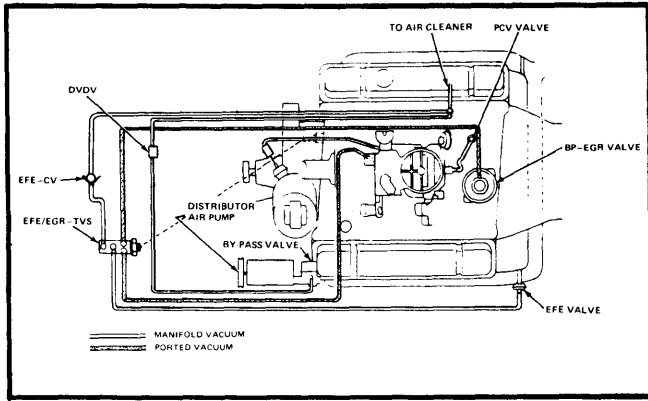

Fig. 7 231 CID Vacuum Hose Routing (High Alt.)

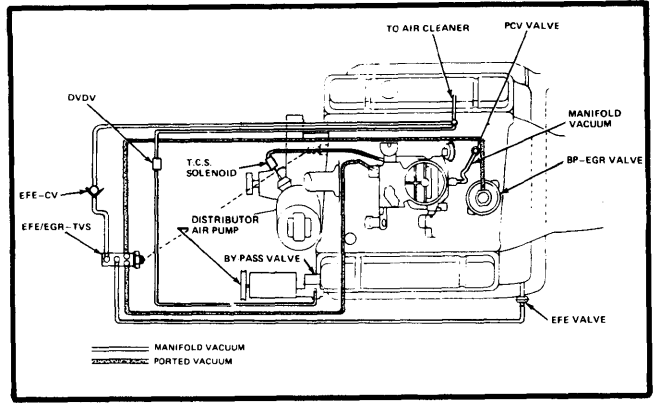

Fig. 8 231 CID Vacuum Hose Routing (Calif. w/Man. Trans.)

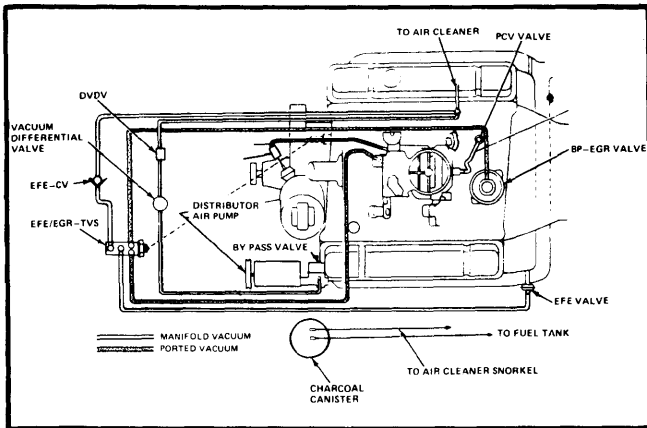

Fig. 9 231 CID Vacuum Hose Routing (Calif. w/Auto. Trans.)

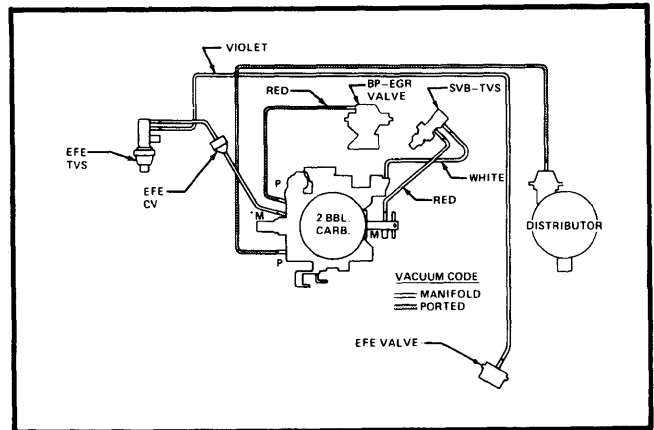

Fig. 10 301 CID Vacuum Hose Routing (Federal w/Man. Trans.)

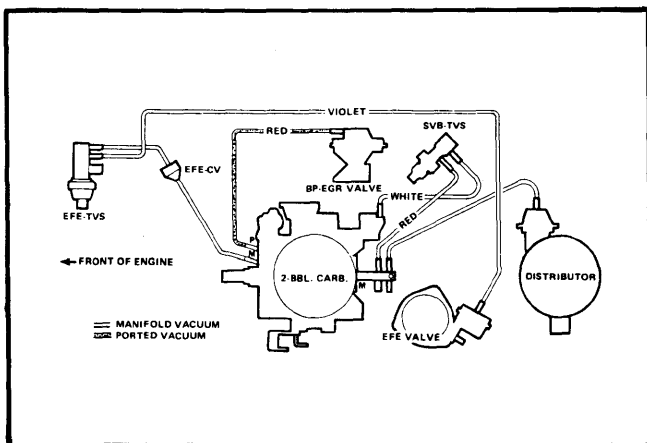

Fig. 11 301 CID Vacuum Hose Routing (Federal Auto. Trans. without A/C)

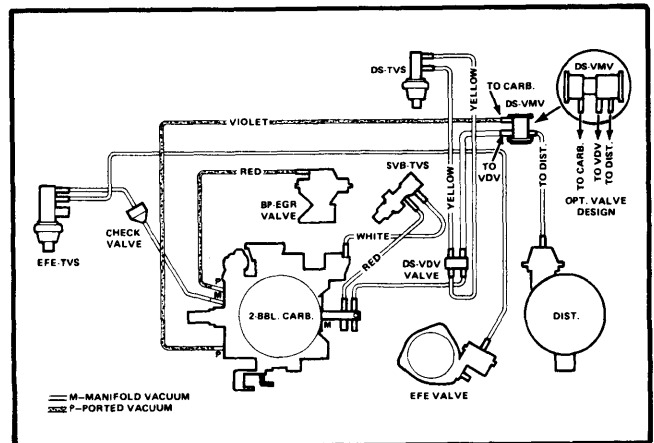

Fig. 12 301 CID Vacuum Hose Routing (Federal Auto. Trans. with A/C)

1977 EXHAUST EMISSION SYSTEMS Pontiac Vacuum Diagrams (Cont.)

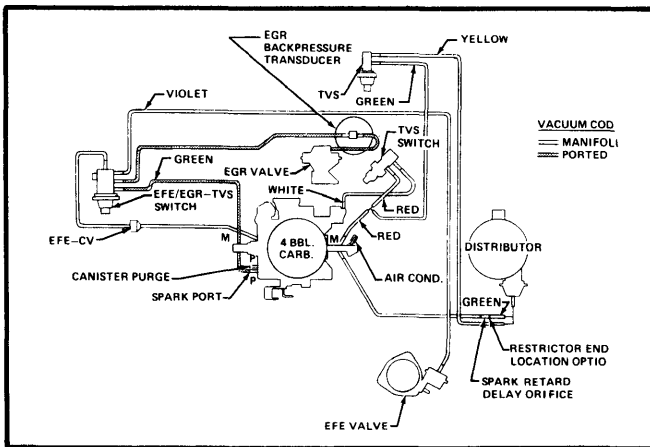

Fig. 13 350 & 400 CID VIN "P" & "Z" Vac. Hose Routing (Federal with Auto. Trans.)

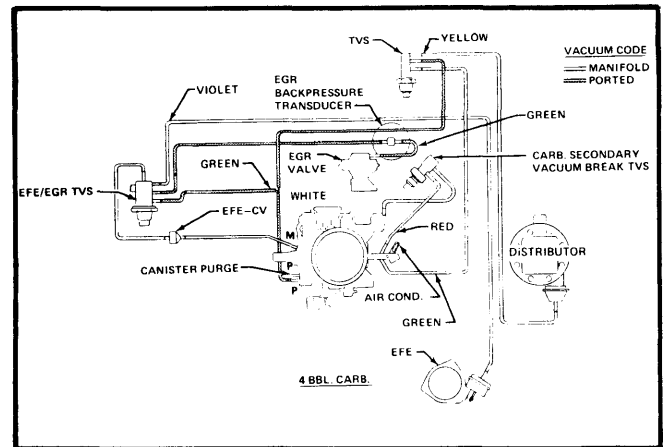

Fig. 14 400 CID Vacuum Hose Routing (Federal w/Man Trans.)

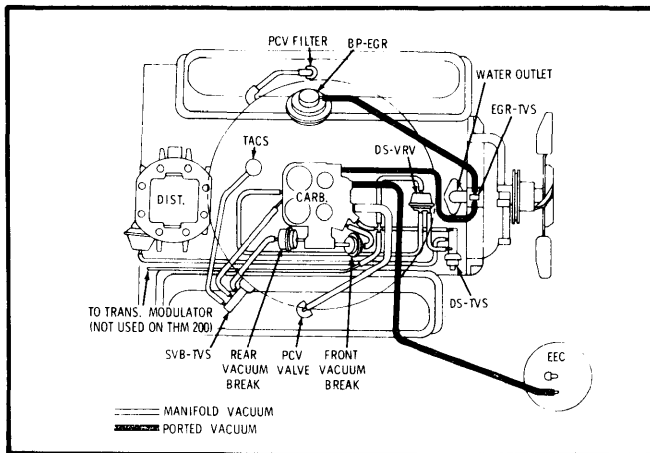

Fig. 15 350 & 403 CID VIN "R" & "K" Vac. Hose Routing (Federal)

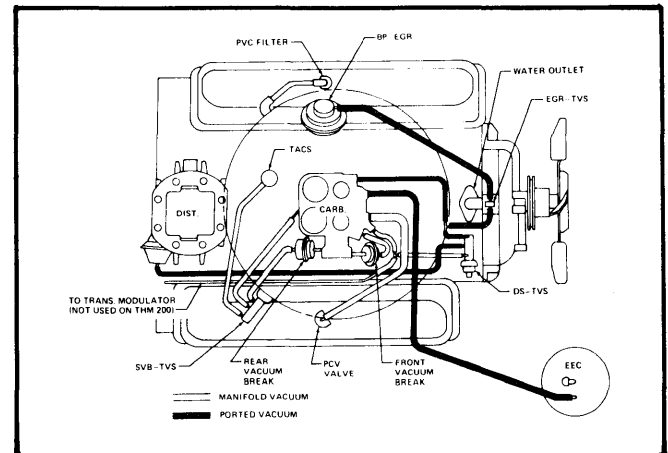

Fig. 16 350 & 403 CID VIN "R" & "K" Vac. Hose Routing (High Altitude)

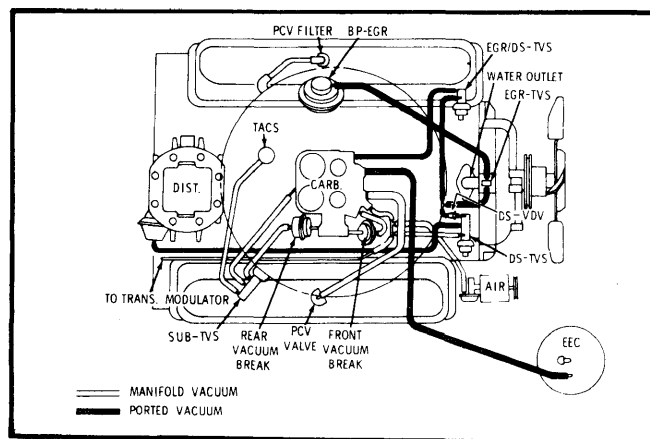

Fig. 17 350 & 403 CID VIN "R" & "K" Vac. Hose Routing (Calif.)