

1975 EXHAUST EMISSIONS SYSTEMS Buick Vacuum Diagrams

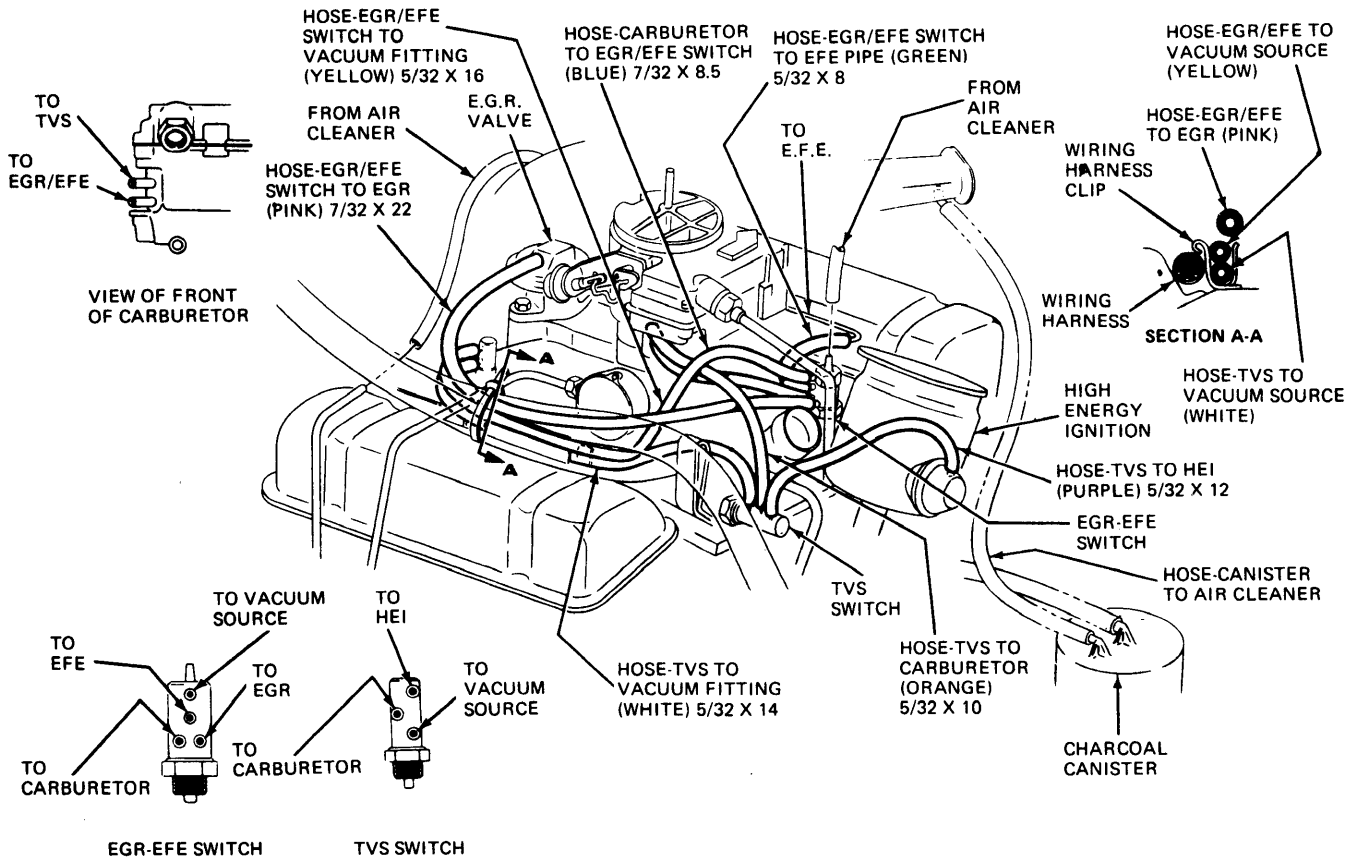

VACUUM HOSE ROUTING, 231" V6 (FEDERAL)

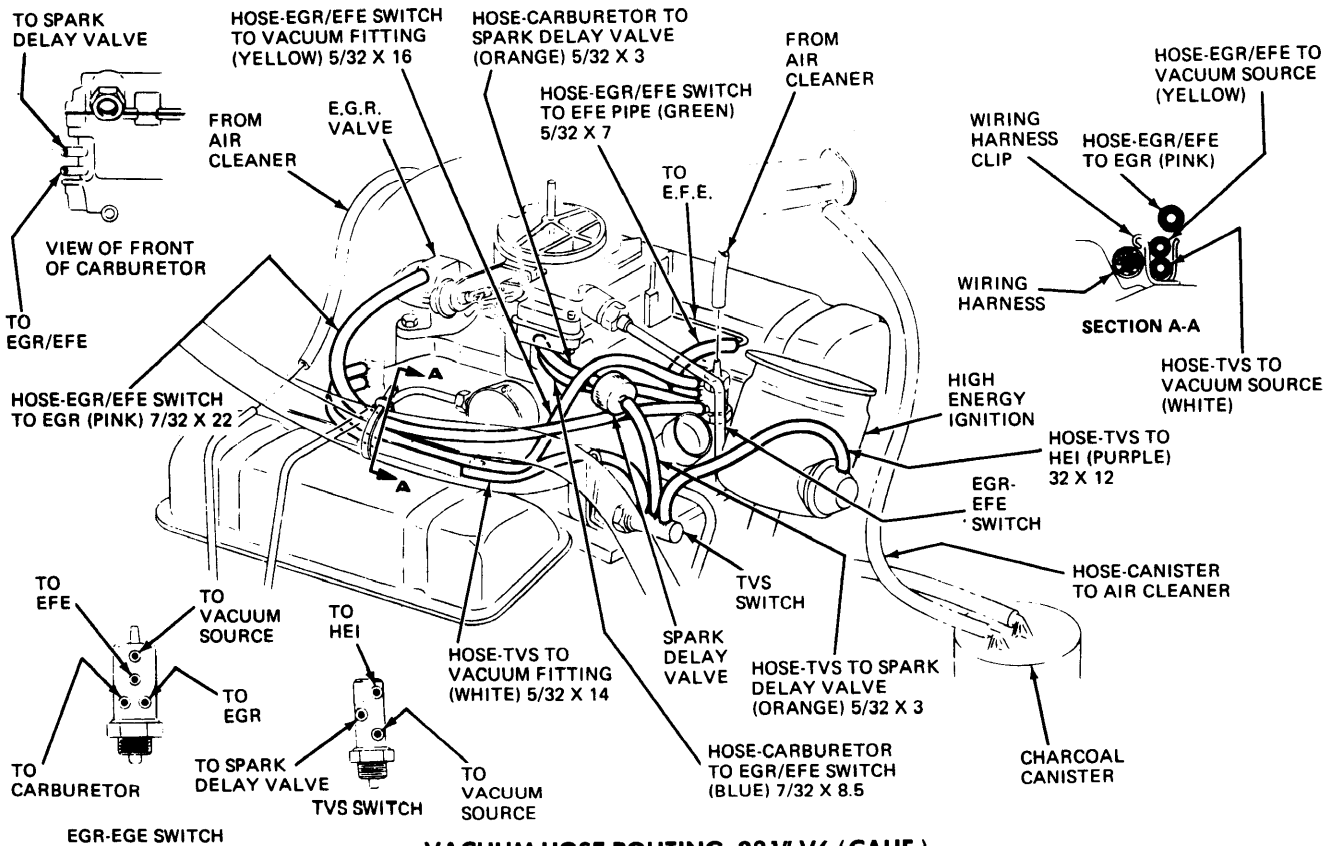

VACUUM HOSE ROUTING, 231" V6 (CALIF.)

1975 EXHAUST EMISSIONS SYSTEMS

Buick Vacuum Diagrams (Cont.)

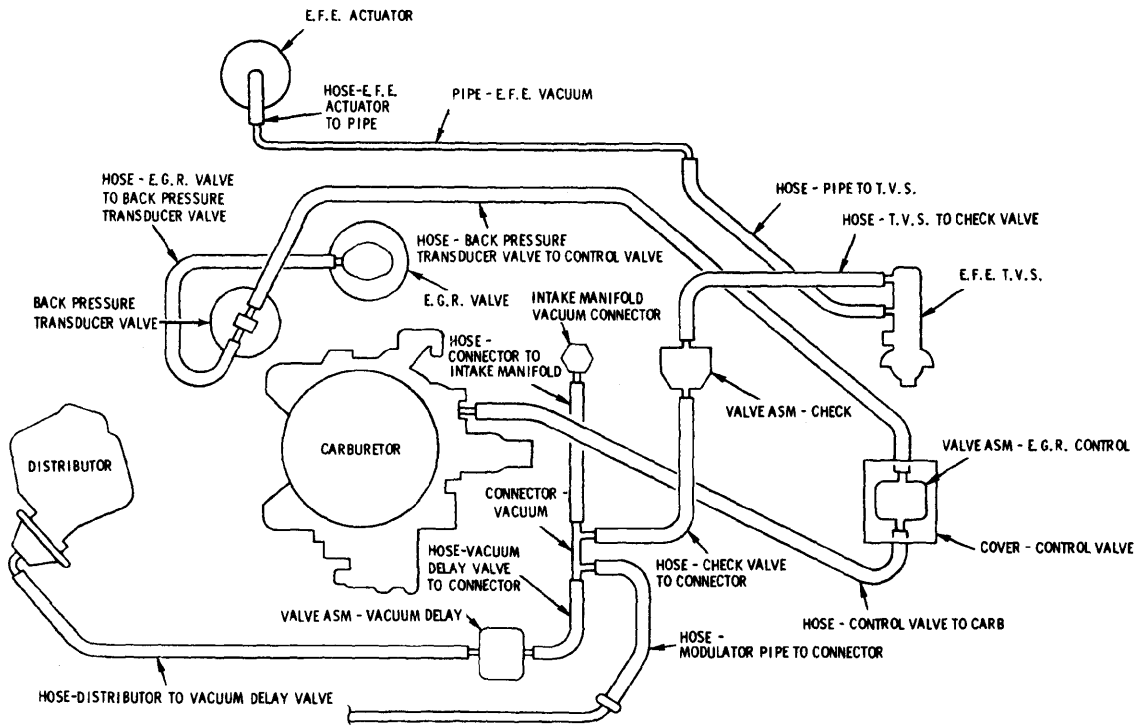

VACUUM HOSE ROUTING, 260" V8 (FEDERAL)

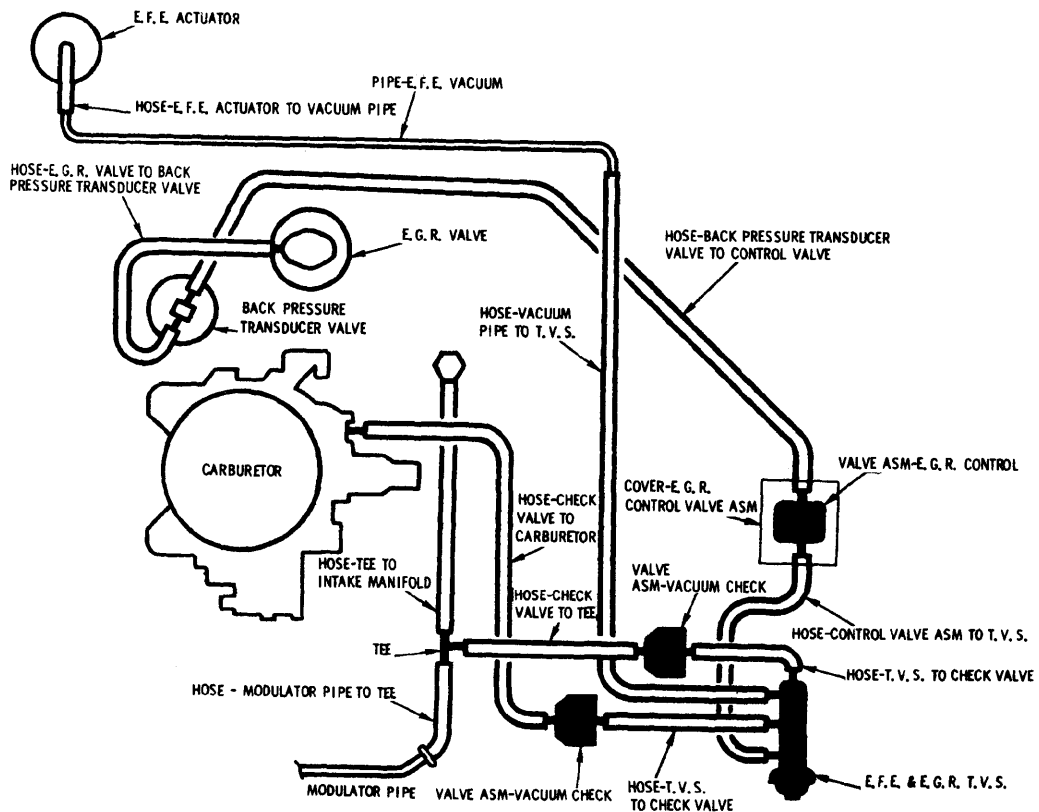

VACUUM HOSE ROUTING, 260" V8 (CALIF.)

1975 EXHAUST EMISSIONS SYSTEMS Buick Vacuum Diagrams (Cont.)

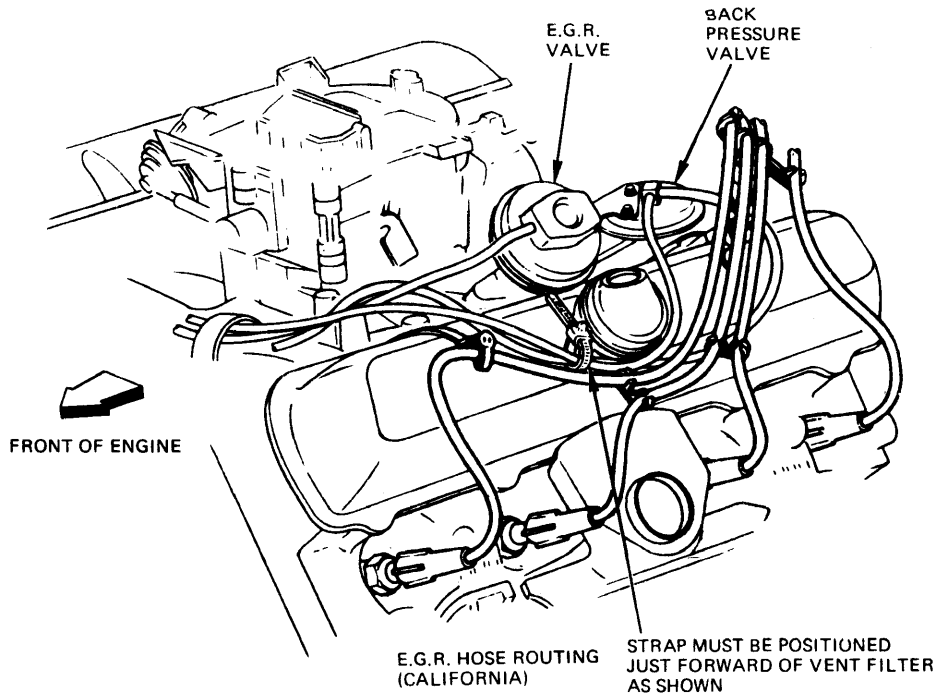

EGR VALVE STRAP, 260" V8

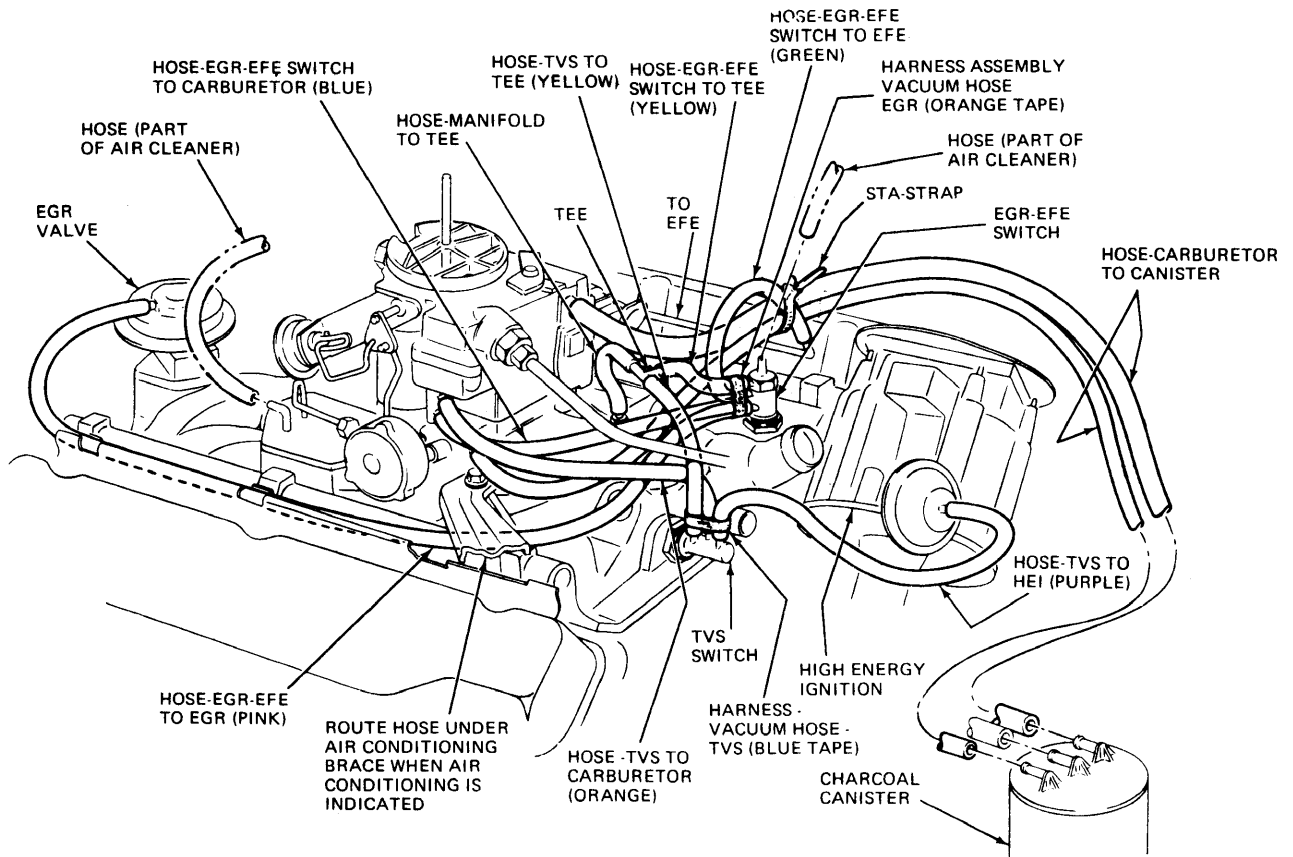

VACUUM HOSE ROUTING, 350" V8 (2-Bl.)

1975 EXHAUST EMISSIONS SYSTEMS Buick Vacuum Diagrams (Cont.)

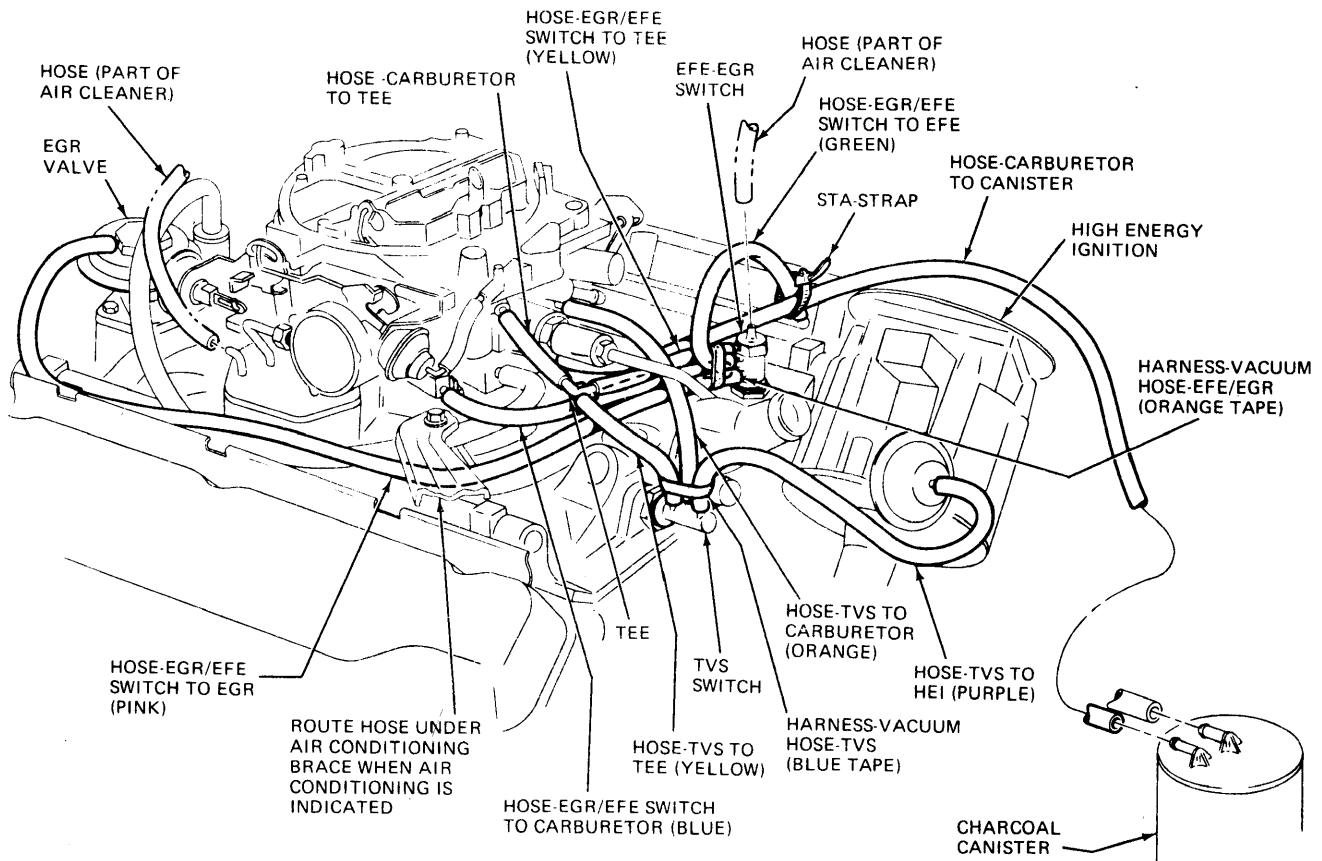

VACUUM HOSE ROUTING, 350" V8 W/4-Bbl. (WITHOUT A.I.R.)

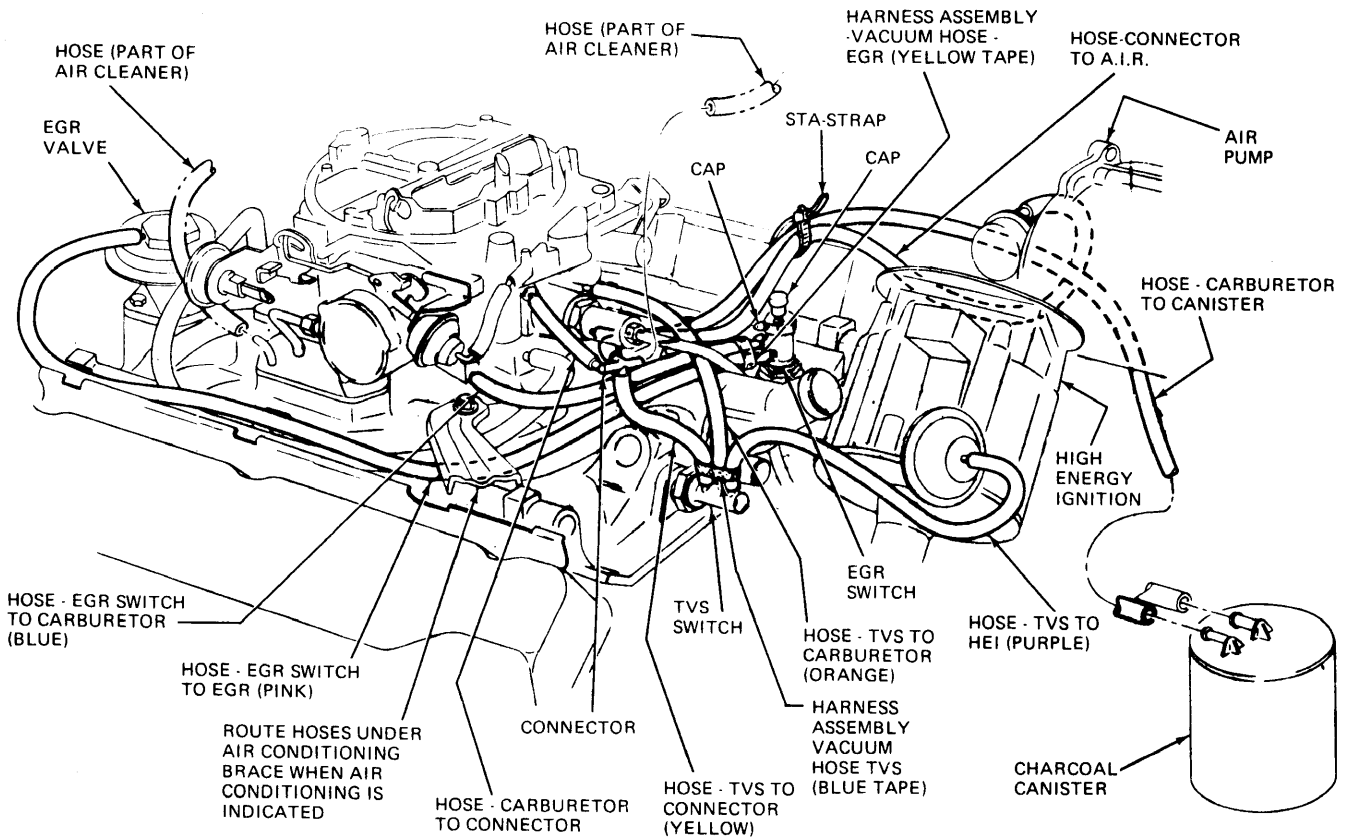

VACUUM HOSE ROUTING, 350" V8 W/4-Bbl. & A.I.R. (WITHOUT EFE)

1975 EXHAUST EMISSIONS SYSTEMS

Buick Vacuum Diagrams (Cont.)

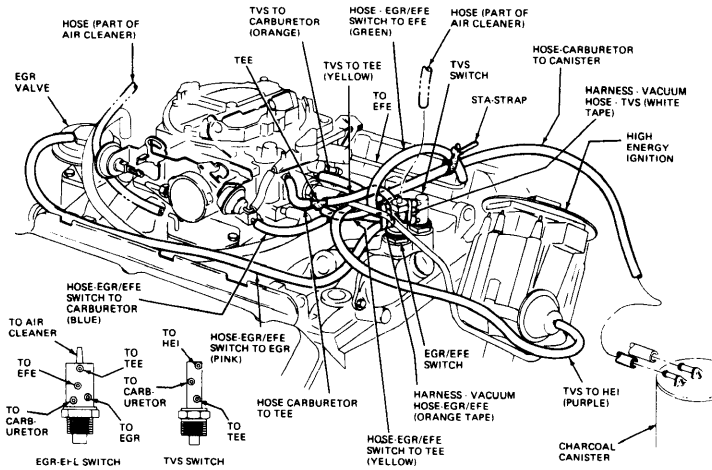

VACUUM HOSE ROUTING, 455" V8

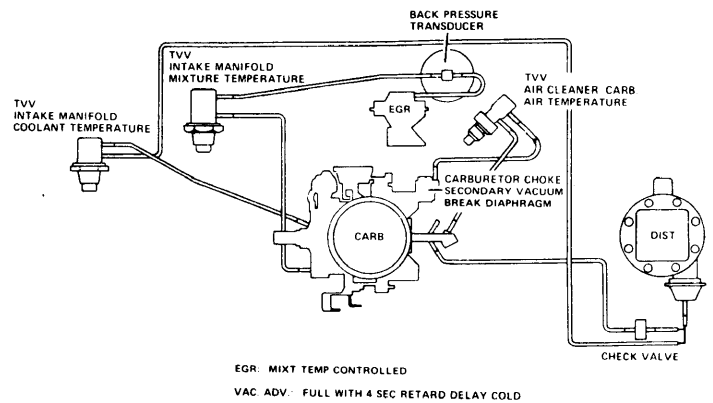

VACUUM HOSE ROUTING, 400" V8 (CALIF.)

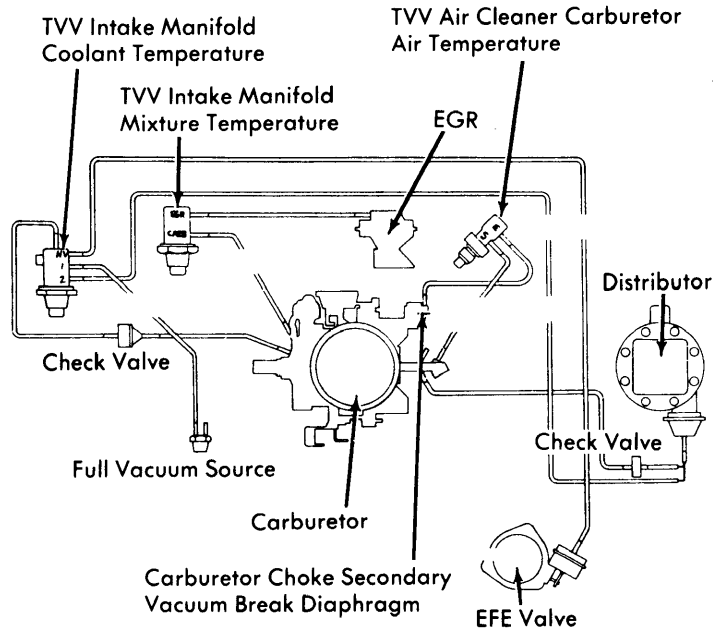

EGR: Mixture Temperature Controlled
 Vacuum Advance: Full, With 4 Second Retard Delay

VACUUM HOSE ROUTING, 400" V8 (FEDERAL)

1975 EXHAUST EMISSIONS SYSTEMS Cadillac Vacuum Diagrams

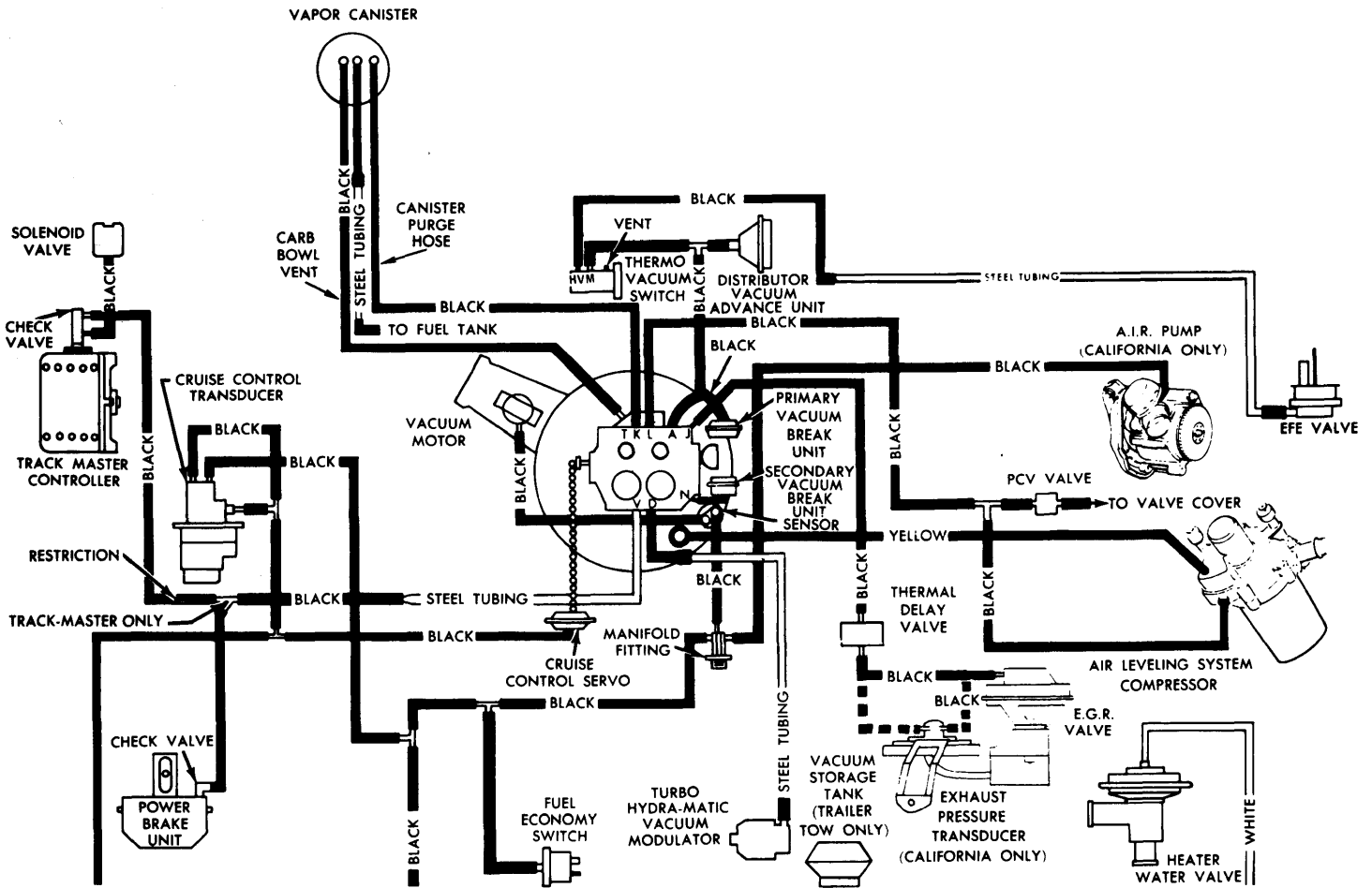

CADILLAC EMISSION CONTROL SYSTEMS

Chevrolet Vacuum Diagrams

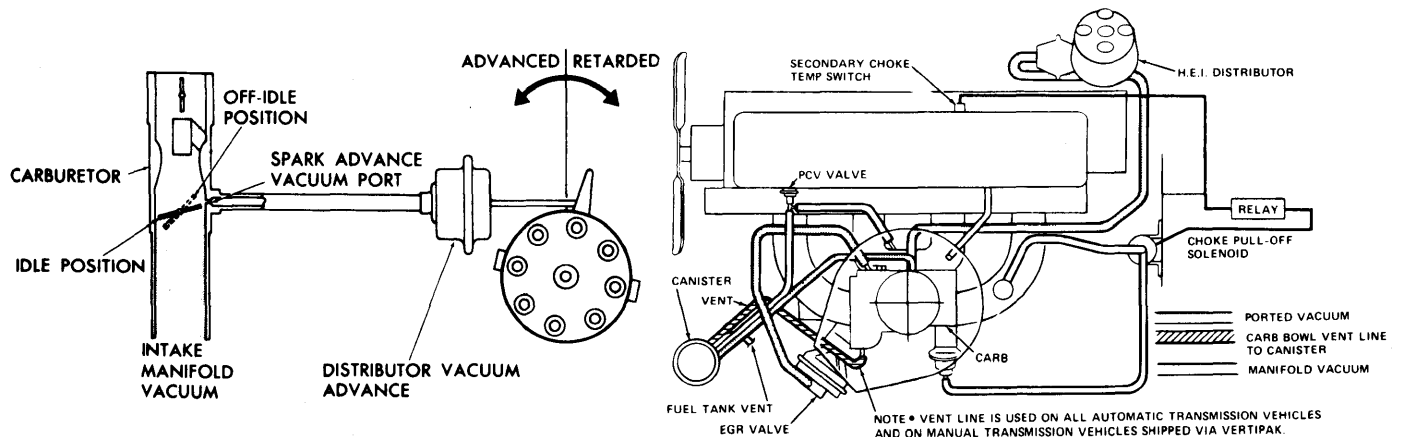

PORTED VACUUM ADVANCE
(TYPICAL CHEVROLET SHOWN)

VACUUM HOSE ROUTING, 140" 4-CYL.
1-BBL. (MONZA TOWN COUPE SHOWN)

1975 EXHAUST EMISSIONS SYSTEMS Chevrolet Vacuum Diagrams (Cont.)

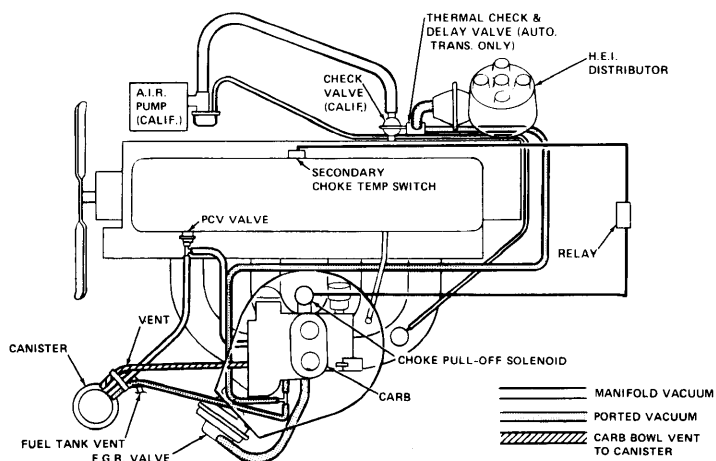

**VACUUM HOSE ROUTING, 140" 4-CYL.
2-BBL. (MONZA TOWN COUPE SHOWN)**

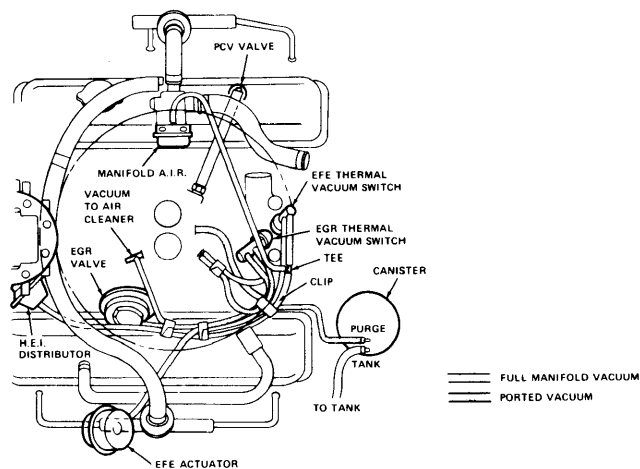

**VACUUM HOSE ROUTING 260" V8
(MONZA TOWN COUPE SHOWN)**

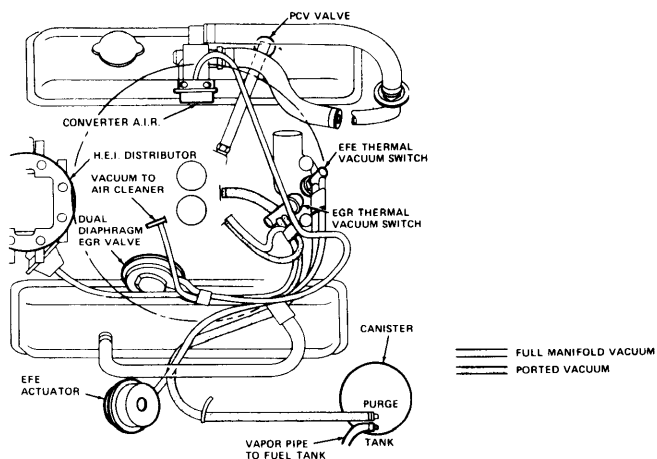

**VACUUM HOSE ROUTING, 350" V8
(MONZA TOWN COUPE SHOWN)**

Oldsmobile Vacuum Diagrams

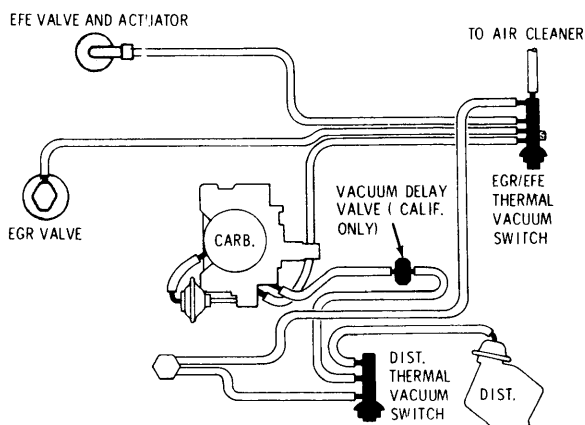

**VACUUM HOSE ROUTING, STARFIRE 231" V6 2-Bbl.
(ALL EARLY PRODUCTION)**

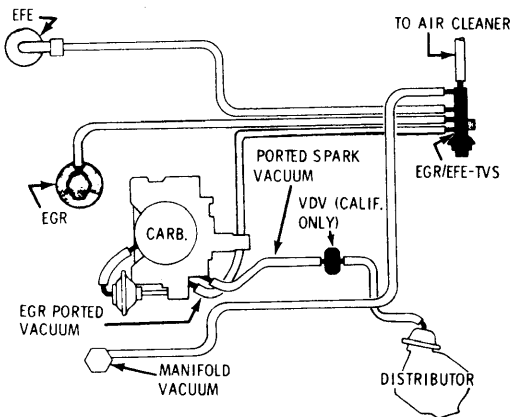

**VACUUM HOSE ROUTING, STARFIRE 231" V6
2-Bbl.**

1975 EXHAUST EMISSIONS SYSTEMS Oldsmobile Vacuum Diagrams (Cont.)

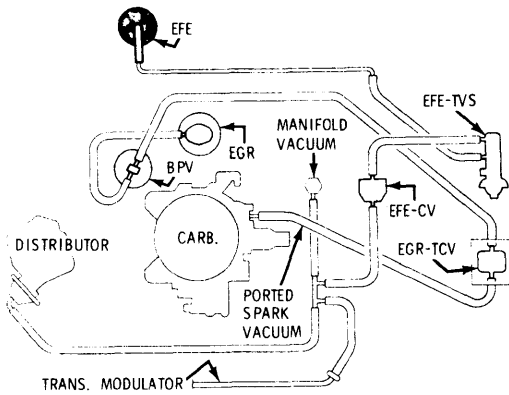

**VACUUM HOSE ROUTING, OMEGA & CUTLASS 260" V8
2-Bbl. (FEDERAL-AUTO. TRANS.)**

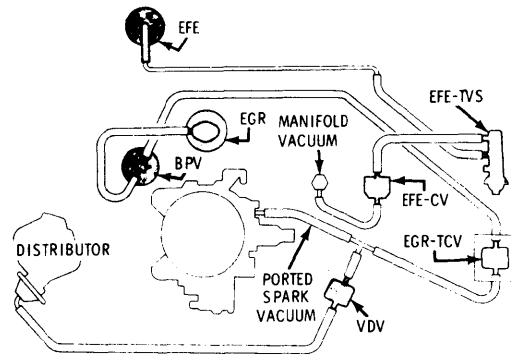

**VACUUM HOSE ROUTING, OMEGA & CUTLASS 260" V8
2-Bbl. (FEDERAL-MAN. TRANS.)**

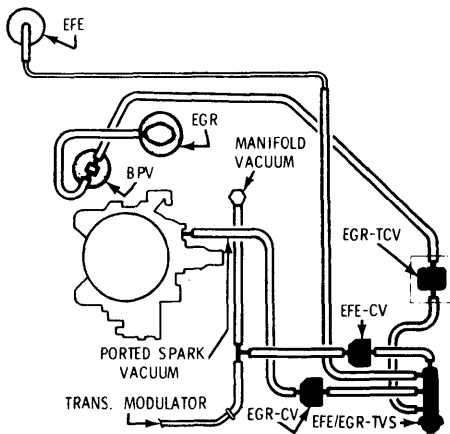

**VACUUM HOSE ROUTING, OMEGA & CUTLASS 260" V8
2-Bbl. (CALIF.-AUTO. TRANS.)**

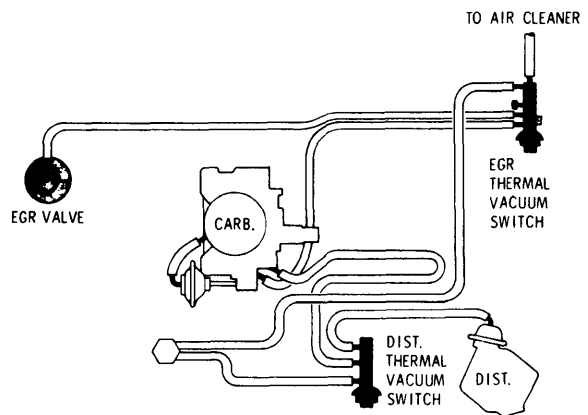

**VACUUM HOSE ROUTING, OMEGA 350" V8
2-Bbl. (FEDERAL)**

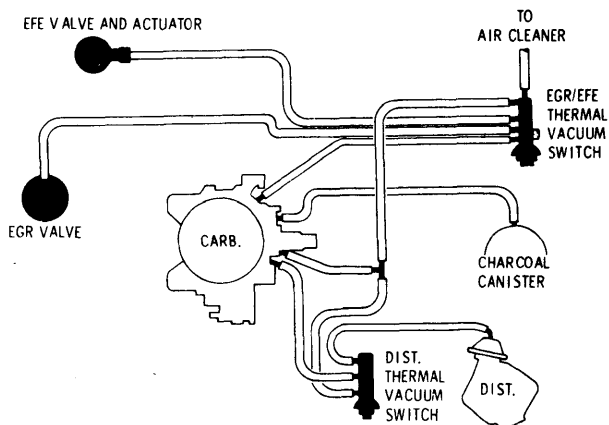

**VACUUM HOSE ROUTING, OMEGA 350" V8
4-Bbl. (FEDERAL)**

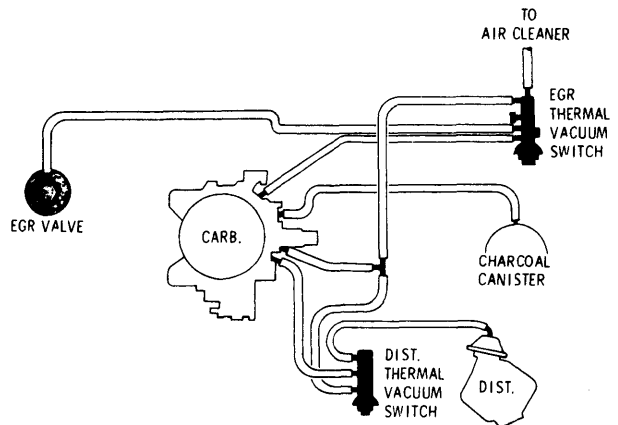

**VACUUM HOSE ROUTING, OMEGA 350" V8
4-Bbl. (CALIF.)**

1975 EXHAUST EMISSIONS SYSTEMS Oldsmobile Vacuum Diagrams (Cont.)

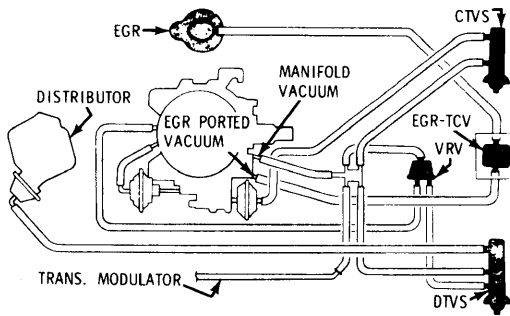

50L044

**VACUUM HOSE ROUTING, CUTLASS, 88 350" V8
4-Bbl. & TORONADO 455" V8 4-Bbl. (EARLY
PRODUCTION-FEDERAL)**

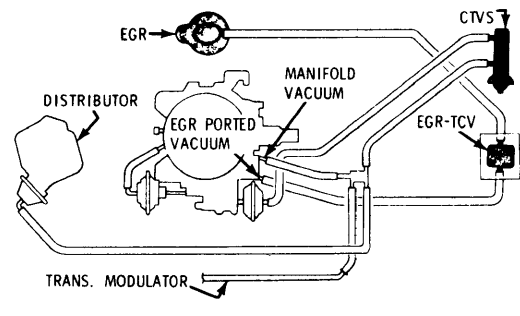

50L045

**VACUUM HOSE ROUTING, CUTLASS, 88, 350" V8
4-Bbl. & TORONADO 455" V8 4-Bbl. (FEDERAL)**

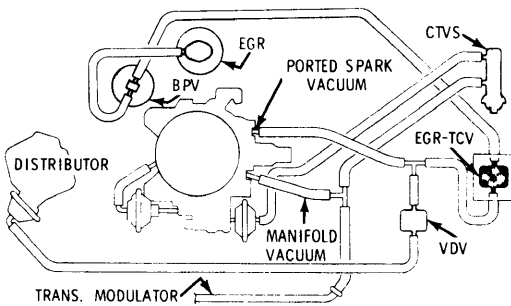

50L046

**VACUUM HOSE ROUTING, CUTLASS & 88 350" V8
4-Bbl. (CALIF.)**

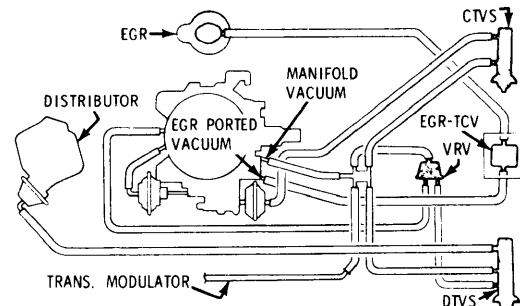

50L047

**VACUUM HOSE ROUTING, CUTLASS, 88 & 98
455" V8 4-Bbl. (FEDERAL)**

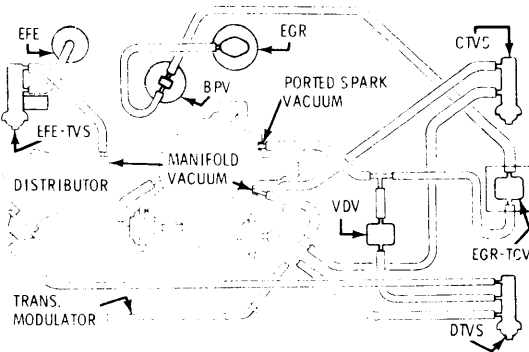

50L048

**VACUUM HOSE ROUTING, CUTLASS, 88 & 98
455" V8 4-Bbl. (CALIF.)**

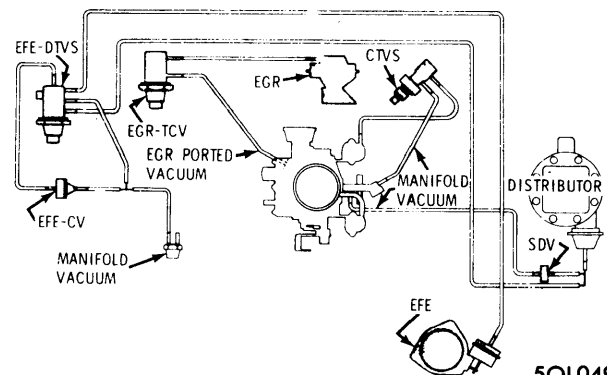

50L049

**VACUUM HOSE ROUTING, ALL 88 W/400" V8
2-Bbl. EXC. STATION WAGON (FEDERAL)**

1975 EXHAUST EMISSIONS SYSTEMS Oldsmobile Vacuum Diagrams (Cont.)

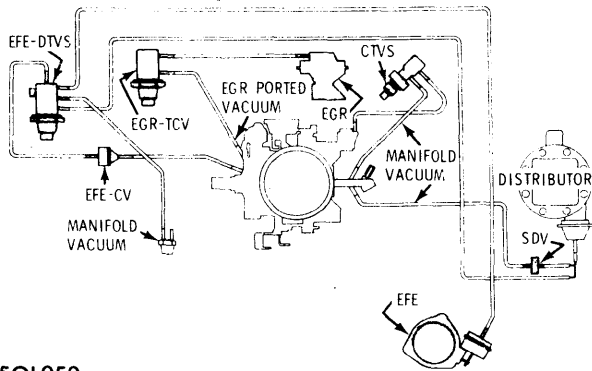

50L050

VACUUM HOSE ROUTING, ALL 88 STATION WAGON
& 98 400" V8 4-Bbl. (FEDERAL)

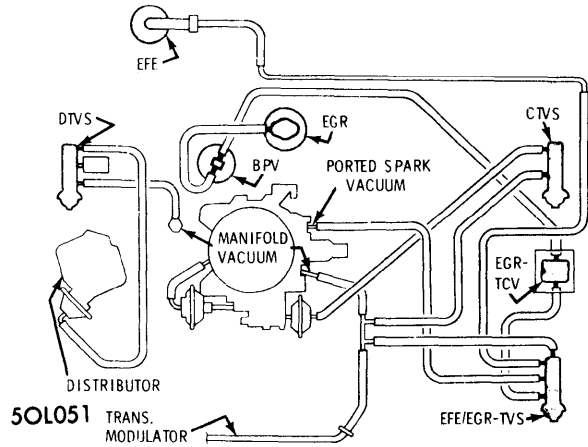

VACUUM HOSE ROUTING, TORONADO 455" V8
4-Bbl. (CALIF.)

Pontiac Vacuum Diagrams

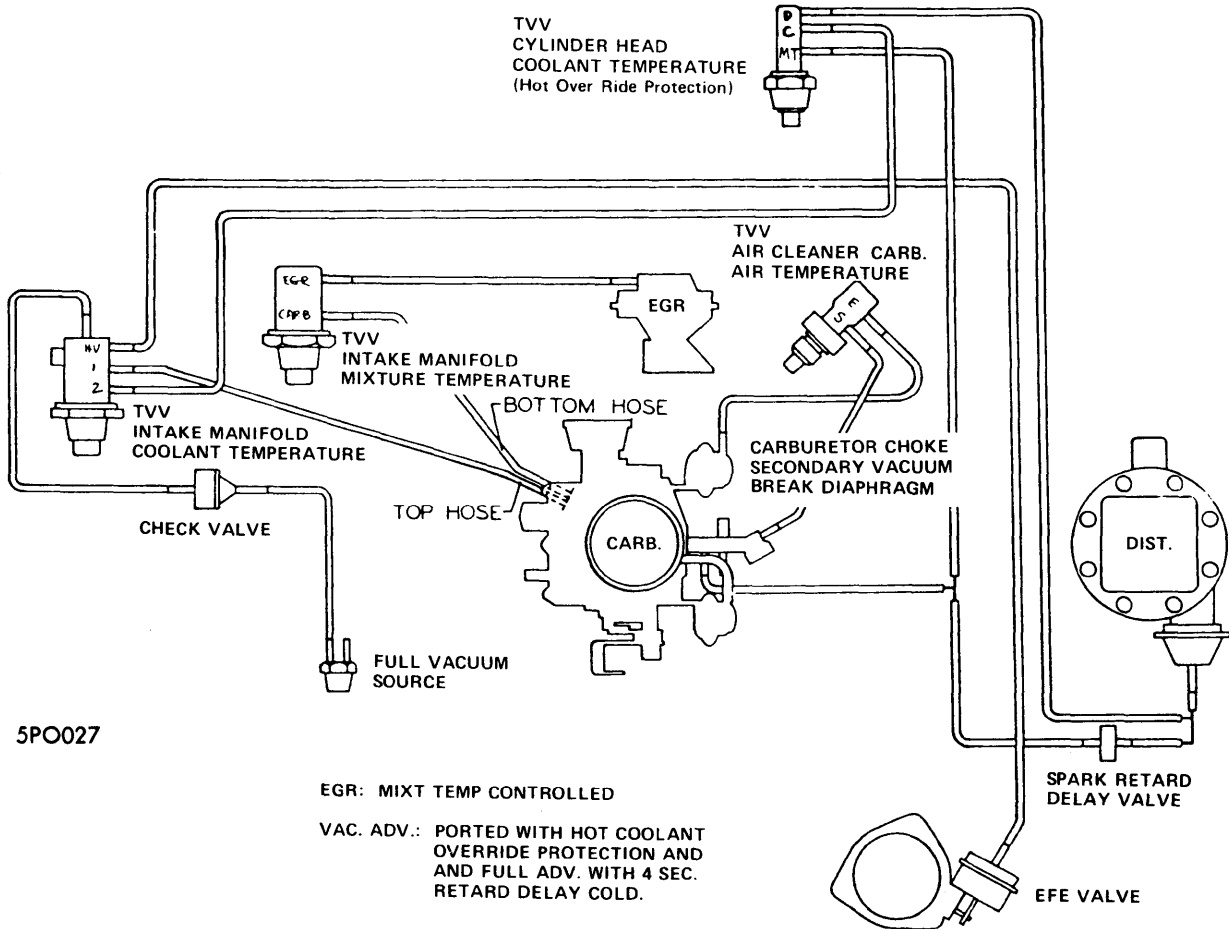

5P0027

VACUUM HOSE ROUTING, 350" V8 2-Bbl., EXC.
VENTURA (FEDERAL)

1975 EXHAUST EMISSIONS SYSTEMS Pontiac Vacuum Diagrams (Cont.)

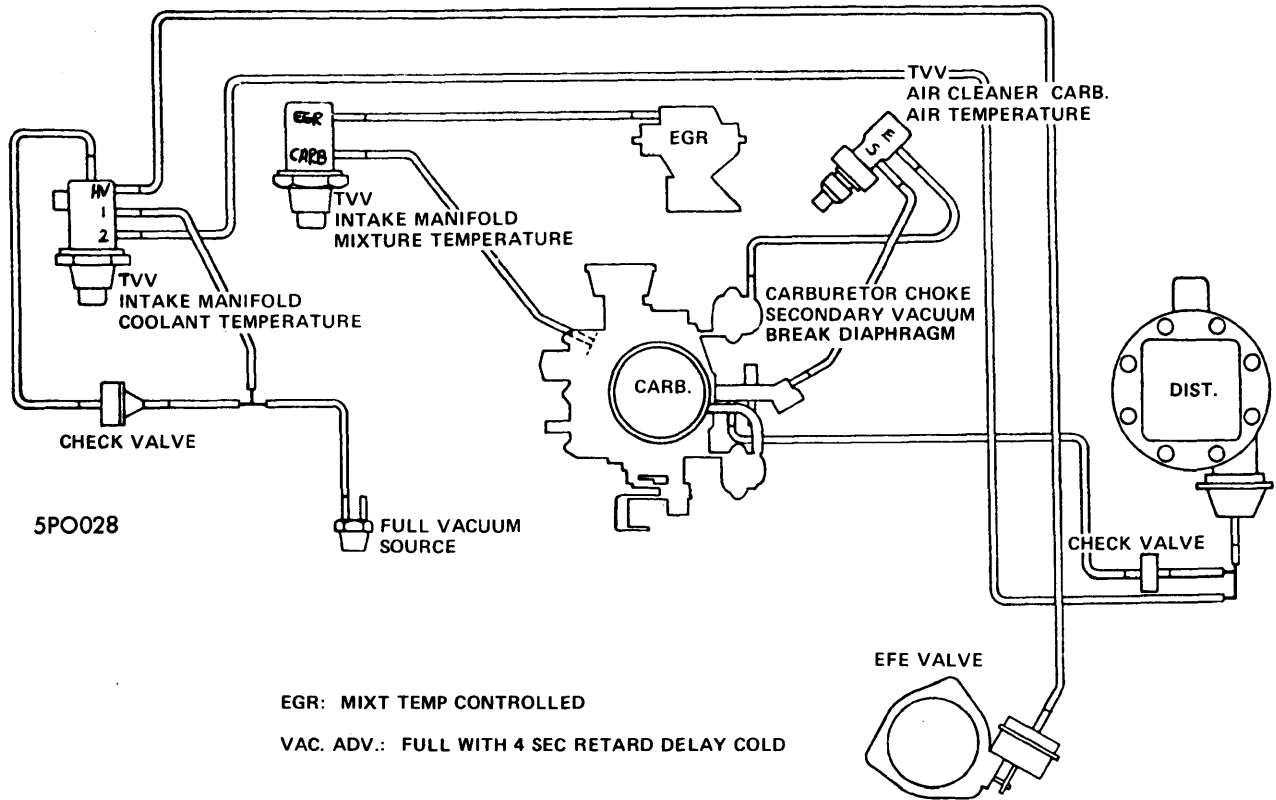

VACUUM HOSE ROUTING, 400" V8 2-Bbl. (FEDERAL)

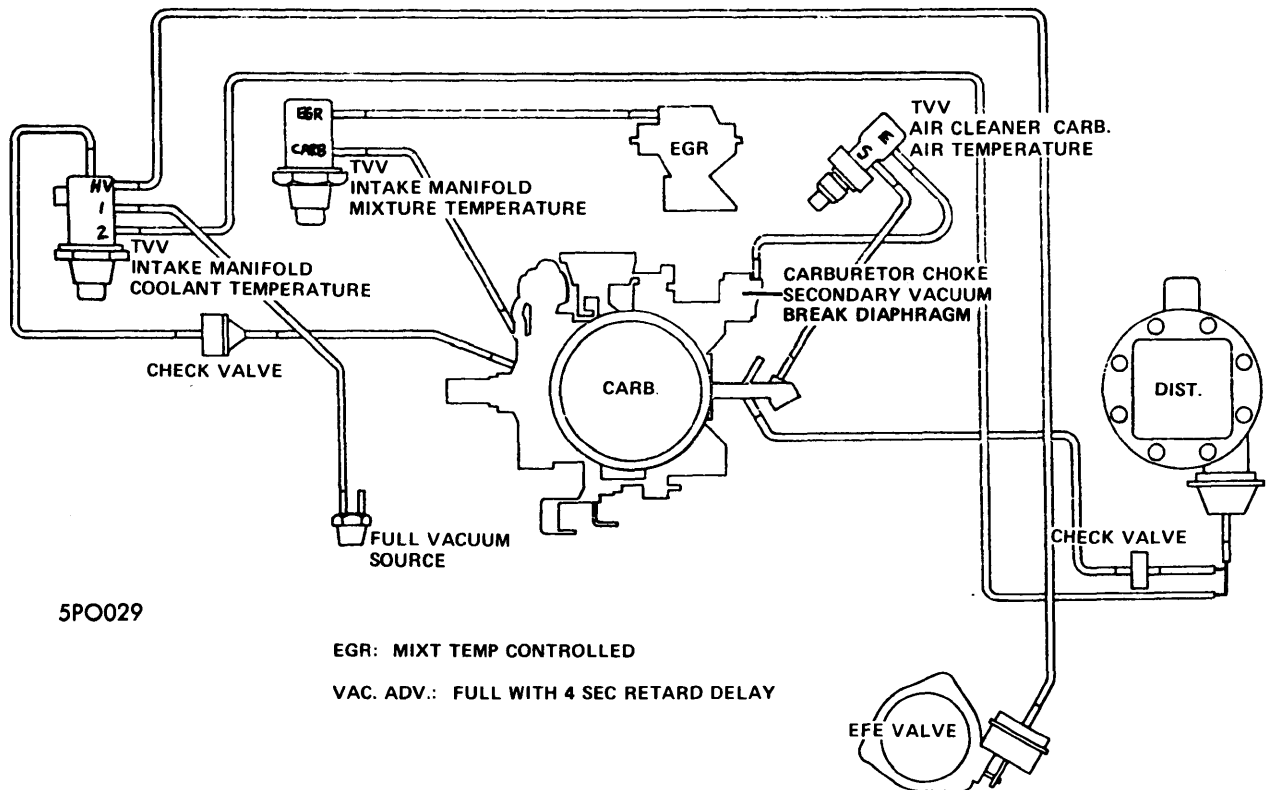

**VACUUM HOSE ROUTING, 350"/400" V8 4-Bbl., EXC.
VENTURA (FEDERAL-AUTO. TRANS.)**

1975 EXHAUST EMISSIONS SYSTEMS Pontiac Vacuum Diagrams (Cont.)

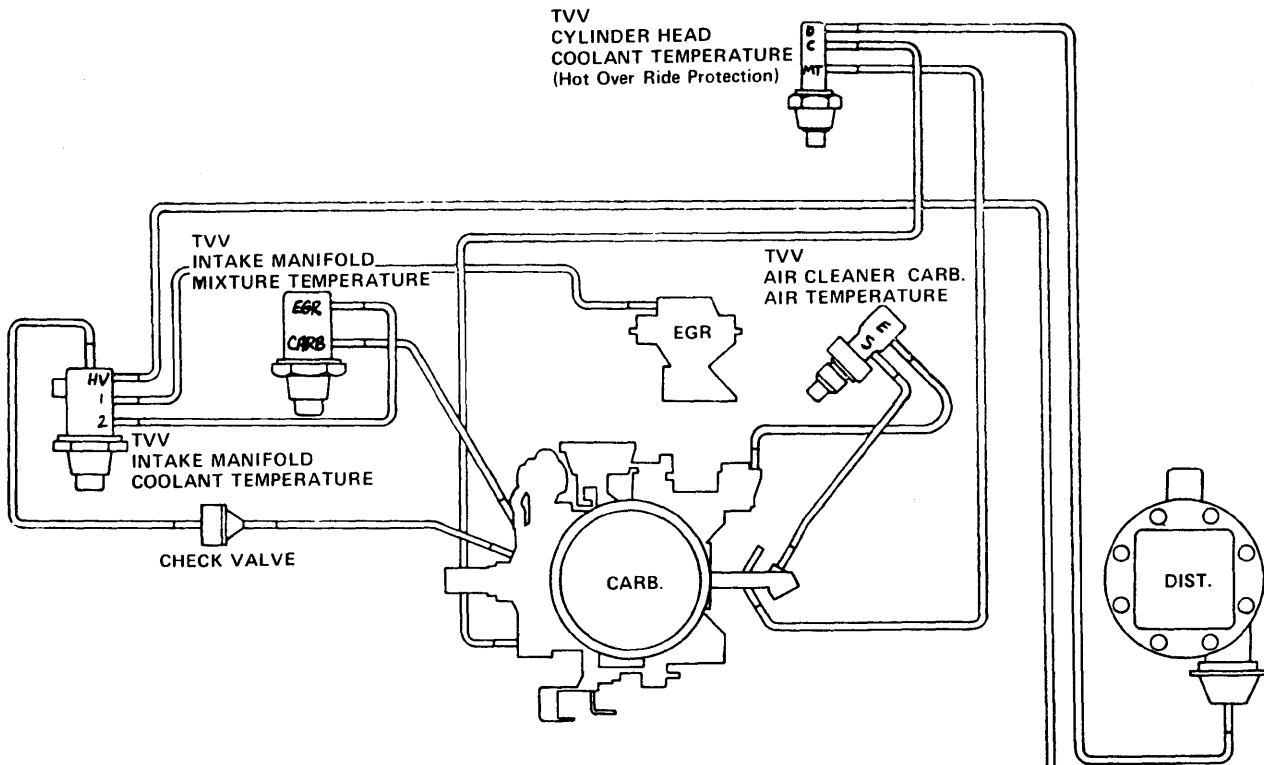

5PO030

EGR: SERIES CONTROLLED

VAC. ADV.: PORTED WITH HOT COOLANT
OVER RIDE PROTECTION

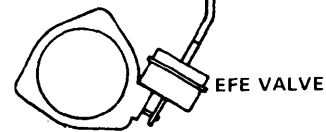

**VACUUM HOSE ROUTING, 350"/400" V8 4-Bbl., EXC.
VENTURA (FEDERAL-MAN. TRANS.)**

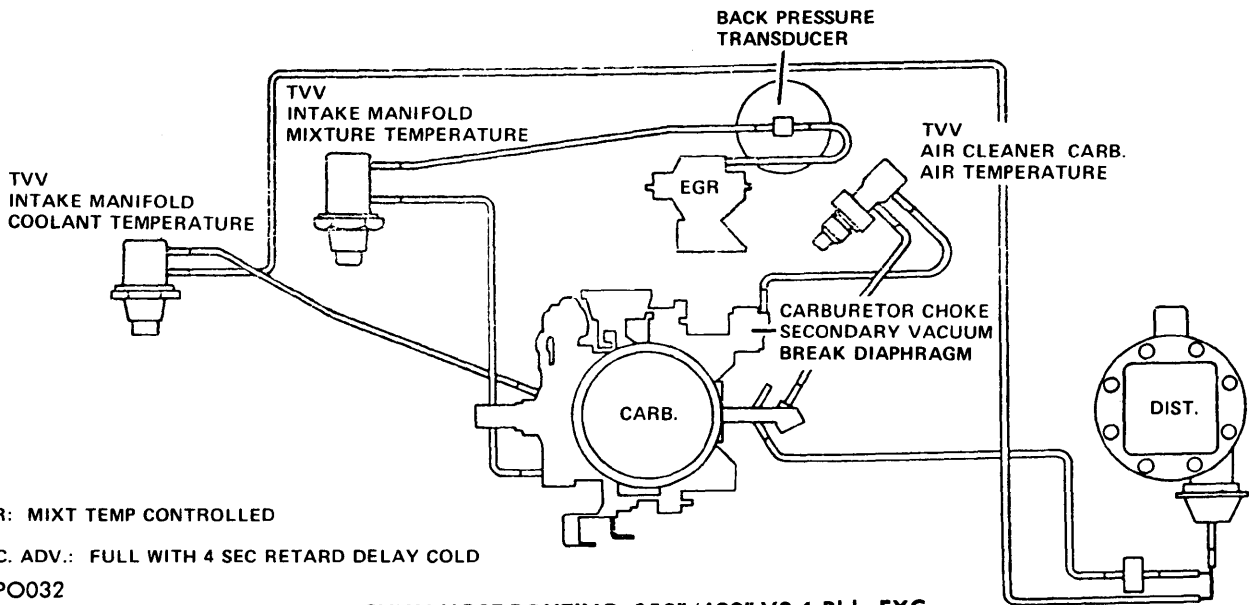

EGR: MIXT TEMP CONTROLLED

VAC. ADV.: FULL WITH 4 SEC RETARD DELAY COLD

5PO032

**VACUUM HOSE ROUTING, 350"/400" V8 4-Bbl., EXC.
VENTURA (CALIF.)**

1975 EXHAUST EMISSIONS SYSTEMS Pontiac Vacuum Diagrams (Cont.)

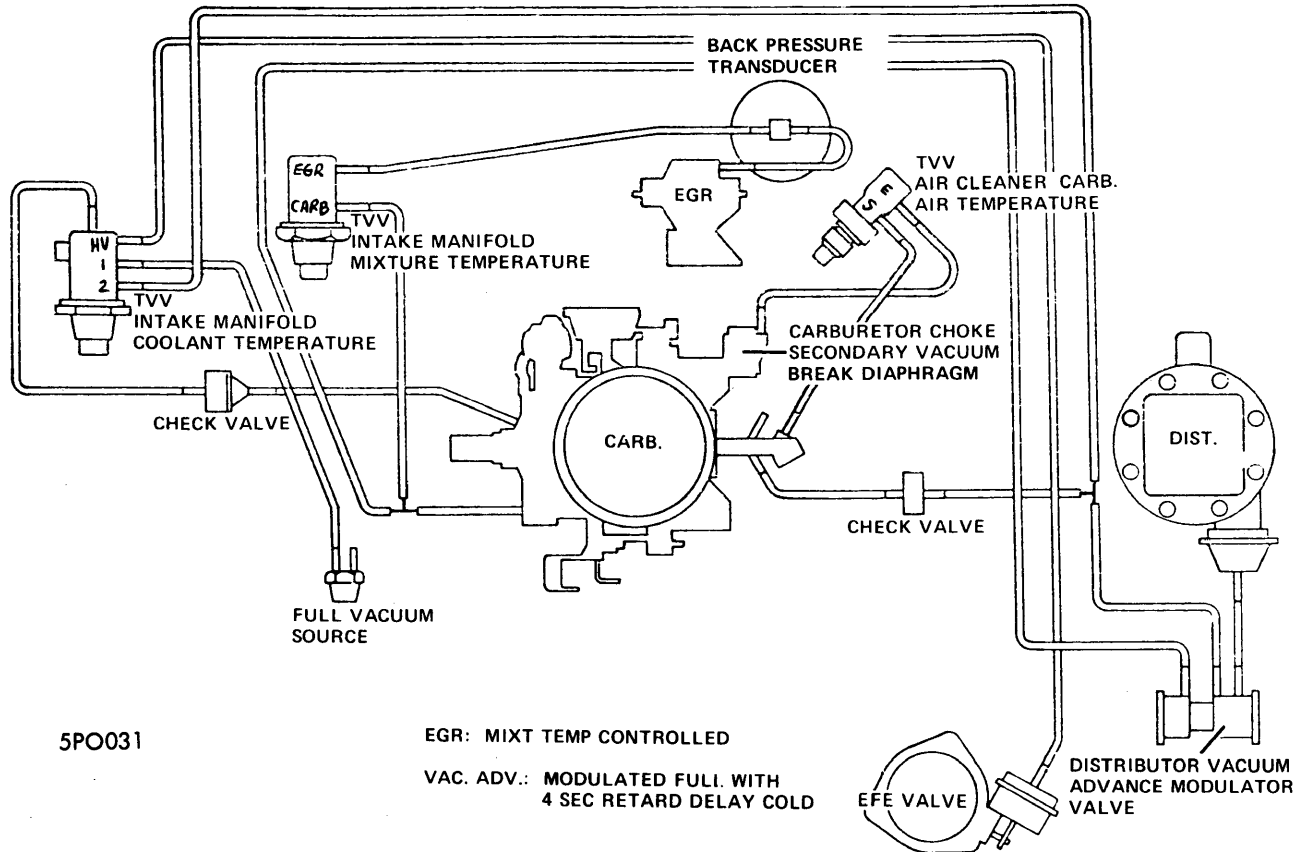

VACUUM HOSE ROUTING, 455" V8 4-Bbl. (FEDERAL)

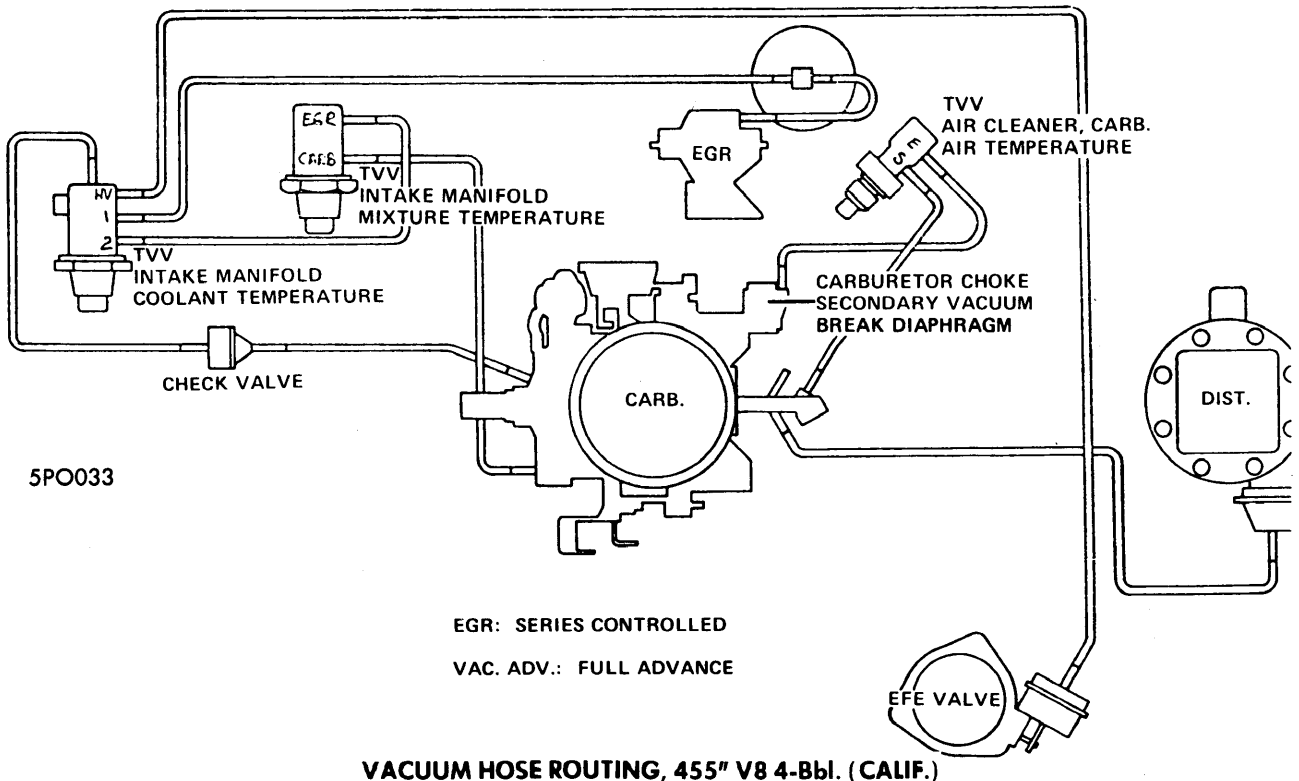

VACUUM HOSE ROUTING, 455" V8 4-Bbl. (CALIF.)

1975 EXHAUST EMISSIONS SYSTEMS Pontiac Vacuum Diagrams (Cont.)

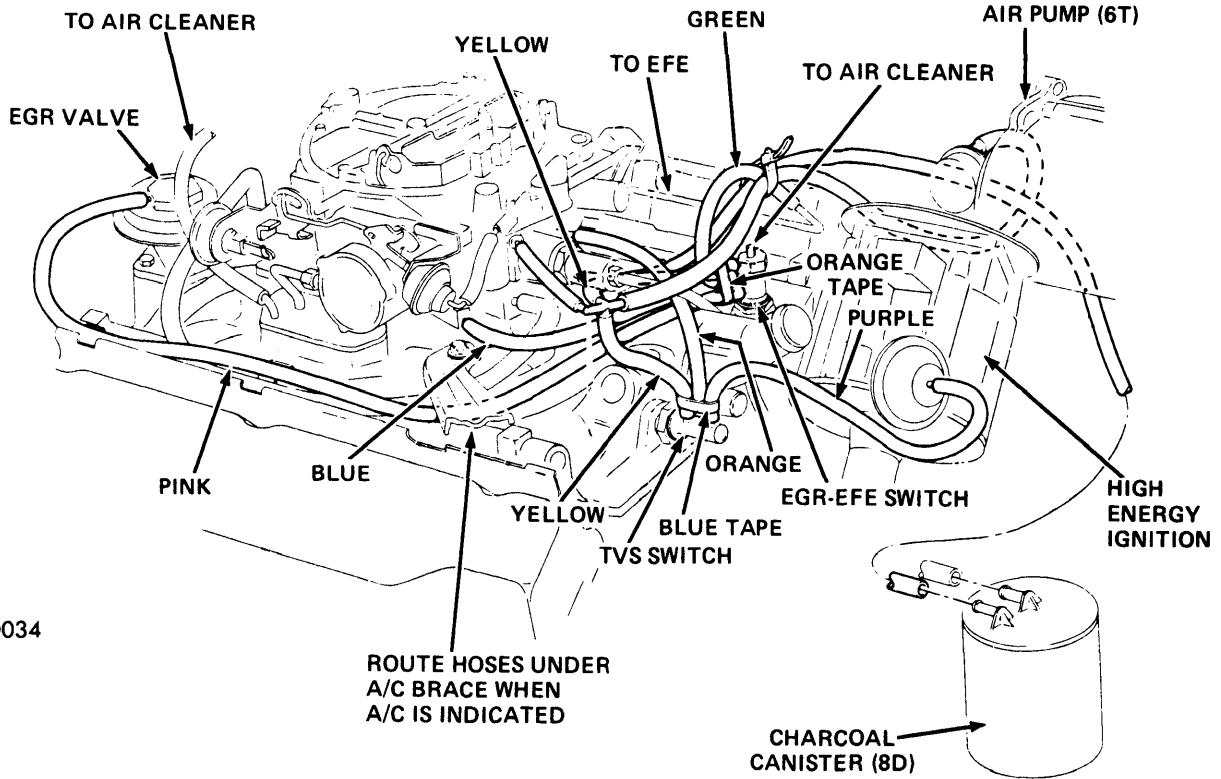

5PO034

VACUUM HOSE ROUTING, 350" V8 4-Bbl. VENTURA
(WITH A.I.R.)

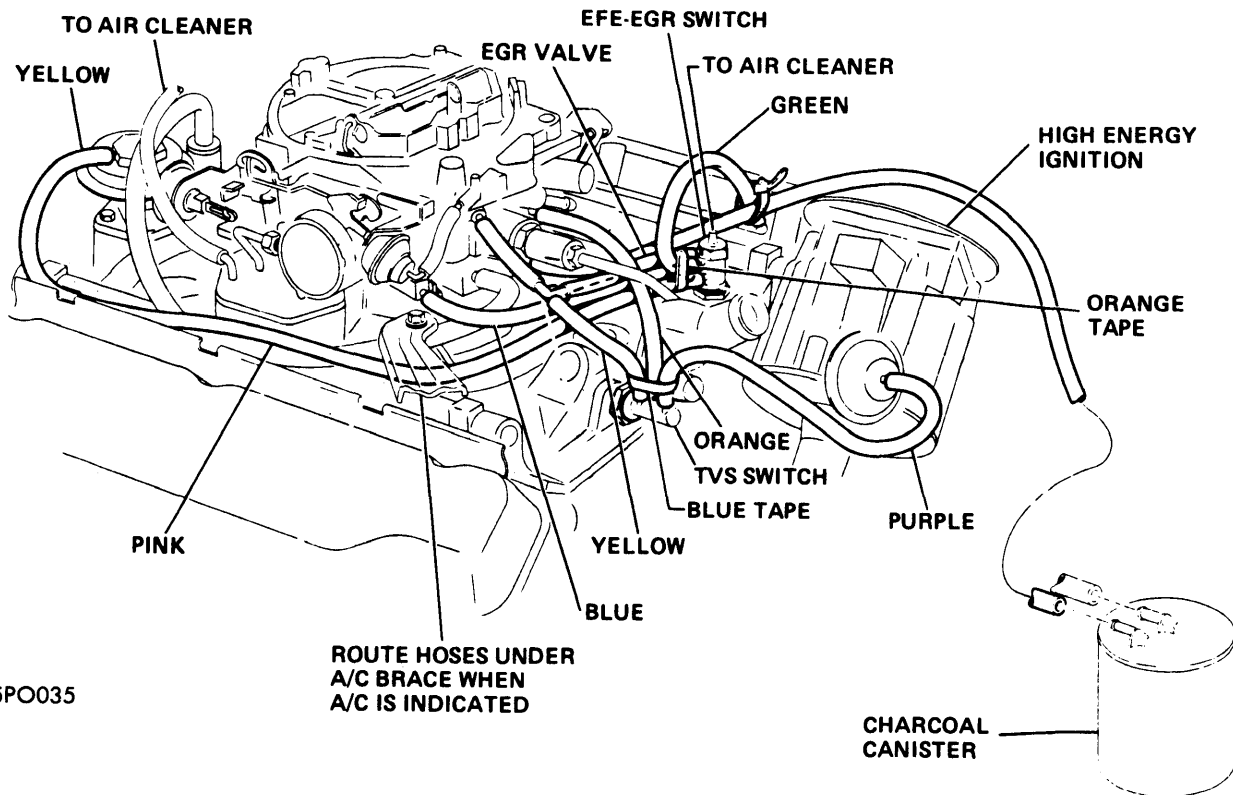

5PO035

VACUUM HOSE ROUTING, 350" V8 4-Bbl. VENTURA
(WITHOUT A.I.R.)

1975 EXHAUST EMISSIONS SYSTEMS Pontiac Vacuum Diagrams (Cont.)

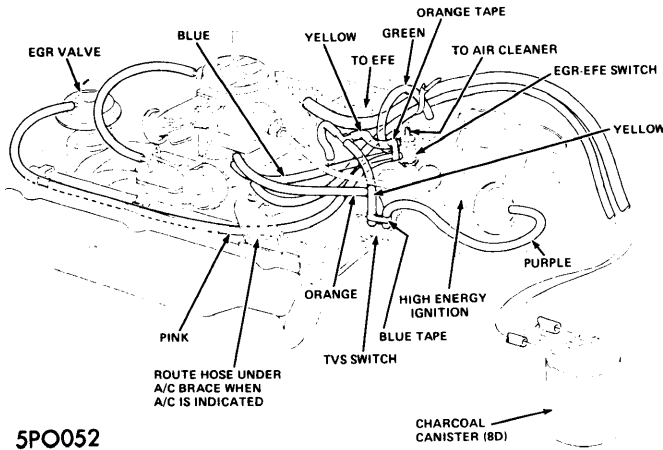

5PO052

**VACUUM HOSE ROUTING, 350" V8 2-BBL.
(WITHOUT A.I.R.)**

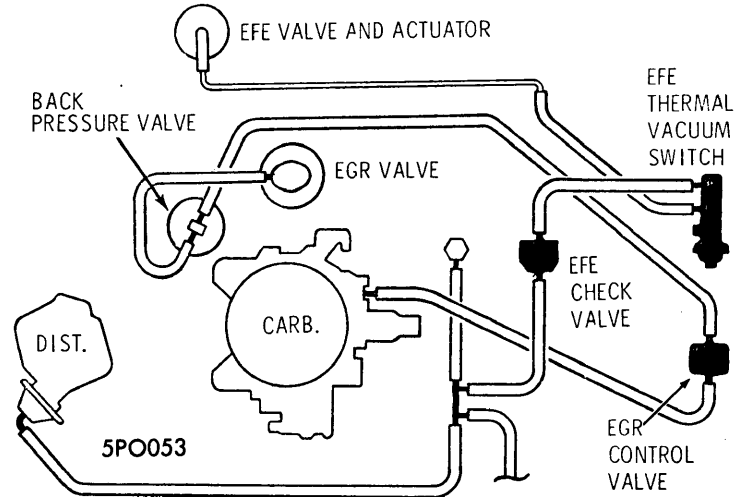

5PO053

**VACUUM HOSE ROUTING, 260" V8
VENTURA (AUTO. TRANS.-FEDERAL)**

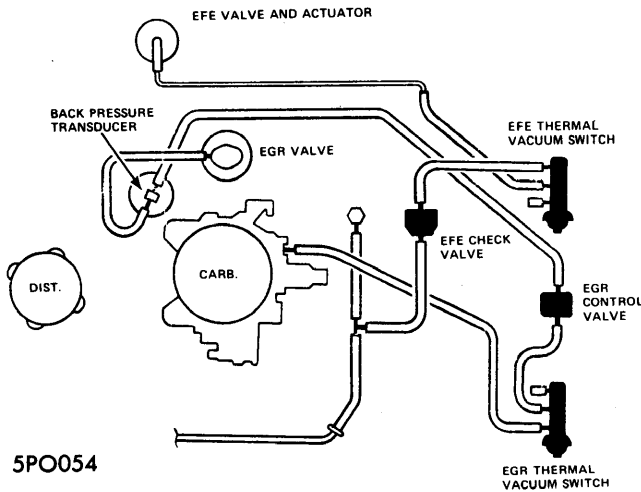

5PO054

**VACUUM HOSE ROUTING, 260" V8
VENTURA (AUTO. TRANS.-CALIF.)**

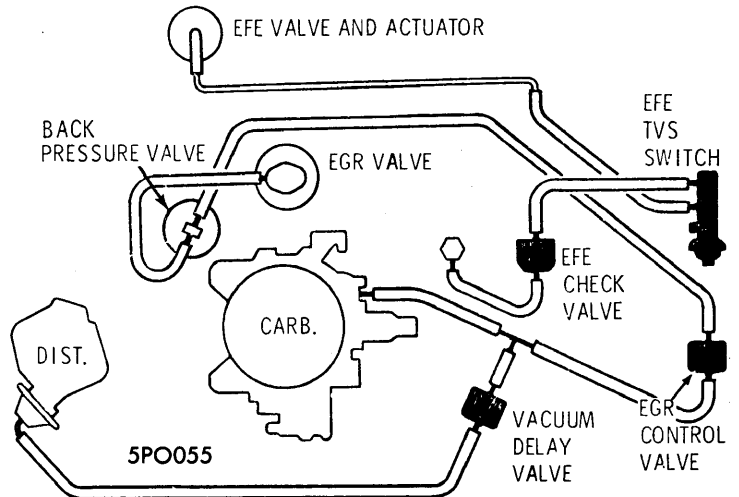

5PO055

**VACUUM HOSE ROUTING, 260" V8
VENTURA (MAN. TRANS.-FEDERAL)**