

1979 EXHAUST EMISSION SYSTEMS

Ford Motor Co. Vacuum Diagram Index

Calibration	Fig. No.	Calibration	Fig. No.
2.3L 4 Cyl.		2.8L V6 (Cont.)	
Calif. Auto. Trans.		Federal Man. Trans.	
9-1P-R0	1	9-3A-R0	34
9-1S-R0	2	200" 6 Cyl.	
9-1S-R10	3	Calif. Auto. Trans.	
9-1V-R0	4	9-7N-R2	44
9-1V-R10	5	9-7N-R3	44
Calif. Man. Trans.		9-7Z-R10	45
9-2N-R0	20	Federal Auto. Trans.	
9-2P-R0	21	9-7A-R0	40
9-2R-R0	22	9-7A-R10	41
9-2S-R0	23	9-7A-R11	42
9-2S-R2	24	9-7A-R12	42
9-2S-R10	25	9-7A-R13	42
9-2S-R11	23	9-7D-R0	43
9-2S-R12	25	Federal Man. Trans.	
9-2T-R0	26	9-6A-R0	38
9-2V-R0	27	9-6A-R10	39
9-2V-R10	28	250" 6 Cyl.	
9-2V-R12	28	Calif. Auto. Trans.	
Federal Auto. Trans.		9-9P-R0	49
9-1X-R0	6	9-9P-R10	49
9-21B-R0	31	9-9P-R11	49
9-21B-R10	32	9-29B-R11	50
9-21C-R0	33	Federal Auto. Trans.	
Federal Man. Trans.		9-9A-R0	47
9-2A-R0	7	9-9A-R13	48
9-2A-R10	8	9-9A-R14	47
9-2A-R12	9	Federal Man. Trans.	
9-2B-R0	10	9-8A-R0	46
9-2B-R10	11	9-8A-R10	46
9-2B-R13	12	302" V8	
9-2C-R0	13	Calif. Auto. Trans.	
9-2C-R10	14	8-11L-R11	52
9-2D-R0	15	8-11L-R20	53
9-2E-R0	16	9-11E-R1	64
9-2E-R12	16	9-11E-R10	65
9-2F-R0	17	9-11N-R0	69
9-2F-R11	18	9-11N-R10	70
9-2F-R13	19	9-11P-R0	71
High Altitude Man. Trans.		9-11P-R2	72
9-2X-R0	29	9-11Q-R1	73
9-2Y-R0	30	9-11Q-R15	74
2.8L V6		9-11R-R0	75
Calif. Auto. Trans.		9-11R-R10	75
9-4N-R0	37	9-11S-R0	76
Federal Auto. Trans.		9-11V-R0	77
9-4A-R0	35	9-11V-R10	78
9-4A-R10	35		
9-4A-R11	36		
9-4A-R12	36		

1979 EXHAUST EMISSION SYSTEMS

Ford Motor Co. Vacuum Diagram Index (Cont.)

Calibration	Fig. No.
302" V8 (Cont.)	
Federal Auto. Trans.	
8-11D-R0	51
9-11A-R0	57
9-11A-R10	57
9-11A-R20	58
9-11B-R0	59
9-11B-R10	60
9-11B-R11	61
9-11C-R1	62
9-11C-R10	62
9-11D-R11	63
9-11E-R13	66
9-11F-R1	67
9-11J-R10	68
9-11J-R13	68
Federal Man. Trans.	
9-10A-R0	54
9-10B-R0	55
9-10C-R0	56
9-10C-R11	56
High Altitude Auto. Trans.	
9-11X-R10	79
9-11Y-R0	80
9-11Z-R0	81
351" M V8	
Calif. Auto. Trans.	
9-14Q-R10	88
High Altitude Auto. Trans.	
9-14X-R0	89
Federal Auto. Trans.	
9-14E-R0	82
9-14E-R12	83
9-14E-R14	84
9-14E-R15	85

Calibration	Fig. No.
351" M V8 (Cont.)	
9-14E-R18	86
9-14Q-R0	87
351" W V8	
Calif. Auto. Trans.	
9-12N-R0	100
9-12P-R0	101
9-12P-R10	102
High Altitude Auto. Trans.	
9-12X-R0	103
9-12X-R10	104
Federal Auto. Trans.	
9-12A-R0	90
9-12B-R0	91
9-12B-R10	92
9-12E-R0	93
9-12E-R14	94
9-12F-R0	95
9-12G-R0	96
9-12G-R12	97
9-12H-R12	98
9-12H-R15	99
400" V8	
Calif. Auto. Trans.	
9-17P-R0	108
9-17P-R10	109
9-17Q-R0	110
High Altitude Auto. Trans.	
9-17X-R0	111
Federal Auto. Trans.	
9-17F-R0	105
9-17F-R1	106
9-17F-R21	107

CALIBRATION NUMBER IDENTIFICATION

To identify the calibration number of an engine installed in a vehicle, find the engine code label. On V6 and V8 engines, the label is located on the front of the left valve cover and the side of the right valve cover. On 4 and 6 cylinder engines, the code label is on the front of the valve cover.

Refer to the illustration to identify the calibration number. Using engine displacement and the calibration number, find the proper vacuum diagram in this index.

NOTE — Some Ford Motor Co. calibration numbers are carried over from 1978; the first digit of these numbers will be an "8". All other codes should begin with a "9".

NOTE — See the 1979 Emission Control Application tables for a list of the abbreviations used on Ford Motor Co. vacuum diagrams.

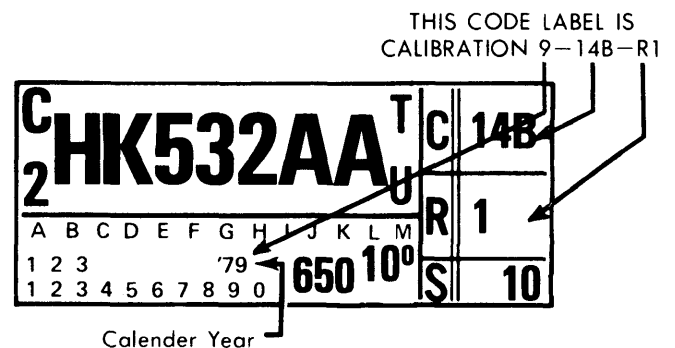

1979 EXHAUST EMISSION SYSTEMS Ford Motor Co. Vacuum Diagrams

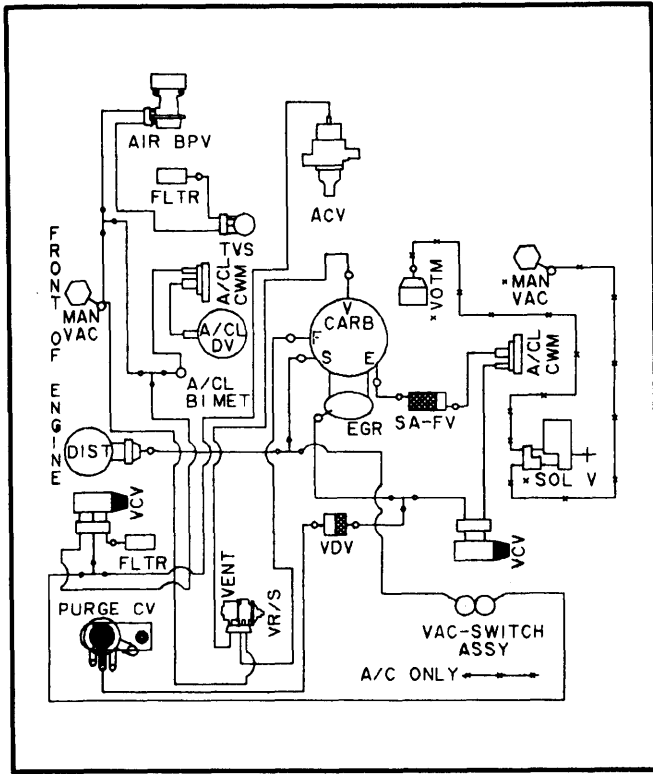

Fig. 1 Calibration 9-1P-R0; 2.3L; Federal

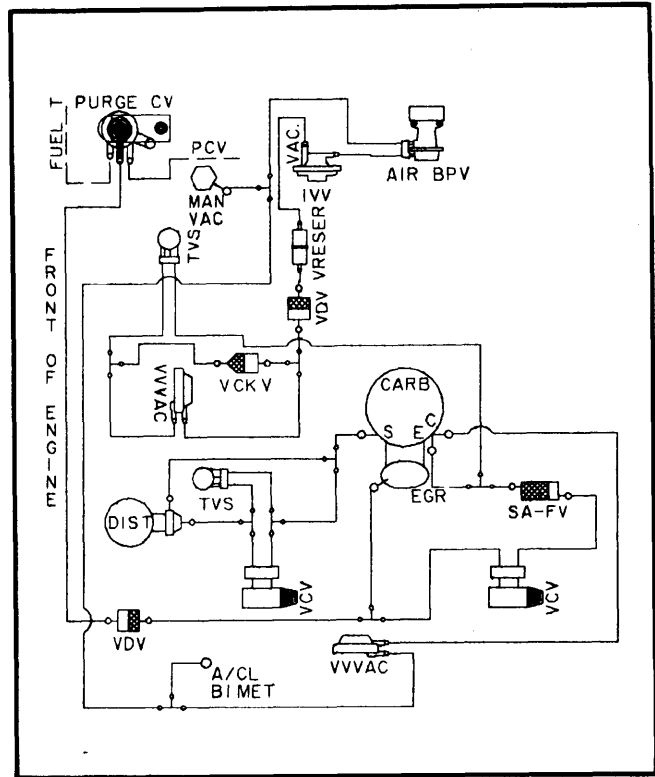

Fig. 2 Calibration 9-1S-R0; 2.3L; Calif.

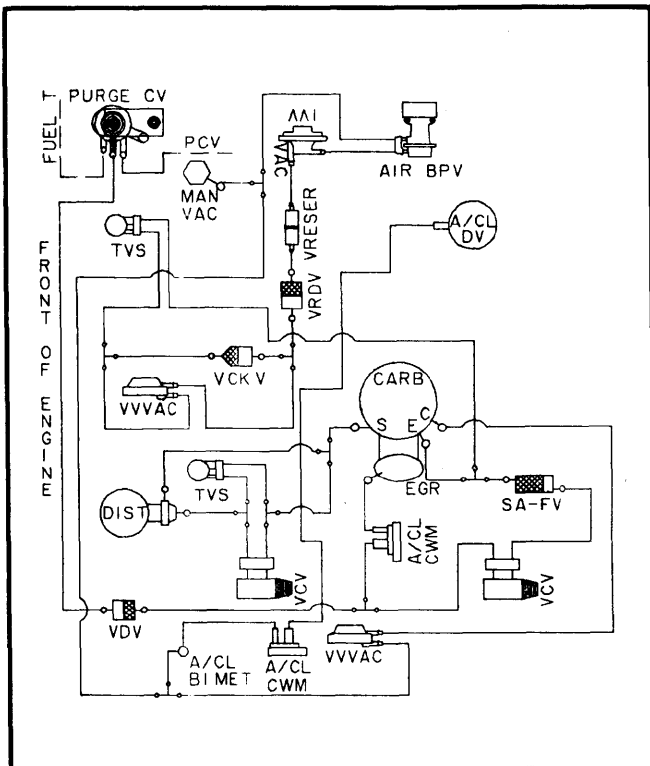

Fig. 3 Calibration 9-1S-R10; 2.3L; Calif.

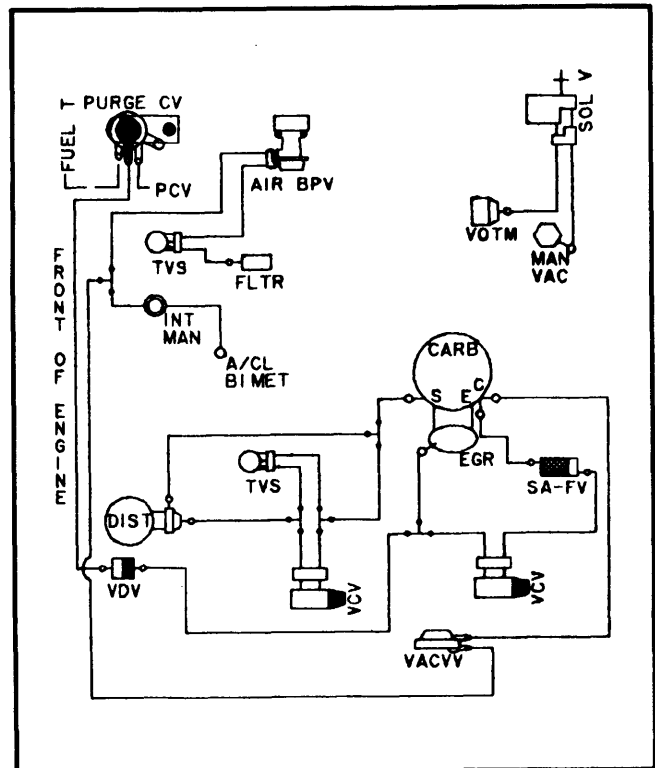

Fig. 4 Calibration 9-1V-R0; 2.3L; Calif.

1979 EXHAUST EMISSION SYSTEMS Ford Motor Co. Vacuum Diagrams (Cont.)

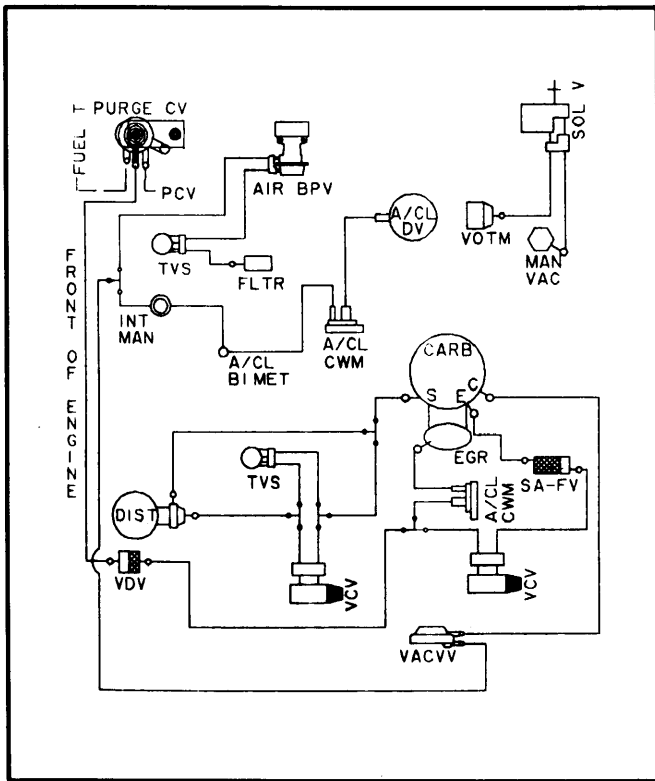

Fig. 5 Calibration 9-1V-R10; 2.3L; Calif.

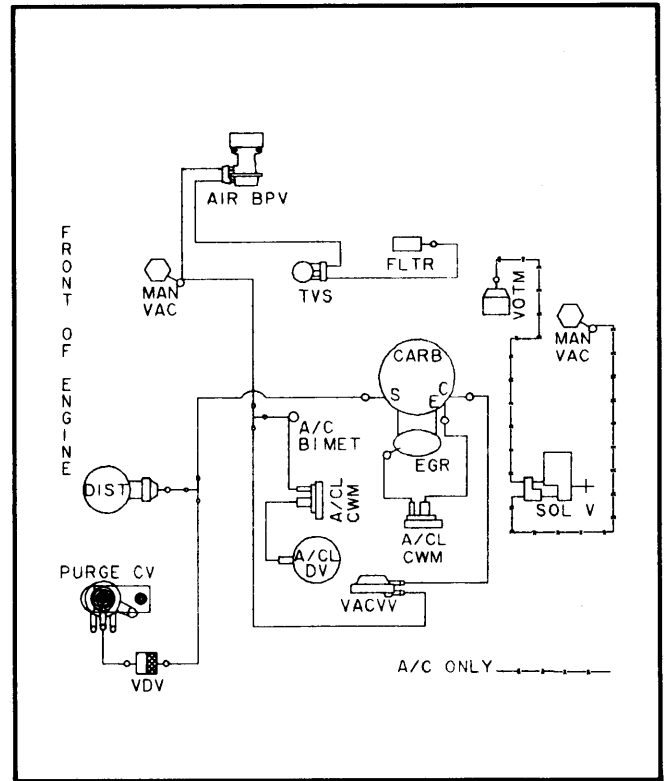

Fig. 6 Calibration 9-1X-R0; 2.3L; Federal

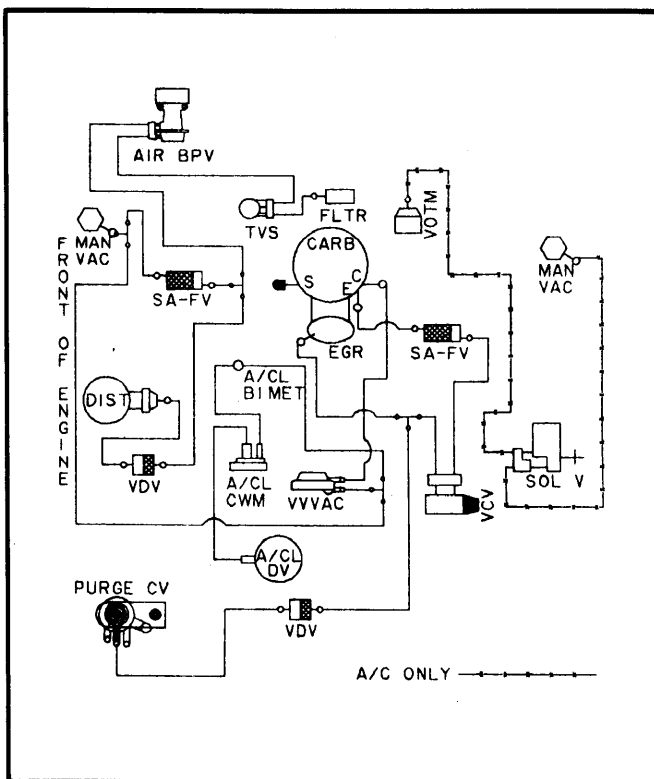

Fig. 7 Calibration 9-2A-R0; 2.3L; Federal

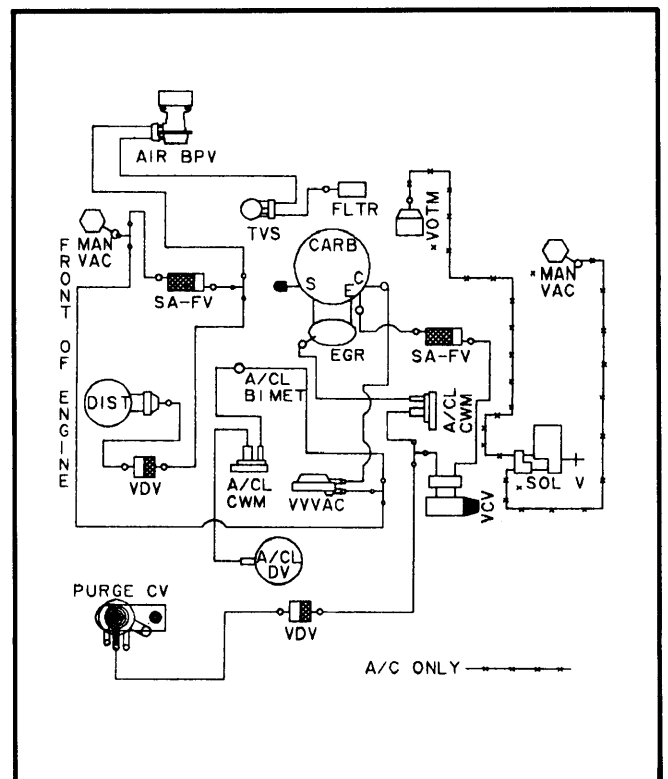

Fig. 8 Calibration 9-2A-R10; 2.3L; Federal

1979 EXHAUST EMISSION SYSTEMS Ford Motor Co. Vacuum Diagrams (Cont.)

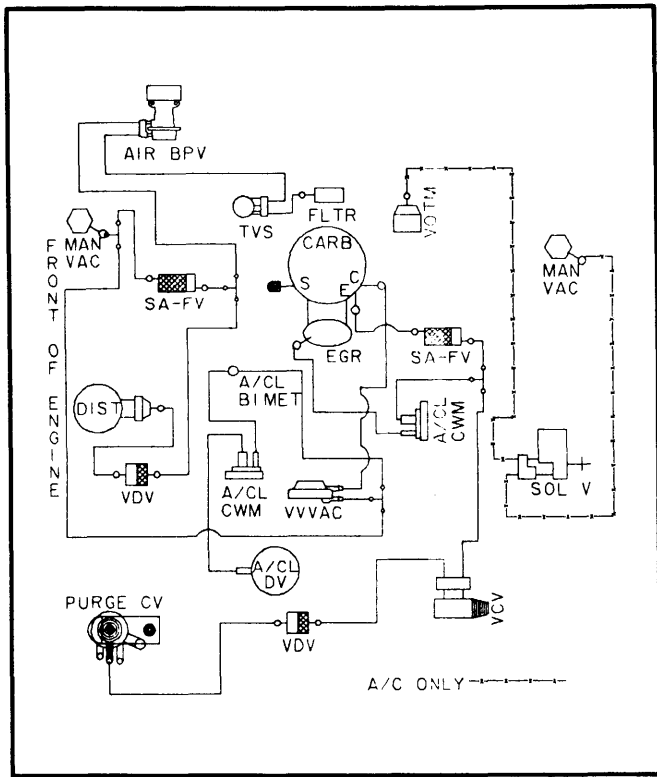

Fig. 9 Calibration 9-2A-R12; 2.3L; Federal

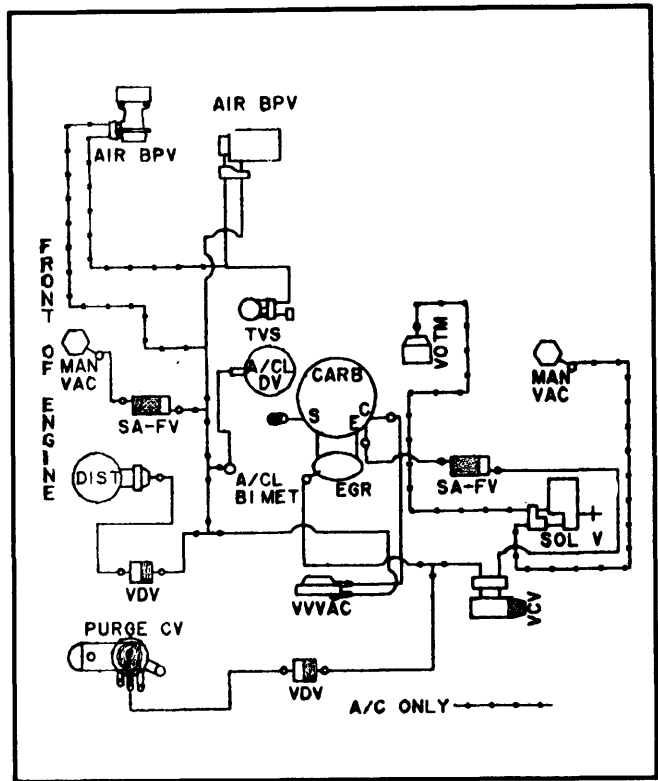

Fig. 10 Calibration 9-2B-R0; 2.3L; Federal

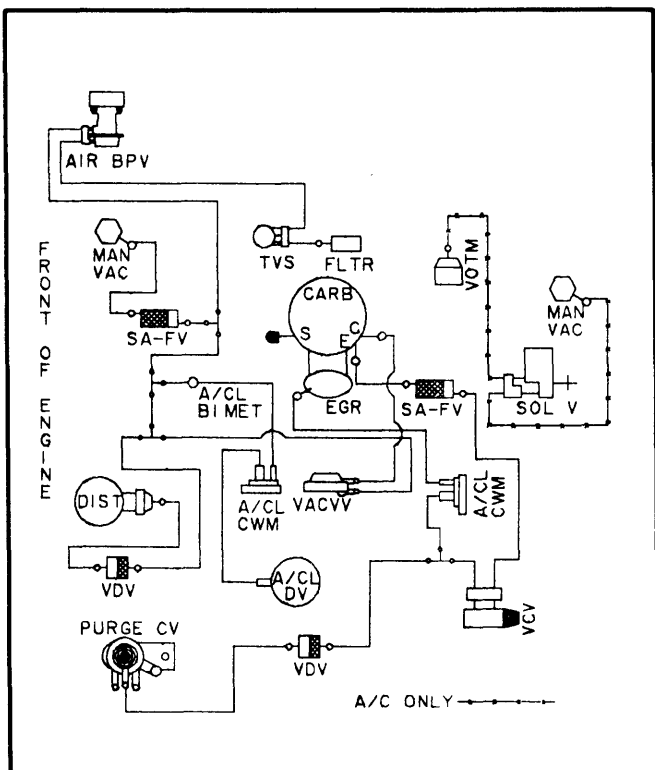

Fig. 11 Calibration 9-2B-R10; 2.3L; Federal

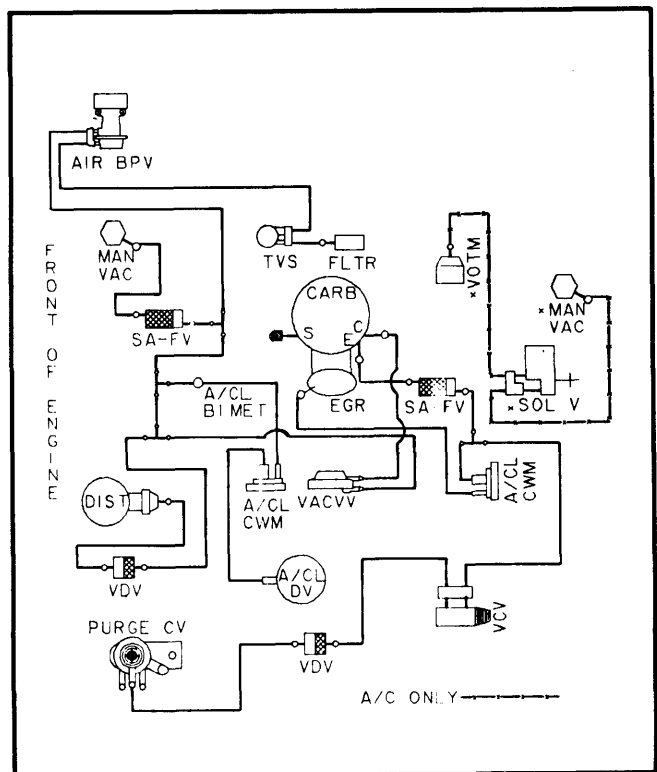

Fig. 12 Calibration 9-2B-R13; 2.3L; Federal

1979 EXHAUST EMISSION SYSTEMS Ford Motor Co. Vacuum Diagrams (Cont.)

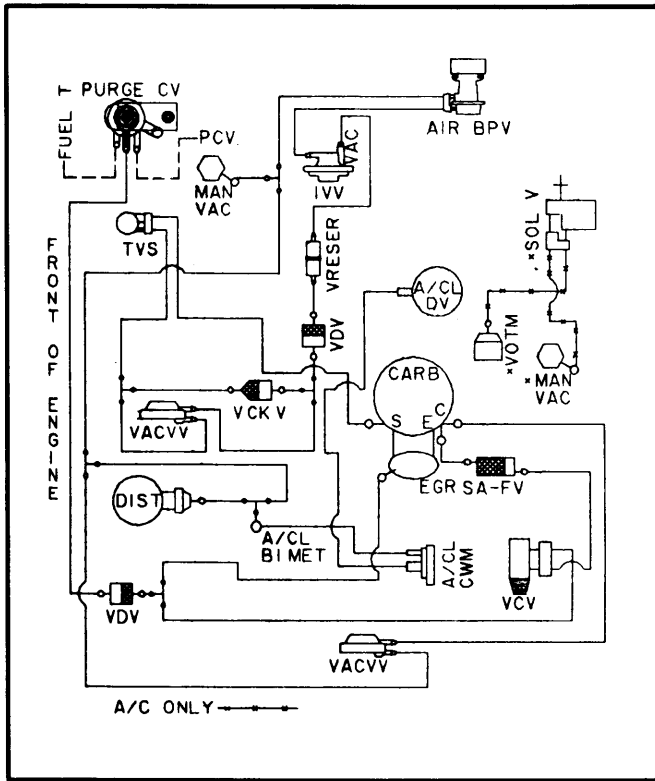

Fig. 13 Calibration 9-2C-R0; 2.3L; Federal

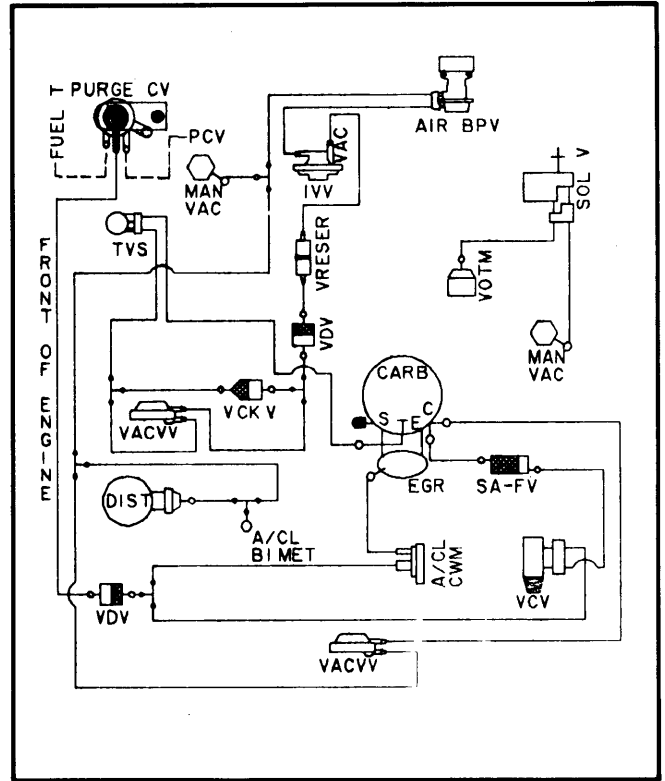

Fig. 14 Calibration 9-2C-R10; 2.3L; Federal

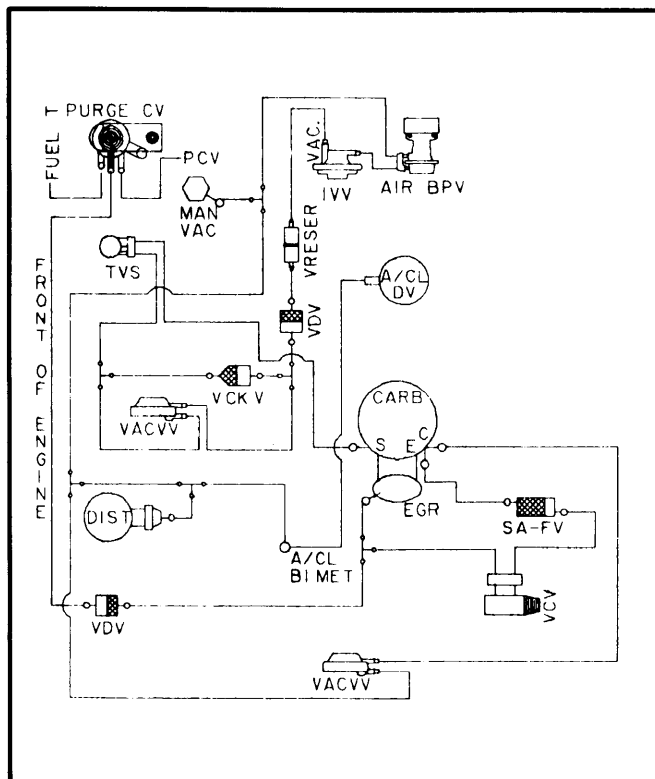

Fig. 15 Calibration 9-2D-R0; 2.3L; Federal

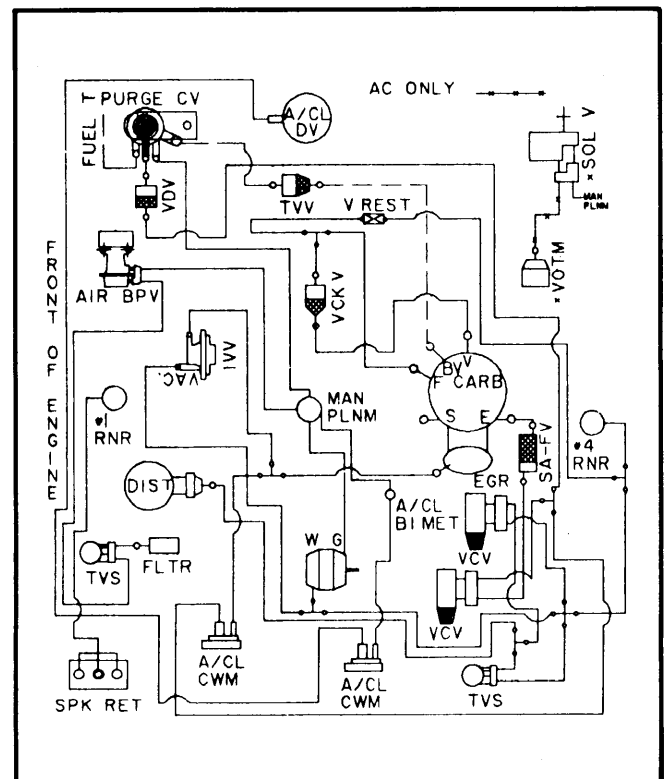

Fig. 16 Calibration 9-2E-R0 and 9-2E-R12
2.3L; Federal

1979 EXHAUST EMISSION SYSTEMS Ford Motor Co. Vacuum Diagrams (Cont.)

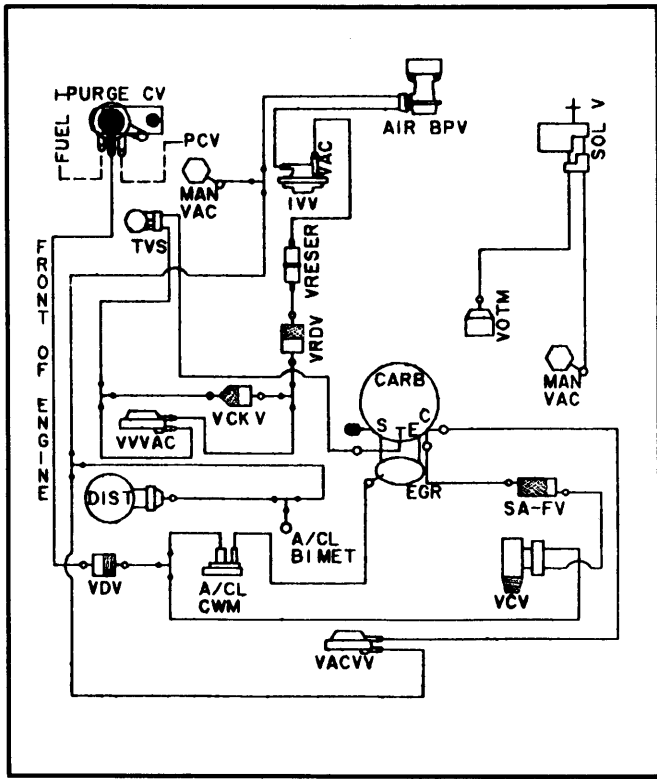

Fig. 17 Calibration 9-2F-R0; 2.3L; Federal

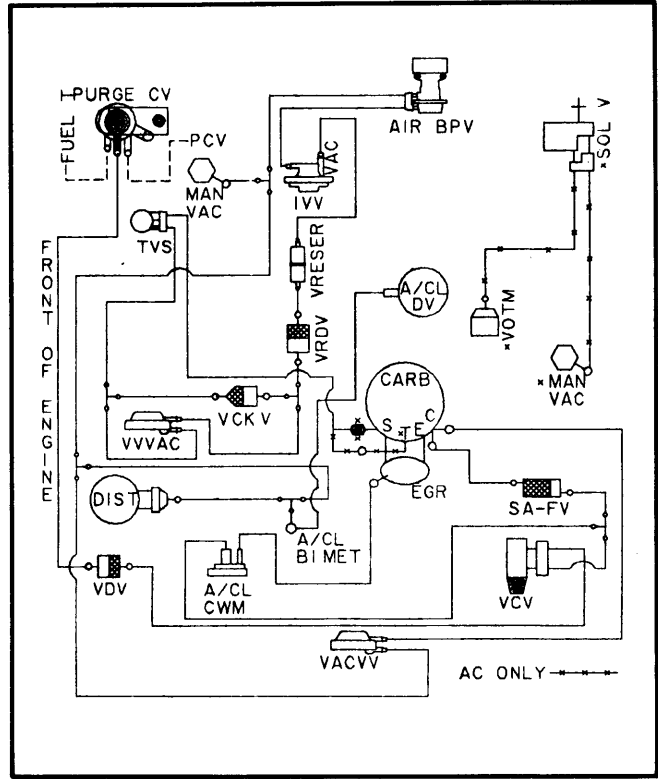

Fig. 18 Calibration 9-2F-R11; 2.3L; Federal

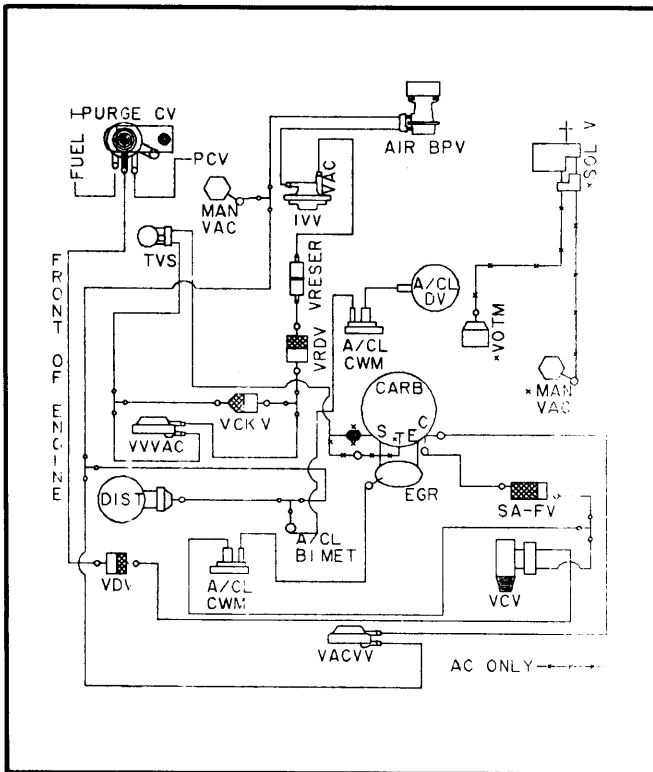

Fig. 19 Calibration 9-2F-R13; 2.3L; Federal

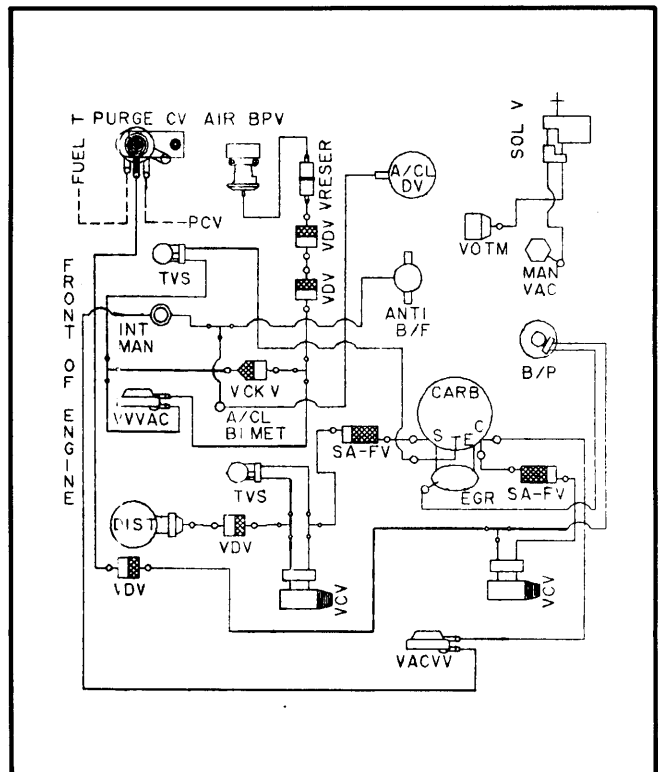

Fig. 20 Calibration 9-2N-R0; 2.3L; Calif.

1979 EXHAUST EMISSION SYSTEMS Ford Motor Co. Vacuum Diagrams (Cont.)

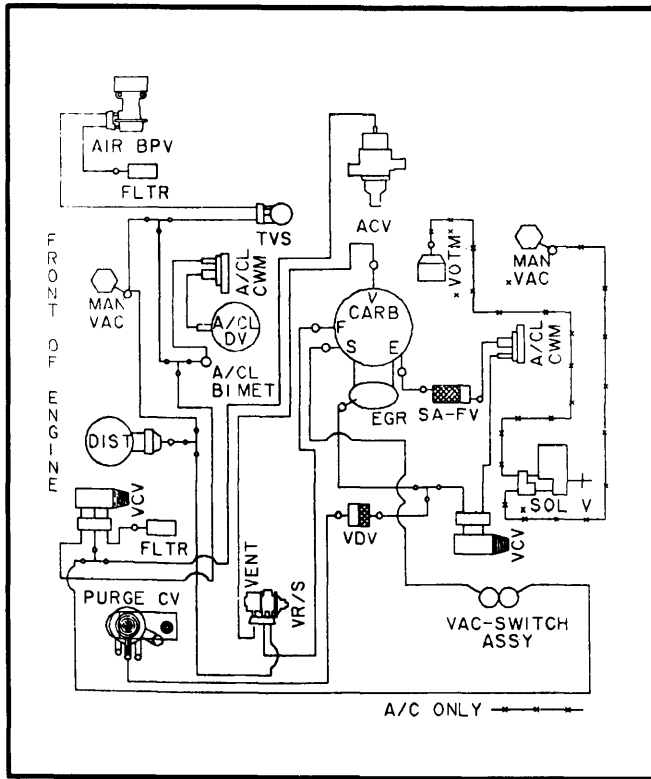

Fig. 21 Calibration 9-2P-R0; 2.3L; Calif.

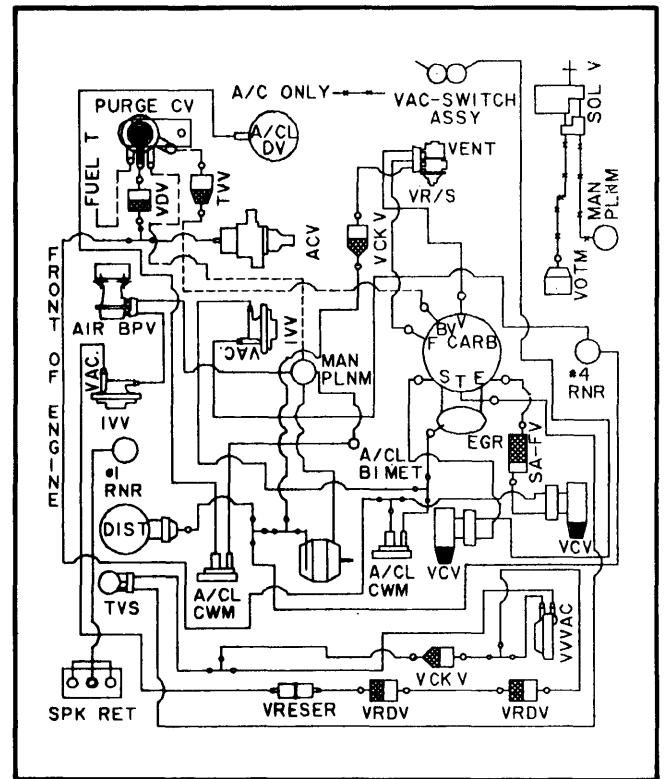

Fig. 22 Calibration 9-2R-R0; 2.3L; Calif.

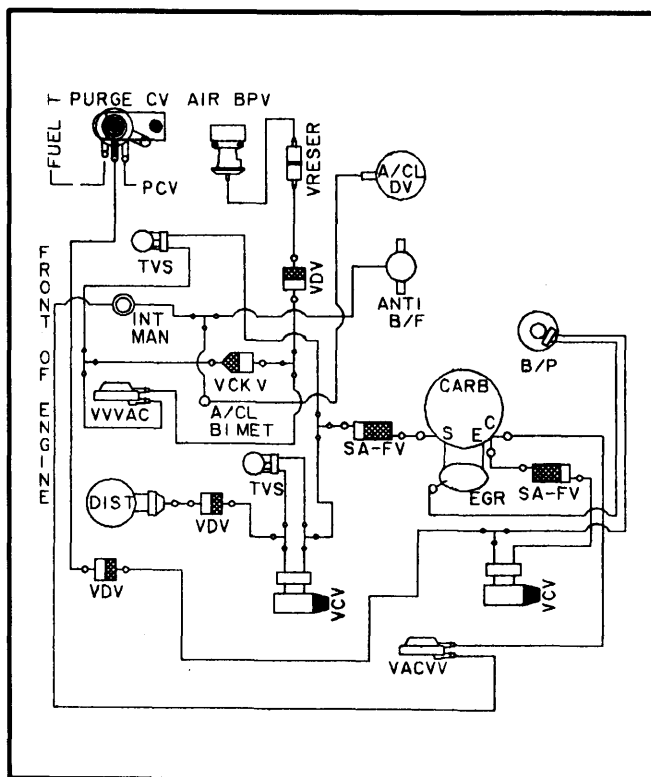

Fig. 23 Calibration 9-2S-R0 and 9-2S-R11
2.3L; Calif.

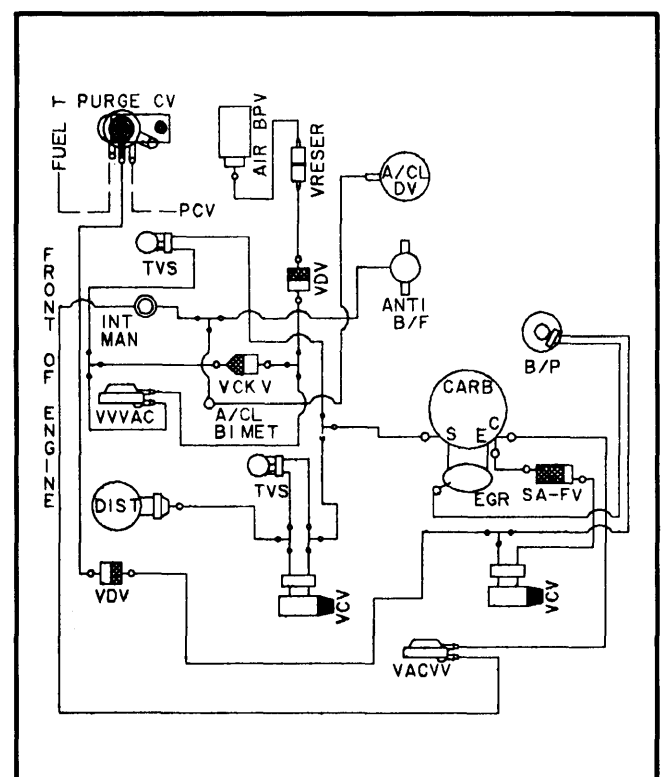

Fig. 24 Calibration 9-2S-R2; 2.3L; Calif.

1979 EXHAUST EMISSION SYSTEMS Ford Motor Co. Vacuum Diagrams (Cont.)

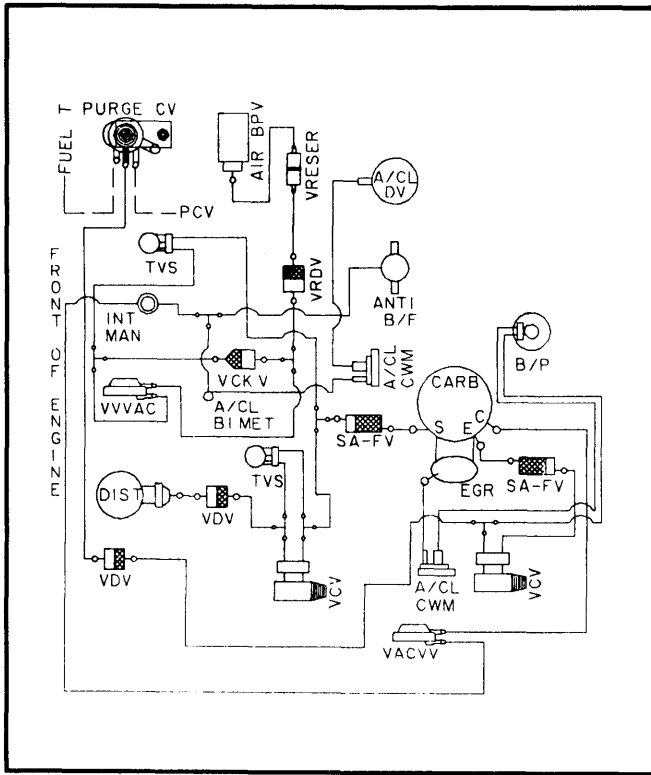

Fig. 25 Calibration 9-2S-R10 and 9-2S-R12
2.3L; Calif.

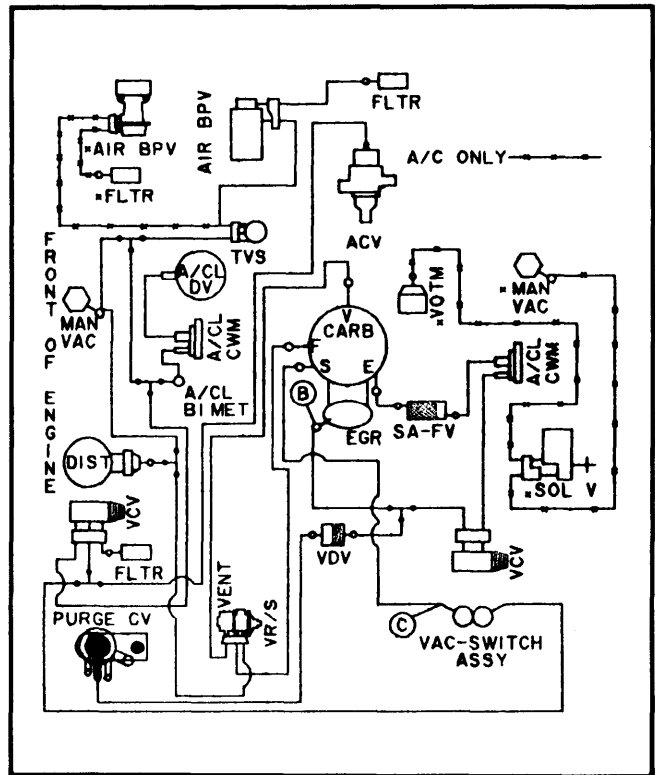

Fig. 26 Calibration 9-2T-R0; 2.3L; Calif.

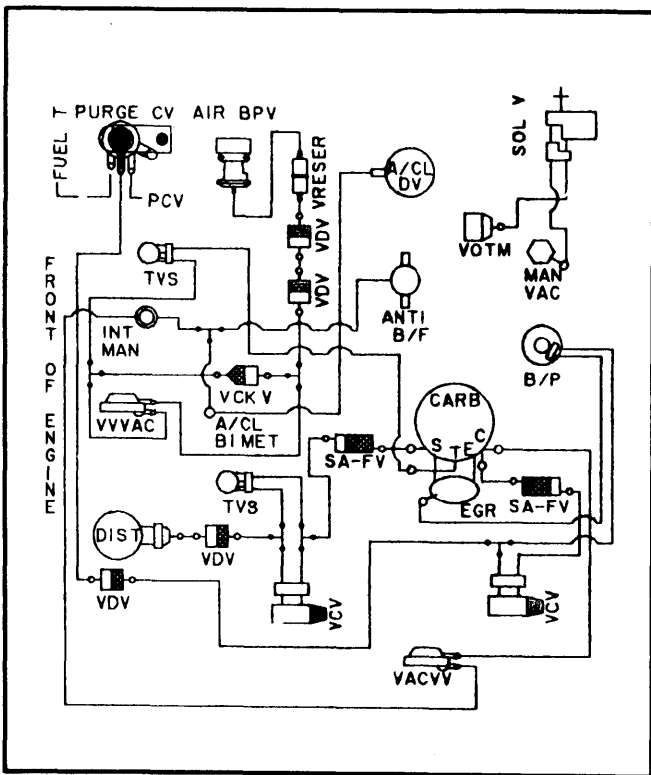

Fig. 27 Calibration 9-2V-R0; 2.3L; Calif.

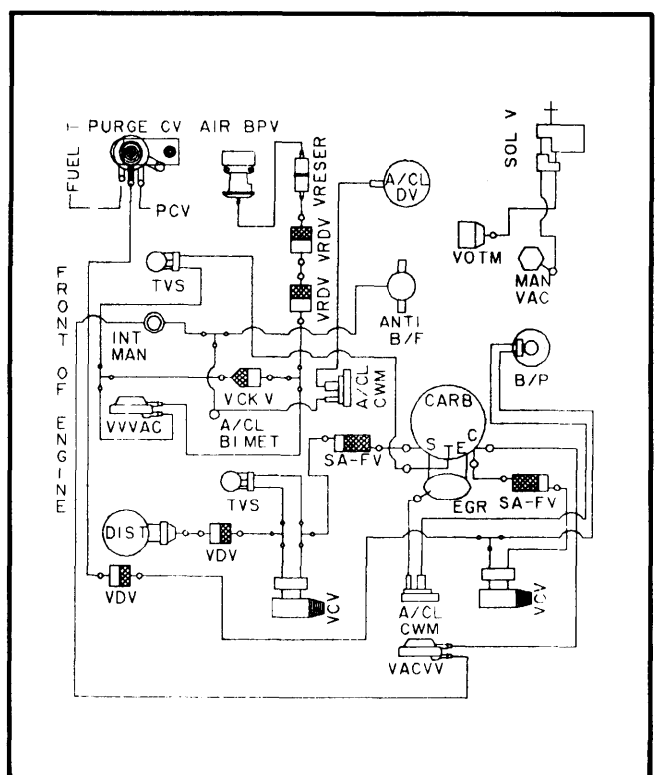

Fig. 28 Calibration 9-2V-R10 and 9-2V-R12
2.3L; Calif.

1979 EXHAUST EMISSION SYSTEMS Ford Motor Co. Vacuum Diagrams (Cont.)

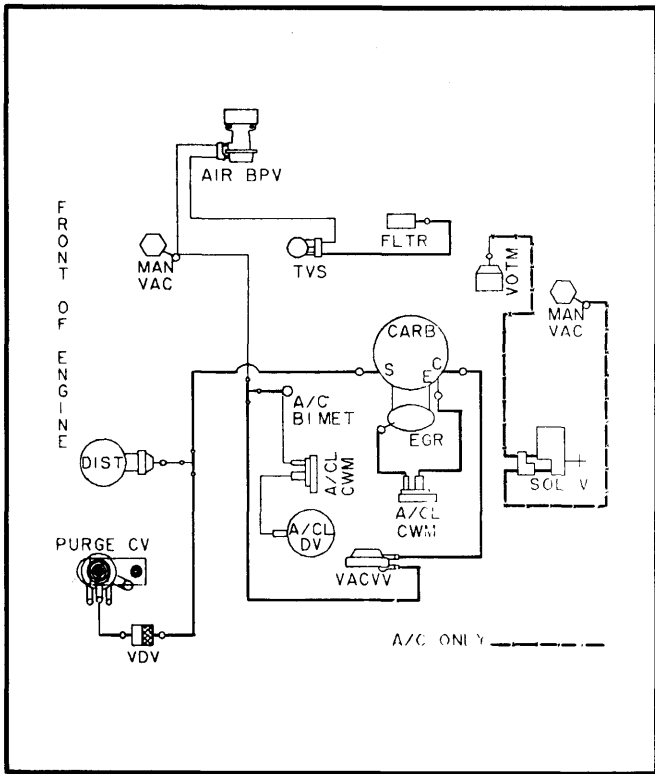

Fig. 29 Calibration 9-2X-R0; 2.3L; Federal

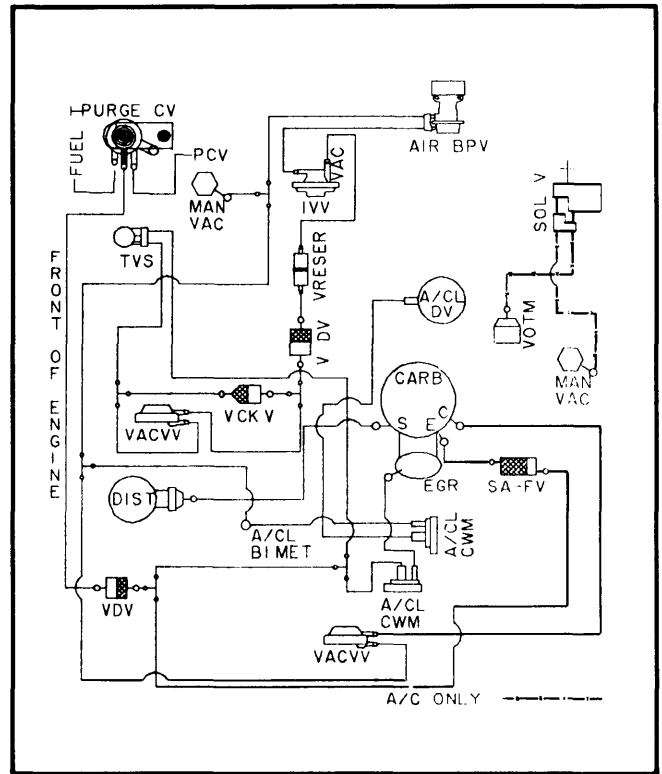

Fig. 30 Calibration 9-2Y-R0; 2.3L; Federal

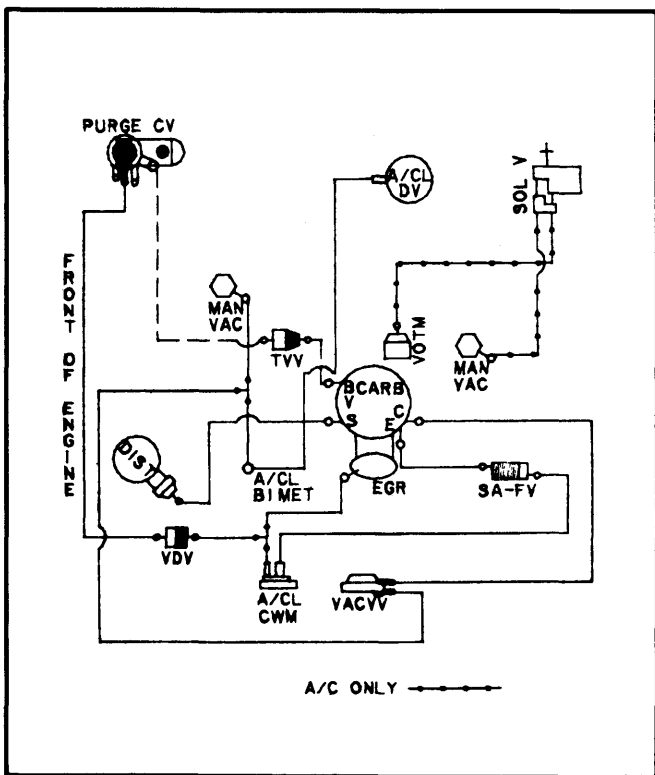

Fig. 31 Calibration 9-21B-R0; 2.3L; Federal

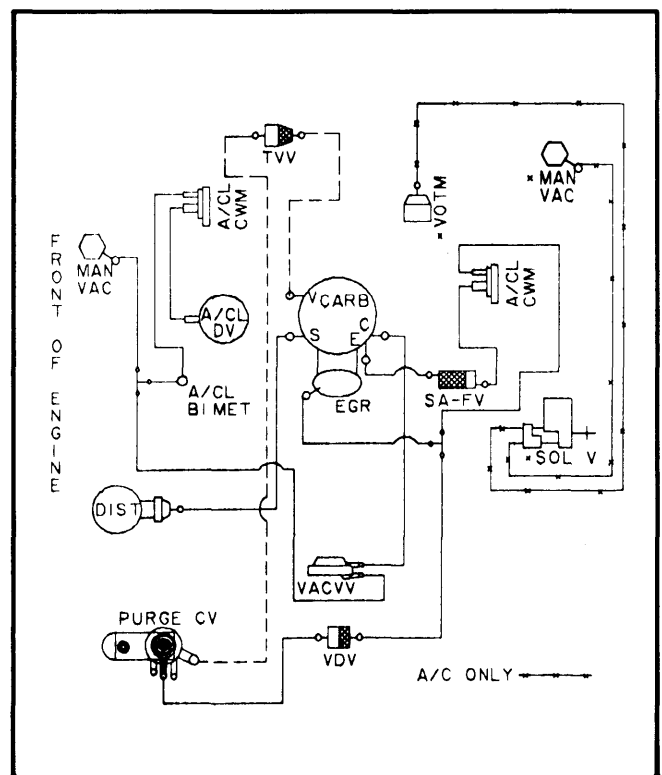

Fig. 32 Calibration 9-21B-R10; 2.3L; Federal

1979 EXHAUST EMISSION SYSTEMS Ford Motor Co. Vacuum Diagrams (Cont.)

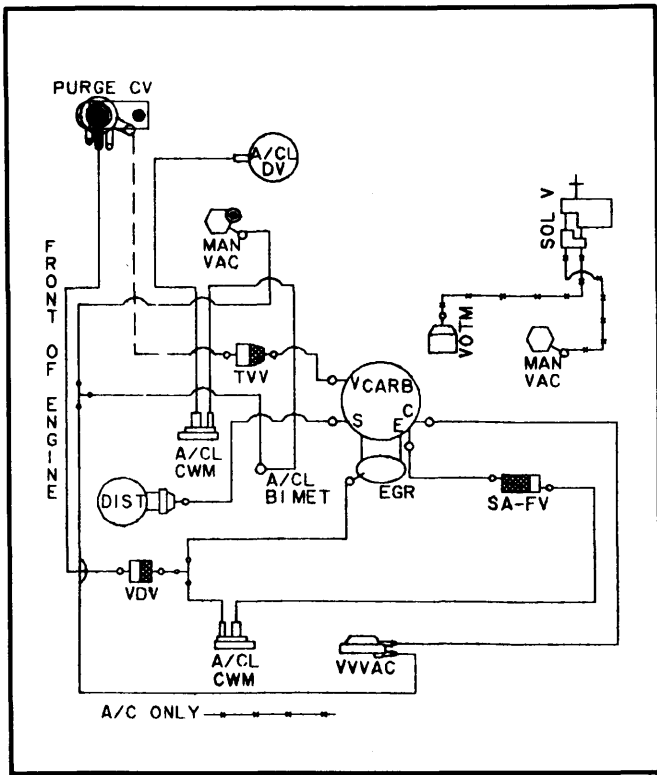

Fig. 33 Calibration 9-21C-R0; 2.3L; Federal

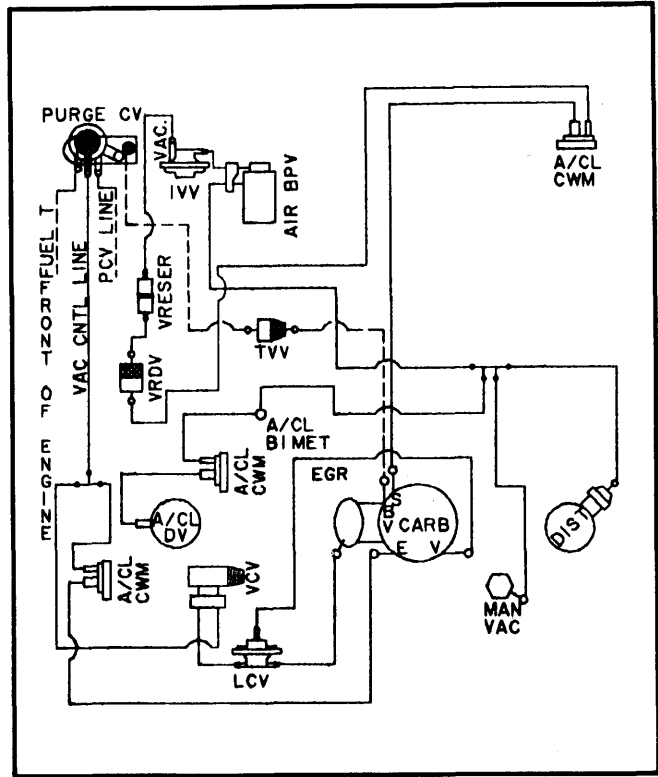

Fig. 34 Calibration 9-3A-R0; 2.8L; Federal

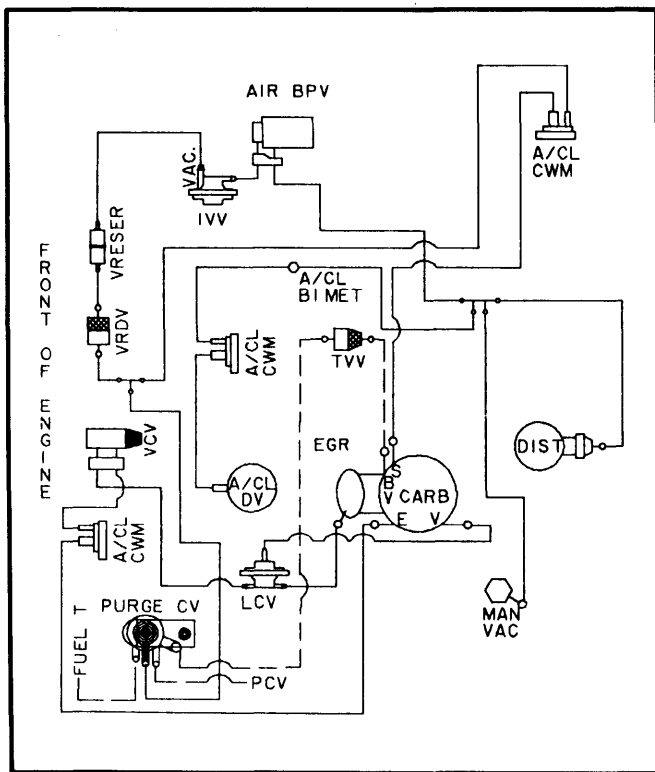

Fig. 35 Calibration 9-4A-R0 and 9-4A-R10
2.8L; Federal

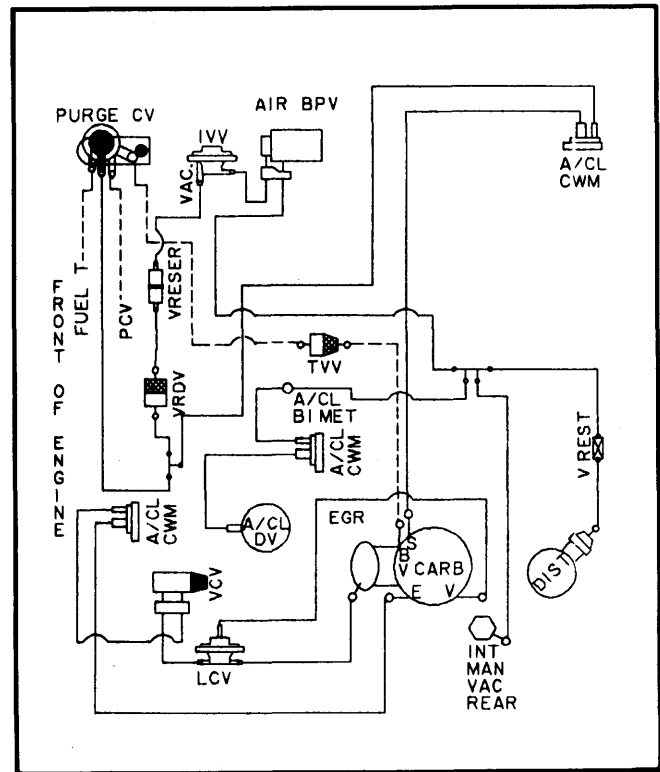

Fig. 36 Calibration 9-4A-R11 and 9-4A-R12
2.8L; Federal

1979 EXHAUST EMISSION SYSTEMS Ford Motor Co. Vacuum Diagrams (Cont.)

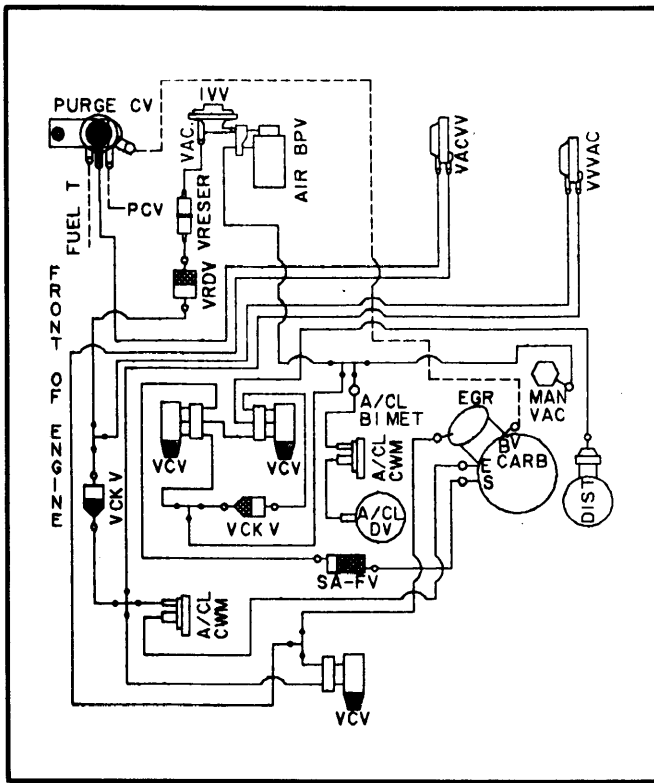

Fig. 37 Calibration 9-4N-R0; 2.8L; Calif.

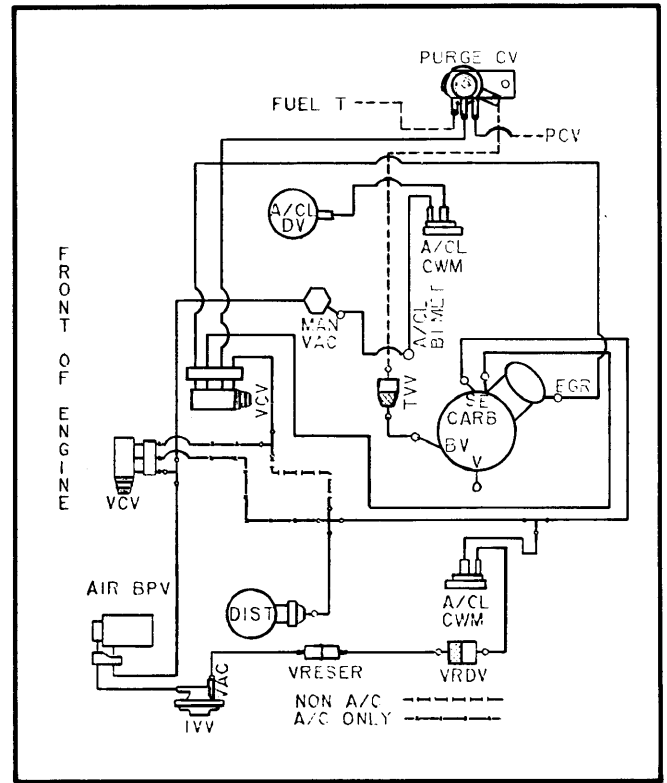

Fig. 38 Calibration 9-6A-R0; 200"; Federal

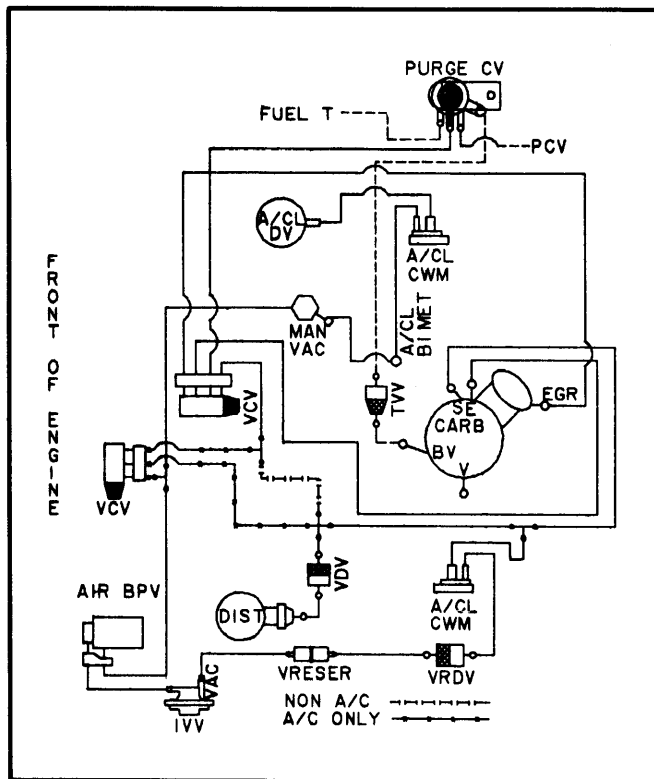

Fig. 39 Calibration 9-6A-R10; 200"; Federal

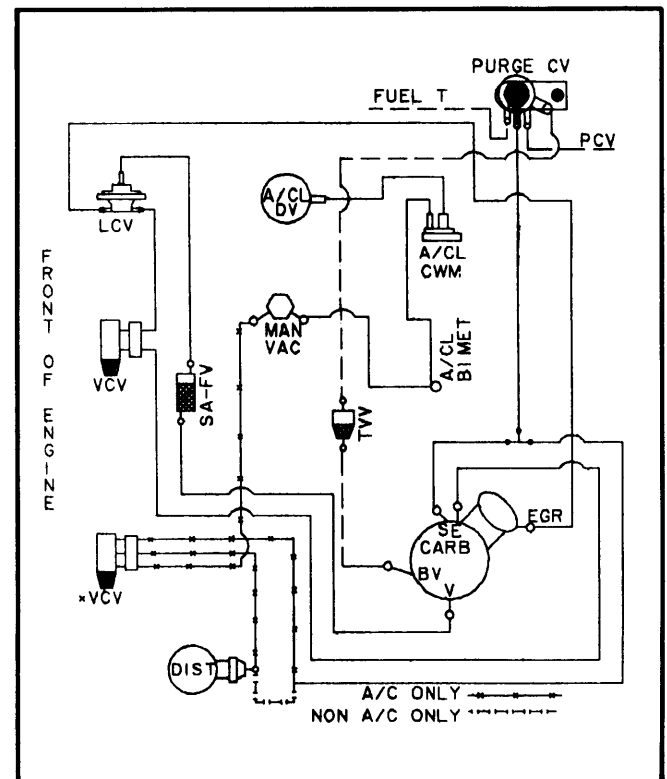

Fig. 40 Calibration 9-7A-R0; 200"; Federal

1979 EXHAUST EMISSION SYSTEMS Ford Motor Co. Vacuum Diagrams (Cont.)

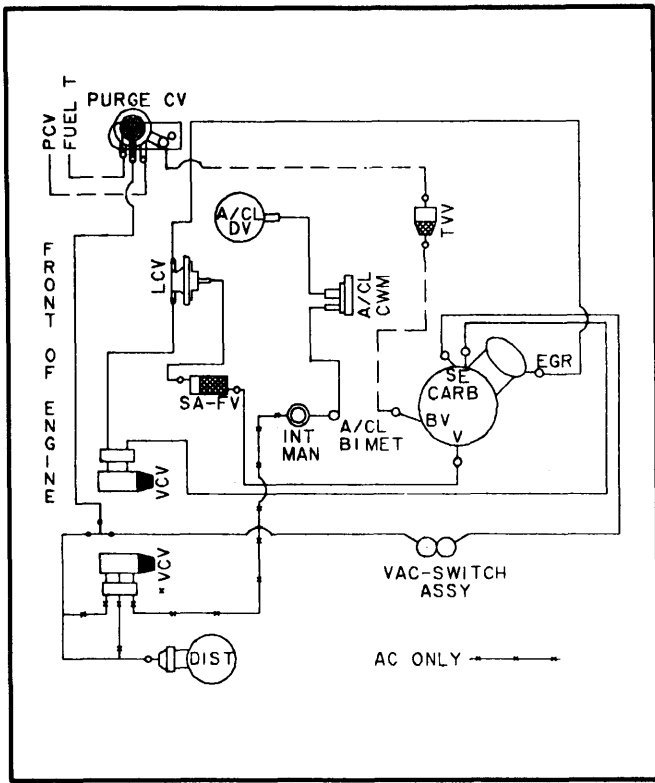

Fig. 41 Calibration 9-7A-R10; 200"; Federal

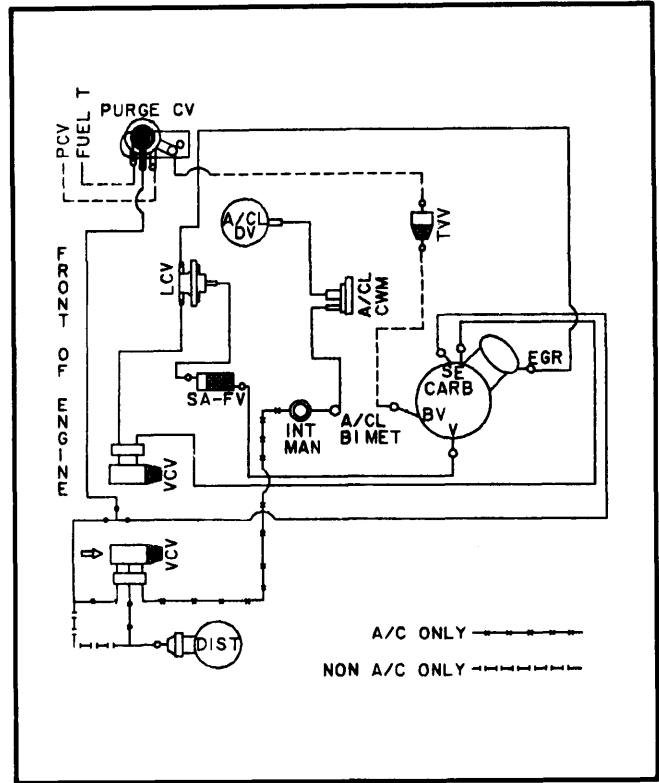

Fig. 42 Calibration 9-7A-R11, 9-7A-R12 and 9-7A-R13; 200"; Federal

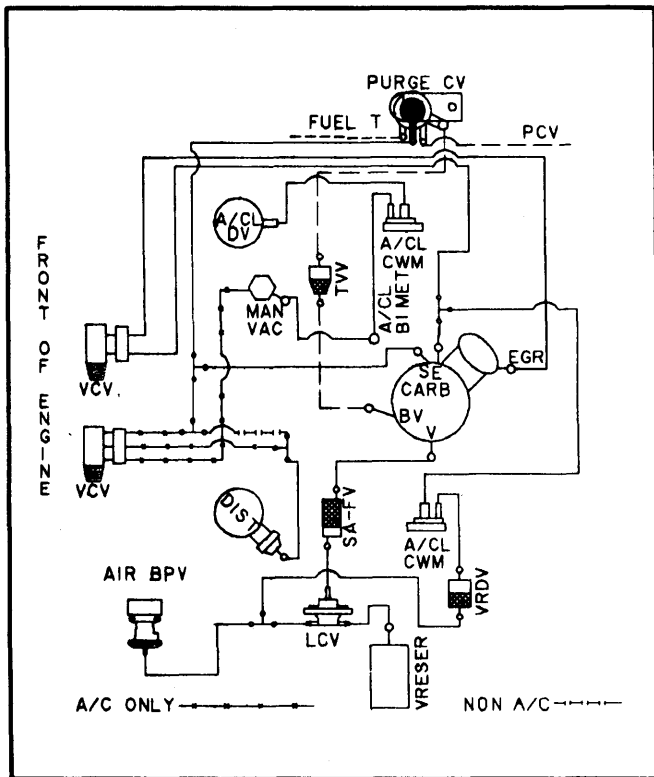

Fig. 43 Calibration 9-7D-R0; 200"; Federal

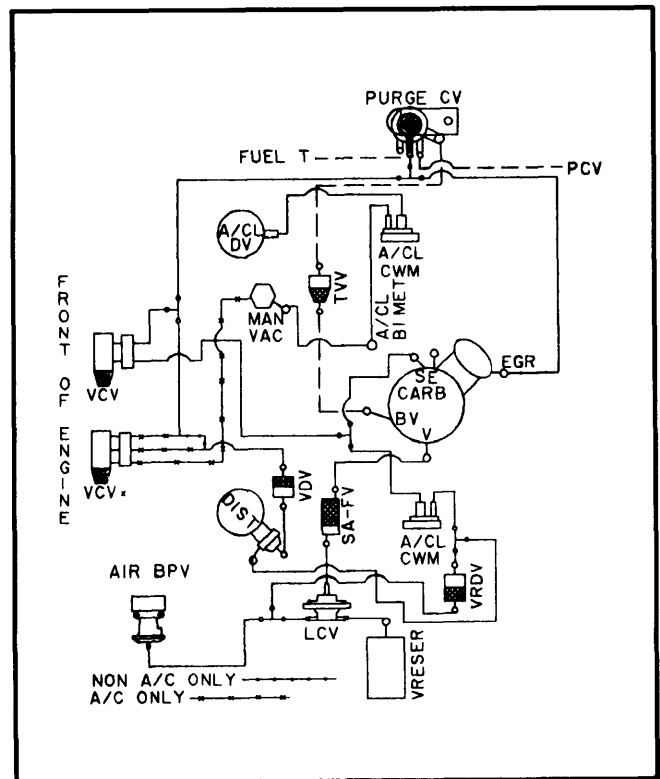

Fig. 44 Calibration 9-7N-R2 and 9-7N-R3 200"; Calif.

1979 EXHAUST EMISSION SYSTEMS Ford Motor Co. Vacuum Diagrams (Cont.)

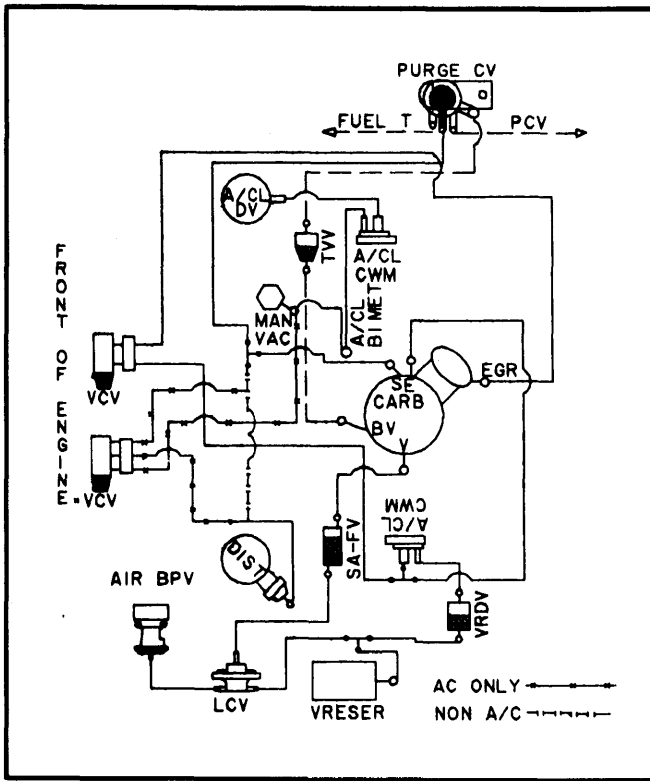

Fig. 45 Calibration 9-7Z-R10; 200"; Federal

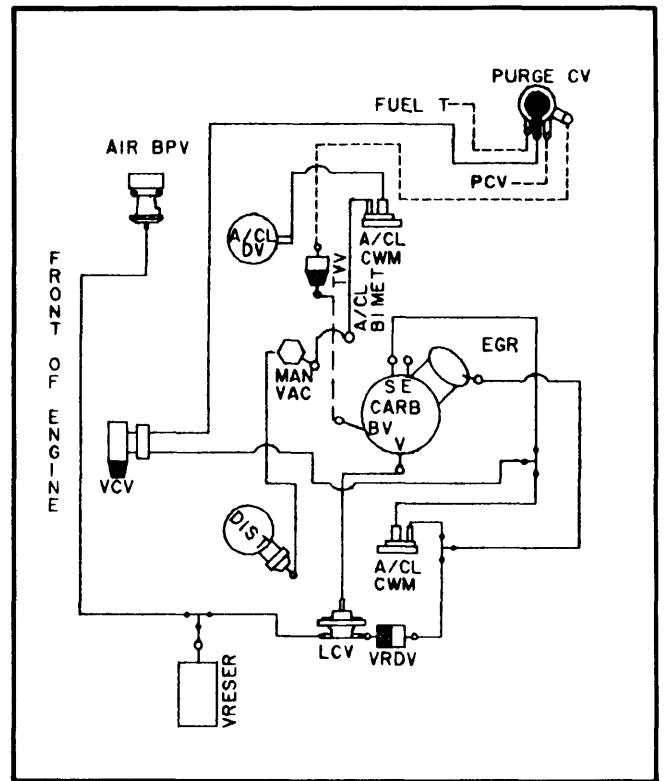

Fig. 46 Calibration 9-8A-R0 and 9-8A-R10 250"; Federal

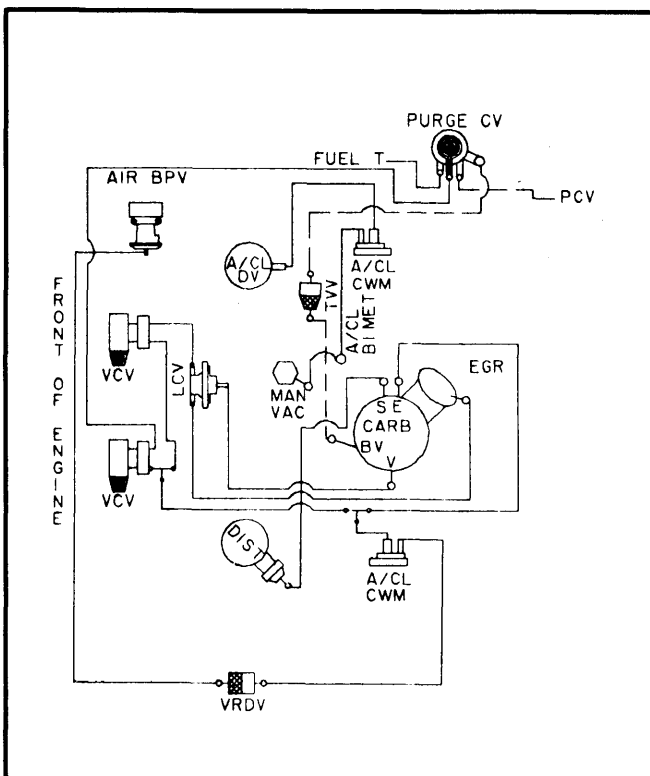

Fig. 47 Calibration 9-9A-R14 and 9-9A-R0 250"; Federal

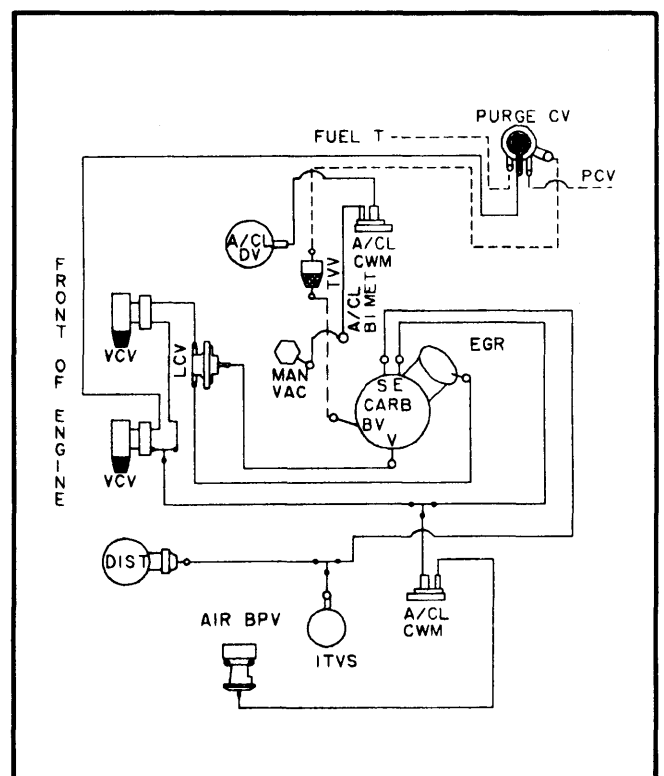

Fig. 48 Calibration 9-9A-R13; 250"; Federal

1979 EXHAUST EMISSION SYSTEMS Ford Motor Co. Vacuum Diagrams (Cont.)

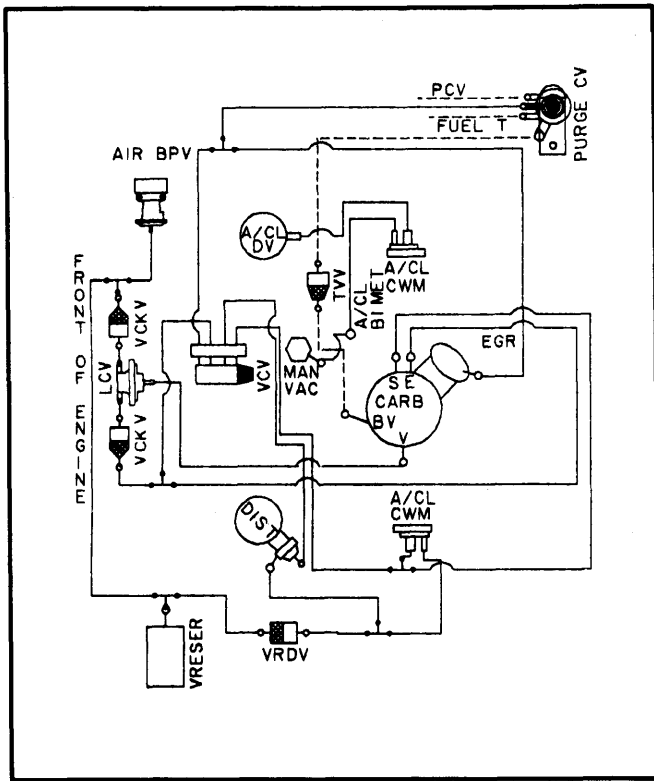

Fig. 49 Calibration 9-9P-R0, 9-9P-R10
9-9P-R11; 250"; Calif.

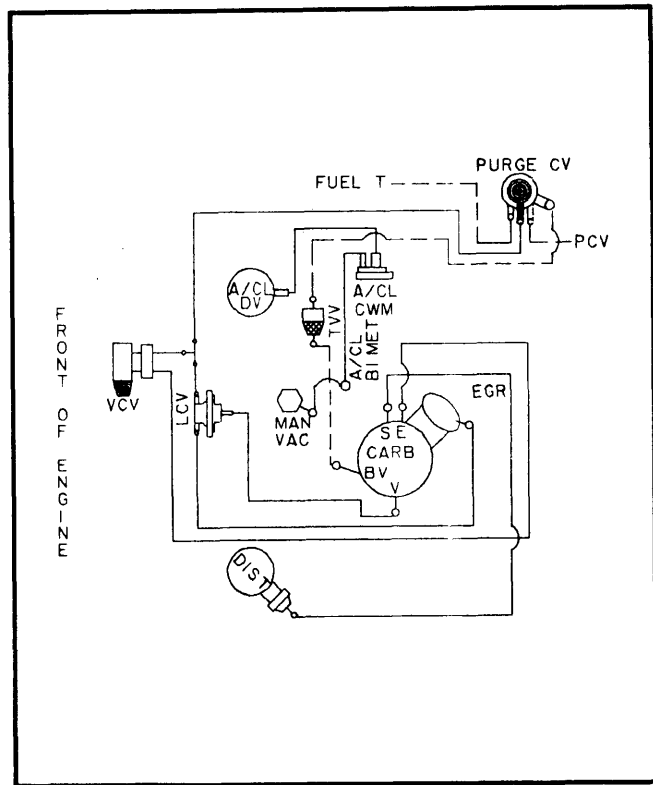

Fig. 50 Calibration 9-29B-R11; 250"; Federal

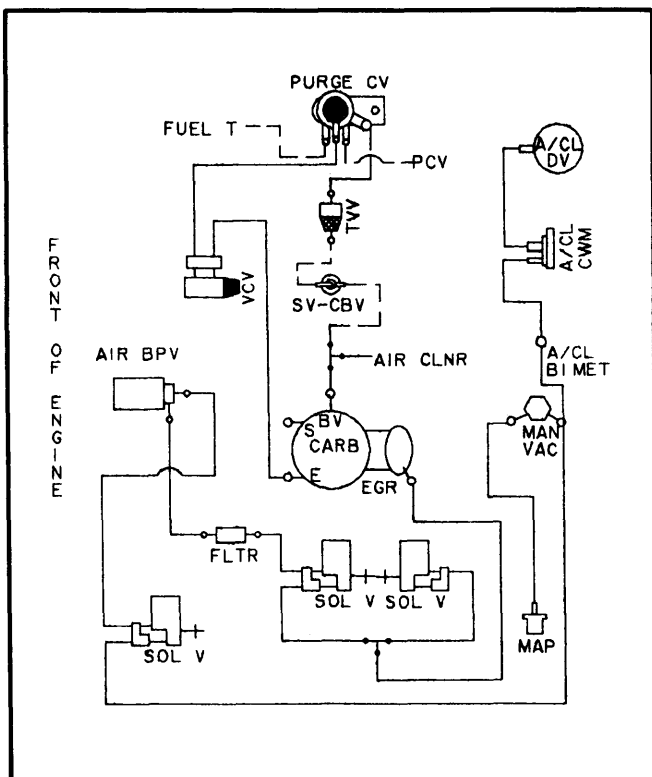

Fig. 51 Calibration 8-11D-R0; 302"; Federal

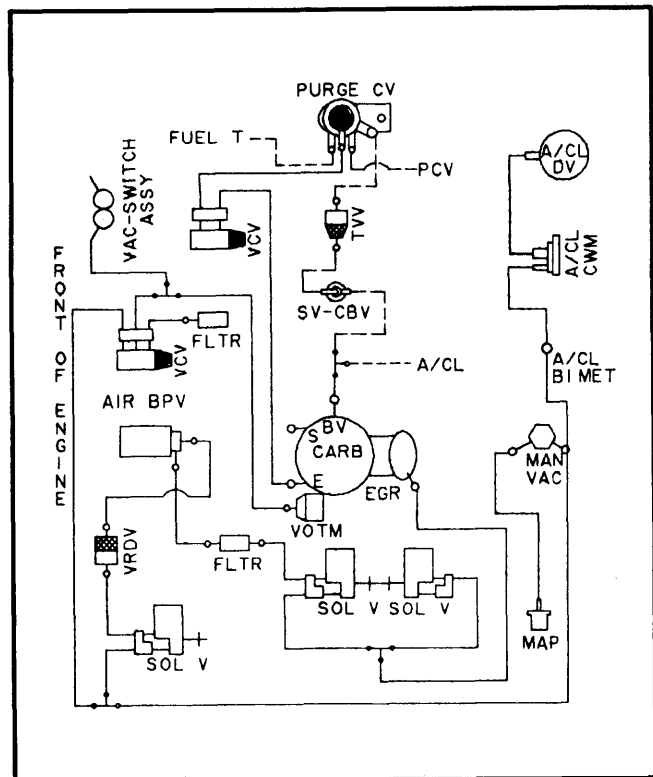

Fig. 52 Calibration 8-11L-R11; 302"; Calif.

1979 EXHAUST EMISSION SYSTEMS Ford Motor Co. Vacuum Diagrams (Cont.)

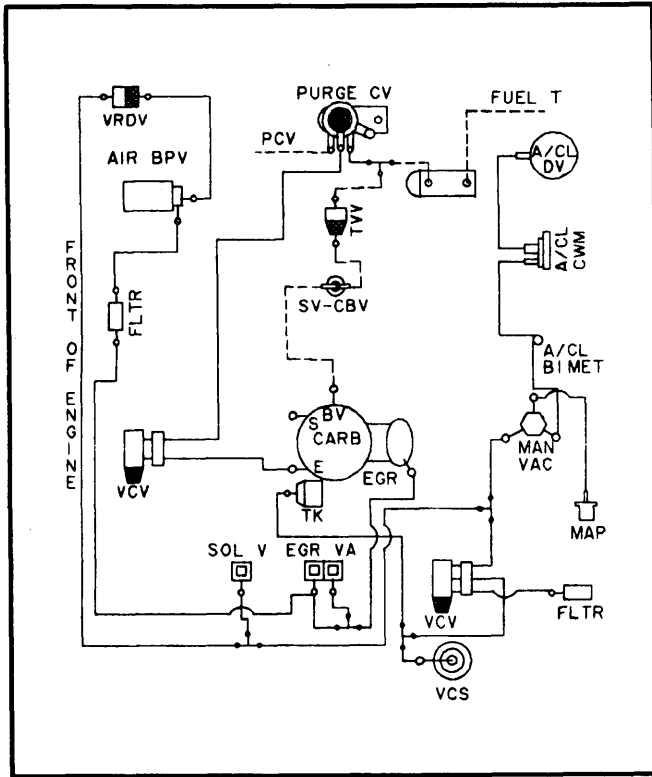

Fig. 53 Calibration 8-11L-R20; 302"; Calif.

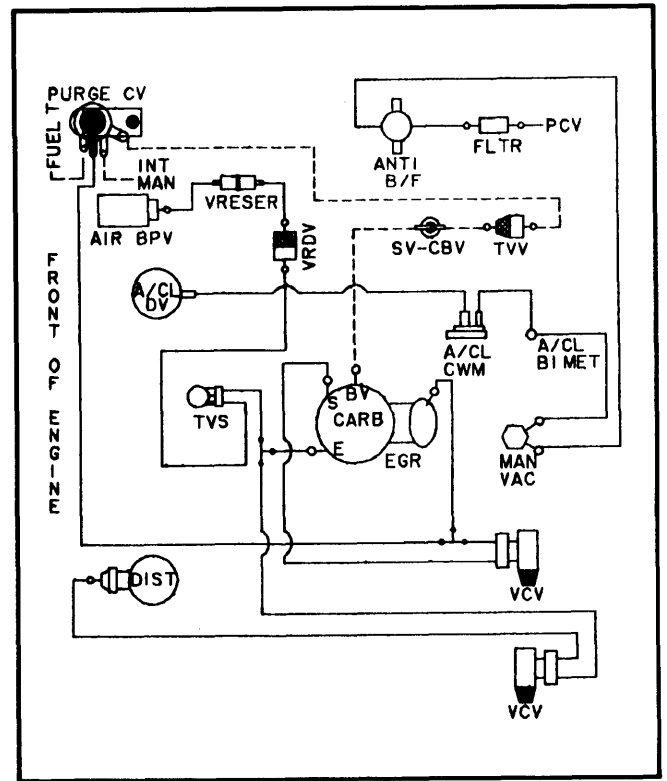

Fig. 54 Calibration 9-10A-R0; 302"; Federal

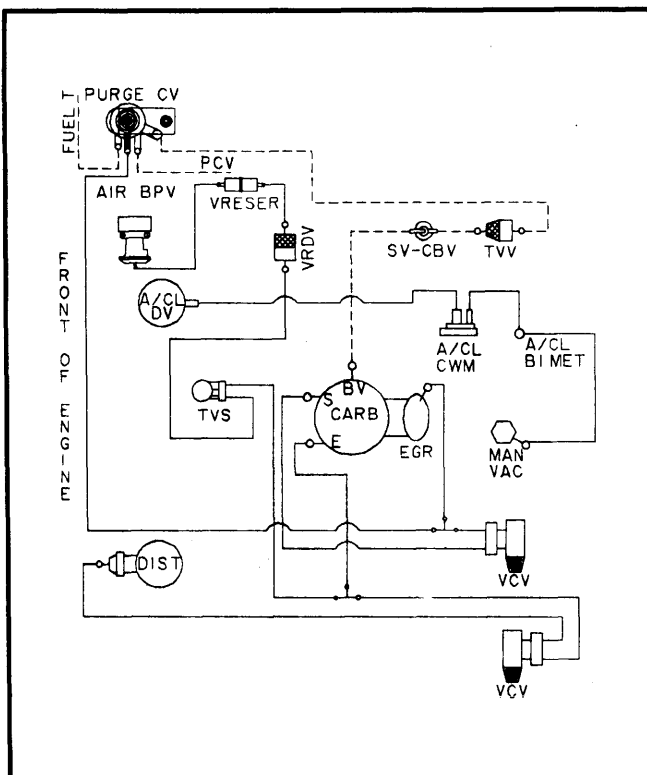

Fig. 55 Calibration 9-10B-R0; 302"; Federal

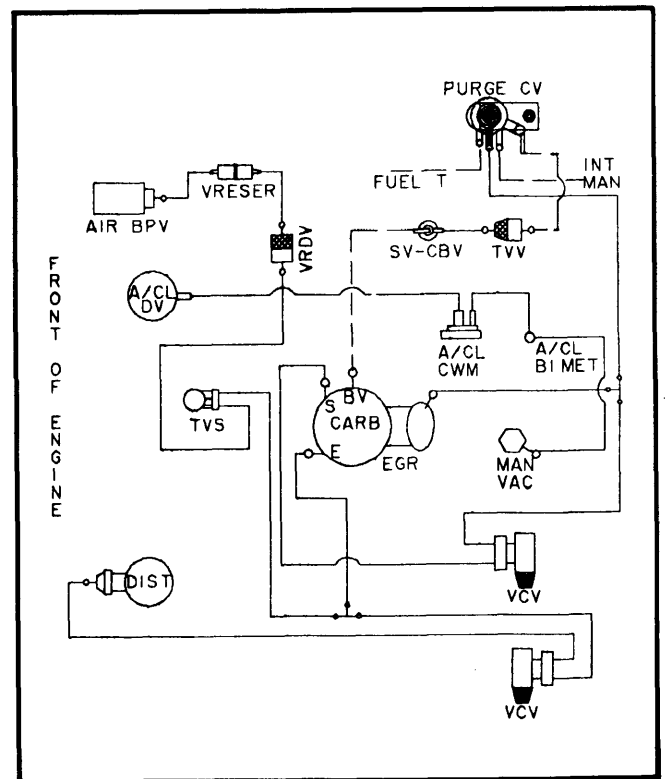
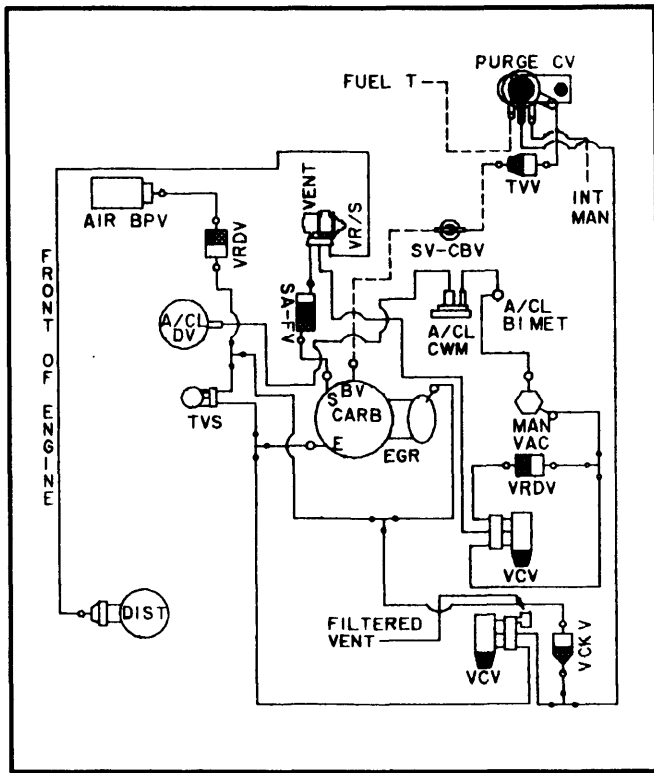

Fig. 56 Calibration 9-10C-R0 and 9-10C-R11 302"; Federal

1979 EXHAUST EMISSION SYSTEMS Ford Motor Co. Vacuum Diagrams (Cont.)



**Fig. 57 Calibration 9-11A-R0 and 9-11A-R10
302"; Federal**

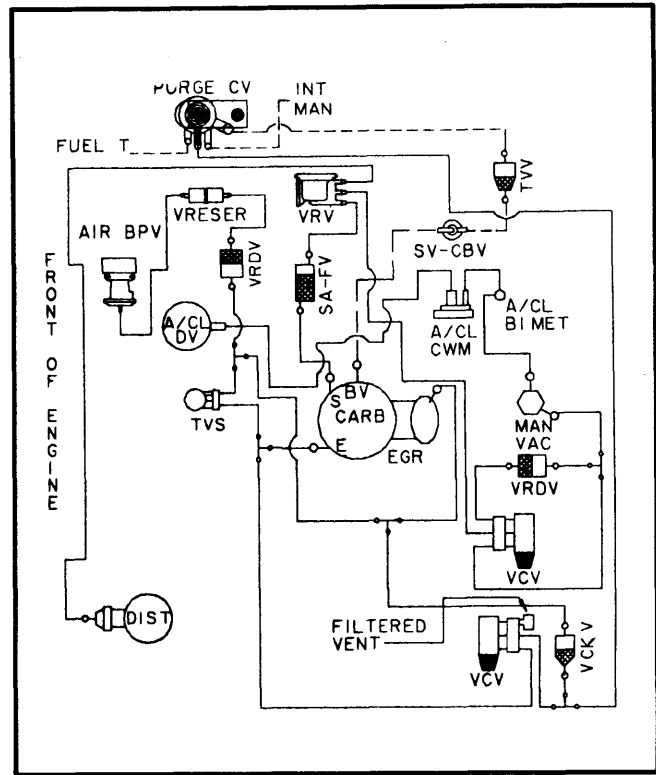

Fig. 58 Calibration 9-11A-R20; 302"; Federal

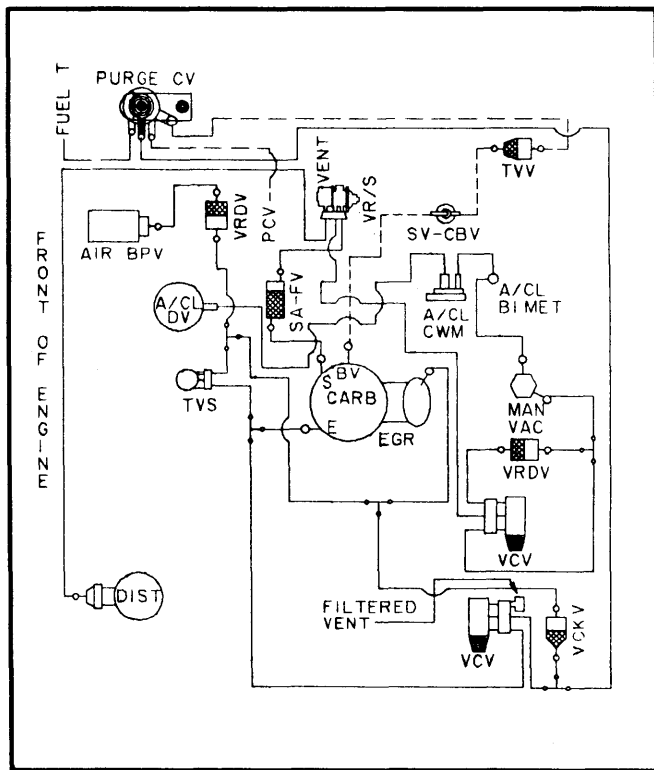

Fig. 59 Calibration 9-11B-R0; 302"; Federal

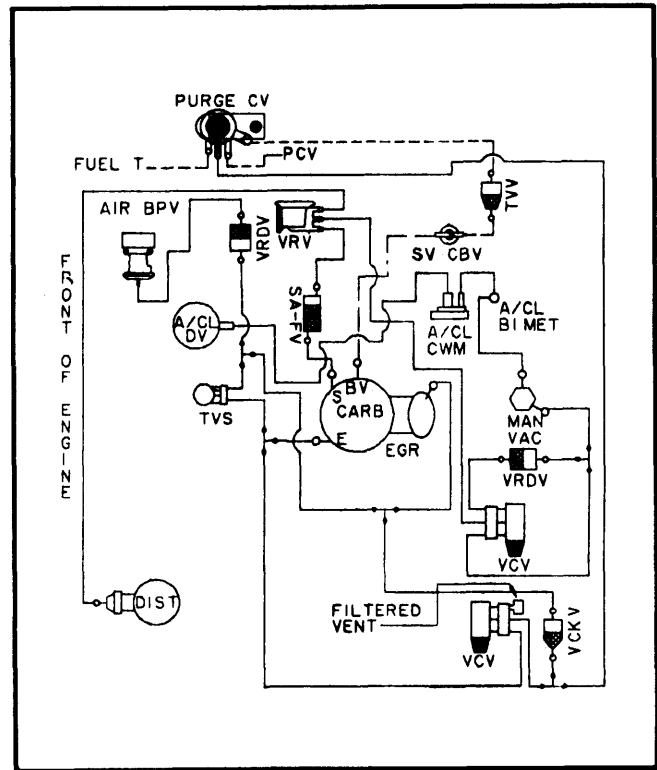

Fig. 60 Calibration 9-11B-R10; 302"; Federal

1979 EXHAUST EMISSION SYSTEMS Ford Motor Co. Vacuum Diagrams (Cont.)

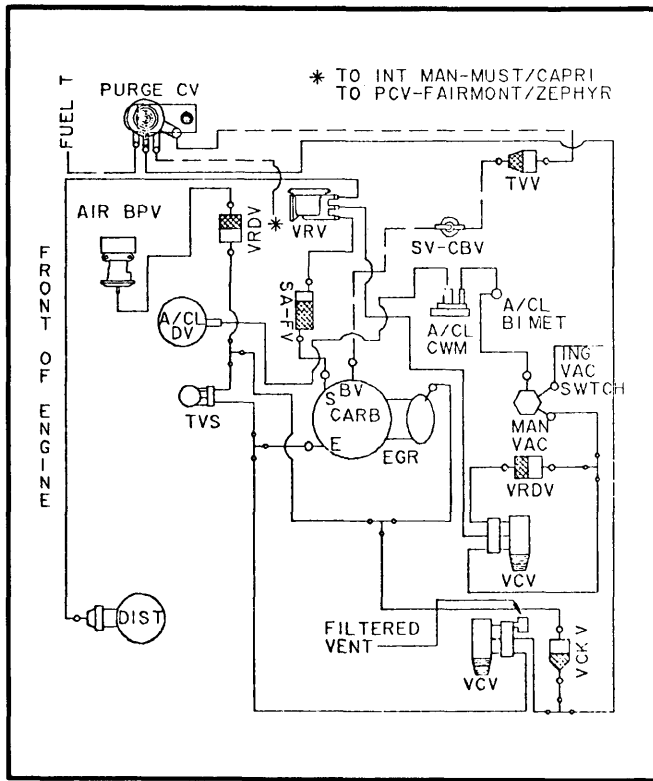

Fig. 61 Calibration 9-11B-R11; 302"; Federal

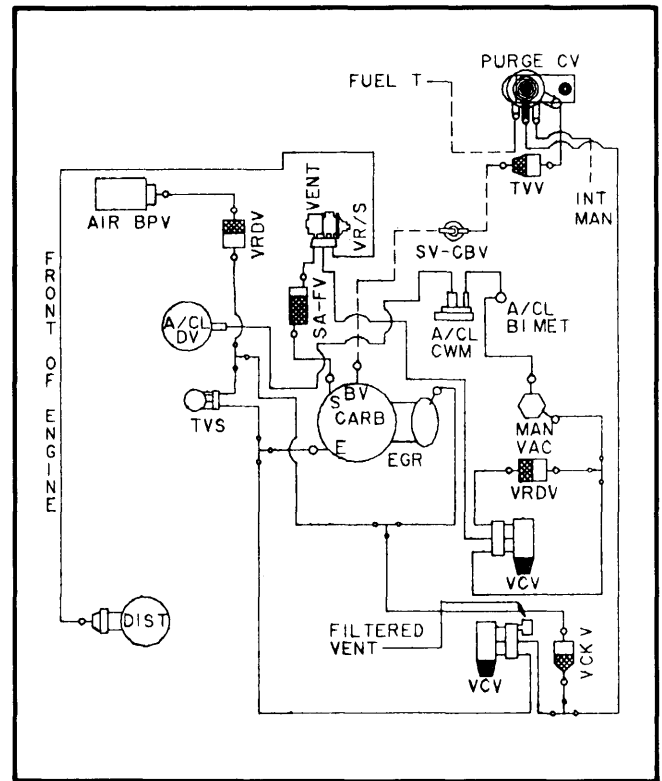

Fig. 62 Calibration 9-11C-R1 and 9-11C-R10 302"; Federal

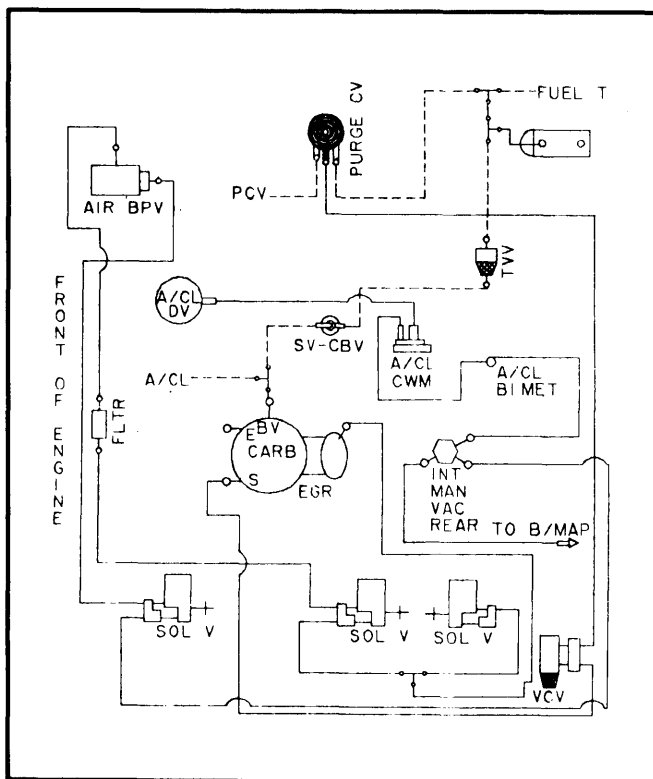

Fig. 63 Calibration 9-11D-R11; 302"; Federal

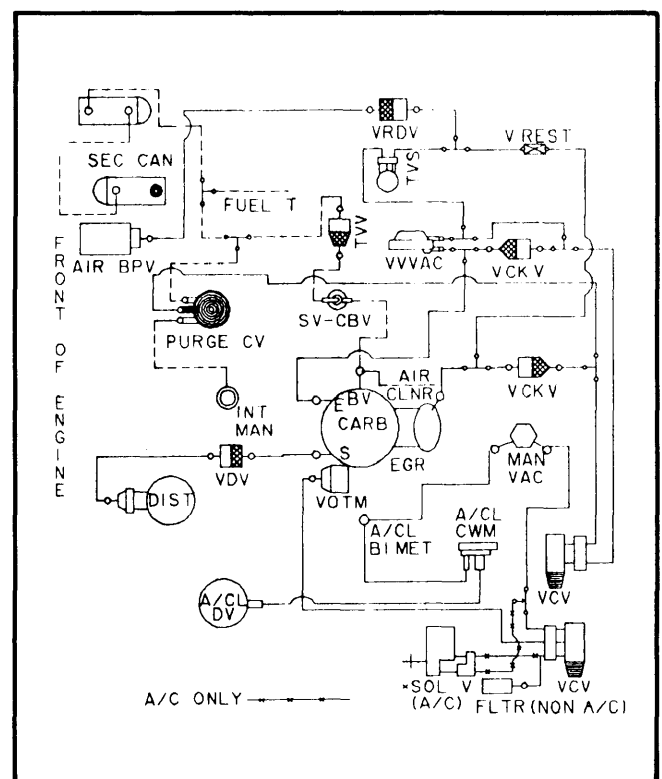

Fig. 64 Calibration 9-11E-R1; 302"; Calif.

1979 EXHAUST EMISSION SYSTEMS Ford Motor Co. Vacuum Diagrams (Cont.)

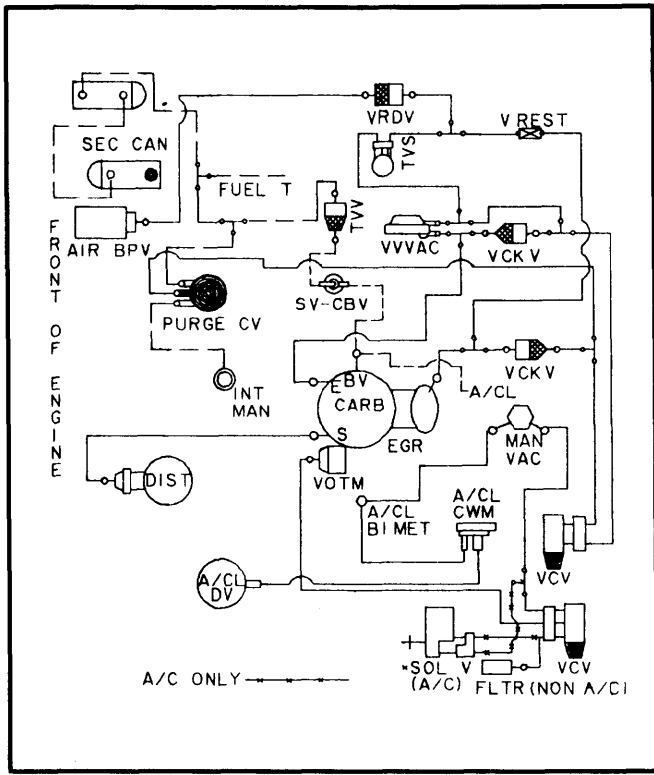

Fig. 65 Calibration 9-11E-R10; 302"; Calif.

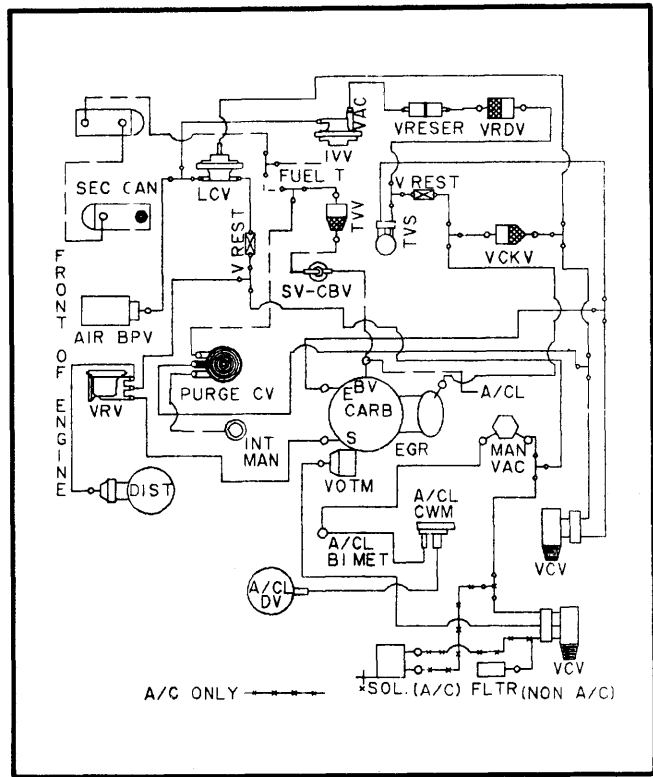

Fig. 66 Calibration 9-11E-R13; 302"; Federal

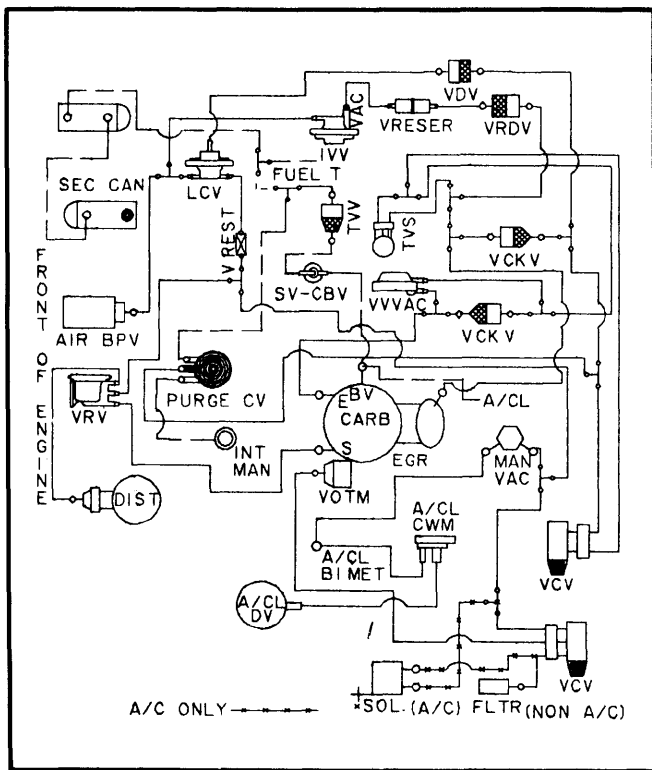

Fig. 67 Calibration 9-11F-R1; 302"; Federal

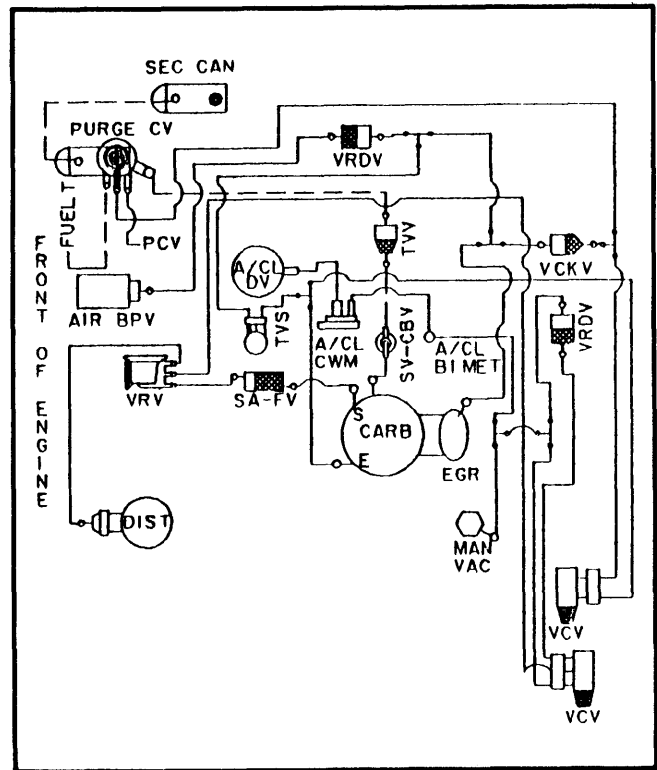

Fig. 68 Calibration 9-11J-R10 and 9-11J-R13
302"; Federal

1979 EXHAUST EMISSION SYSTEMS Ford Motor Co. Vacuum Diagrams (Cont.)

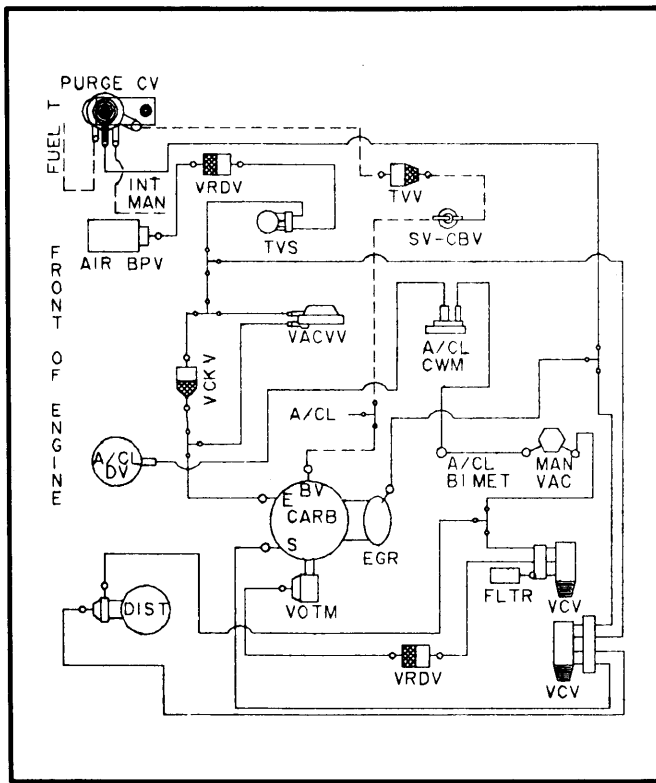

Fig. 69 Calibration 9-11N-R0; 302"; Calif.

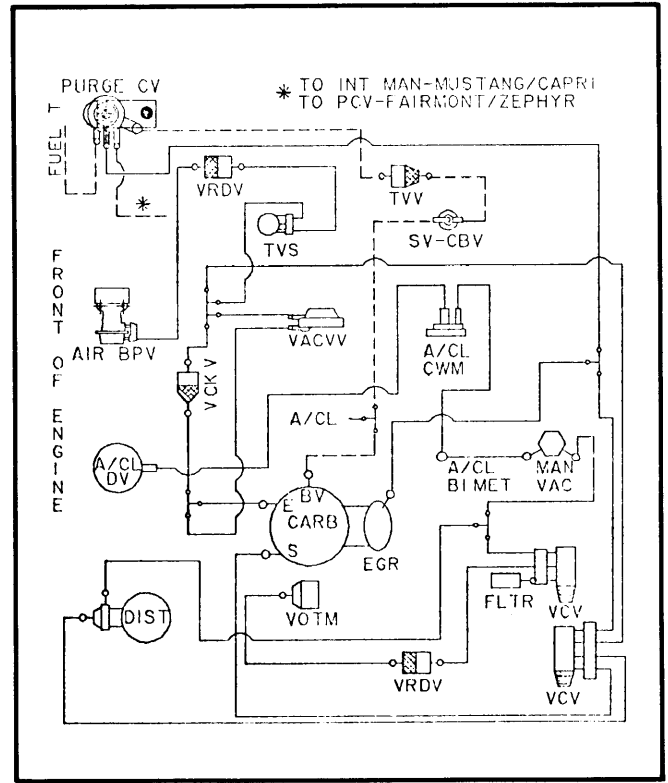

Fig. 70 Calibration 9-11N-R10; 302"; Calif.

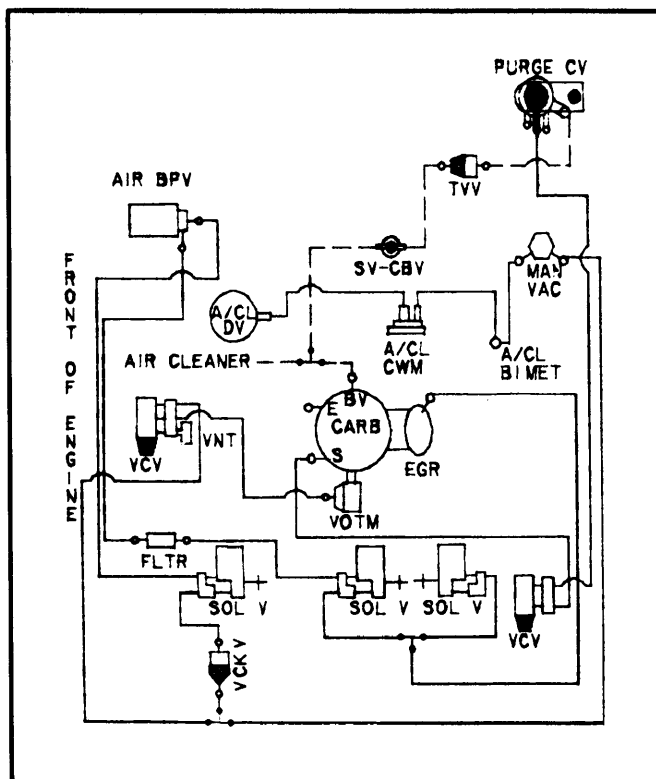

Fig. 71 Calibration 9-11P-R0; 302"; Calif.

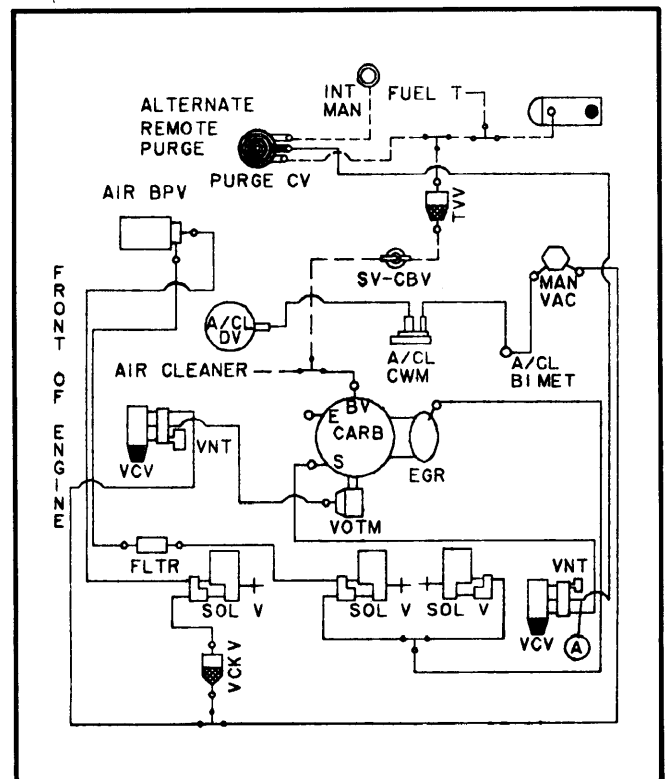

Fig. 72 Calibration 9-11P-R2; 302"; Calif.

1979 EXHAUST EMISSION SYSTEMS Ford Motor Co. Vacuum Diagrams (Cont.)

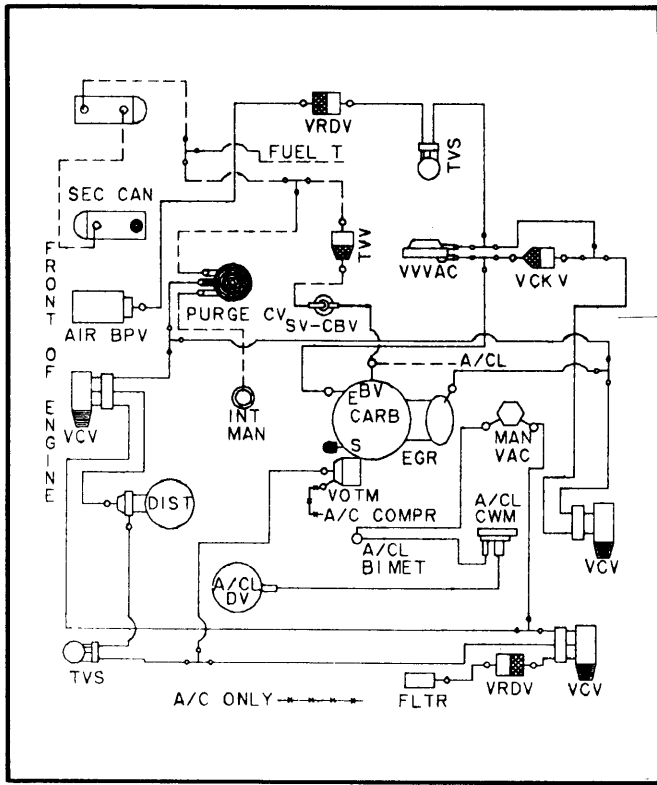

Fig. 73 Calibration 9-11Q-R1; 302"; Calif.

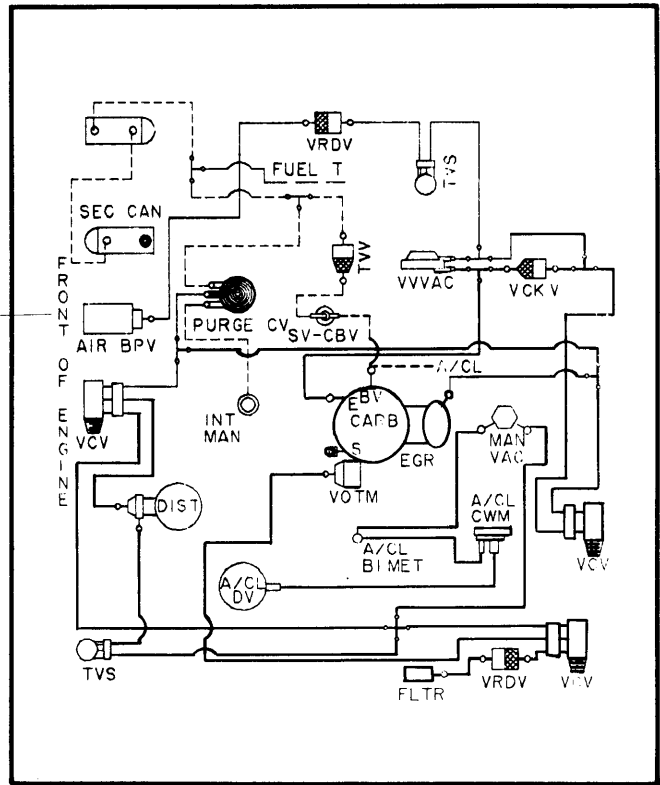

Fig. 74 Calibration 9-11Q-R15; 302"; Calif.

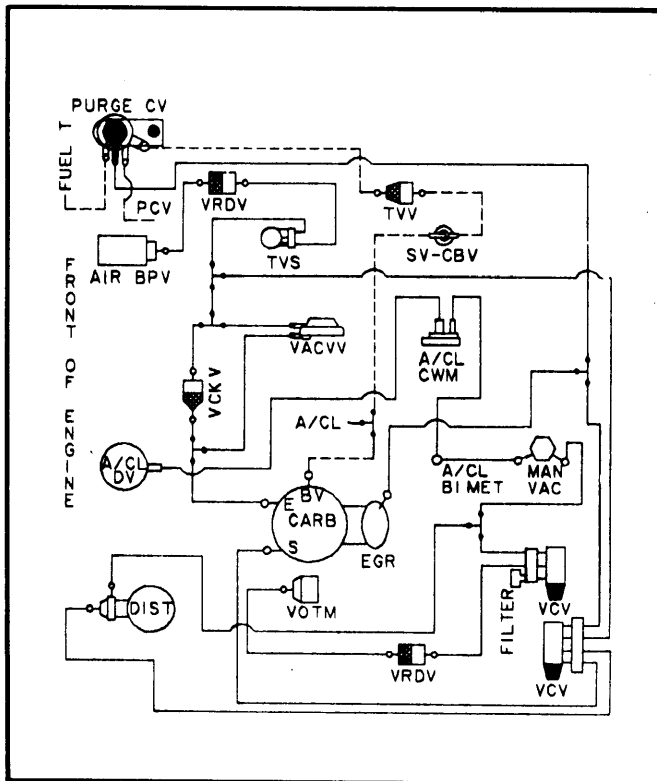

Fig. 75 Calibration 9-11R-R0 and 9-11R-R10
302"; Calif.

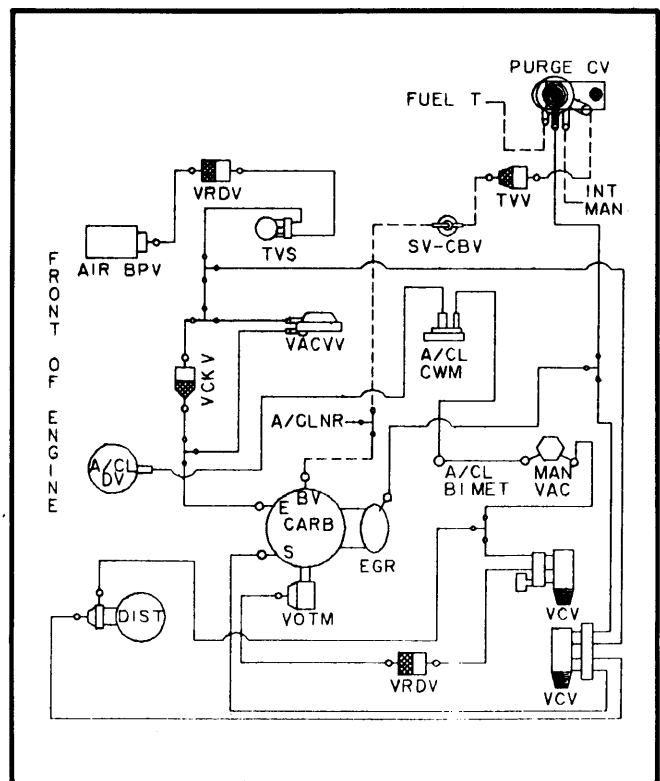

Fig. 76 Calibration 9-11S-R0; 302"; Calif.

1979 EXHAUST EMISSION SYSTEMS

Ford Motor Co. Vacuum Diagrams (Cont.)

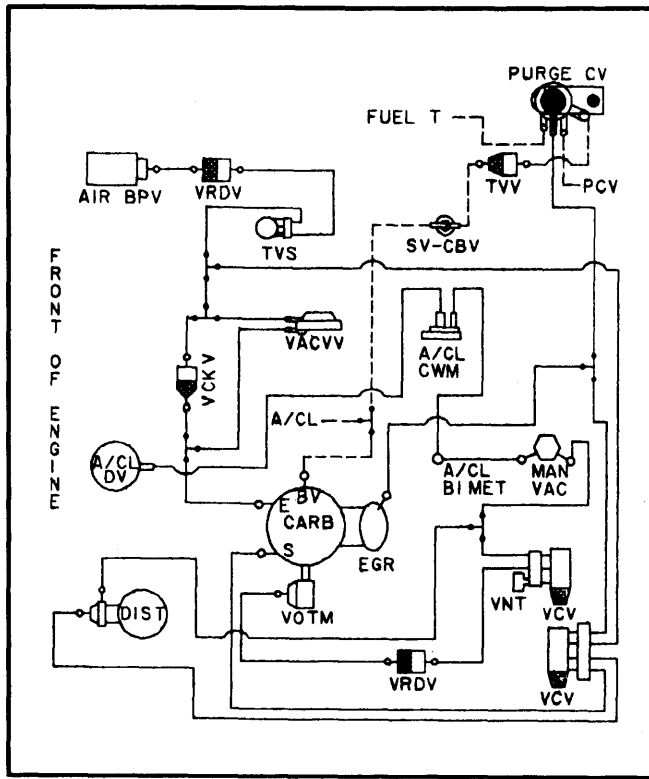

Fig. 77 Calibration 9-11V-R0; 302"; Calif.

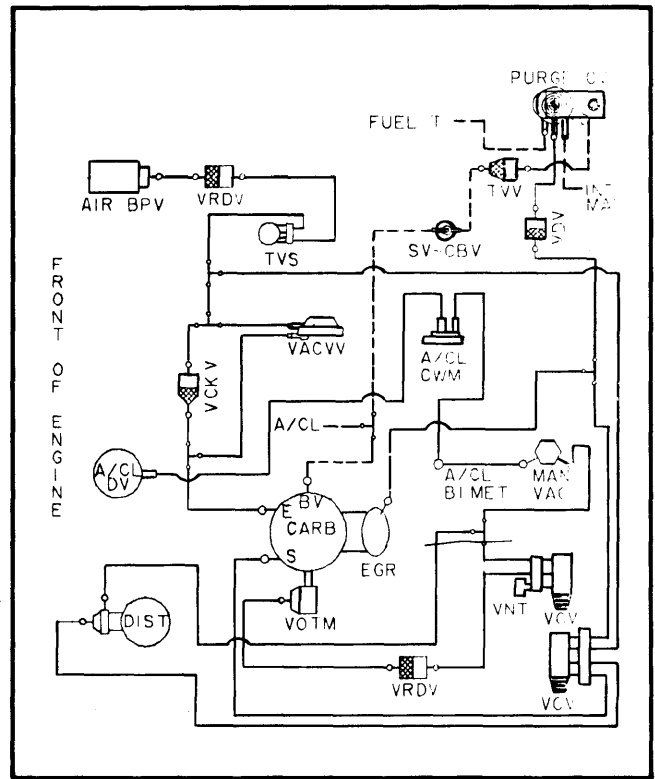

Fig. 78 Calibration 9-11V-R10; 302"; Calif.

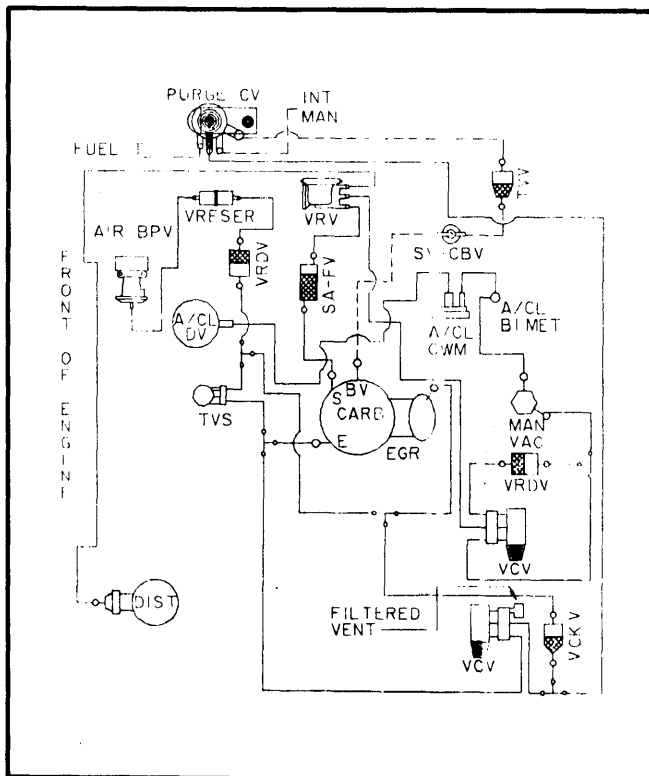

Fig. 79 Calibration 9-11X-R10; 302"; Federal

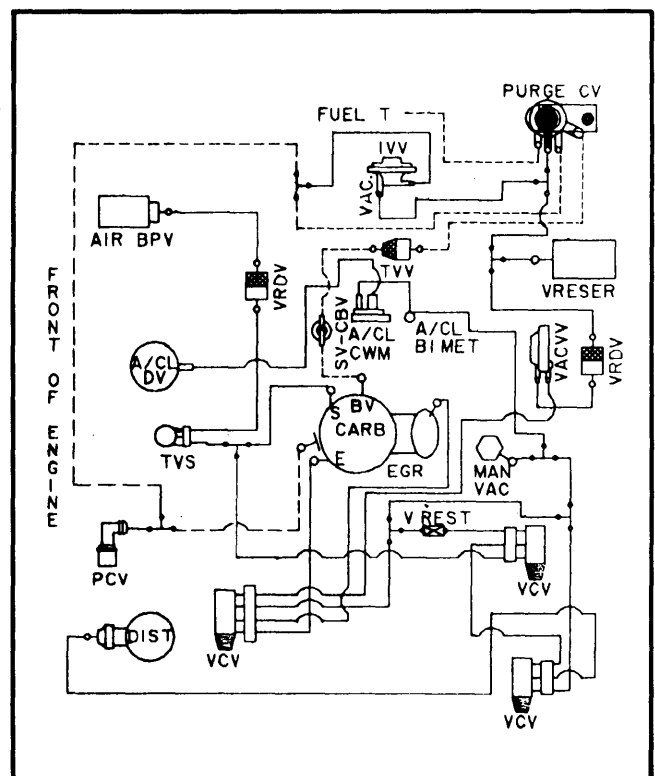

Fig. 80 Calibration 9-11Y-R0; 302"; Federal

1979 EXHAUST EMISSION SYSTEMS Ford Motor Co. Vacuum Diagrams (Cont.)

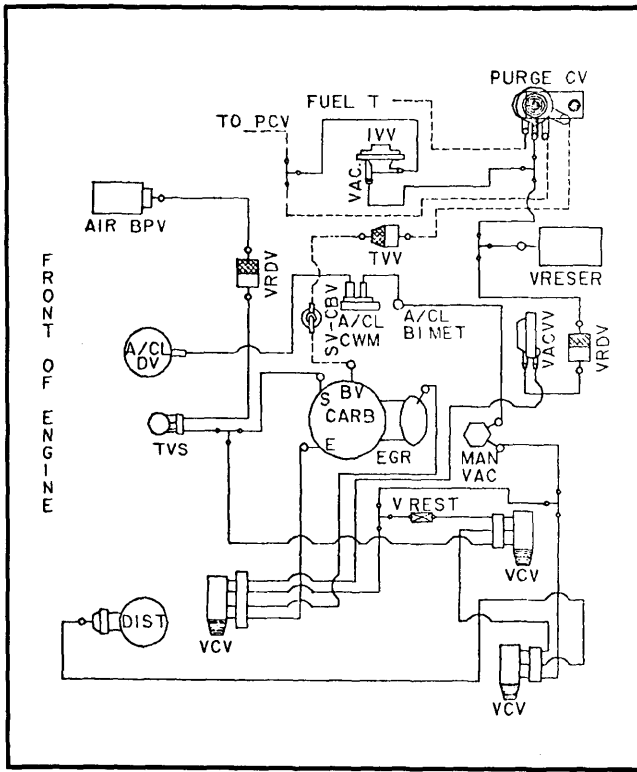

Fig. 81 Calibration 9-11Z-R0; 302"; Federal

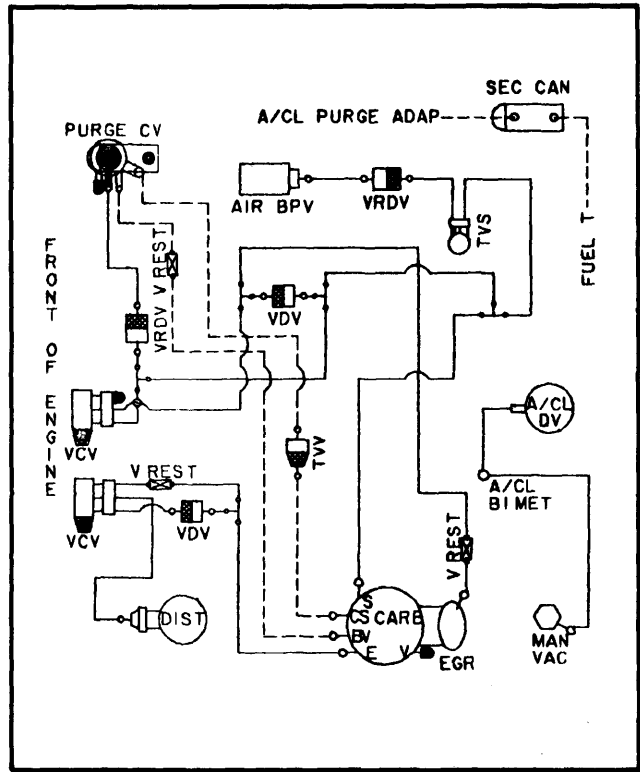

Fig. 82 Calibration 9-14E-R0; 351" M; Federal

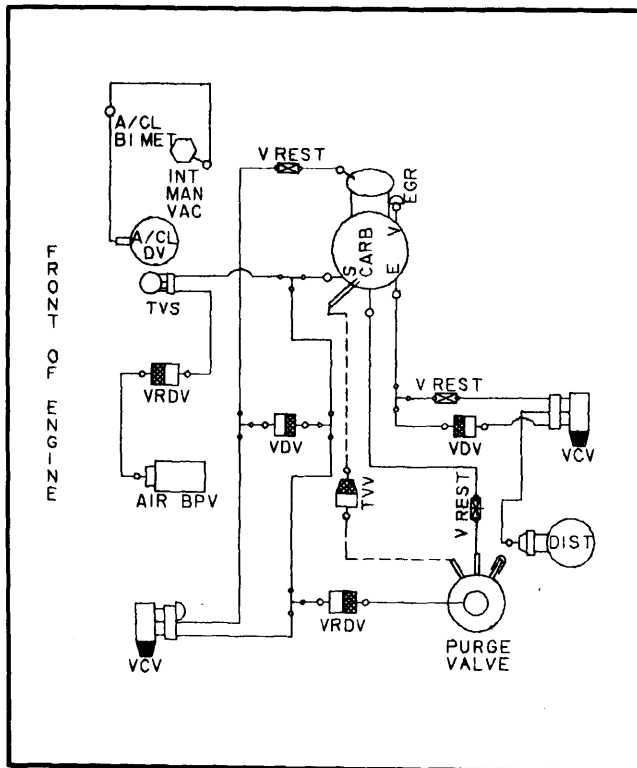

Fig. 83 Calibration 9-14E-R12; 351" M; Federal

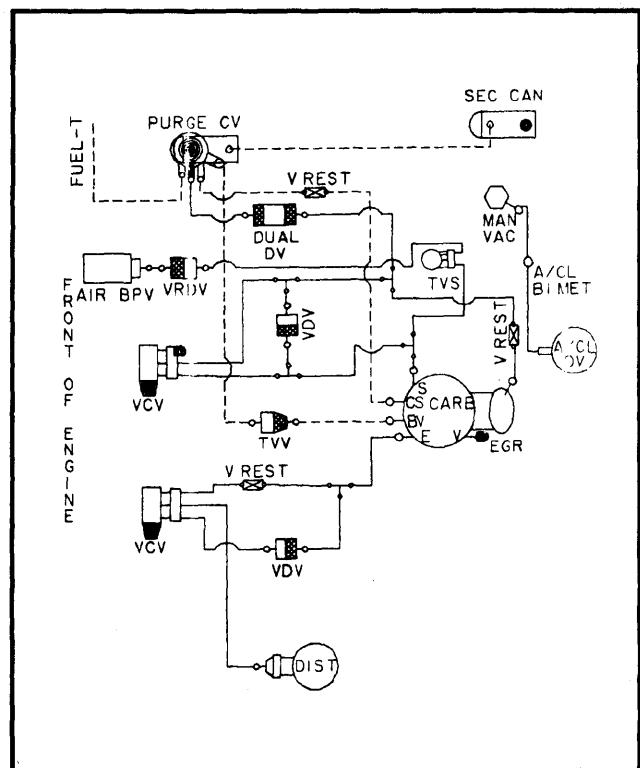

Fig. 84 Calibration 9-14E-R14; 351" M; Federal

1979 EXHAUST EMISSION SYSTEMS Ford Motor Co. Vacuum Diagrams (Cont.)

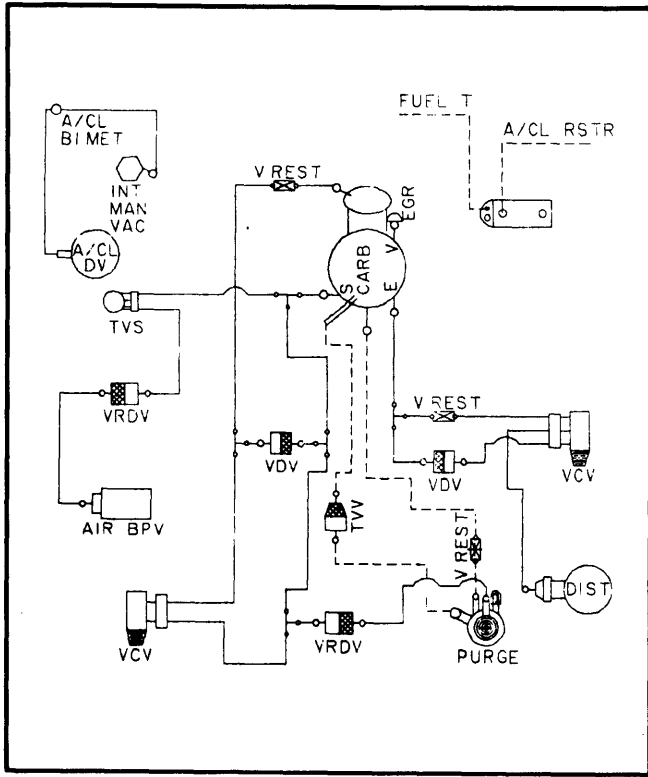

Fig. 85 Calibration 9-14E-R15; 351" M; Federal

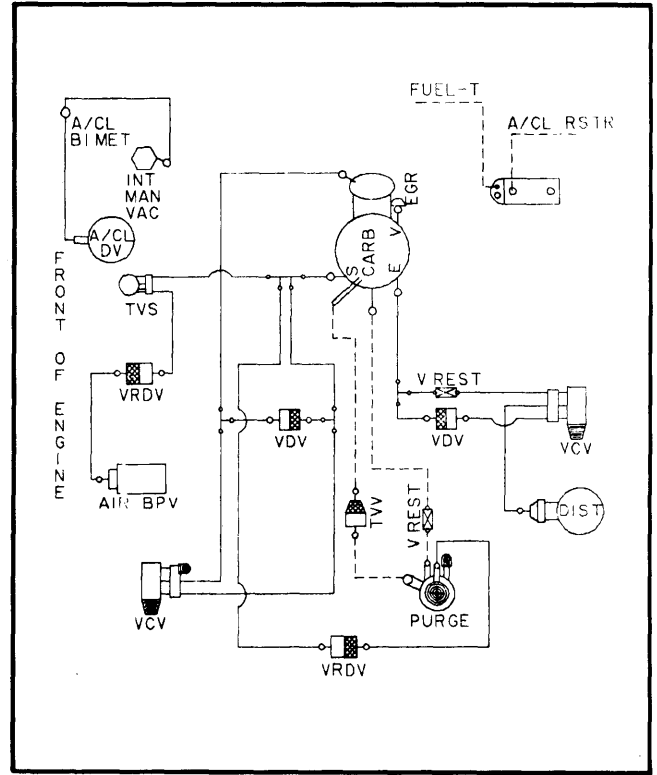

Fig. 86 Calibration 9-14E-R18; 351" M; Federal

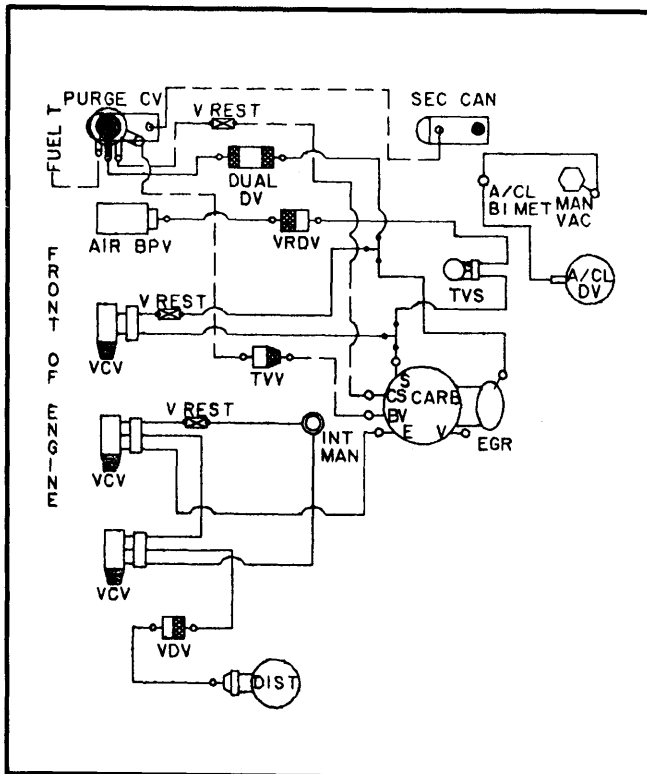

Fig. 87 Calibration 9-14Q-R0; 351" M; Federal

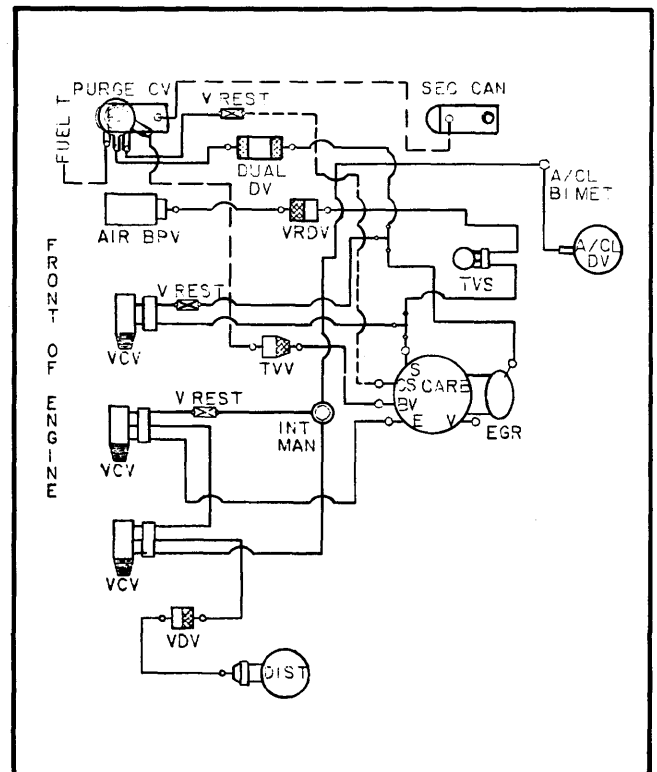

Fig. 88 Calibration 9-14Q-R10; 351" M; Calif.

1979 EXHAUST EMISSION SYSTEMS Ford Motor Co. Vacuum Diagrams (Cont.)

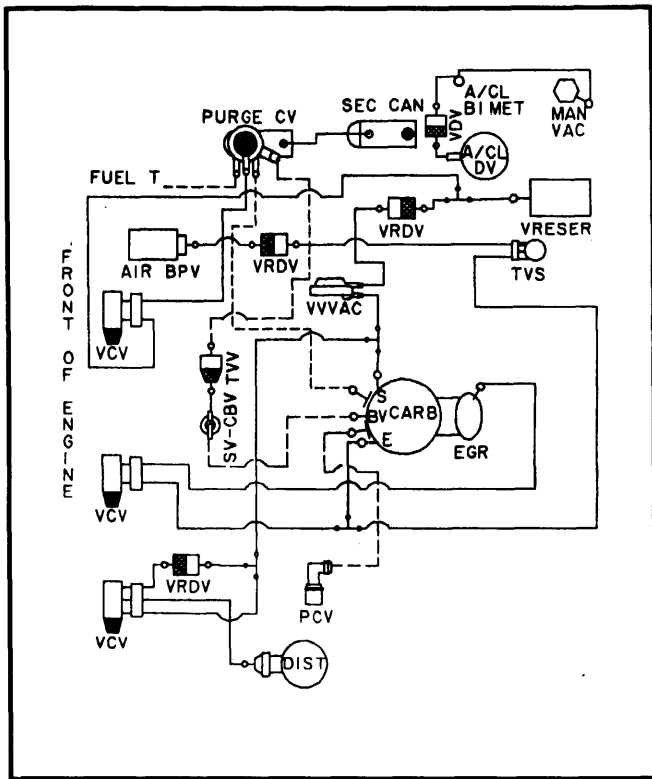

Fig. 89 Calibration 9-14X-R0; 351" M; Federal

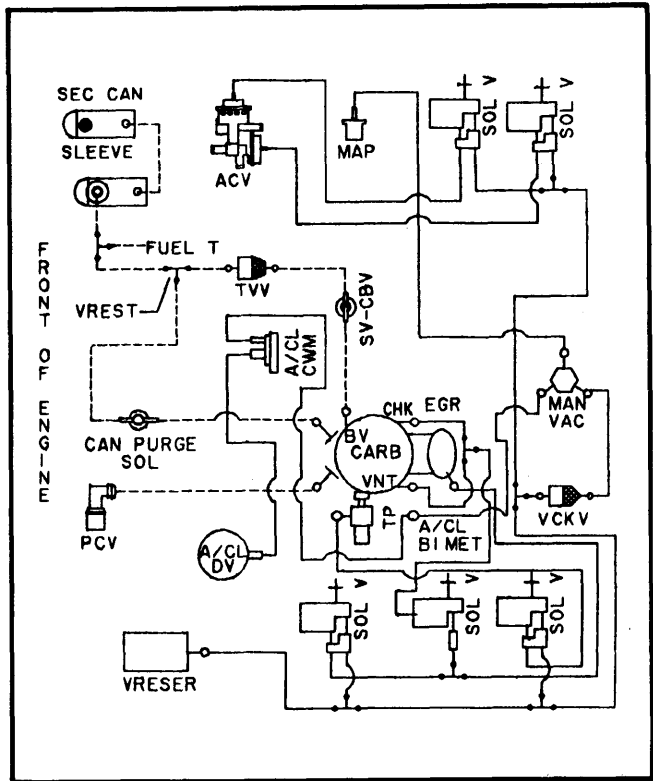

Fig. 90 Calibration 9-12A-R0; 351" W; Federal

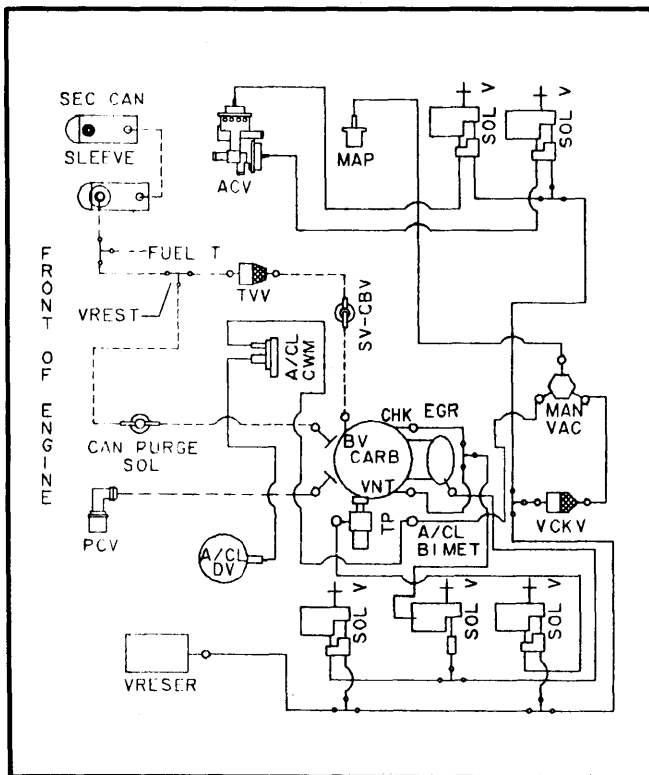

Fig. 91 Calibration 9-12B-R0; 351" W; Federal

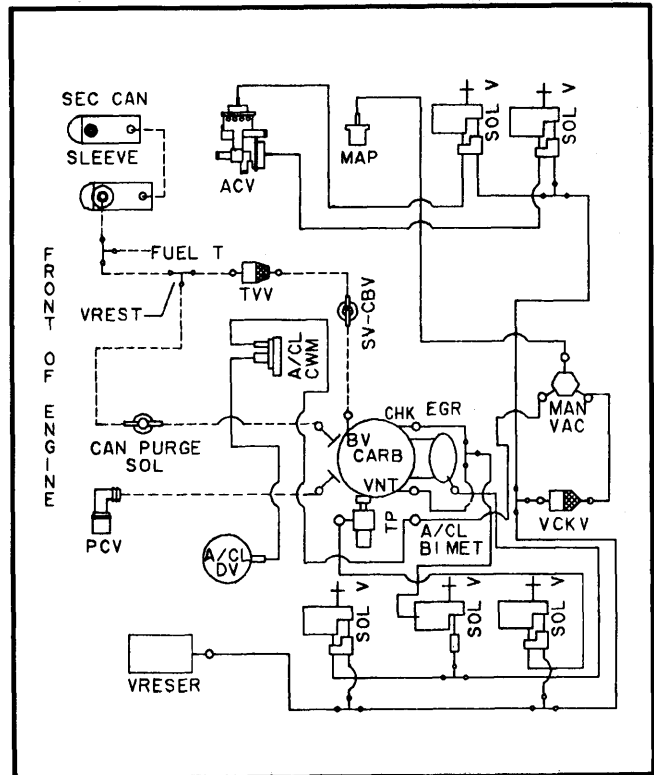

Fig. 92 Calibration 9-12B-R10; 351" W; Federal

1979 EXHAUST EMISSION SYSTEMS Ford Motor Co. Vacuum Diagrams (Cont.)

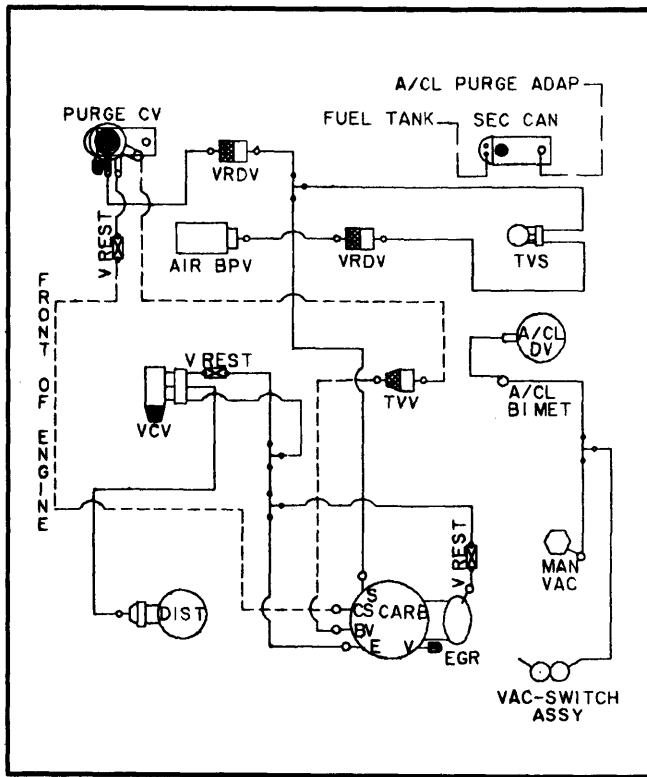

Fig. 93 Calibration 9-12E-R0; 351" W; Federal

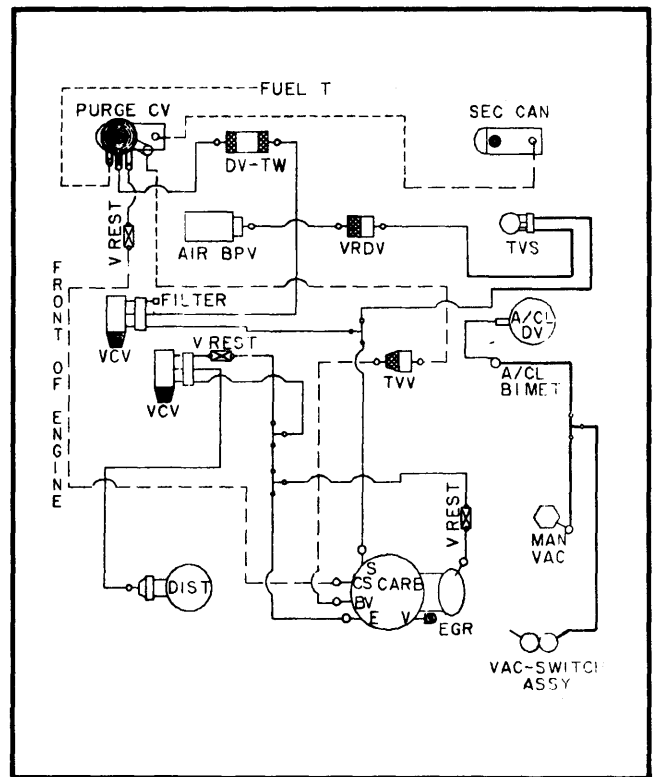

Fig. 94 Calibration 9-12E-R14; 351" W; Federal

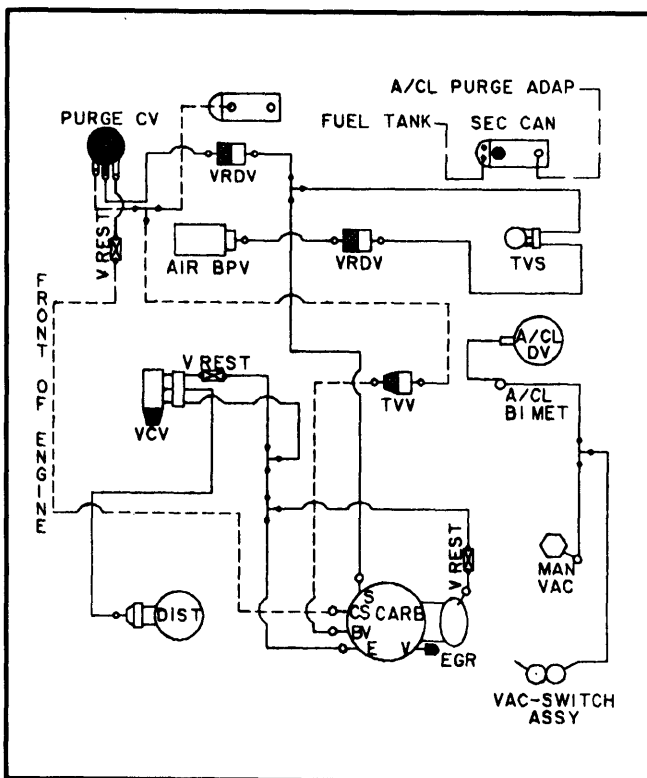

Fig. 95 Calibration 9-12F-R0; 351" W; Federal

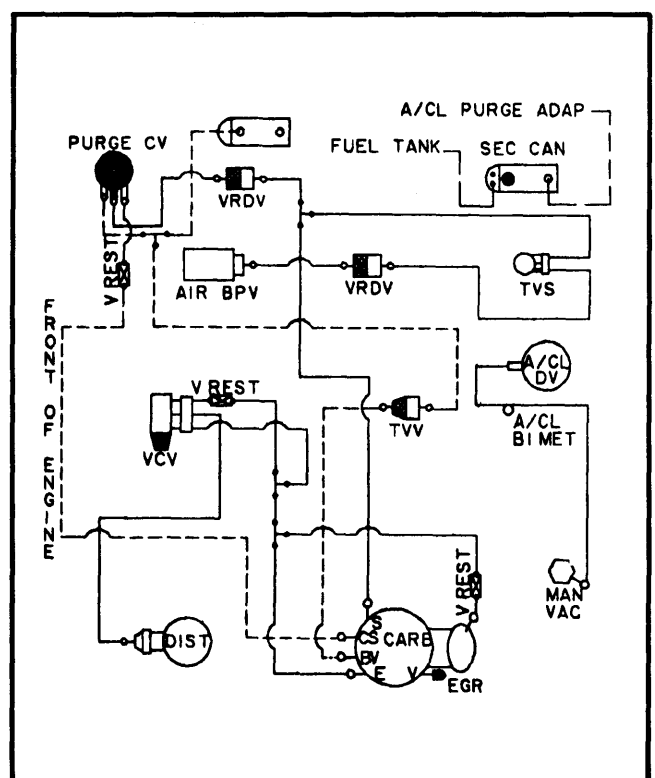

Fig. 96 Calibration 9-12G-R0; 351" W; Federal

1979 EXHAUST EMISSION SYSTEMS

Ford Motor Co. Vacuum Diagrams (Cont.)

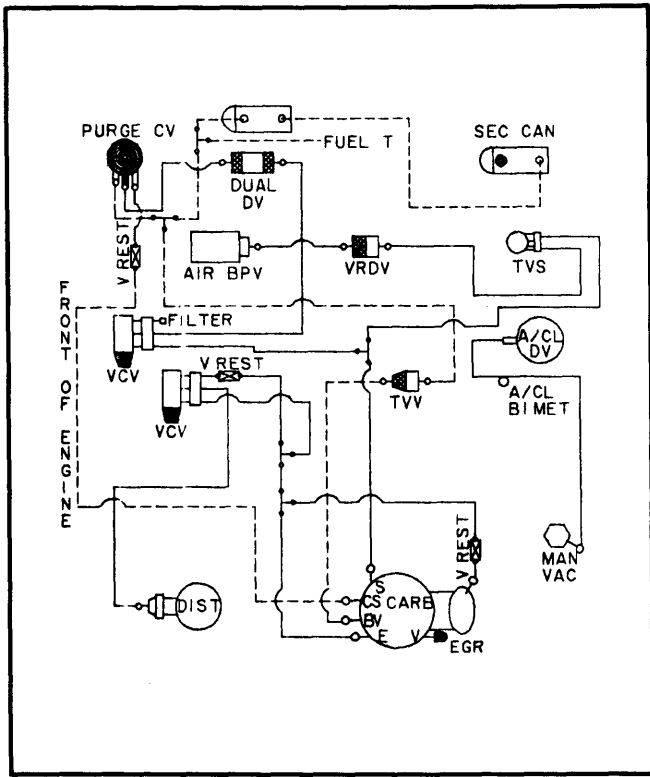

Fig. 97 Calibration 9-12G-R12; 351" W; Federal

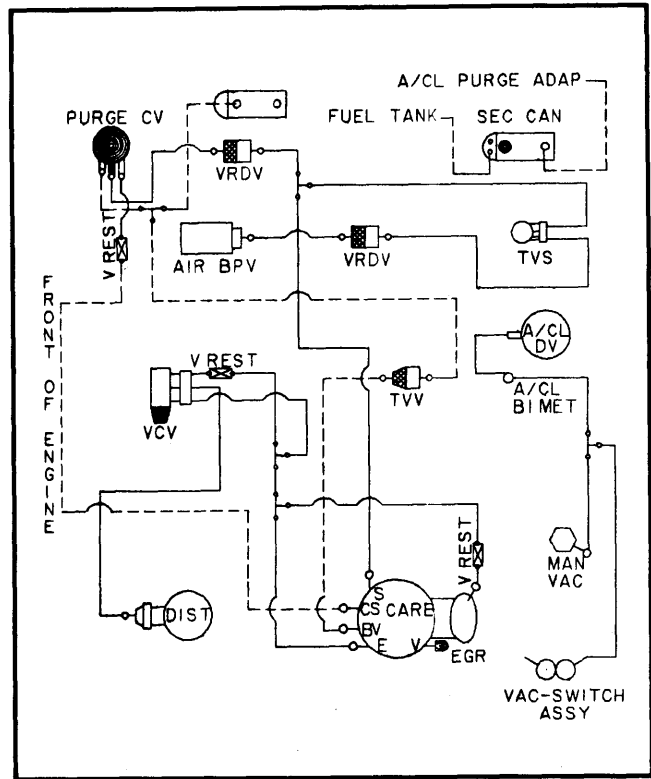

Fig. 98 Calibration 9-12H-R12; 351" W; Federal

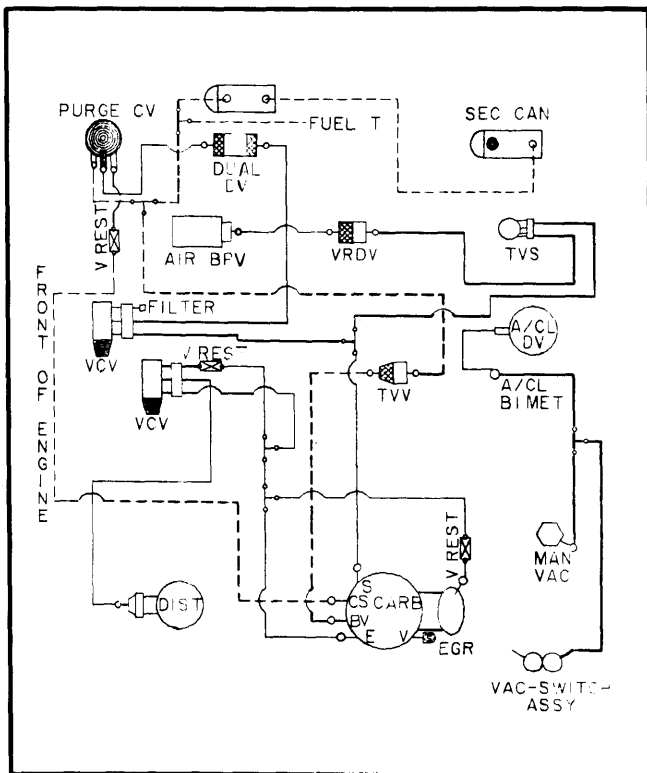

Fig. 99 Calibration 9-12H-R15; 351" W; Federal

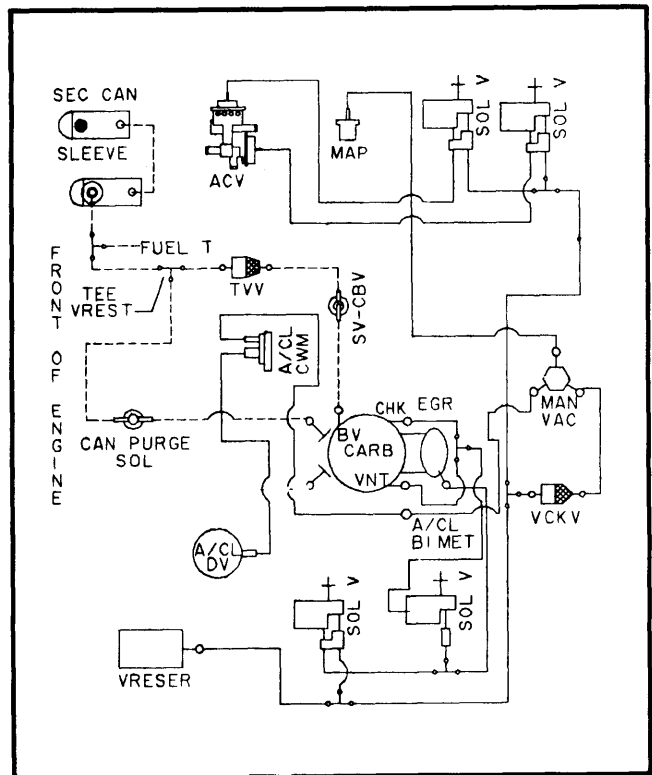

Fig. 100 Calibration 9-12N-R0; 351" W; Calif.

1979 EXHAUST EMISSION SYSTEMS

Ford Motor Co. Vacuum Diagrams (Cont.)

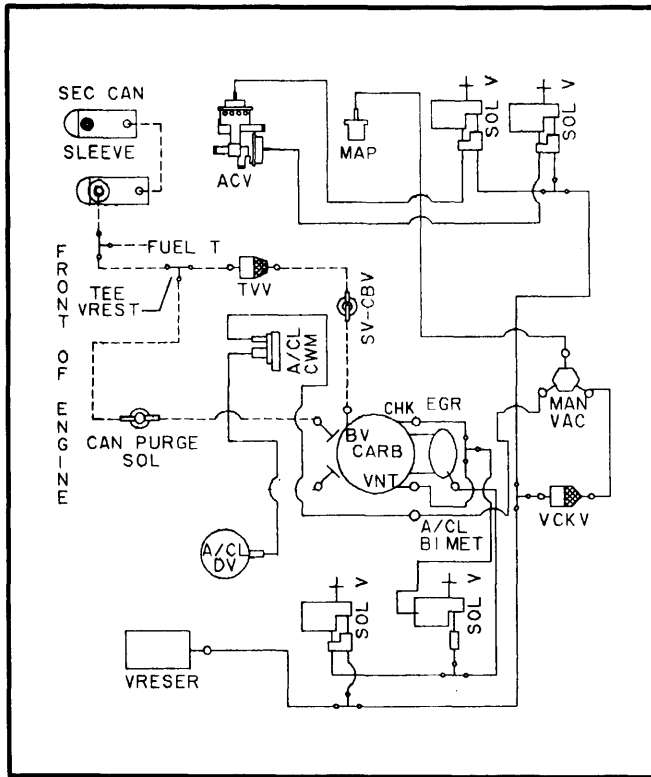

Fig. 101 Calibration 9-12P-R0; 351" W; Calif.

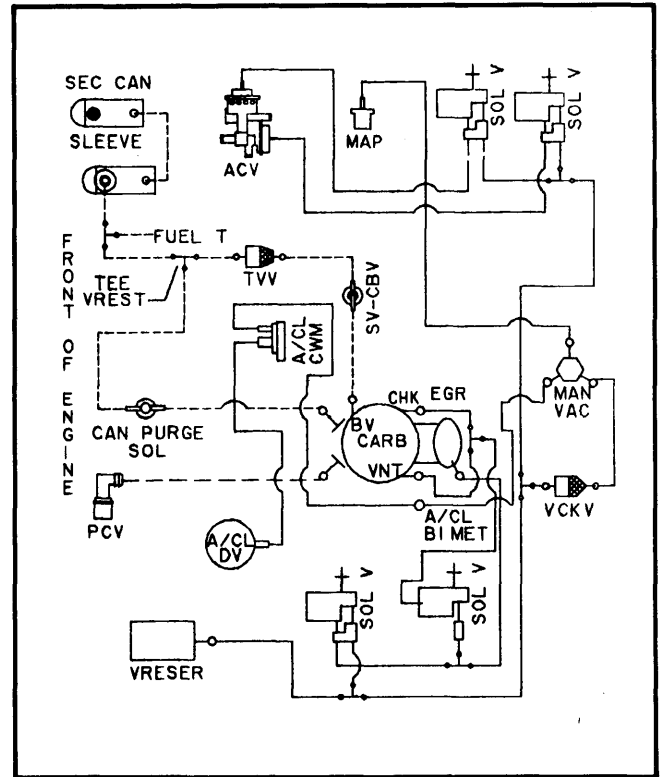

Fig. 102 Calibration 9-12P-R10; 351" W; Calif.

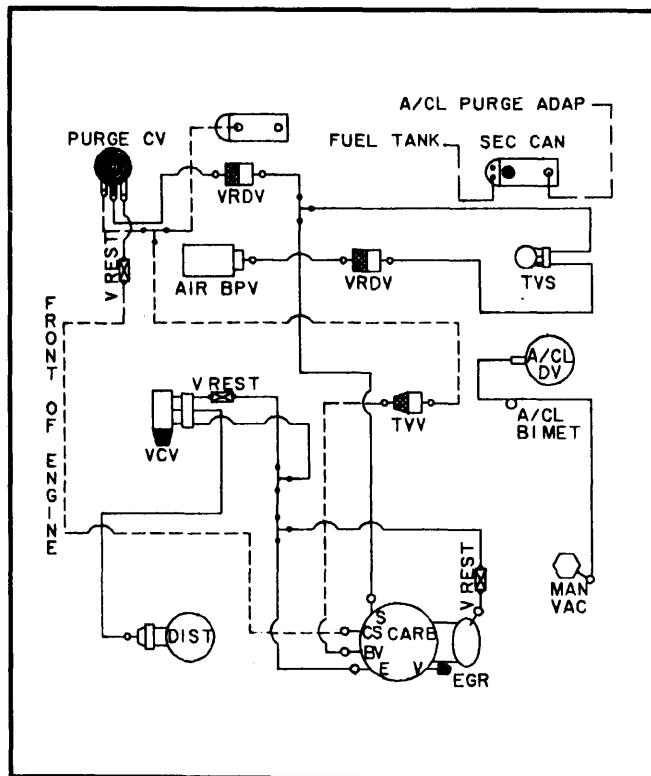

Fig. 103 Calibration 9-12X-R0; 351" W; Calif.

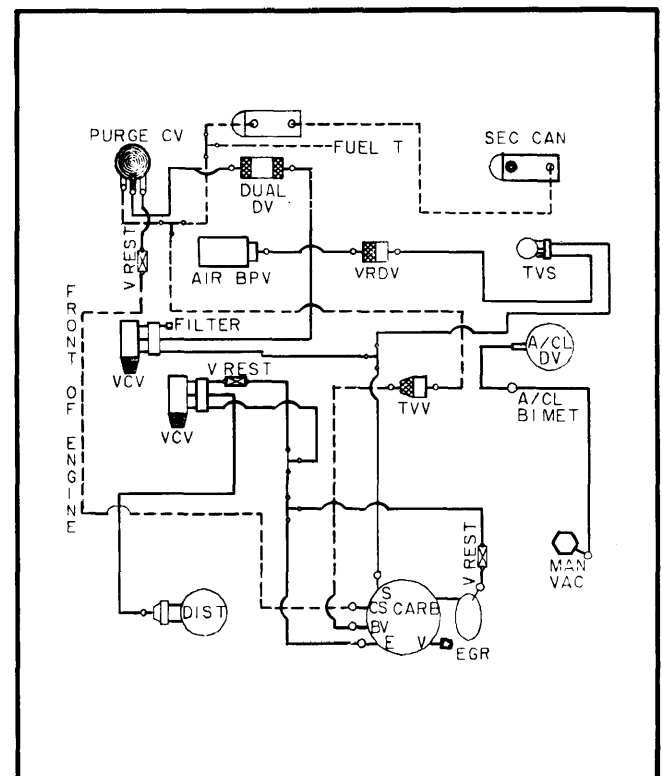

Fig. 104 Calibration 9-12X-R10; 351" W; Calif.

1979 EXHAUST EMISSION SYSTEMS Ford Motor Co. Vacuum Diagrams (Cont.)

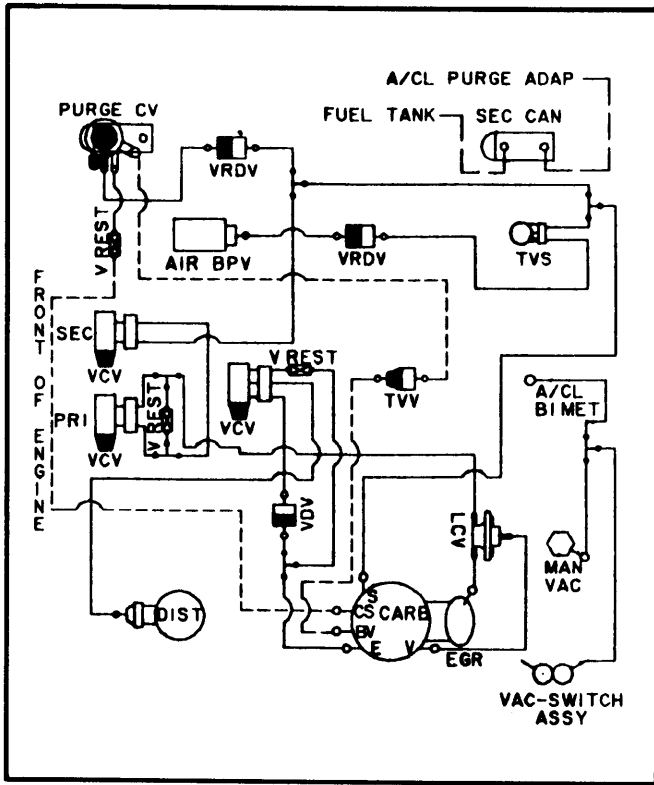

Fig. 105 Calibration 9-17F-R0; 400"; Federal

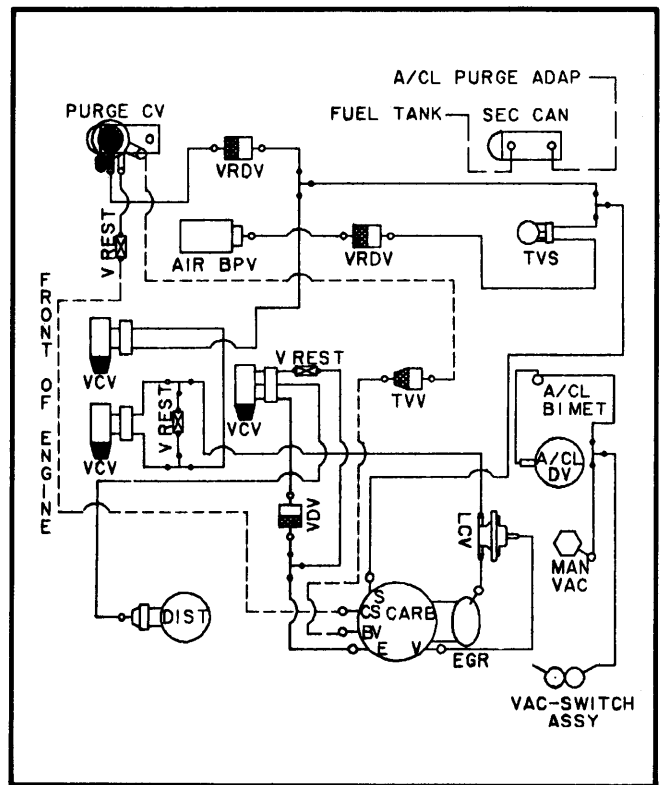

Fig. 106 Calibration 9-17F-R1; 400"; Federal

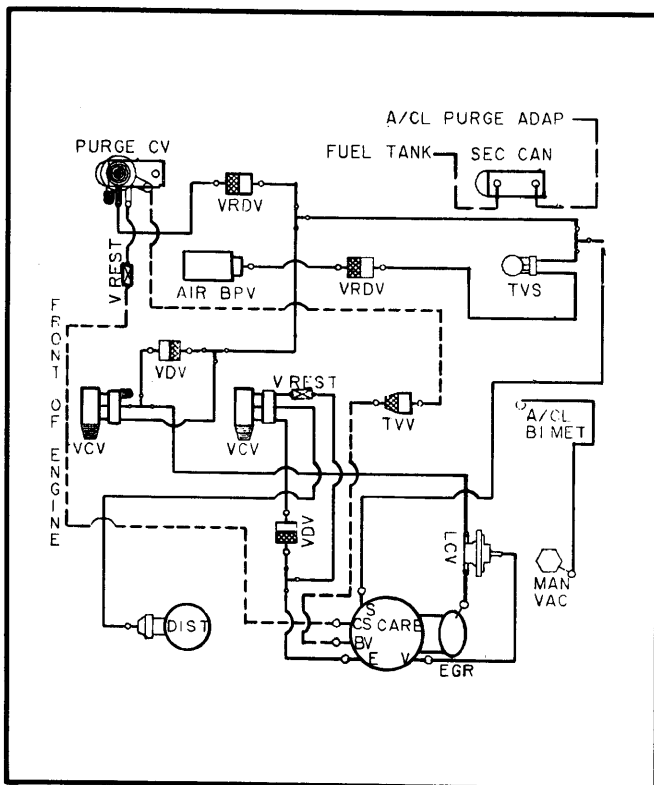

Fig. 107 Calibration 9-17F-R21; 400"; Federal

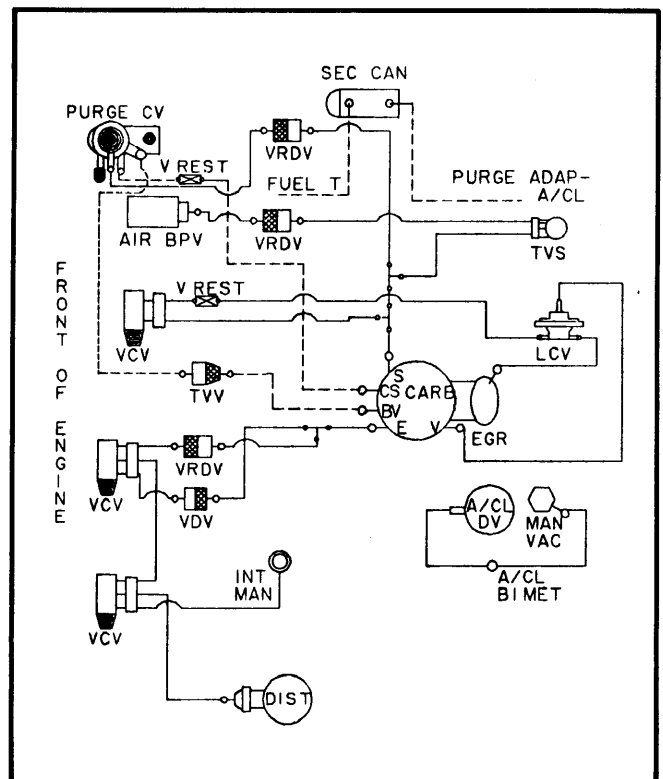

Fig. 108 Calibration 9-17P-R0; 400"; Calif.

1979 EXHAUST EMISSION SYSTEMS Ford Motor Co. Vacuum Diagrams (Cont.)

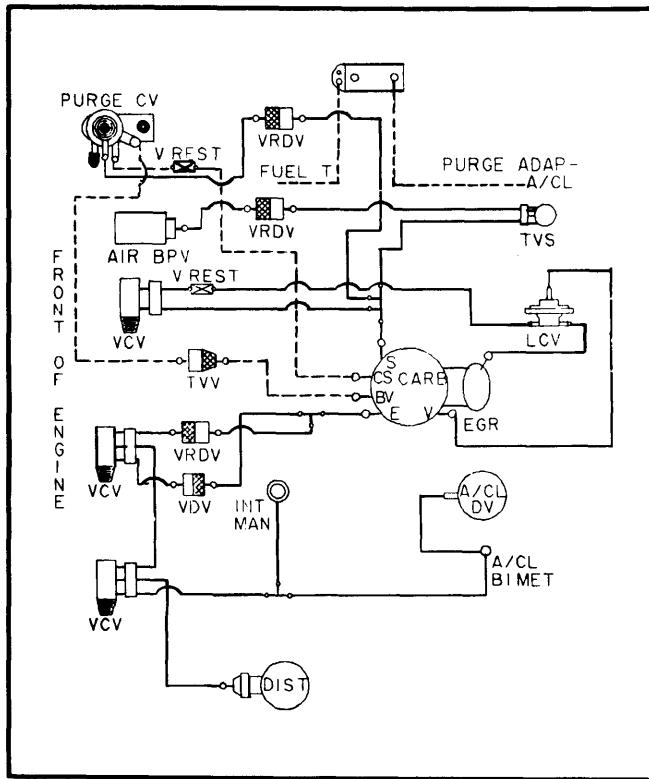

Fig. 109 Calibration 9-17P-R10; 400"; Calif.

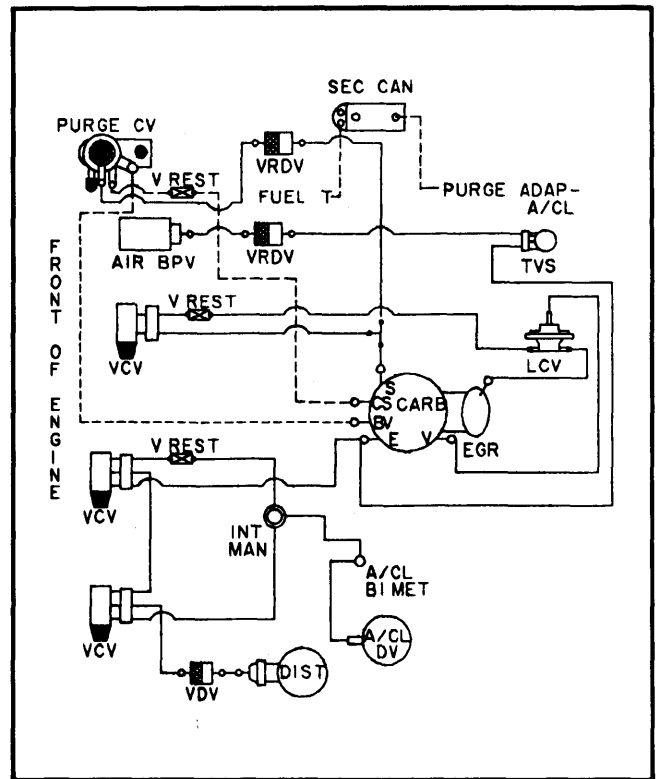

Fig. 110 Calibration 9-17Q-R0; 400"; Calif.

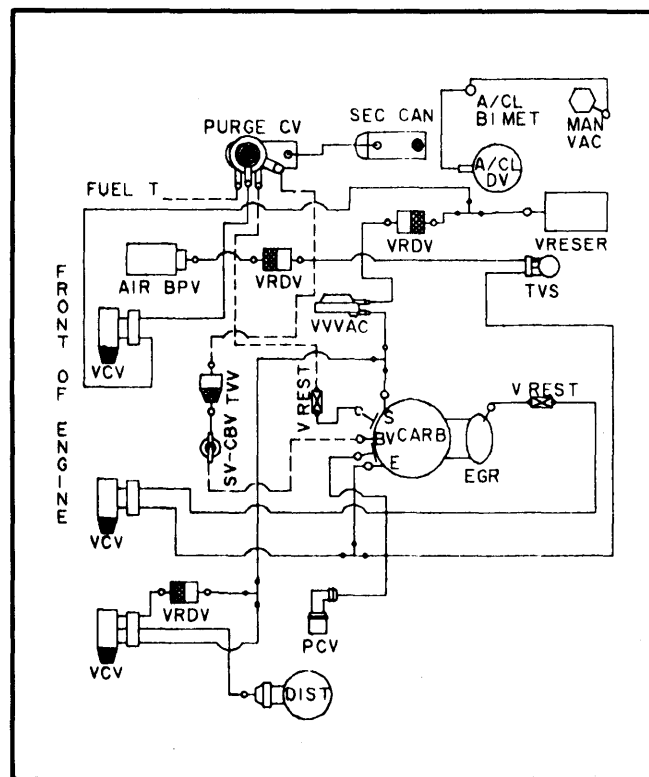

Fig. 111 Calibration 9-17X-R0; 400"; Federal