

1975-79 EXHAUST EMISSION SYSTEMS

Ford Motor Co. Ported Vacuum Switches

DESCRIPTION

Ported Vacuum Switches (PVS) are temperature sensitive vacuum controlling devices. PVS valves have 2, 3 or 4 ports. An electric PVS is used on some engines with catalytic converters and air injection. The coolant and exhaust gas recirculation PVS valves have 3 temperature ranges. See PVS COLOR CODES CHART. The electric PVS is a combined vacuum switching and electric signalling device. There are 2 versions of the electric PVS valve. One with normally closed contacts and one with normally open contacts.

OPERATION

2-Port PVS - The 2-port PVS is a vacuum on or vacuum off device depending on engine coolant temperature. When coolant temperature is below PVS temperature range, vacuum is shut off. When coolant temperature is above PVS temperature range, vacuum will pass through PVS.

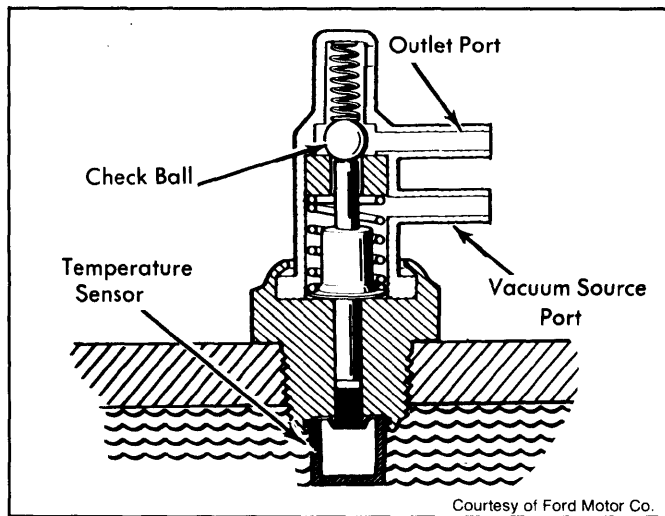

Fig. 1: 2-Port PVS Valve

3-Port PVS - On a 3-port PVS valve the center port is connected to a vacuum source. The top port is open and the bottom port is closed to the center port when coolant temperature is below PVS temperature range. The bottom port is open and the top port is closed to the center port when coolant temperature is above PVS temperature range.

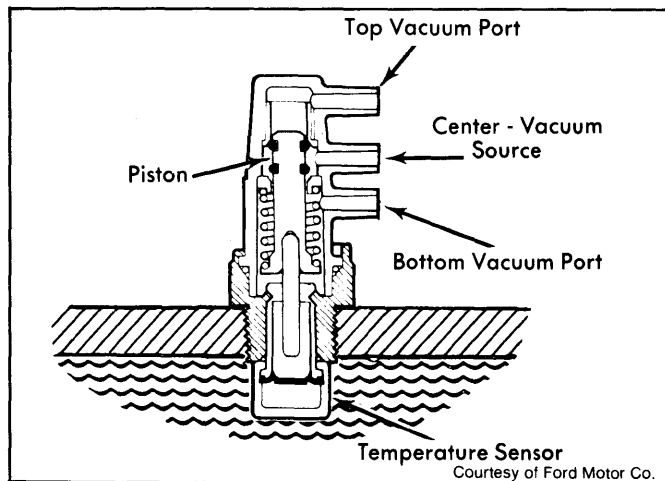

Fig. 2: 3-Port PVS Valve

4-Port PVS - On a 4-port PVS valve the top port is connected to a vacuum source. Second port is connected to a vacuum check valve and is then tee'd into vacuum hose to distributor. Third port is

connected to EGR valve. Fourth port is connected to a vacuum amplifier.

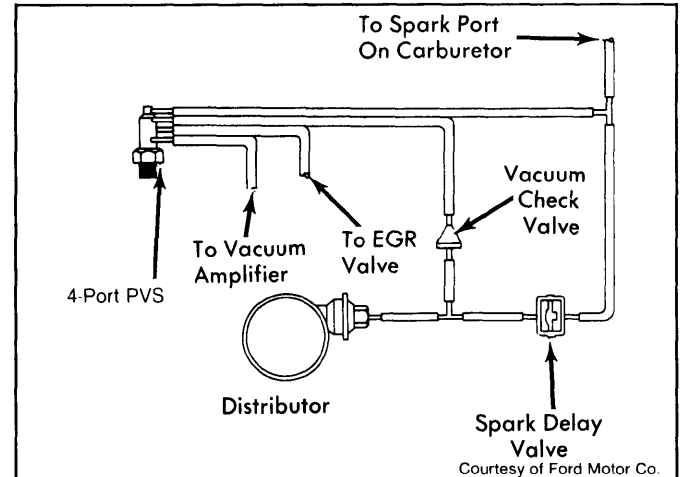

Fig. 4: 4-Port PVS System

Electric-Ported Vacuum Switch - Electric PVS is only used on some engines equipped with Air Injection System (AIS) and a catalytic converter. Two electric PVS valves are used, normally closed contacts and normally open contacts. On both types of valves the center and bottom ports operate in the same manner as a regular 3-port PVS. On normally closed contact valve, the contact is closed until coolant temperature reaches 235°F, at which time the contact opens. On the normally open contact valve, the contact is open until coolant temperature reaches 235°F, at which time the contact closes.

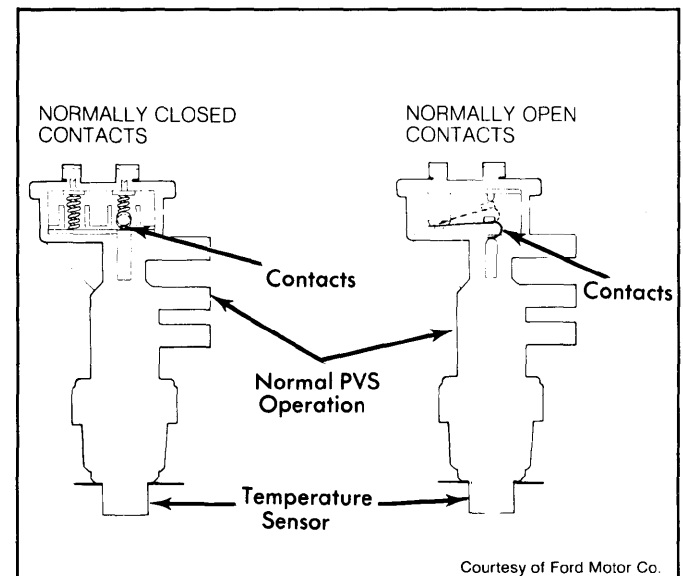

Fig. 3: Electric PVS Valve

TESTING

2-Port PVS - With cold engine and bottom port on PVS connected to vacuum source the top port should have no vacuum reading. With coolant temperature above the PVS range, see PVS COLOR CODES CHART, top port should have same vacuum as bottom port. If PVS fails to operate as described, replace valve.

1975-79 EXHAUST EMISSION SYSTEMS

Ford Motor Co. Ported Vacuum Switches (Cont.)

PVS COLOR CODES CHART

PVS Color	Temp.
Green	Above 68°F
Pink or Natural	Above 90°F
Black	Above 100°F
Plain 2-Tone or Blue	Above 133°F
Yellow or Gray	Above 155°F

3-Port PVS - With cold engine and center port connected to vacuum source, top port should have same vacuum as center port. Raise coolant temperature above PVS range. See PVS COLOR CODES CHART. Top port should close to vacuum and bottom port should open to center port. If PVS fails to operate as described, replace valve.

4-Port PVS - With engine coolant temperature above PVS calibration temperature, see PVS COLOR CODES CHART, disconnect vacuum hoses connected to top 2 ports (marked "D" and "M") of PVS. Connect a vacuum gauge to one port and a vacuum source to other port. There should be no vacuum reading on gauge. If vacuum is present, replace PVS valve. Reconnect top vacuum hoses. Disconnect bottom 2 vacuum hoses from PVS ports (marked "E" and "S"). Connect vacuum source to one port and vacuum gauge to other. Vacuum should be indicated on gauge, if not replace PVS valve. Reconnect vacuum hoses.

NOTE: Coolant temperature must remain above PVS calibration. Start and idle engine if necessary.

Electric PVS - On the electrical PVS, the PVS section should be checked in same manner as a regular 3-port PVS. To check the electrical section, proceed as follows: Connect a self-powered test light. See Fig. 5. On the normally closed switch with the coolant

temperature cold the light should glow. With coolant temperature hot (235°F), the light should not glow. On the normally open switch with coolant temperature cold, the light should not glow. With coolant temperature hot (235°F) the light should glow. If either section of the electric PVS fails to operate as described, replace valve.

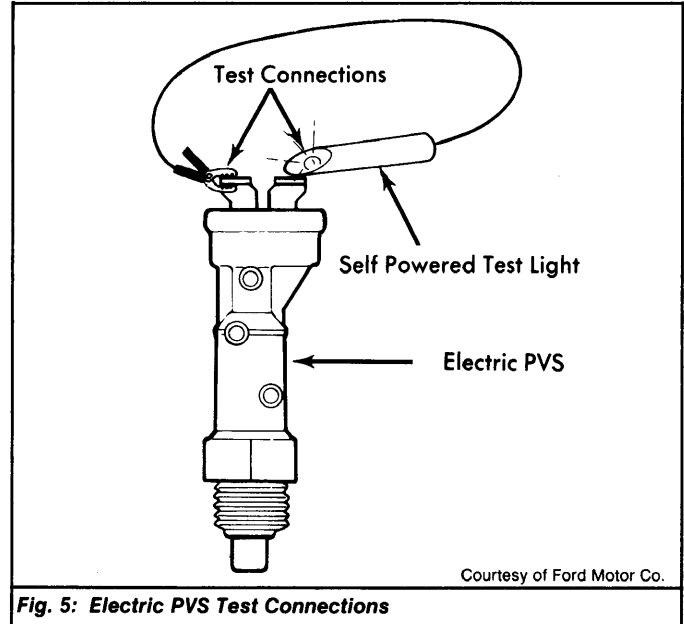

Fig. 5: Electric PVS Test Connections