

# 1977 EXHAUST EMISSION SYSTEMS Chrysler Corp. Vacuum Diagrams

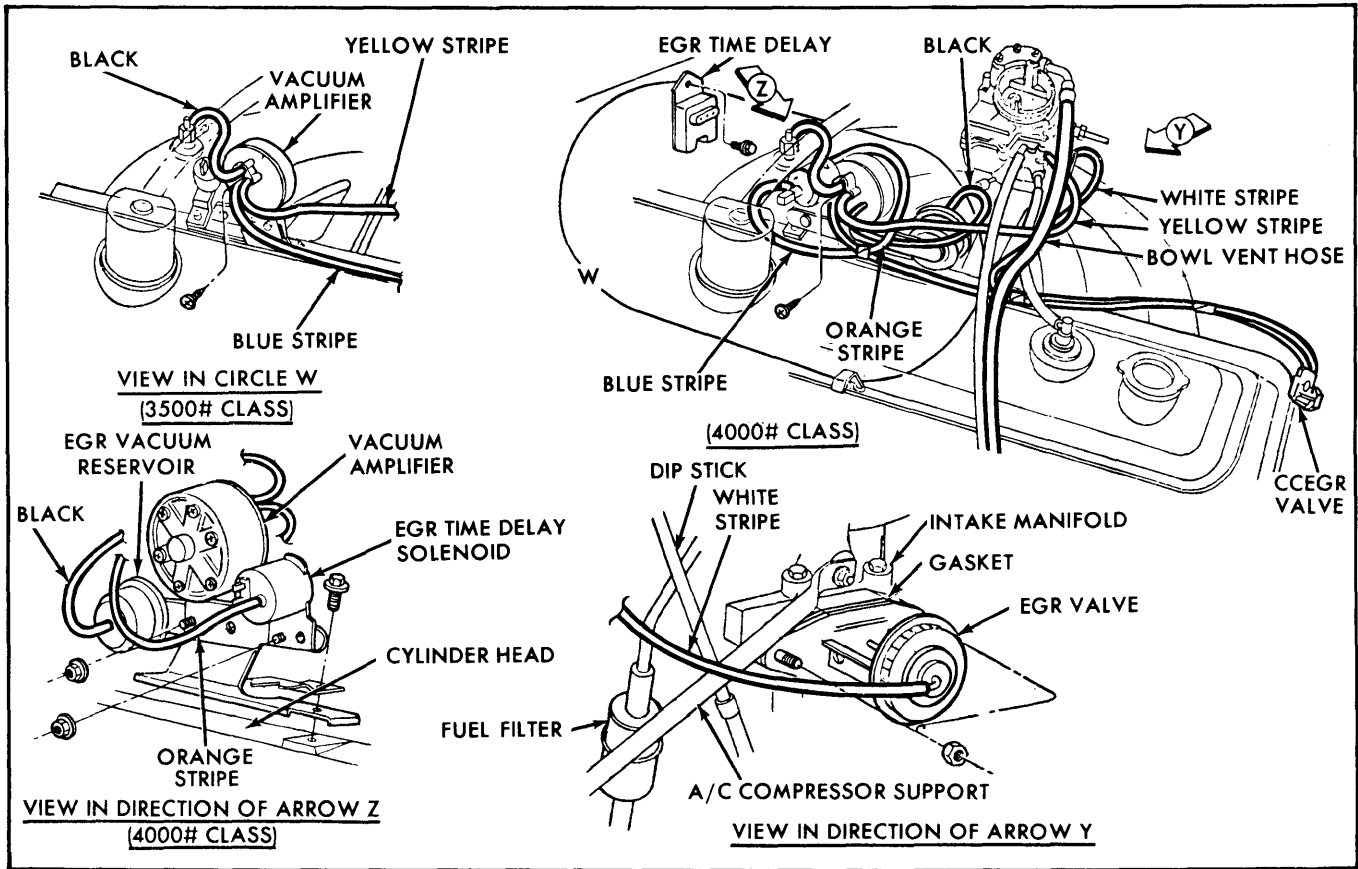

Fig. 1 EGR Vacuum Hose Routing for 225 CID with 1-Bbl. (Federal)

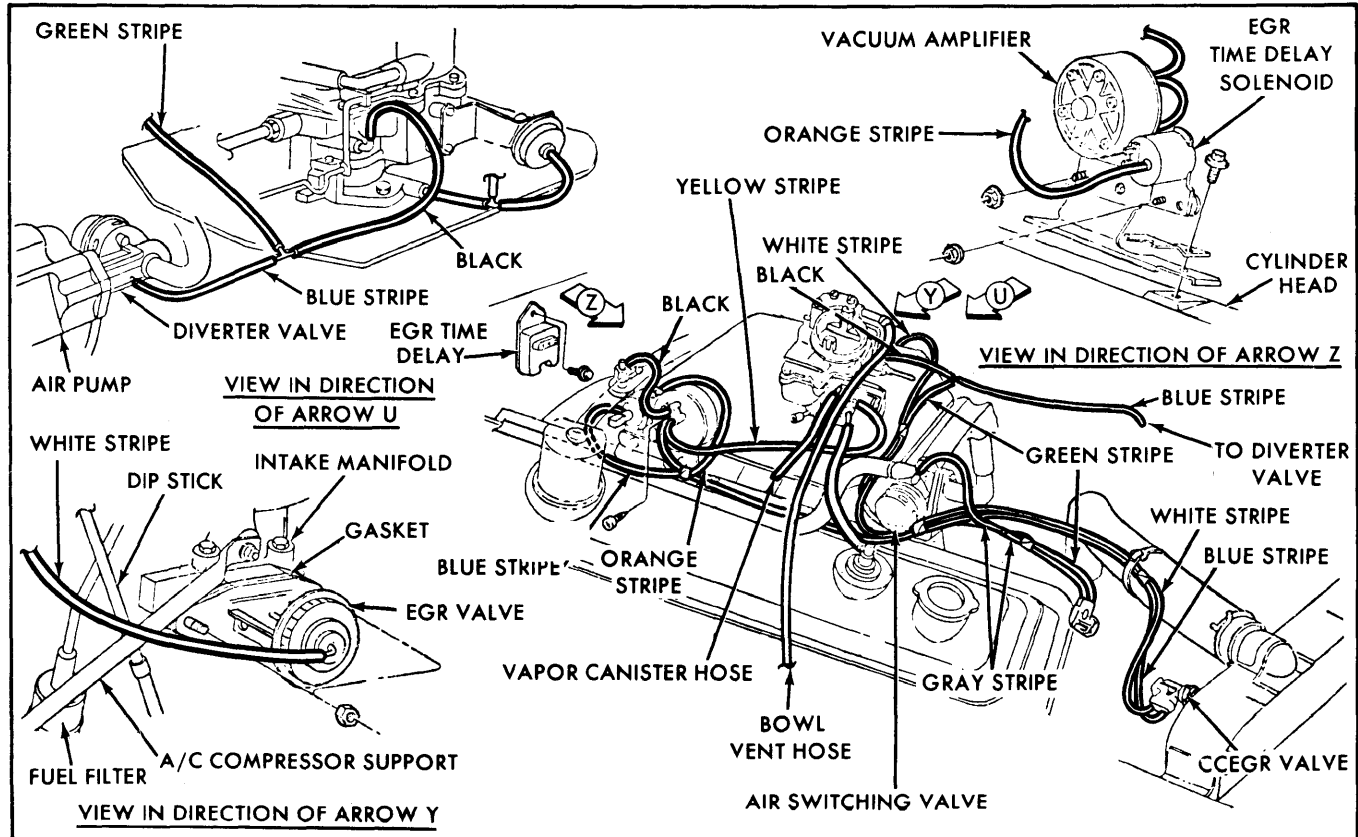

Fig. 2 EGR Vacuum Hose Routing for 225 CID with 1-Bbl. (Calif.)

# 1977 EXHAUST EMISSION SYSTEMS Chrysler Corp. Vacuum Diagrams (Cont.)

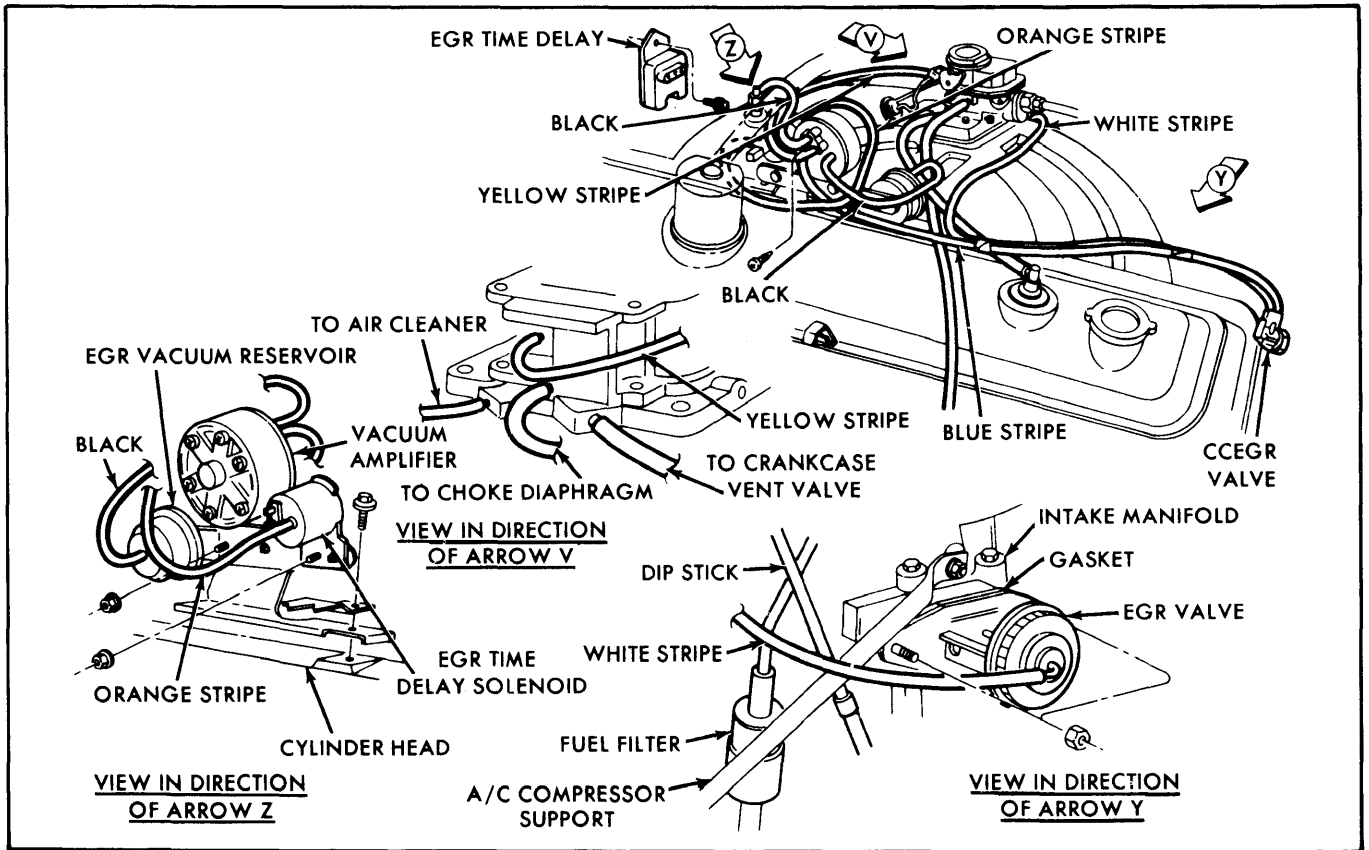

Fig. 3 EGR Vacuum Hose Routing for 225 CID with 2-Bbl. (Federal)

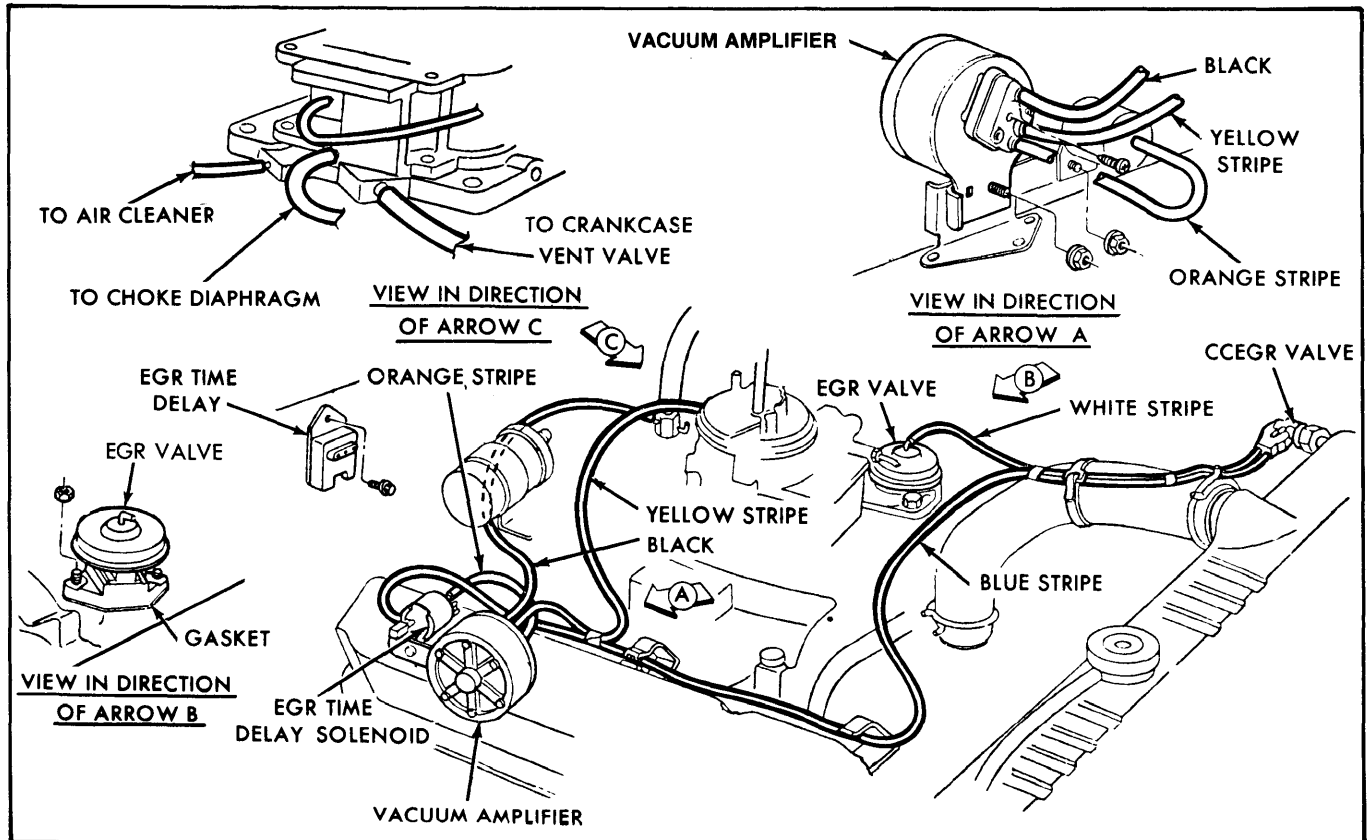

Fig. 4 EGR Vacuum Hose Routing for 318 CID with Man. Trans. (Federal)

# 1977 EXHAUST EMISSION SYSTEMS Chrysler Corp. Vacuum Diagrams (Cont.)

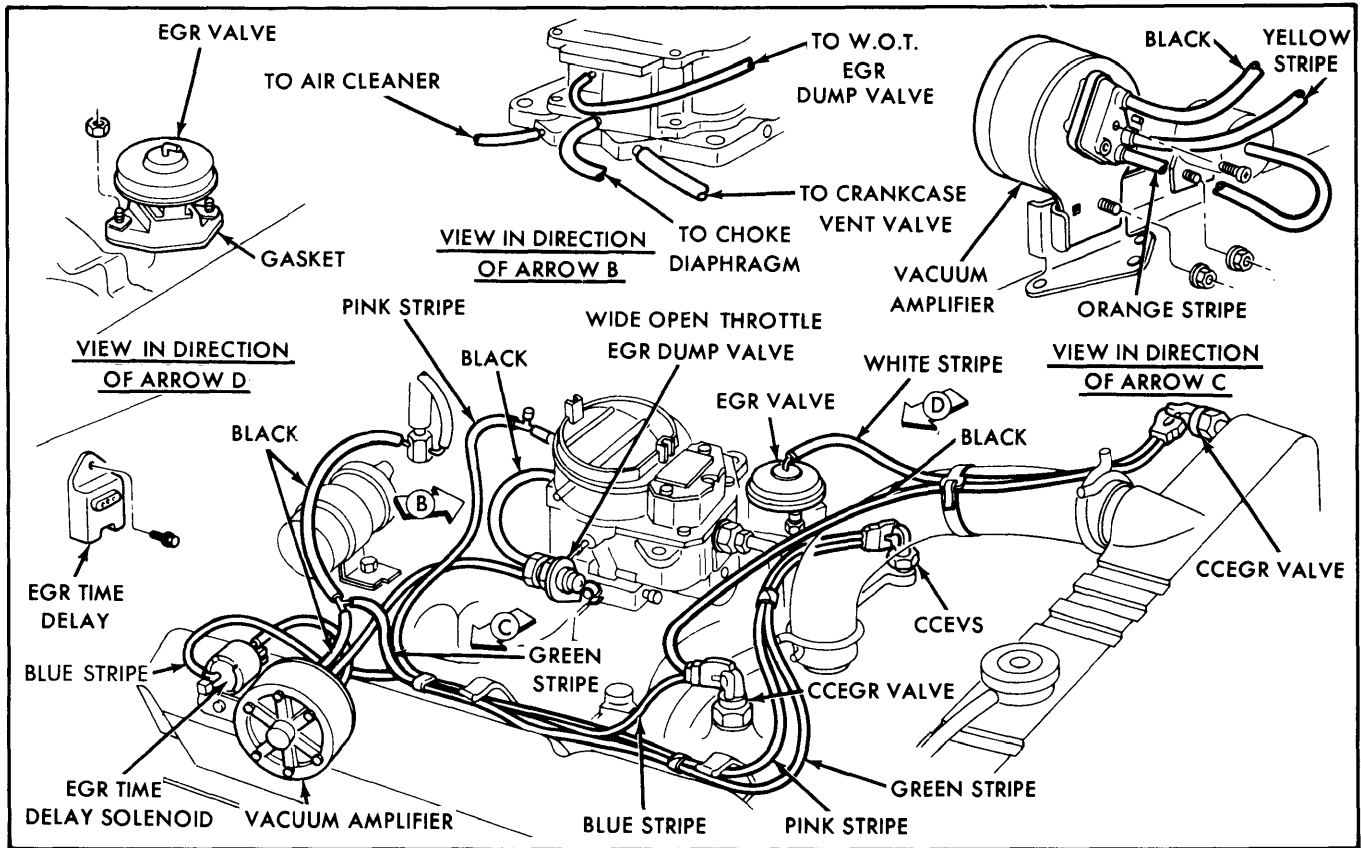

Fig. 5 EGR Vacuum Hose Routing for 318 CID with Auto. Trans. (Federal)

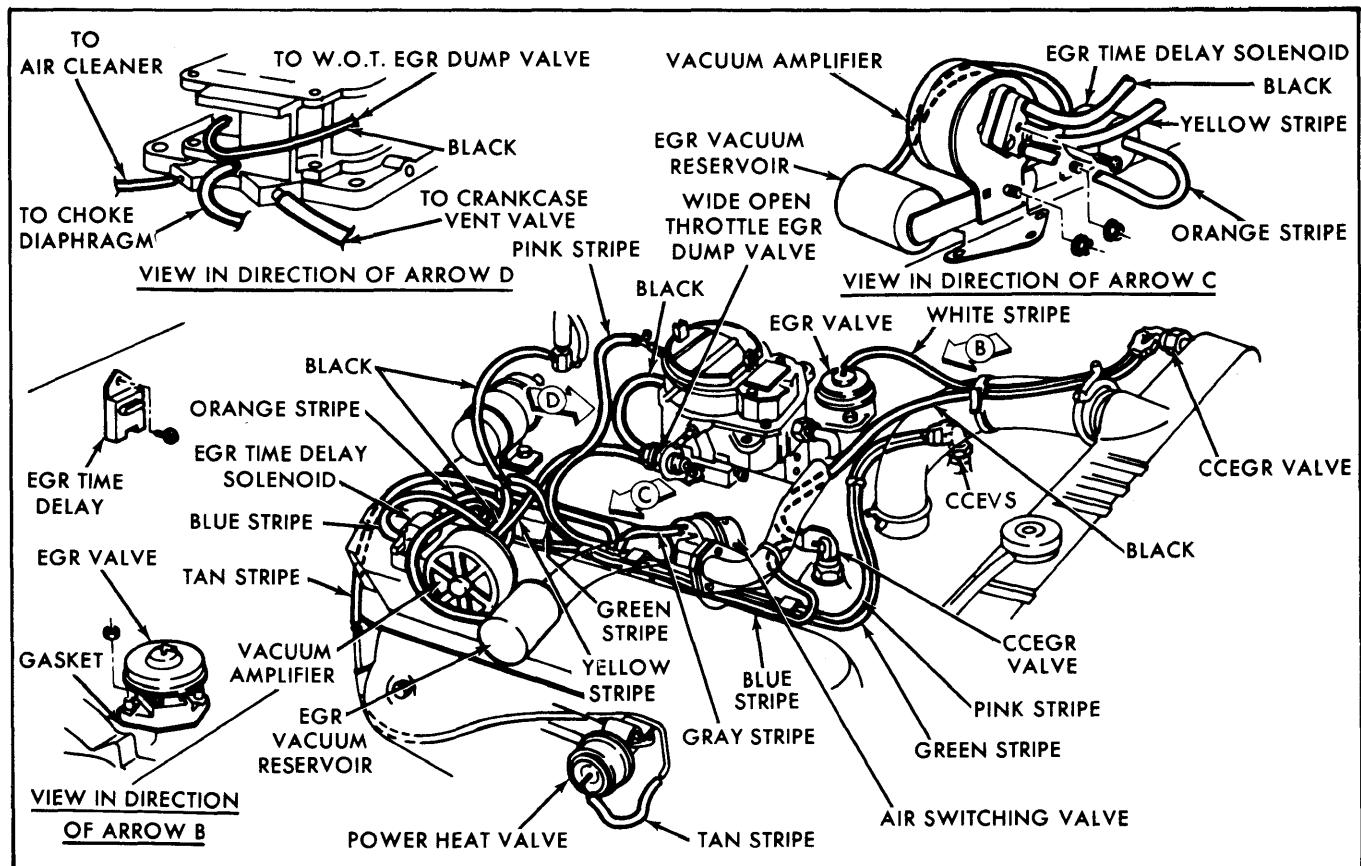

Fig. 6 EGR Vacuum Hose Routing for 318 CID with Auto. Trans. (Calif.)

# 1977 EXHAUST EMISSION SYSTEMS Chrysler Corp. Vacuum Diagrams (Cont.)

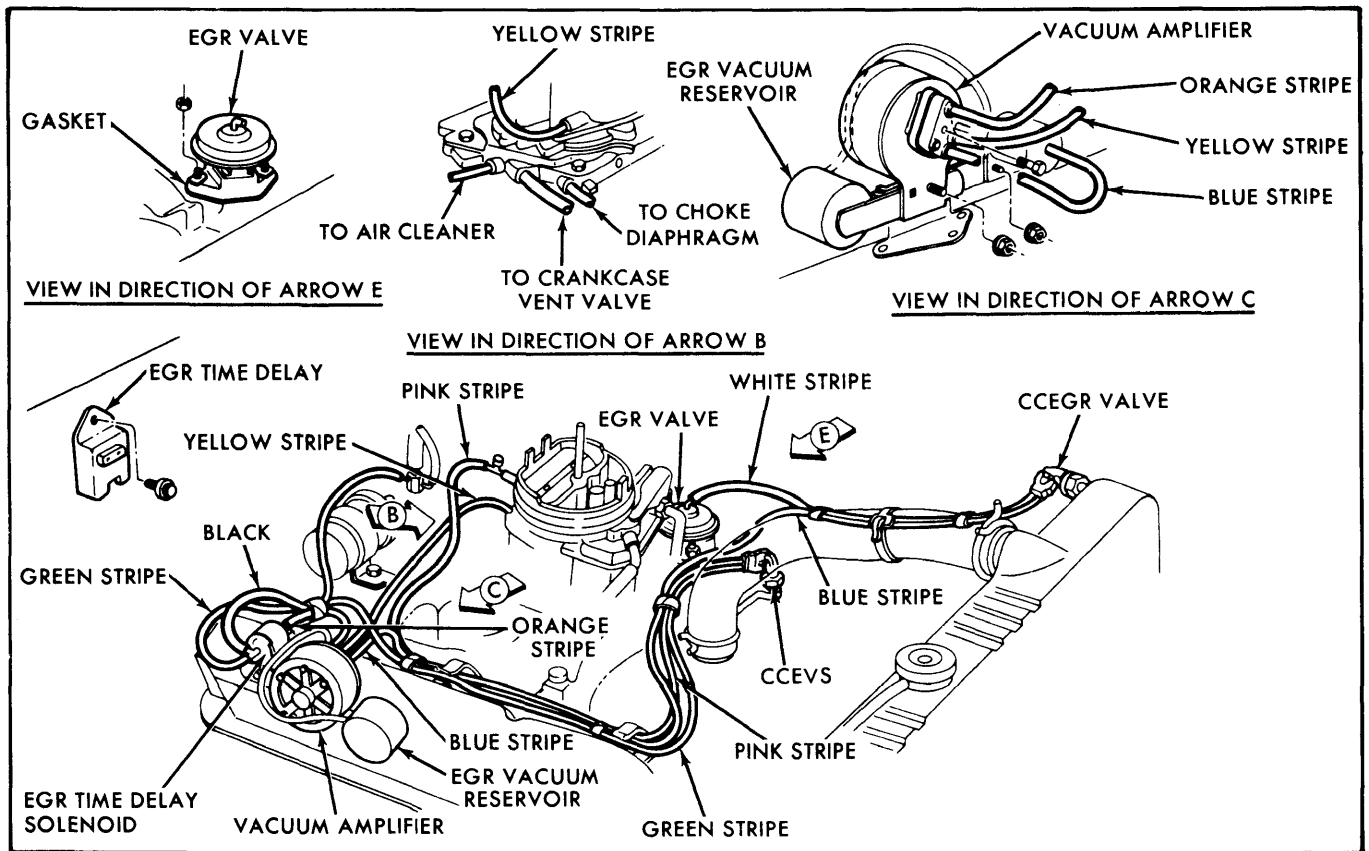

Fig. 7 EGR Vacuum Hose Routing for 360 CID with 2-Bbl. & Auto. Trans. (All States)

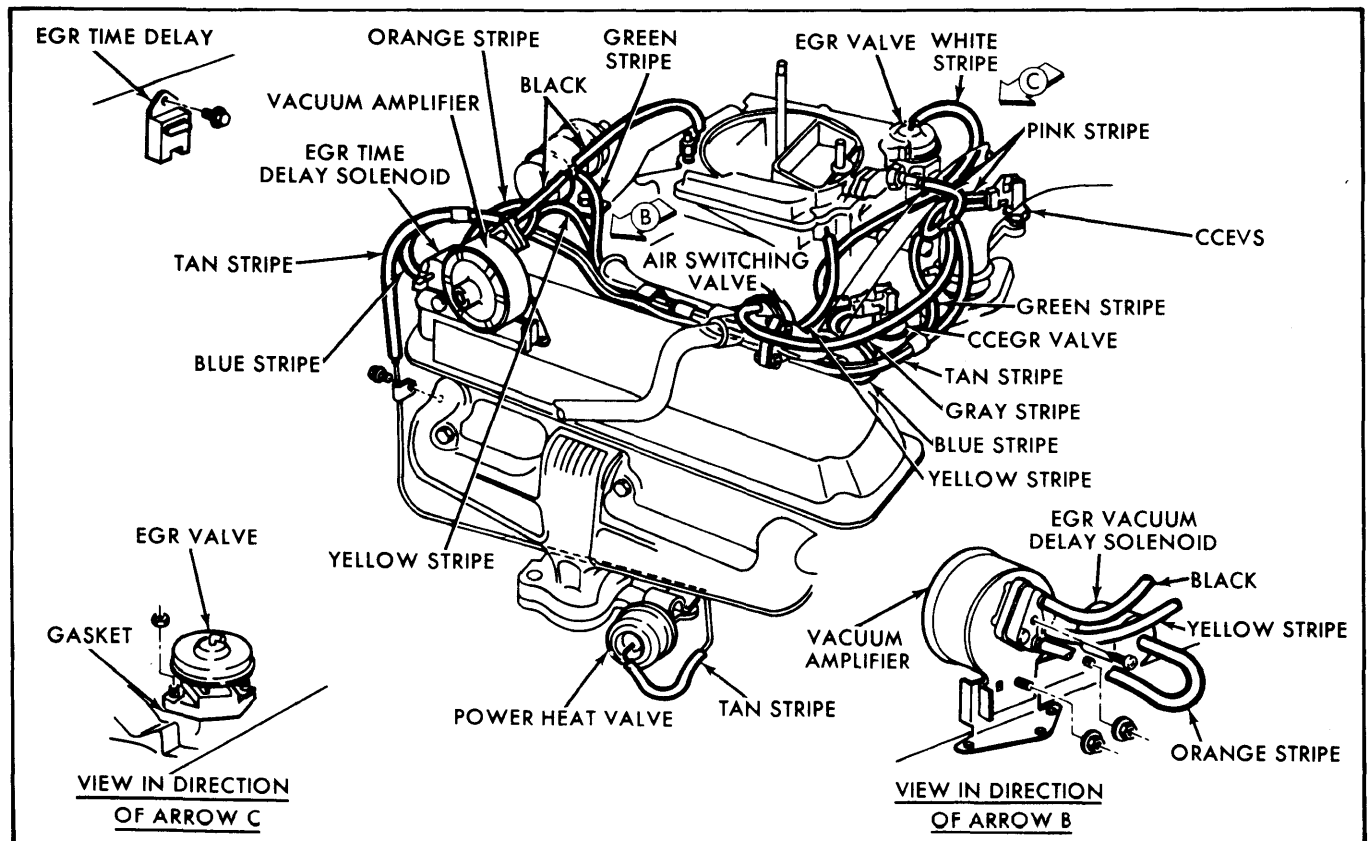

Fig. 8 EGR Vacuum Hose Routing for 360 CID with 4-Bbl. & Auto. Trans. (Calif.)

# 1977 EXHAUST EMISSION SYSTEMS Chrysler Corp. Vacuum Diagrams (Cont.)

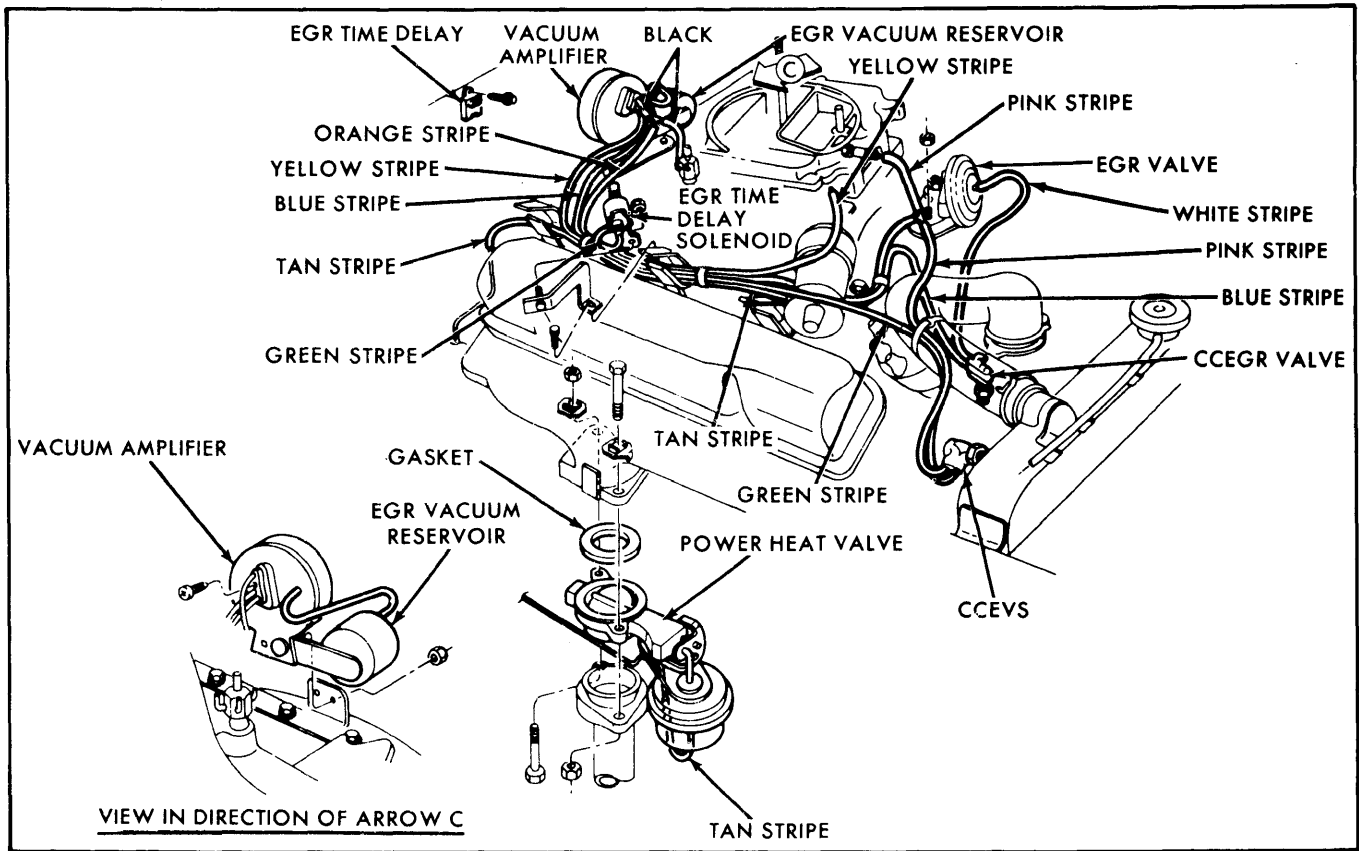

Fig. 9 EGR Vacuum Hose Routing for 440 CID with 4-Bbl.  
(Calif. - Exc. Fury & Monaco)

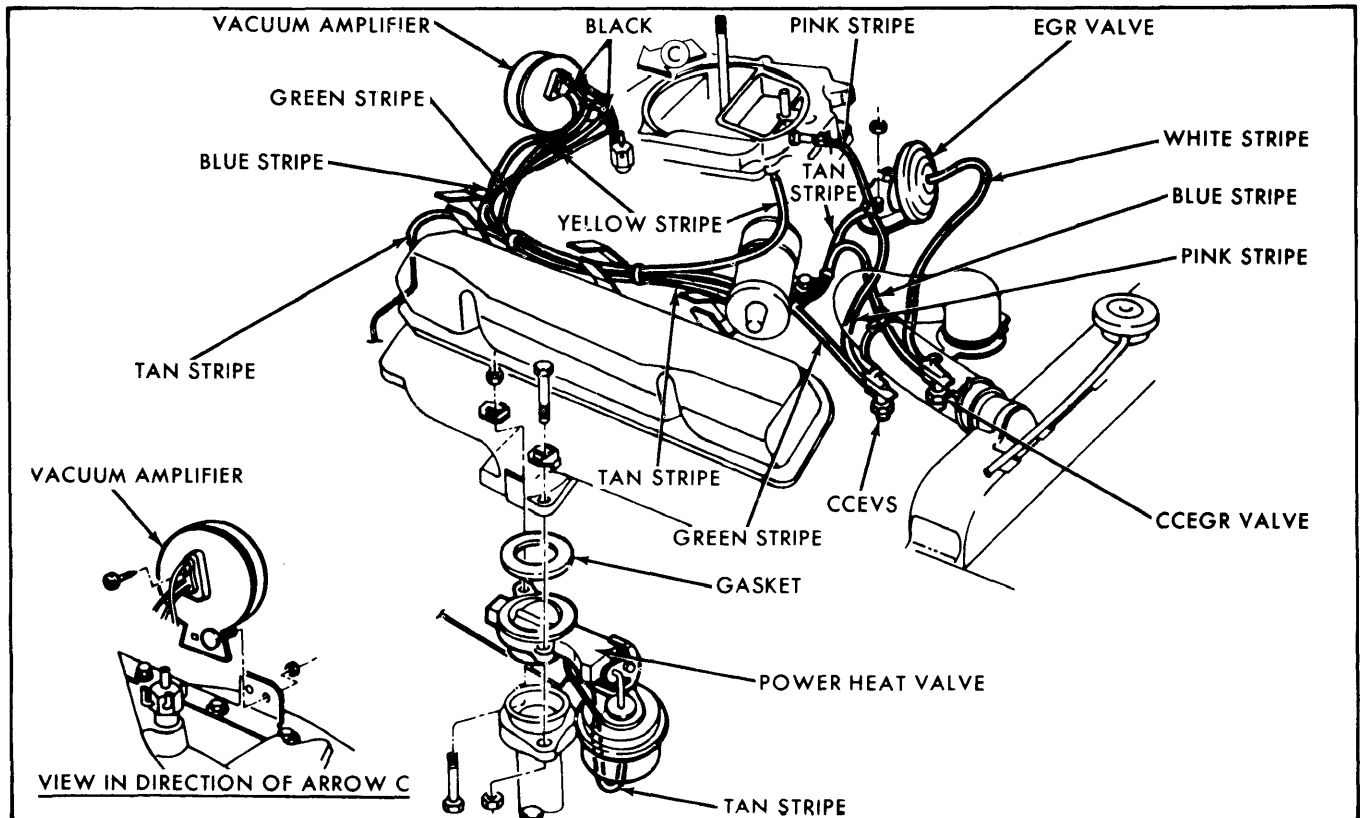

Fig. 10 EGR Vacuum Hose Routing with 440 CID with 4-Bbl.  
(Calif. - Fury & Monaco)

# 1977 EXHAUST EMISSION SYSTEMS Chrysler Corp. Vacuum Diagrams (Cont.)

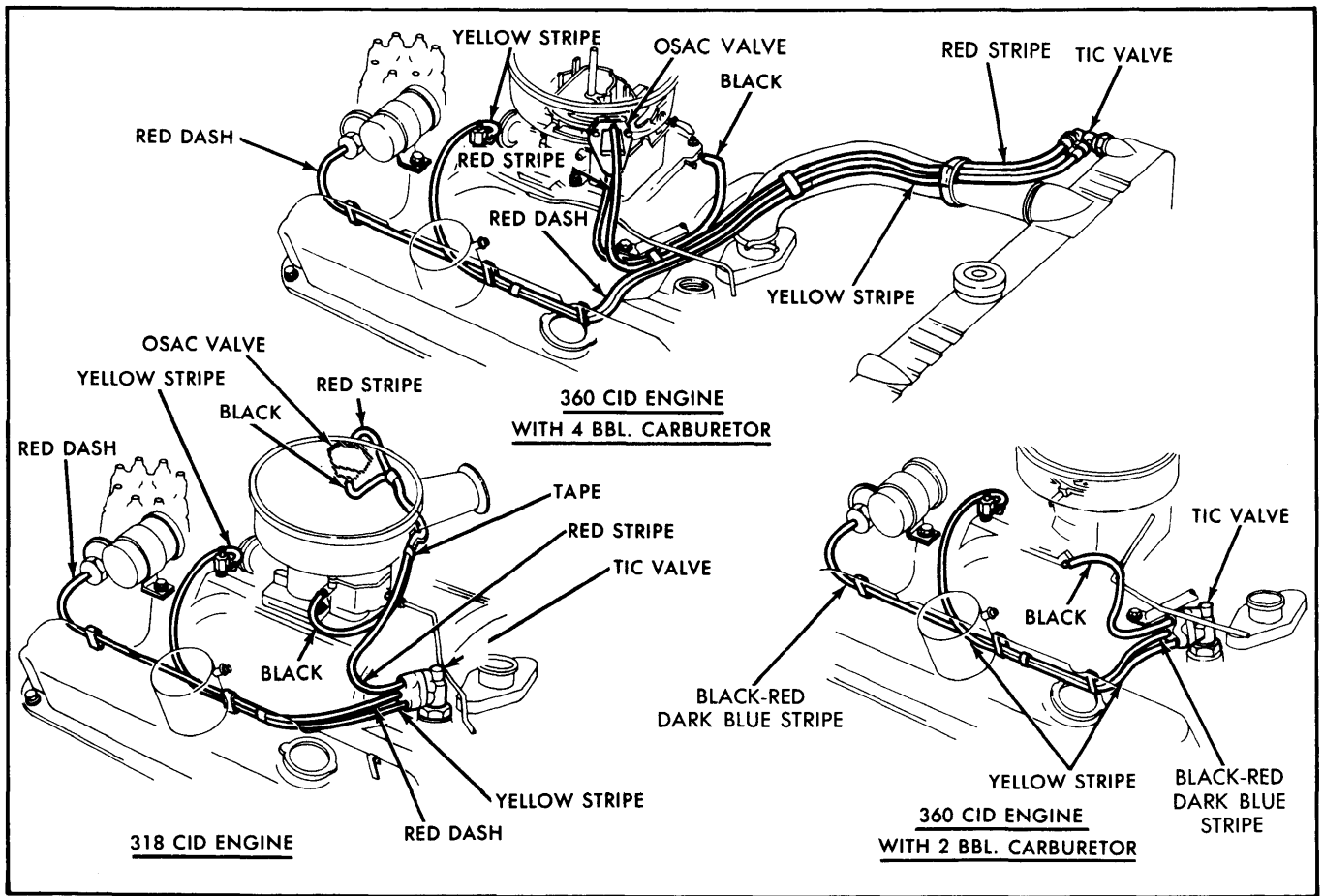

Fig. 11 Thermal Ignition Control (TIC) Valve Hose Routing (318 & 360")

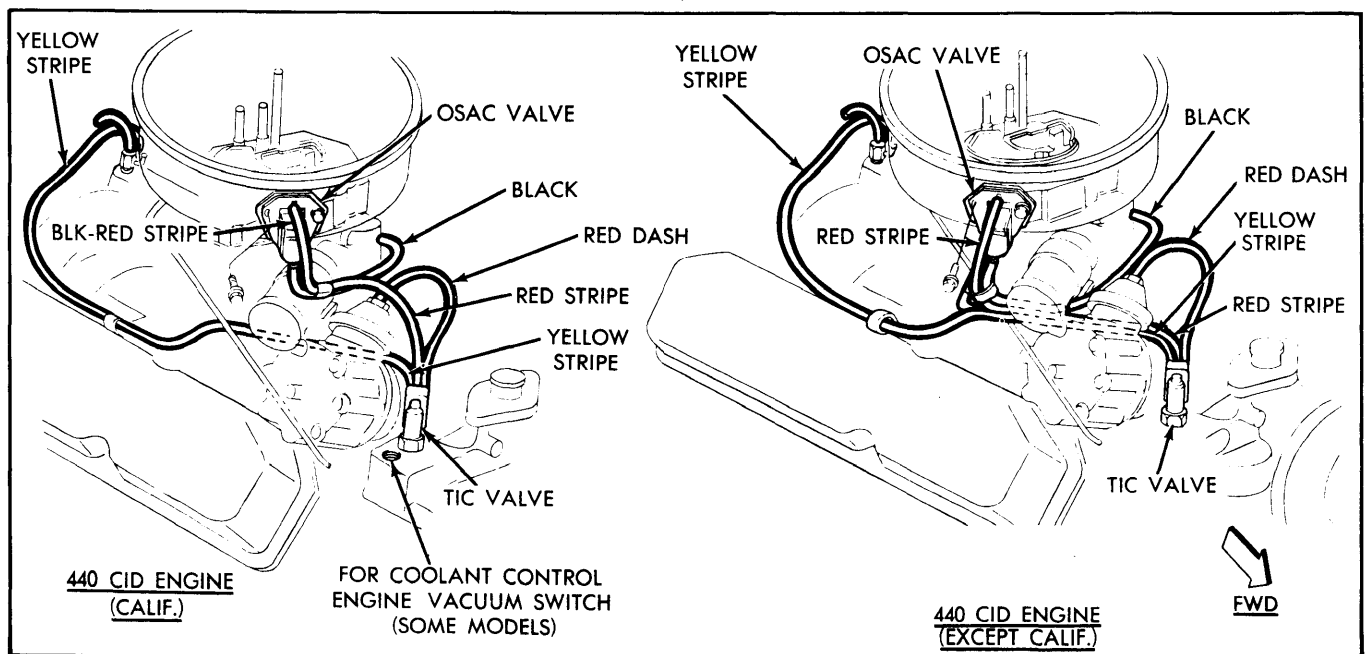

Fig. 12 Thermal Ignition Control (TIC) Valve Hose Routing (440")

# 1977 EXHAUST EMISSION SYSTEMS Chrysler Corp. Vacuum Diagrams (Cont.)

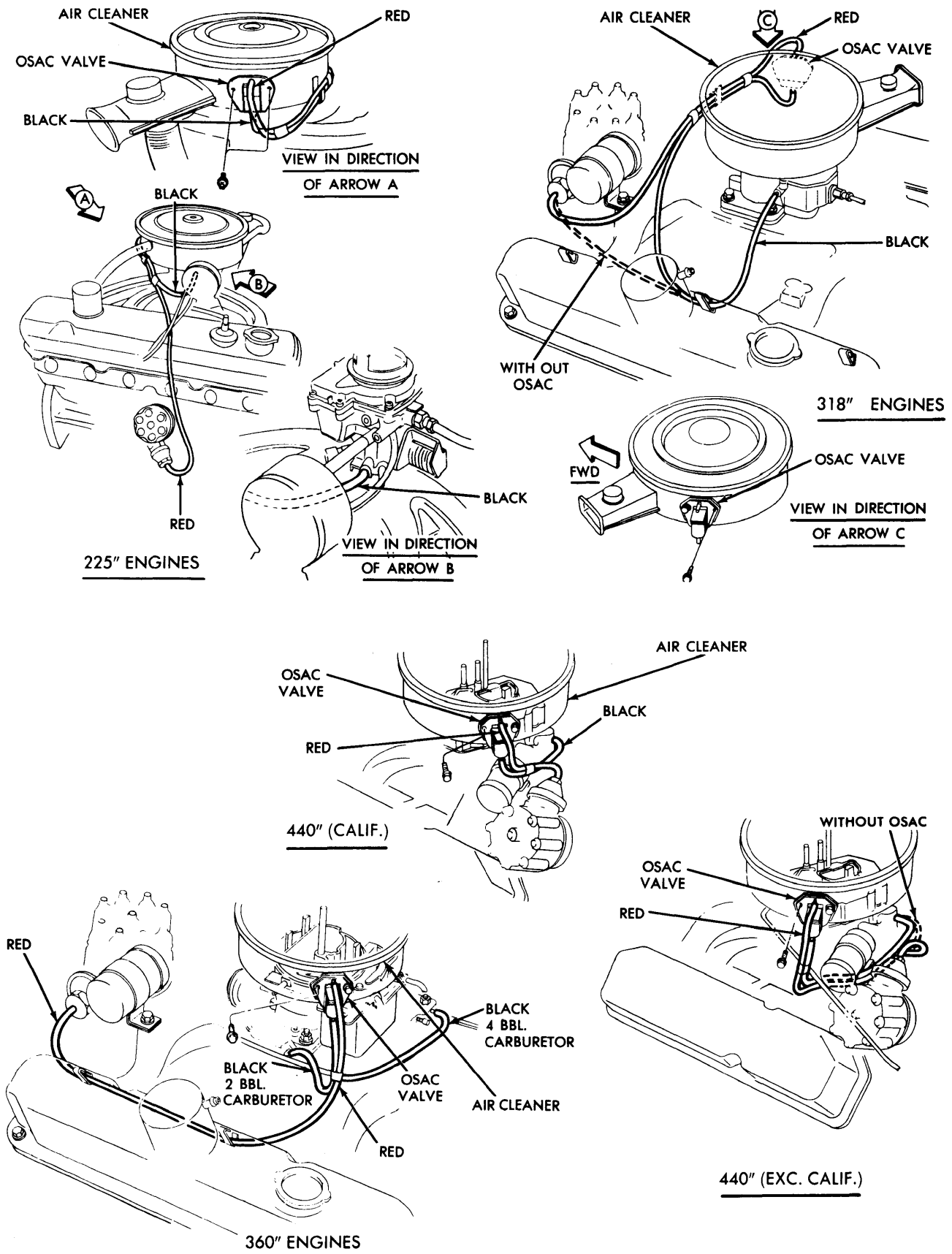
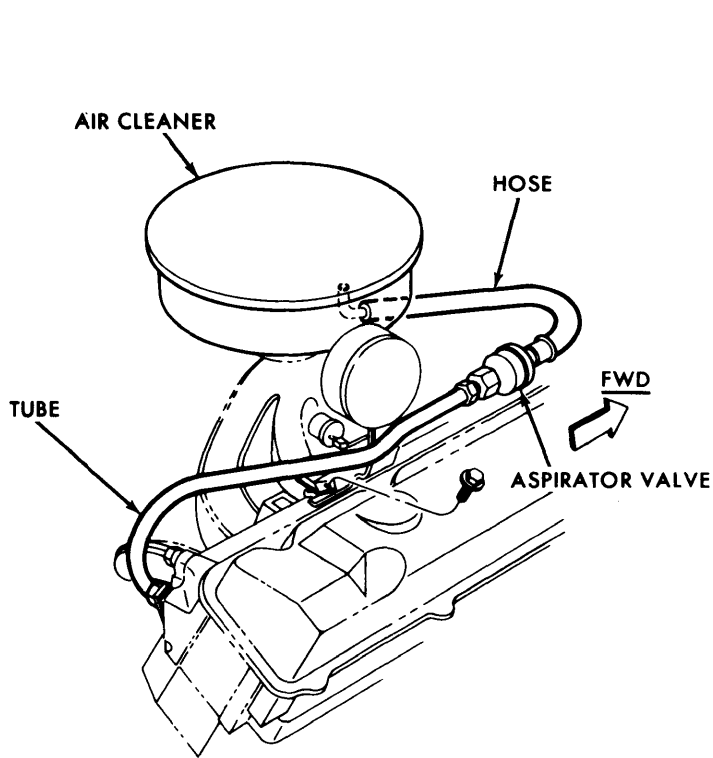
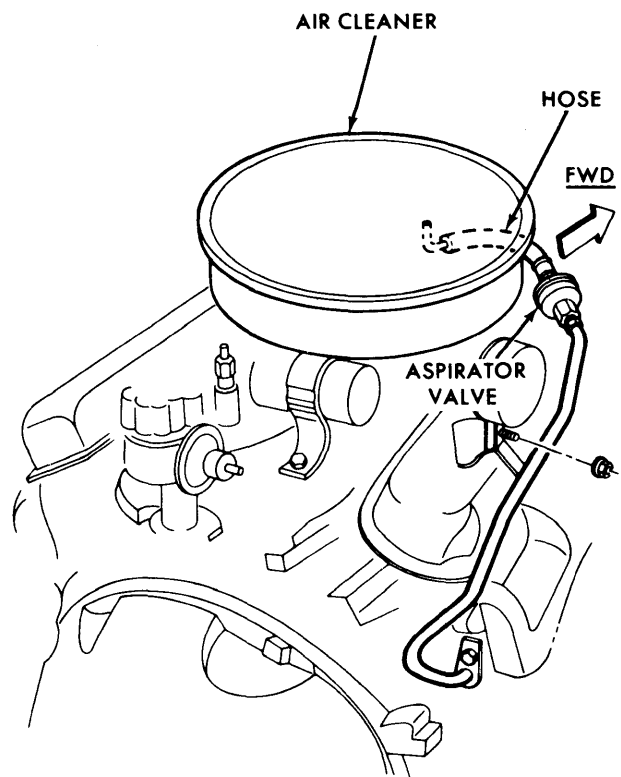

Fig. 13 OSAC Valve Vacuum Hose Routings (All Engines Shown)

# 1977 EXHAUST EMISSION SYSTEMS Chrysler Corp. Vacuum Diagrams (Cont.)



225 CID ENGINE



318-360 CID ENGINES

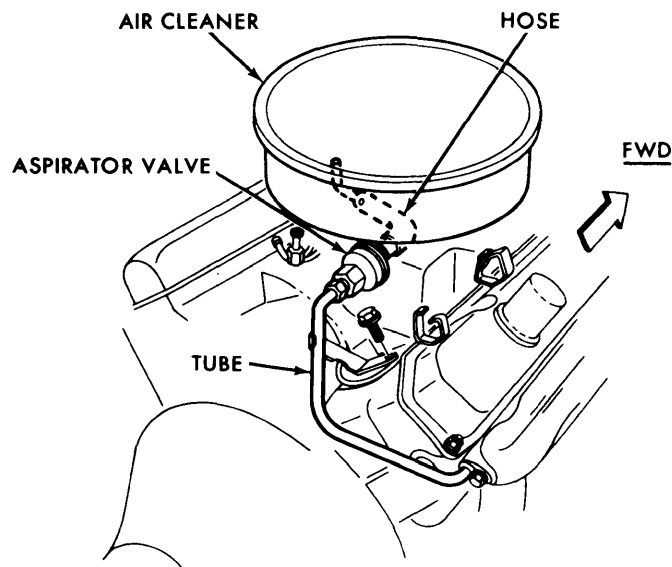

400-440 CID ENGINES

Fig. 14 Vacuum Hose Routings for Aspirator Air System