

1975-79 EXHAUST EMISSION SYSTEMS

Chrysler Corp. Air Injection System

3-79

1978-79 Chrysler Corp.

DESCRIPTION

The Air Injection System adds a controlled amount of air to exhaust gases in the exhaust ports, causing oxidation of the gases and a reduction in carbon monoxide and hydrocarbon emissions. System consists of a belt driven air pump, a combination diverter-pressure relief valve, a switching valve (except Omni and Horizon), rubber hoses, check valves to protect the hoses and other components from hot gases, and injection tubes.

NOTE: For information on 1975-77 Chrysler Corp. vehicles with Air Injection, see AIR INJECTION SYSTEMS - EXC. FORD WITH CAT. CONVERTER article in this section.

NOTE: Federal models use the Aspirator Air System in place of the Air Injection System described in this article. See CHRYSLER CORP. ASPIRATOR AIR SYSTEM article in this section.

OPERATION

AIR PUMP

The belt driven air pump is mounted on the front of the engine. Intake air enters the pump through a centrifugal filter fan at front of pump on all models except Omni and Horizon. On Omni and Horizon, intake air enters pump through a tube at the rear of pump.

CAUTION: On Omni and Horizon, the intake tube at rear of pump is larger in diameter than the discharge tube. If air hoses are not properly connected air pump may be damaged.

Air is delivered to the air injection manifold and check valve tube assembly by a rubber hose through the diverter valve and switching valve (except Omni and Horizon).

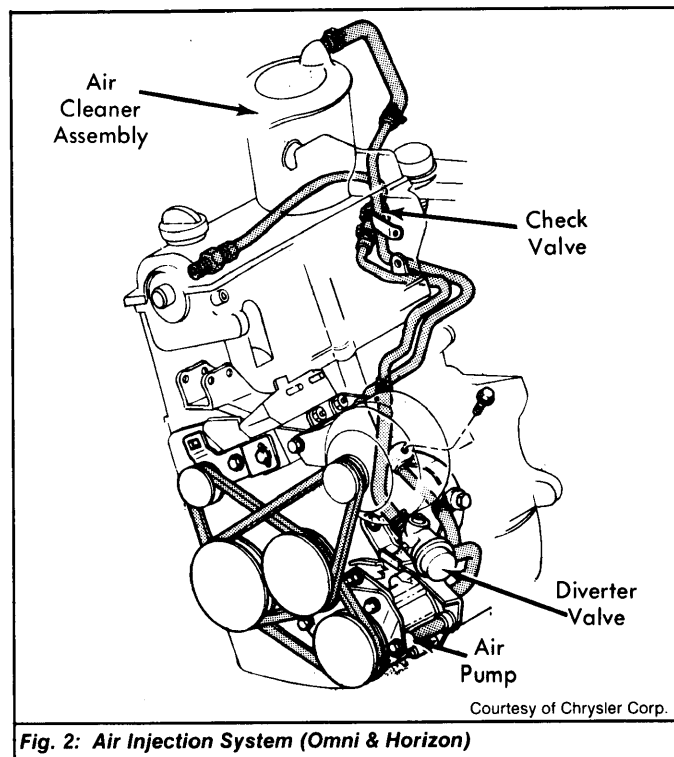

Fig. 2: Air Injection System (Omni & Horizon)

NOTE: The only serviceable component of the air pump is the centrifugal fan filter. Also, a color coded label applied to the under side of the air pump is used to identify the pump.

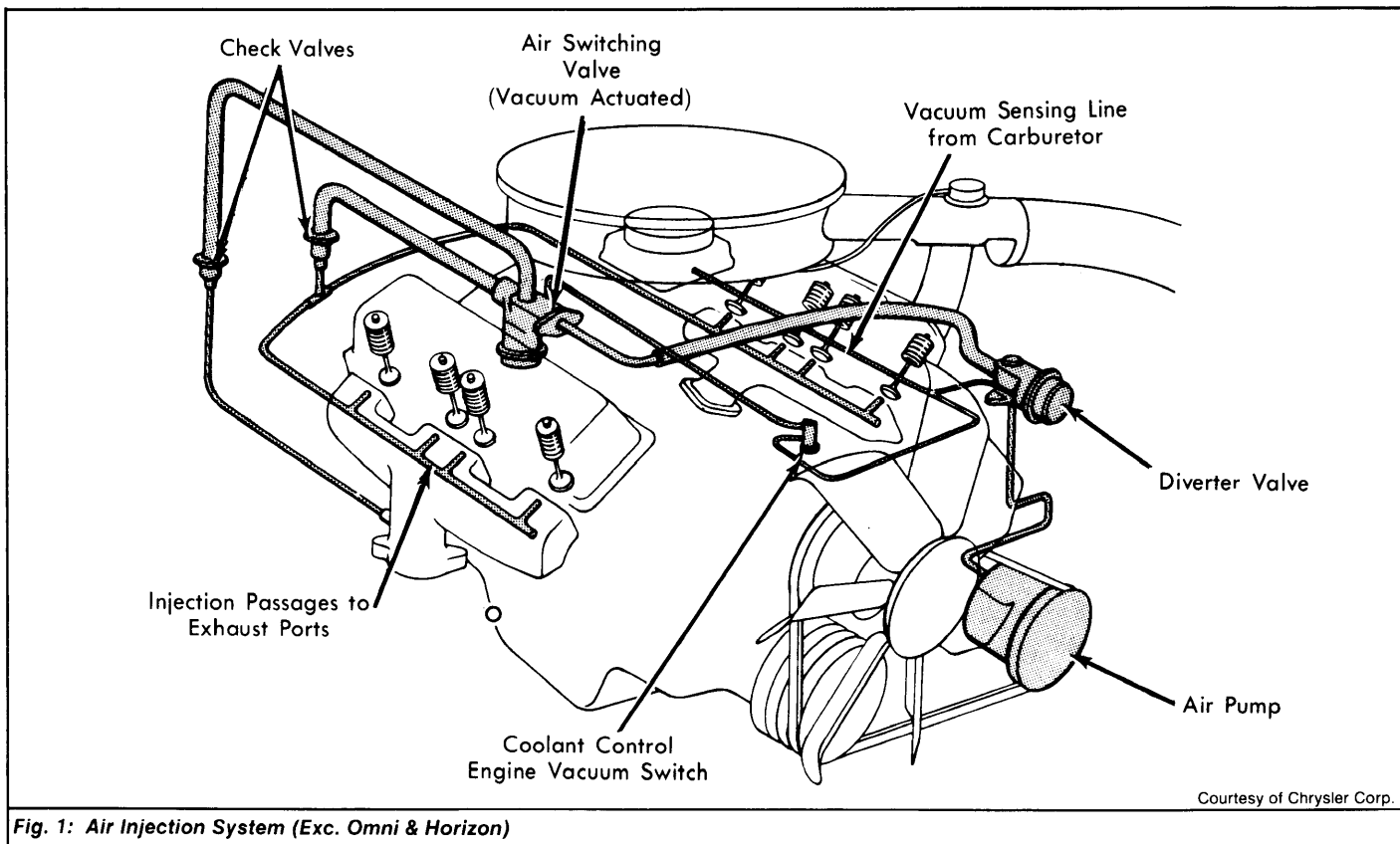

Fig. 1: Air Injection System (Exc. Omni & Horizon)

1975-79 EXHAUST EMISSION SYSTEMS

Chrysler Corp. Air Injection System (Cont.)

CAUTION: DO NOT LUBRICATE PUMP. Wipe all oil off of pump housing. Oil in the pump will cause rapid deterioration and failure.

DIVERTER VALVE

The purpose of the diverter valve is to prevent backfire in the exhaust system during sudden deceleration. The valve senses sudden increase in the intake manifold vacuum causing the valve to open, allowing air from the pump to pass through the valve and silencer to the atmosphere.

A pressure relief valve, incorporated in the diverter valve housing, controls, pressure within the system by diverting excessive pump output at higher engine speeds to the atmosphere through the silencer.

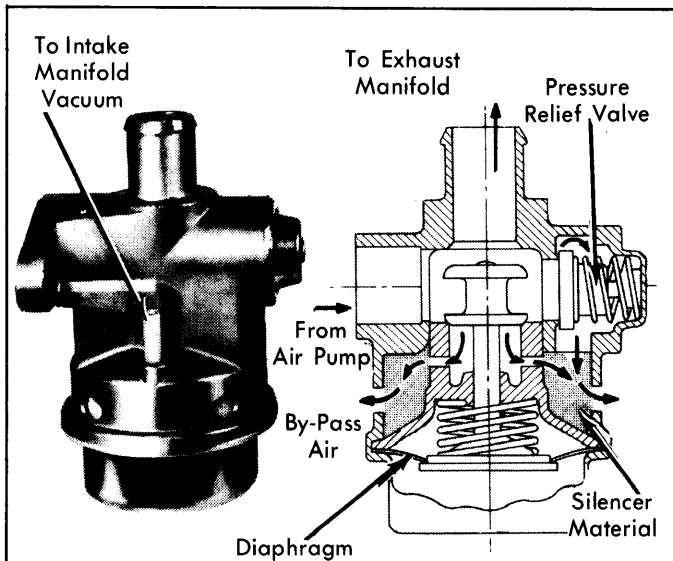

Courtesy of Chrysler Corp.

Fig. 3: Cutaway View of Diverter Valve

AIR SWITCHING VALVE

Not used on Omni and Horizon, the purpose of this valve is to switch the injection air from the exhaust ports to a point downstream after engine warmup. This prevents the air injection system from interfering with the operation of the exhaust gas recirculation system.

A vacuum signal from the Coolant Control Engine Vacuum Switch (CCEVS) causes the switching valve to open, allowing all air pump air to flow to the exhaust ports. When the CCEVS shuts off the vacuum signal to the switching valve, the valve closes, by-passing most of the air pump air to the injection point downstream. A bleed hole in switching valve allows a small percentage of air pump air to be injected at the exhaust ports at all times which assist in reduction of carbon monoxide and hydrocarbons.

The downstream location is in the exhaust pipe just behind the mini-catalyst on 6-cyl. engines and at the base of the right exhaust manifold, above the power heat control valve, on V8 engines.

CHECK VALVE

This valve is located in injection tube assemblies that lead to exhaust manifold. Valve has a one-way diaphragm which prevents hot exhaust gases from backing up into hose and pump. This valve will protect system in event of pump belt failure, abnormally high exhaust system pressure or air hose rupture.

POWER HEAT CONTROL VALVE

Used on all except Omni and Horizon, this valve is located between right exhaust manifold and exhaust pipe. It is a vacuum-operated device which responds to Coolant Controlled Engine Vacuum Switch (CCEVS) and directs most exhaust gas flow through left exhaust manifold during cold start conditions, to help bring the mini catalyst quickly up to operating temperature. At normal temperature, engine coolant switch is open and no vacuum signal is applied to power heat control valve. Exhaust gases are evenly distributed to right and left manifolds.

TESTING

DIVERTER VALVE

Check valve by accelerating engine and allowing throttle to close rapidly. A momentary rush of air should be noted at diverter air outlet.

CHECK VALVE

To check operation of this valve, remove air supply hose from pump at distribution manifold. With engine operating, listen for exhaust leakage at check valve which is connected to distribution manifold.

POWER HEAT CONTROL VALVE

To test this valve, remove vacuum line from power heat control valve and apply 6 in. Hg vacuum to valve. Valve should be fully closed. If not, replace valve.

SERVICE PROCEDURES

Complete system should be checked for proper operation at regular intervals. Condition of engine tune-up should be checked whenever air injection is not operating properly. On all air injection pumps, servicing is limited to replacement of the centrifugal fan filter (if equipped) or entire pump.

Centrifugal Fan Filter - To replace, remove drive belt, pulley mounting bolts, and pulley. Using needle nose pliers, break fan from hub, being careful that fragments do not enter air intake hole. Install new filter by drawing it on with the pulley and pulley bolts. Do not attempt to hammer or press filter onto hub.

NOTE: After new fan filter is installed, it may squeal during operation until its outside diameter has worn in. This may require 20 to 30 miles of operation.

CAUTION: If engine or engine compartment is to be cleaned with steam or high pressure detergent, centrifugal fan filter should be masked off to prevent liquids from entering air pump.