

1976 EXHAUST EMISSION SYSTEMS

American Motors Vacuum Diagrams

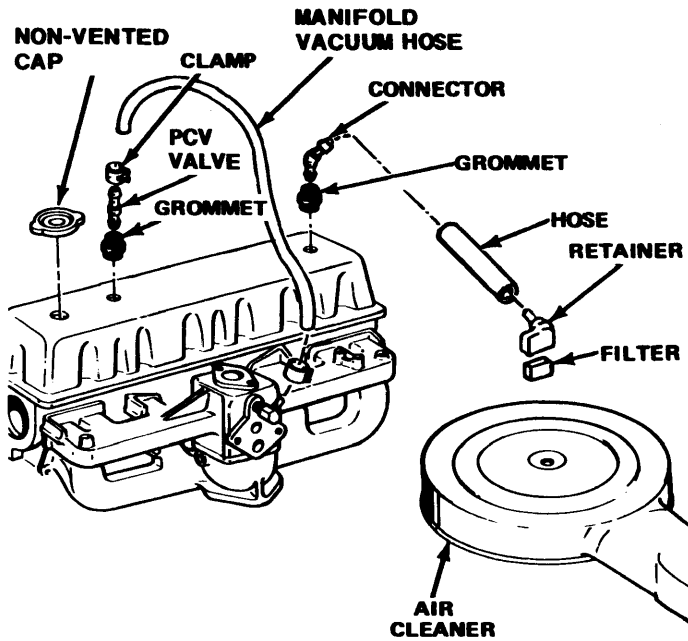

PCV SYSTEM (6 CYL.)

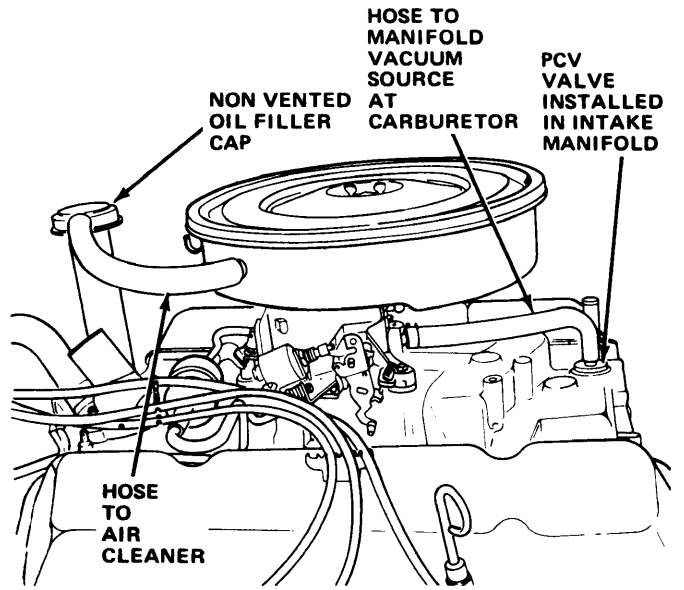

PCV SYSTEM (V8)

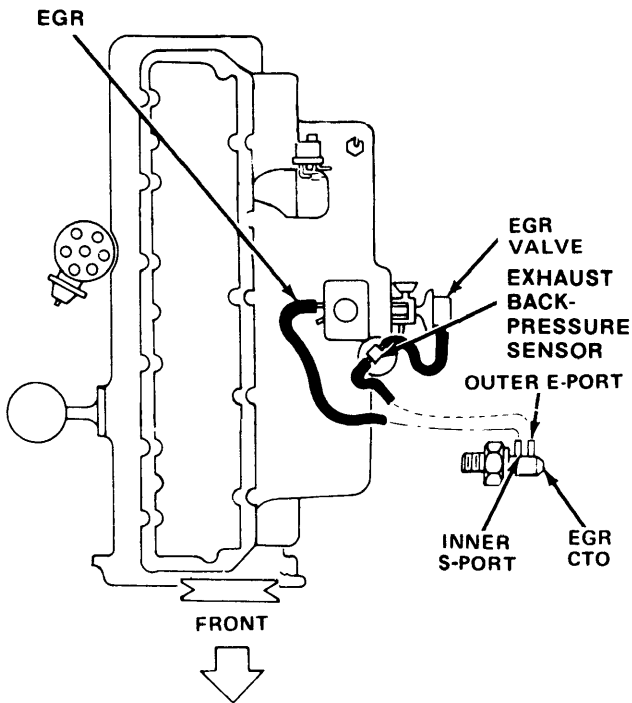

EGR SYSTEM (6 CYL.)

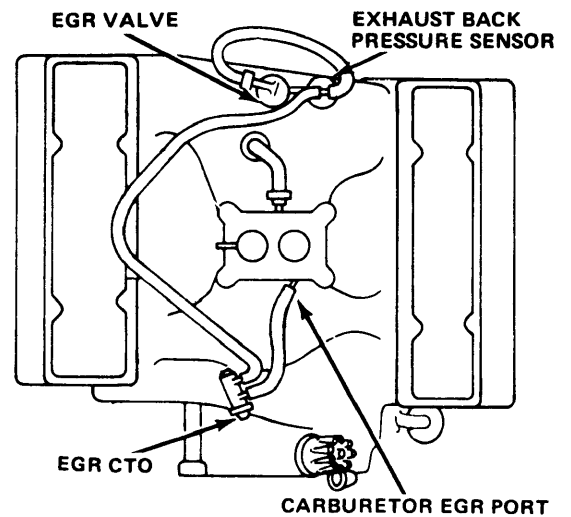

EGR SYSTEM (V8)

1976 EXHAUST EMISSION SYSTEMS

American Motors Vacuum Diagrams (Cont.)

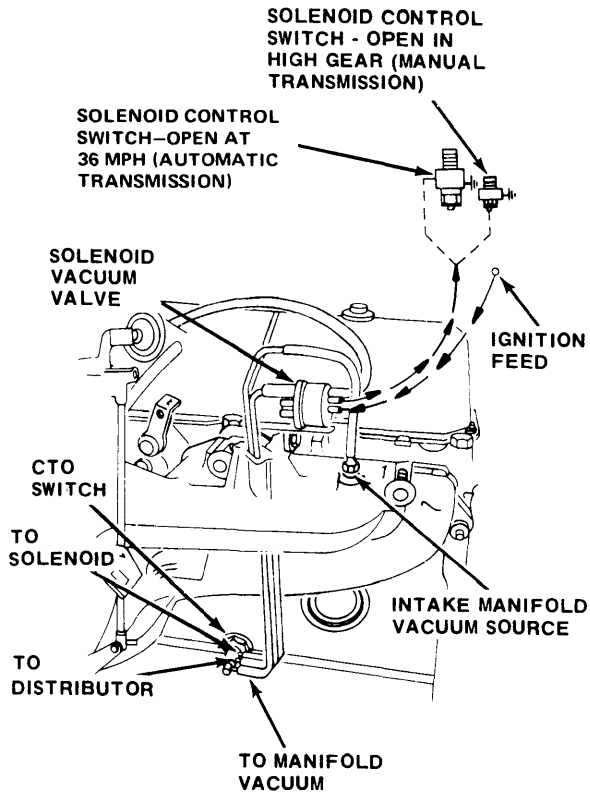

TCS SYSTEM (6-CYL.)

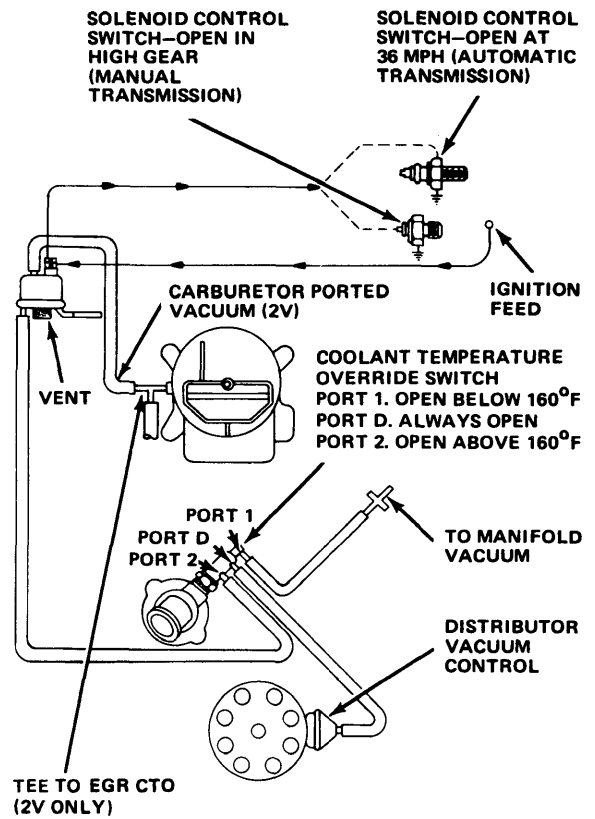

TCS SYSTEM (V8)

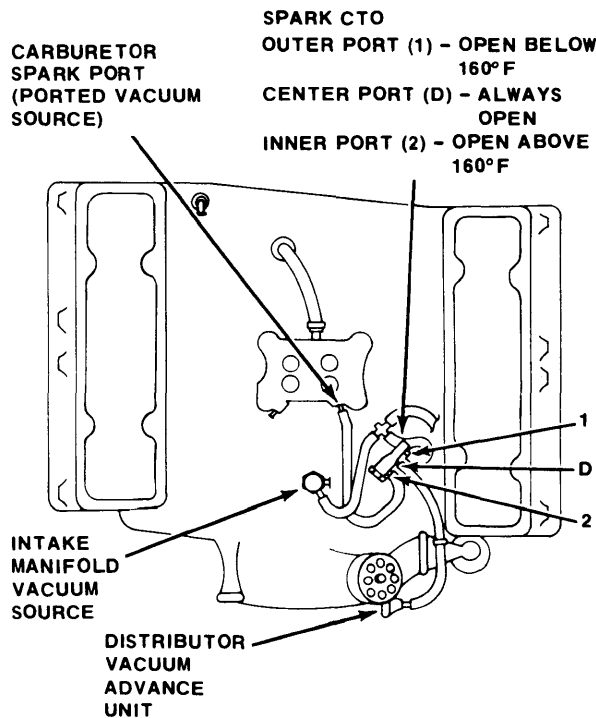

OPERATING CHARACTERISTICS

- A. BELOW 160°F - MANIFOLD VACUUM
- B. ABOVE 160°F - CARBURETOR PORTED

SPARK CTO SYSTEM (V8 FEDERAL)