

# 1975-79 FUEL SYSTEMS

## 2MC, E2ME, M2MC, M2MC-200 & M2ME 2-Barrel

### CARBURETOR APPLICATIONS

#### 1975 GENERAL MOTORS APPLICATIONS

Application	Rochester Carburetor No.	
	Man. Trans.	Auto. Trans.
Buick (260")		
Federal		
With A/C		7045156
Without A/C		7045298
Calif.		
With A/C		7045358
Without A/C		7045354
Oldsmobile & Pontiac (260")		
Federal		
With A/C	7045297	7045156
Without A/C	7045297	7045298
Calif.		
With A/C		7045356
Without A/C		7045598

#### 1976 GENERAL MOTORS APPLICATIONS

Application	Rochester Carburetor No.	
	Man. Trans.	Auto. Trans.
Buick 260" V8		
Skylark		
Federal W/AC	17056157	17056156
Federal W/O AC	17056157	17056158
Calif. W/AC <sup>1</sup>	17056457	17056468
Calif. W/O AC <sup>1</sup>	17056457	17056454
Calif. <sup>2</sup>	17056457	17056455
Oldsmobile 260" V8		
Cutlass & Omega		
Federal W/AC	17056157	17056156
Federal W/O AC	17056157	17056158
Cutlass <sup>1</sup>		
Calif. W/AC		17056456
Calif. W/O AC		17056459
Omega <sup>1</sup>		
Calif. W/AC	17056457	17056458
Calif. W/O AC	17056457	17056454
Cutlass & Omega <sup>2</sup>		
Calif.	<sup>3</sup> 17056457	17056454
Pontiac 260" V8		
LeMans & Ventura		
Federal W/AC	17056157	17056156
Federal W/O AC	17056157	17056158
LeMans <sup>1</sup>		
Calif. W/AC	17056457	17056456
Calif. W/O AC	17056457	17056459
Ventura <sup>1</sup>		
Calif. W/AC	17056457	17056458
Calif. W/O AC	17056457	17056454
LeMans & Ventura <sup>2</sup>		
Calif.	17056457	17056455

- <sup>1</sup> - Early production models.  
<sup>2</sup> - All late production models.  
<sup>3</sup> - Omega only.

#### 1977 GENERAL MOTORS APPLICATIONS

Application	Rochester Carburetor No.	
	Man. Trans.	Auto. Trans.
Buick 301" V8 (M2MC-200)		
Skylark, LeSabre & Estate Wagon		
Federal		17057172
Oldsmobile 260" V8 (2MC)		
Cutlass (Exc. Wagon), Omega & Delta 88		
Federal	17057157	<sup>1</sup> 17057150
		<sup>2</sup> 17057151
		<sup>1</sup> 17057156
		<sup>2</sup> 17057158
Pontiac 301" V8 (M2MC-200)		
All Models (Exc. Astre & Sunbird)		
Federal	17057173	17057172

<sup>1</sup> - With A/C  
<sup>2</sup> - Without A/C

#### 1978 GENERAL MOTORS APPLICATIONS

Application	Rochester Carburetor No.	
	Man. Trans.	Auto. Trans.
Buick		
Model M2MC		
301" V8 (VIN Y)		
All Models		17058160
Model M2ME		
231" V6 Turbo-charged (VIN G)		
All Models		17058192
		17058496
Chevrolet (M2ME)		
231" V6 (VIN A)		
Federal		17058182
305" V8 (VIN U)		
Federal	<sup>1</sup> <sup>3</sup> 17058131	<sup>2</sup> 17057130
	<sup>1</sup> 17058133	<sup>1</sup> 17058131
		17058132
Oldsmobile (M2MC)		
260" V8 (VIN F)		
Federal	17058151	<sup>1</sup> <sup>4</sup> 17058150
		<sup>2</sup> 17058152
		<sup>1</sup> 17058156
		<sup>2</sup> 17058158
Calif.		17058450
High Altitude		<sup>1</sup> 17058154
		17058155
Pontiac (M2MC)		
301" V8 (VIN Y)		
Federal		17058160

<sup>1</sup> - With A/C.  
<sup>2</sup> - Without A/C.  
<sup>3</sup> - Malibu models only.  
<sup>4</sup> - Non A/C with H.D. Cooling system.

# 1975-79 FUEL SYSTEMS

## 2MC, E2ME, M2MC, M2MC-200 & M2ME 2-Barrel (Cont.)

### 1979 GENERAL MOTORS APPLICATIONS

Application	Rochester Carburetor No.	
	Man. Trans.	Auto. Trans.
196" V6 (Model M2ME)		
Federal		
Without A/C .....	17059193	17059194
With A/C .....	17059193	17059184
200" V6 (Model M2ME)		
Federal		
Without A/C .....	17059131	17079130
With A/C .....	17059133	17059132
231" V6 (Model E2ME)		
Calif. ....		17059196
231" V6 (Model M2ME)		
Federal		
Without A/C .....	17059191	17059190
With A/C .....	17059191	17059180
Calif. ....	17059491	17059492, 9498
High Alt. ....		17059196
260" V8 (Model M2MC)		
Federal		
Without A/C .....	17059151	17059150
With A/C .....	17059151	17059152
Calif. ....		17059450
High Alt. ....		17059154
267" V8 (Model M2MC)		
Federal		
Without A/C .....	17059139	17059138
With A/C .....	17059141	17059140
301" V8 (Model M2MC)		
Federal .....		17059160
305" V8 (Model M2MC)		
Federal		
Without A/C .....	17059135	17059134
With A/C .....	17059137	17059136
Calif.		
Without A/C .....		17059430
With A/C .....		17059432

### CARBURETOR IDENTIFICATION

The carburetor numbers are stamped vertically on the left rear corner of the float bowl. If float bowl is replaced, follow manufacturer's instructions contained in service package to transfer part number to new float bowl.

### DESCRIPTION

The Rochester Dualjet carburetor models 2MC, E2ME, M2MC, M2MC-200 and M2ME are a single-stage, 2-barrel downdraft carburetor. Each bore has a separate and independent idle circuit.

Most models of this carburetor use 2 tapered metering rods located in the metering jets to control the main fuel mixture. These metering rods are operated by manifold vacuum. On the M2MC-200 model carburetor, the metering rods are also operated by a lever off of the throttle shaft rod.

All E2ME models are equipped with an electrically operated mixture control solenoid. The mixture control solenoid, mounted in the fuel bowl, controls air and fuel metered to the idle and main metering systems. Fuel metering is controlled by 2 special stepped metering rods, operating in fixed jets, positioned by a plunger in the mixture control solenoid.

All carburetors are equipped with a front vacuum break with a leaf-type bucking spring. Some models may use both a front and rear vacuum break to control choke valve openings during initial engine starting and cold driveaway.

**NOTE:** This article covers operations related to on-bench type of adjustments. If on-vehicle adjustments (including mixture control solenoid adjustments) are required, see appropriate TUNE-UP article in TUNE-UP PROCEDURES section. On E2ME carburetors with feedback mixture control, if problems are still present after overhaul, or replacement of the air horn, float bowl or throttle body, or on-vehicle adjustments are performed, see GENERAL MOTORS COMPUTER-CONTROL CATALYTIC CONVERTER article in COMPUTERIZED ENGINE CONTROLS section.

### ADJUSTMENTS

**NOTE:** For all on-vehicle adjustments (including mixture control solenoid) not covered in this article, see appropriate article in TUNE-UP PROCEDURES section.

### ANGLE GAUGE ADJUSTMENT TOOL

Manufacturer recommends that some carburetor adjustments on 1978-79 vehicles be performed using a choke valve angle gauge (J-26701). While preparations and actual adjustment may vary with each individual adjustment, the procedure for using the angle gauge to check the choke valve angle remains the same. Use the following procedure to perform adjustments requiring the use of the choke valve angle gauge.

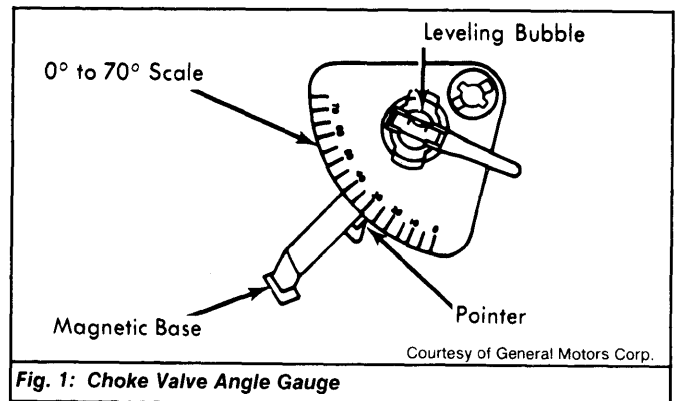

**Fig. 1: Choke Valve Angle Gauge**

- 1) Rotate degree scale on angle gauge so that 0° mark is opposite pointer.
- 2) With choke valve closed, place angle gauge magnet squarely on choke valve.
- 3) Rotate leveling bubble on angle gauge until it is centered.
- 4) Rotate degree scale until specified degree mark is opposite pointer.
- 5) Now perform individual adjustment preparation as outlined in the following carburetor adjustments requiring an angle gauge.
- 6) If bubble is centered, adjustment is correct. If not, adjust carburetor as outlined in adjustment procedure.

**NOTE:** The adjustment steps also include procedures for checking clearances without angle gauge tool. Both degrees and decimal specifications will be given in CARBURETOR ADJUSTMENT SPECIFICATIONS tables.

### FLOAT LEVEL

- 1) Remove air horn and gasket from float bowl. Hold float retainer down firmly. Lightly push float down against needle. See Fig. 2.
- 2) Position a "T" scale over toe of float at a point 1/16" on 1975-77 models or 3/16" on 1978-79 models from end of float toe. Measure distance from top of float bowl casting to top of float.
- 3) If float level setting varies more than 1/16" from specified setting, bend float on 1975-77 models, or proceed as follows on 1978-79 models:

# 1975-79 FUEL SYSTEMS

## 2MC, E2ME, M2MC, M2MC-200 & M2ME 2-Barrel (Cont.)

**Float Level Too High** – Hold float retainer clip firmly in place. Push down on center of float pontoon until correct float level setting is obtained.

**Float Level Too Low** – 1) Lift out metering rods. Remove mixture solenoid connector screws (if equipped). Turn lean mixture solenoid screw clockwise, counting and recording number of turns required to lightly seat screw in float bowl.

2) Turn screw counterclockwise and remove. Lift solenoid and connector from float bowl. Remove float and bend arm up to adjust. Make sure float is correctly aligned after adjustment. Reinstall components in reverse order that they were removed. Back out solenoid mixture screw number of turns noted in step 1).

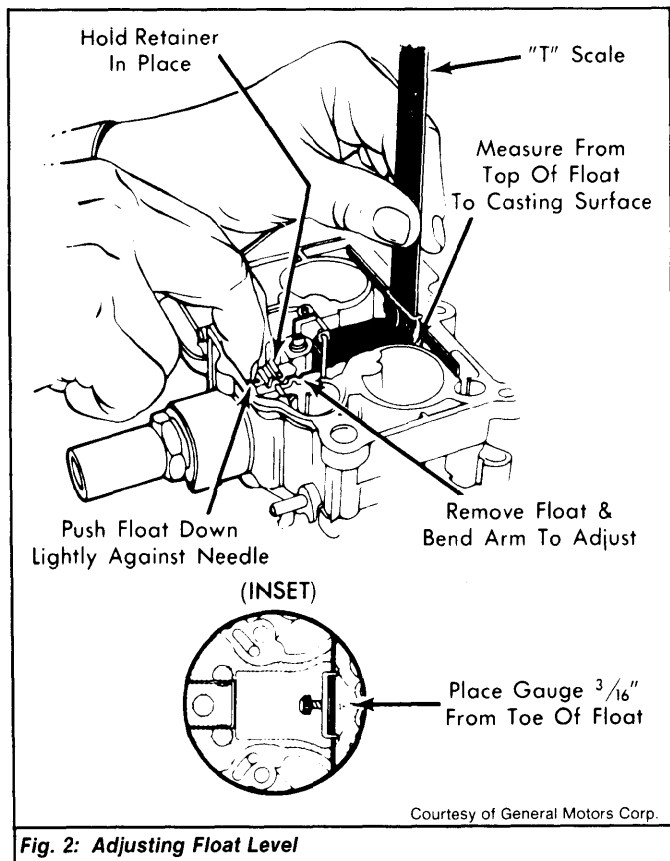

Fig. 2: Adjusting Float Level

**NOTE:** The following procedures are required to correctly adjust a E2ME carburetor. These adjustments include setting the maximum lean and maximum rich travel of the mixture control solenoid. The last 2 adjustments are to establish a base setting for the idle air bleed screw and the idle mixture adjustment screws. After these basic setting are made, the final adjustments must be performed on the vehicle with a CO meter and dwell meter.

### SOLENOID LEAN MIXTURE SCREW

**E2ME** – 1) Remove air horn, mixture control solenoid, air horn gasket and plastic block. If removed, install the following mixture control components. If already installed, go to step 5).

2) Install plastic aneroid cavity insert beneath mixture control solenoid connector in float bowl, if used. Ensure insert is installed with inset aligned with recess of bowl cavity and seated flush with bowl casting surface. Tang on upper lip of insert goes in deep slot in bowl closest to fuel inlet nut.

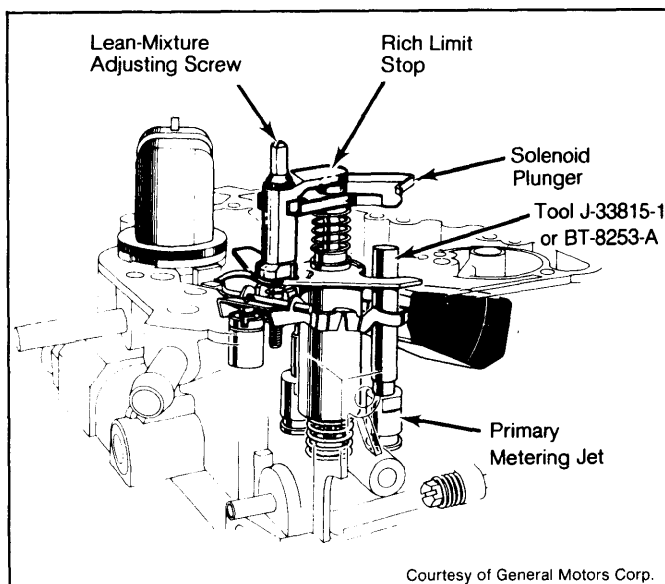

Fig. 3: Installing Lean Mixture Gauging Tool

3) Install mixture control solenoid screw tension spring between raised bosses next to float hanger pin. Carefully install mixture control solenoid in float chamber. Align pin on end of solenoid with hole in raised boss at bottom of bowl. Align connector wires to fit in slot in bowl or plastic insert, if used.

4) Install solenoid lean mixture screw through hole in solenoid bracket and tension spring in float bowl. The first 6 threads of the mixture screw should be engaged to assure proper installation. Lean mixture screw is close to adjustment if it is 2 turns out (from lightly seated position in float bowl).

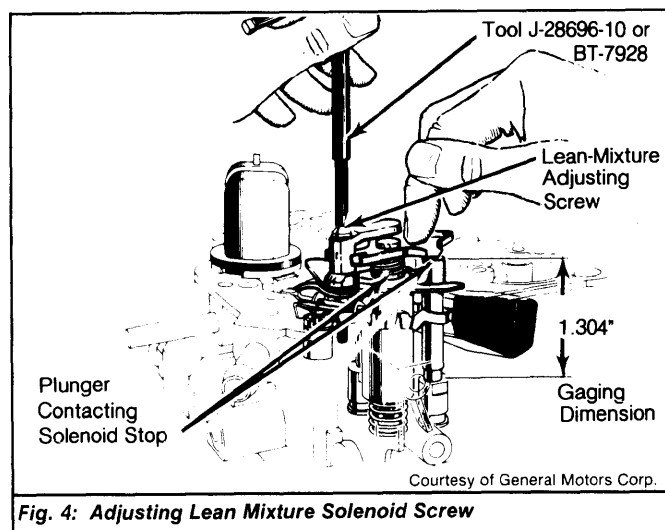

Fig. 4: Adjusting Lean Mixture Solenoid Screw

### SOLENOID RICH MIXTURE STOP SCREW

**E2ME** – 1) Ensure solenoid lean mixture screw is properly set and air horn installed. Remove lean mixture screw plug and rich mixture stop screw plugs from air horn. Insert plastic float gauge (J-9789-130 or BT-8106) in vertical "D" shaped vent hole in air horn casting.

2) With float gauge installed, read mark (in inches) on gauge that lines up with top of air horn casting at eye level. Record reading. Lightly depress float gauge and again read mark on gauge that lines up with top of casting. Record reading.

3) Subtract the 2 readings taken in step 2). This difference is the total solenoid travel. Using a "double D" wrench (J-28696-10 or BT-

# 1975-79 FUEL SYSTEMS

## 2MC, E2ME, M2MC, M2MC-200 & M2ME 2-Barrel (Cont.)

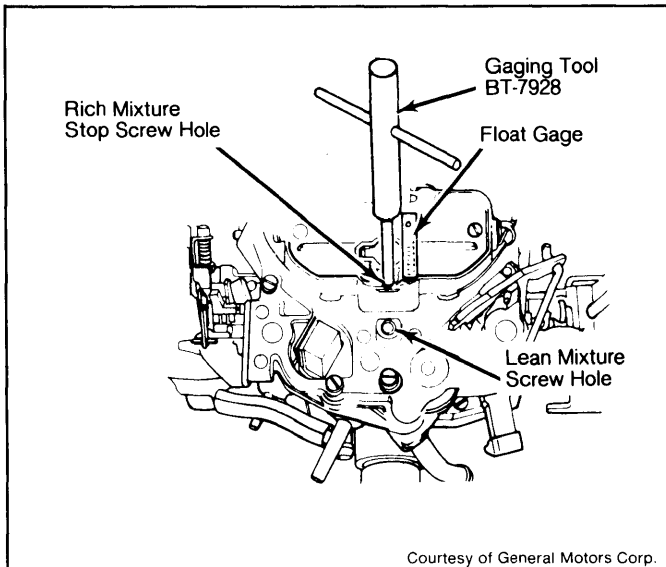

Fig. 5: Adjusting Solenoid Rich Mixture Stop Screw

7928), turn rich mixture stop screw until total solenoid travel (difference between readings) is  $4/32$ ". See Fig. 5.

4) After adjustment, install lean mixture screw plug and rich mixture stop screw plug. Plugs must be installed to seal settings and to prevent fuel vapor loss.

### IDLE AIR BLEED VALVE & IDLE MIXTURE SCREWS (E2ME ONLY)

**NOTE:** This is a bench adjustment only. It is made to ensure that mixture screws and idle air bleed valve are set close to specifications prior to final adjustment. Final adjustment must be made with carburetor installed and engine running. See appropriate article in TUNE-UP PROCEDURES section

1) With air horn properly installed, lightly seat mixture screws. Back out each screw 6 turns. Final adjustment is performed on-vehicle.

2) The idle air bleed valve is sealed with a riveted cover. This cover should not be removed unless required for cleaning, part replacement, improper dwell readings, or if System Performance Check Chart of GENERAL MOTORS COMPUTER-CONTROL CATALYTIC

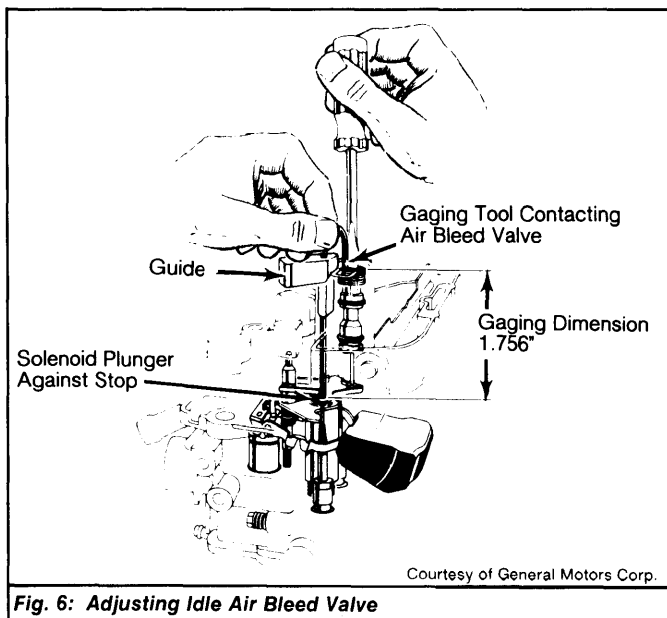

Fig. 6: Adjusting Idle Air Bleed Valve

CONVERTER article in COMPUTERIZED ENGINE CONTROLS section indicates that carburetor requires adjustment.

3) If idle air bleed cover was previously removed, or if conditions described in step 2) are met, go to next step. If necessary, carefully drill out rivets. Remove idle air bleed cover.

4) To adjust idle air bleed valve, insert air bleed valve gauging tool (J-33815-2 or BT-8253-B) in throttle side "D" shaped vent hole in air horn casting. Upper end of tool should be positioned over open cavity next to valve. See Fig. 6.

5) Hold the gauging tool down lightly so solenoid plunger is against solenoid stop. Adjust air bleed valve so gauging tool will pivot over and just contact top of valve. See Fig. 6. To finish adjustments, see MIXTURE ADJUSTMENTS in appropriate TUNE-UP PROCEDURES article.

### ACCELERATOR PUMP

1) Close throttles completely. Ensure fast idle speed screw is off fast idle cam and accelerator pump rod is in specified hole.

2) Using a "T" scale, measure distance from top of accelerator pump rod stem to top of choke valve wall. To adjust, support pump lever arm and bend at point indicated. See Fig. 7.

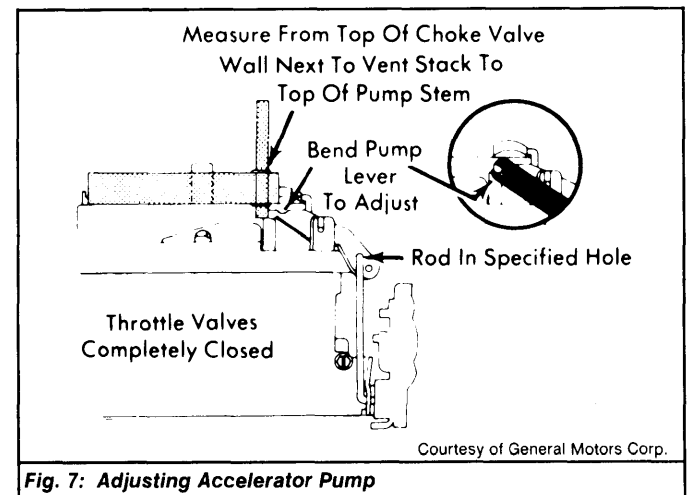

Fig. 7: Adjusting Accelerator Pump

### CHOKE COIL LEVER

1) Remove retaining screws or rivets (if equipped). Remove choke cover and coil assembly from choke housing.

2) Position fast idle speed cam follower on high step of fast idle cam. Push up (counterclockwise) on choke coil tang to close choke valve.

4) Insert specified drill or pin gauge in hole provided in choke housing. Lower edge of choke lever inside housing should just touch drill or pin gauge.

5) To adjust, bend choke rod. See Fig. 8.

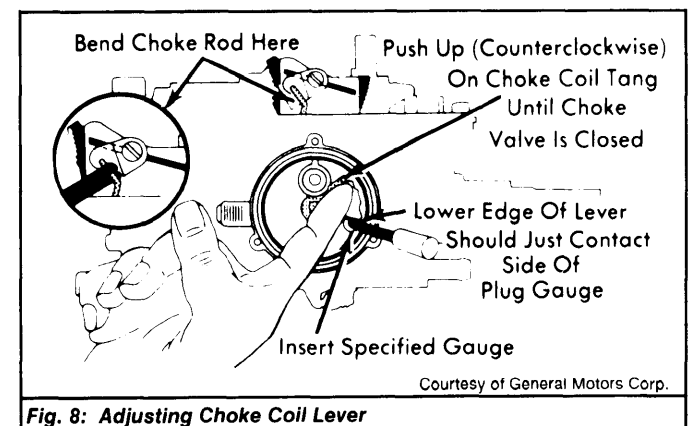

Fig. 8: Adjusting Choke Coil Lever

# 1975-79 FUEL SYSTEMS

## 2MC, E2ME, M2MC, M2MC-200 & M2ME 2-Barrel (Cont.)

### CHOKE ROD (FAST IDLE CAM)

**NOTE:** Choke coil lever adjustment must be correct before performing this adjustment. Fast idle speed adjustment must be performed using the Emission Control Tune-Up Decal with carburetor installed and vehicle running. Adjustment is performed with choke valve angle gauge. See procedure at beginning of ADJUSTMENTS. Do not remove rivets and choke cover to perform this adjustment.

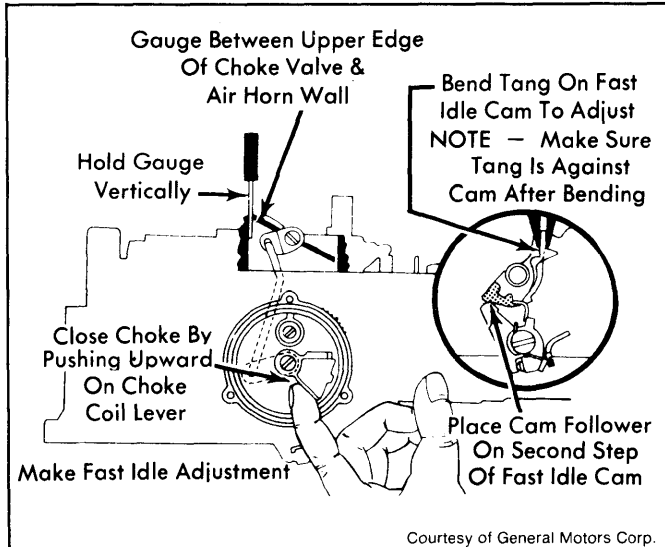

Fig. 9: 1975-77 Choke Rod (Fast Idle Cam) Adjustment

- 1) Attach rubber band to Green tang of intermediate choke shaft. Open throttle to allow choke valve to close. Set up angle gauge (if available).
- 2) Place fast idle speed cam follower on second step of fast idle cam against shoulder of highest step. If cam follower does not contact cam, turn in fast idle speed screw additional turns.
- 3) Bubble on choke angle gauge should be centered with specified angle mark opposite pointer. See Fig. 10. If angle gauge is not used, insert specified gauge between upper edge of choke valve and air horn wall. See Fig. 9.
- 4) To adjust, bend tang on fast idle cam until bubble of choke valve angle gauge is centered.

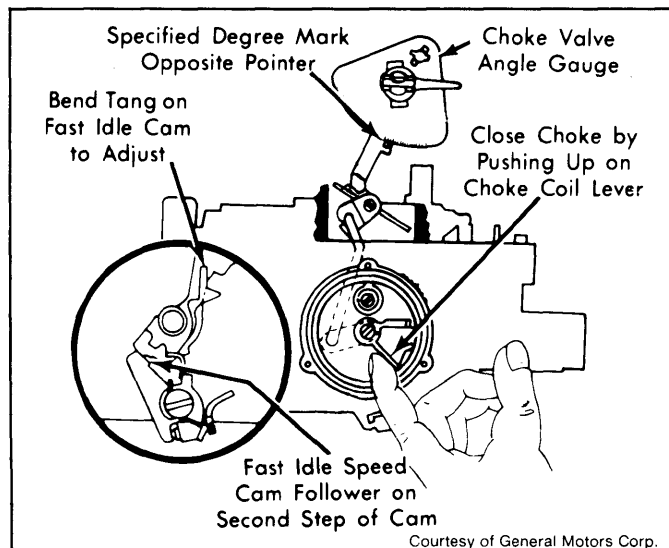

Fig. 10: 1978-79 Choke Rod (Fast Idle Cam) Adjustment

### VACUUM DIAPHRAGMS (2MC ONLY)

**Rich Setting Adjustment** - 1) Place cam follower on highest step of fast idle cam. Push back rubber cap on diaphragm and cover bleeder (if equipped).

**NOTE:** On models equipped with air bleed, remove rubber cover from filter and plug vacuum tube with a piece of tape. If bleed hole is in end of diaphragm, plug hole in end of diaphragm with a piece of tape. Remove tape after completing adjustment.

- 2) Seat diaphragm using outside vacuum source. Remove choke cover and push inside choke coil lever counterclockwise until tang on outside lever contacts vacuum break rod.
- 3) Ensure bucking spring is compressed. Insert specified gauge between upper edge of choke plate and air horn wall. If necessary, bend lower end of rod to adjust. See Fig. 11.

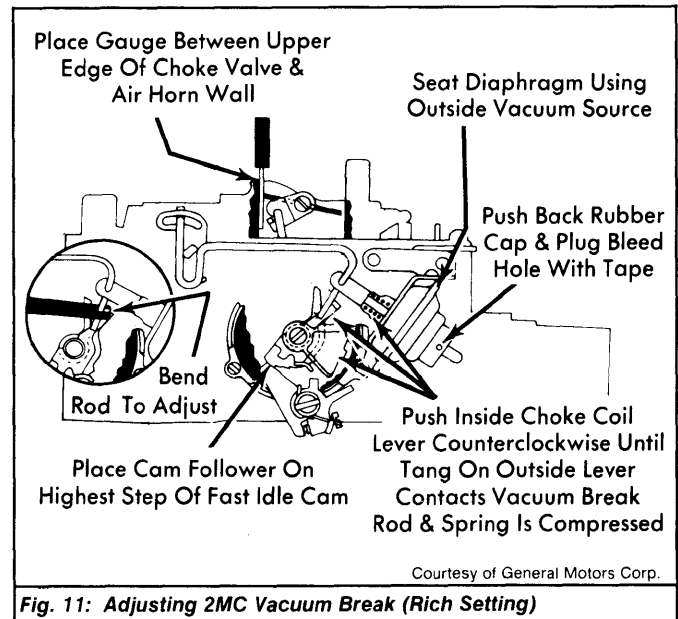

Fig. 11: Adjusting 2MC Vacuum Break (Rich Setting)

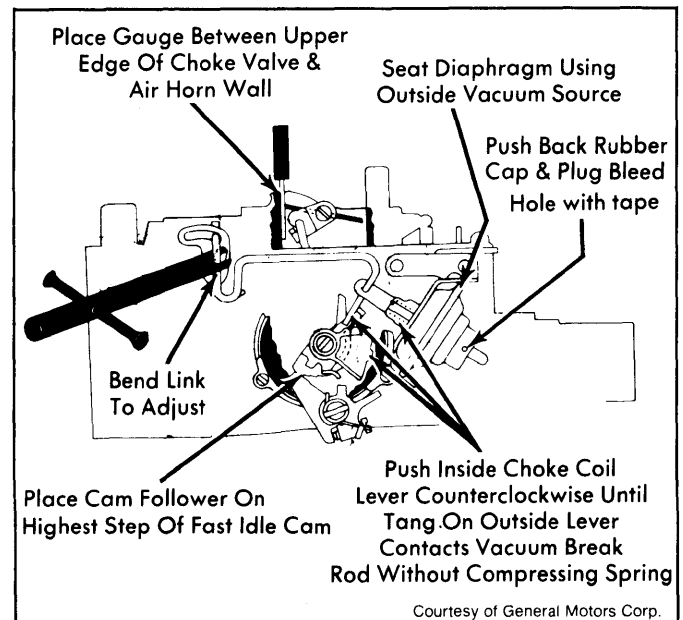

Fig. 12: Adjusting 2MC Vacuum Break (Lean Setting)

# 1975-79 FUEL SYSTEMS

## 2MC, E2ME, M2MC, M2MC-200 & M2ME 2-Barrel (Cont.)

**Lean Setting Adjustment** – 1) Place cam follower on highest step of fast idle cam. Push back rubber cap on diaphragm and cover bleeder (if equipped).

**NOTE:** On models equipped with air bleed, remove rubber cover from filter and plug vacuum tube with a piece of tape. If bleed hole is in end of diaphragm, plug hole in end of diaphragm with a piece of tape. Remove tape after completing adjustment.

2) Seat diaphragm using outside vacuum source. Remove choke cover and push inside choke coil lever counterclockwise until tang on outside lever contacts vacuum break rod. Ensure bucking spring is NOT compressed.

3) Insert specified gauge between upper edge of choke plate and air horn wall. If necessary, bend link rod to adjust. See Fig. 12.

### VACUUM DIAPHRAGMS (M2MC-200 & M2MC W/O ANGLE GAUGE)

**Rear Vacuum Break** – 1) Place cam follower on highest step of fast idle cam. Seat diaphragm using outside vacuum source. Remove choke cover and push inside choke coil lever counterclockwise until tang on outside lever contacts vacuum break rod.

**NOTE:** On models equipped with air bleed, remove rubber cover from filter and plug vacuum tube with a piece of tape. If bleed hole is in end of diaphragm, plug hole in end of diaphragm with a piece of tape. Remove tape after completing adjustment.

2) Insert specified gauge between upper edge of choke plate and air horn wall. If necessary, bend control link rod to adjust. See Fig. 13.

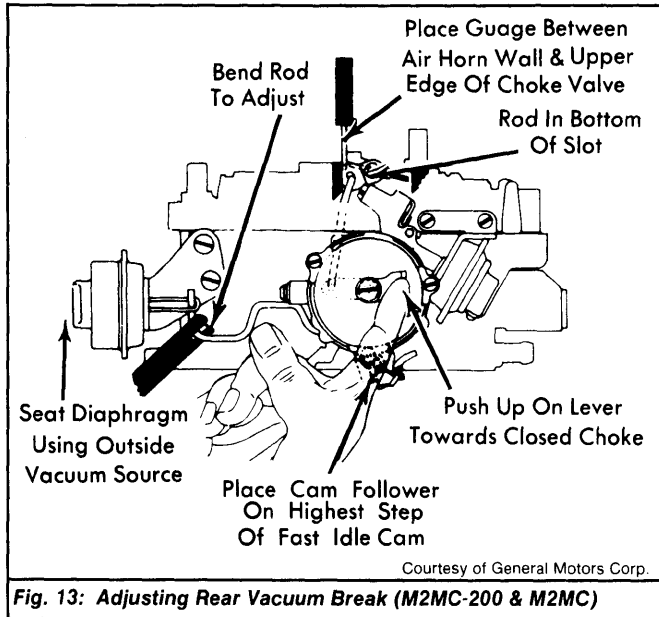

**Fig. 13: Adjusting Rear Vacuum Break (M2MC-200 & M2MC)**

**Front Vacuum Break** – 1) Place cam follower on highest step of fast idle cam. Push back rubber cap on diaphragm and cover bleeder (if equipped).

**NOTE:** On models equipped with air bleed, remove rubber cover from filter and plug vacuum tube with a piece of tape. If bleed hole is in end of diaphragm, plug hole in end of diaphragm with a piece of tape. Remove tape after completing adjustment.

2) Seat diaphragm using outside vacuum source. Remove choke cover and push inside choke coil lever counterclockwise until tang on vacuum break lever lightly contacts tang on vacuum break plunger.

3) Insert specified gauge between upper edge of choke plate and air horn wall. If necessary, turn screw to adjust. See Fig. 14.

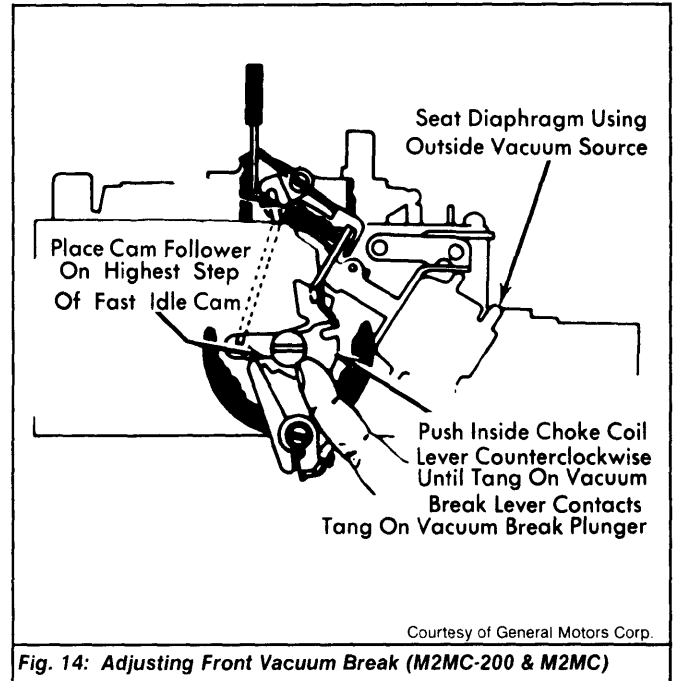

**Fig. 14: Adjusting Front Vacuum Break (M2MC-200 & M2MC)**

### VACUUM DIAPHRAGMS (E2ME, M2MC & M2ME ONLY)

**NOTE:** Choke coil lever and choke rod (fast idle cam) adjustments must be correct before performing this adjustment. Adjustment is performed with choke valve angle gauge. See procedure at beginning of ADJUSTMENTS. Do not remove rivets and choke cover to perform this adjustment.

**Primary (Front) Vacuum Break** – 1) Attach rubber band to Green tang of intermediate choke shaft. Open throttle to allow choke valve to close. Set up angle gauge.

2) Using an outside vacuum source of at least 18 in. Hg, seat primary (front) vacuum break diaphragm. Be sure leaf bucking spring is seated against lever, if equipped. See Fig. 15.

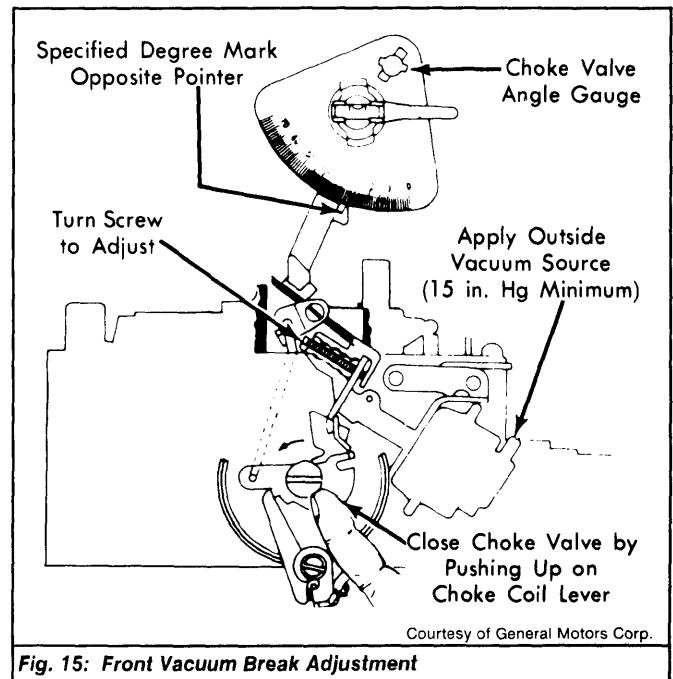

**Fig. 15: Front Vacuum Break Adjustment**

# 1975-79 FUEL SYSTEMS

## 2MC, E2ME, M2MC, M2MC-200 & M2ME 2-Barrel (Cont.)

**NOTE:** On models equipped with air bleed, remove rubber cover from filter and plug vacuum tube with a piece of tape. If bleed hole is in end of diaphragm, plug hole in end of diaphragm with a piece of tape. Remove tape after completing adjustment.

- 3) Bubble on choke valve angle gauge should be centered with specified degree mark opposite pointer.
- 4) To adjust, turn vacuum break adjustment screw. Adjustment is correct when bubble of choke valve angle gauge is centered on specified degree mark.

### SECONDARY (REAR) VACUUM BREAK

**NOTE:** Choke coil lever and choke rod (fast idle cam) adjustments must be correct before performing this adjustment. Adjustment is performed with choke valve angle gauge. See procedure at beginning of ADJUSTMENTS. Do not remove rivets and choke cover to perform this adjustment.

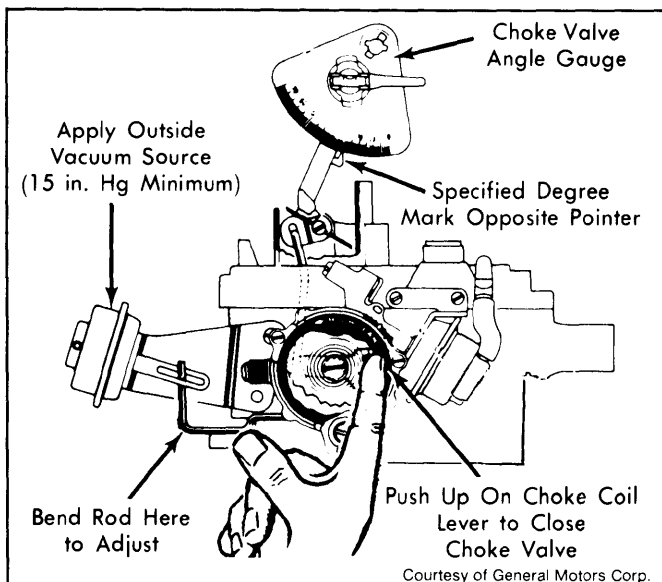

**Fig. 16: Secondary (Rear) Vacuum Break Adjustment**

- 1) Attach rubber band to Green tang of intermediate choke shaft. Open throttle to allow choke valve to close. Set up angle gauge.
- 2) Using an outside vacuum source of at least 18 in. Hg, seat secondary (rear) vacuum break diaphragm. Be sure leaf bucking spring is compressed, if equipped. See Fig. 16.

**NOTE:** On models equipped with air bleed, remove rubber cover from filter and plug vacuum tube with a piece of tape. If bleed hole is in end of diaphragm, plug hole in end of diaphragm with tape. On delay models with air bleed, plug end cover with an accelerator pump plunger cup. Remove tape or cup after completion of adjustment.

- 3) Close choke by pushing up on choke coil lever or vacuum break lever tang. Hold choke closed with a rubber band.
- 4) Bubble on choke valve angle gauge should be centered with specified degree mark opposite pointer.
- 5) To adjust, support rod at point and bend vacuum break rod with vacuum still applied. Adjustment is correct when bubble of choke valve angle gauge is centered.

### AUTOMATIC CHOKE

Loosen choke coil cover screws or remove rivets. Position fast idle cam follower on high step of fast idle cam. Retate cover until specified marks are lined up.

### CHOKE UNLOADER

**NOTE:** Choke coil lever and choke rod (fast idle cam) adjustments must be correct before performing this adjustment. Adjustment is performed with choke valve angle gauge. See procedure at beginning of Adjustments. Do not remove rivets and choke cover to perform this adjustment.

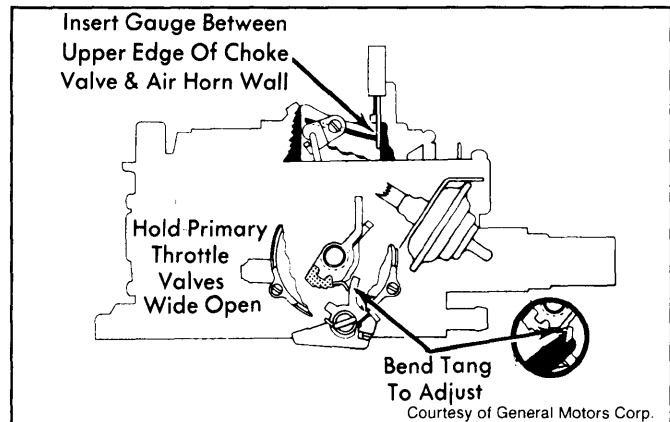

**Fig. 17: Adjusting 1975-77 Choke Unloader**

- 1) Attach rubber band to Green tang of intermediate choke shaft. Open throttle to allow choke valve to close. Set up angle gauge, if available. See Fig. 18.
- 2) Hold throttle lever in wide open position. Insert specified gauge between upper edge of choke valve and air horn wall or bubble on choke valve angle gauge should be centered with specified degree mark opposite pointer.
- 3) To adjust, bend choke unloader tang on fast idle lever. See Fig. 17. If angle gauge is used, bend tang until bubble of choke valve angle gauge is centered. See Fig. 18. Remove gauge.

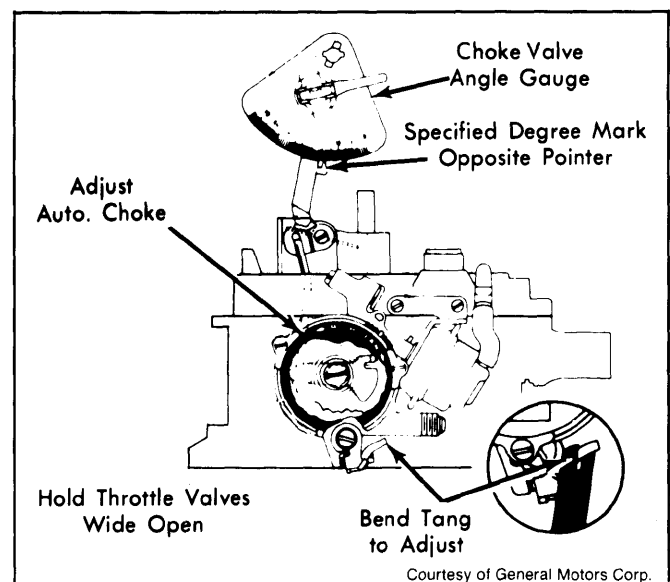

**Fig. 18: Adjusting 1978-79 Choke Unloader**

# 1975-79 FUEL SYSTEMS

## 2MC, E2ME, M2MC, M2MC-200 & M2ME 2-Barrel (Cont.)

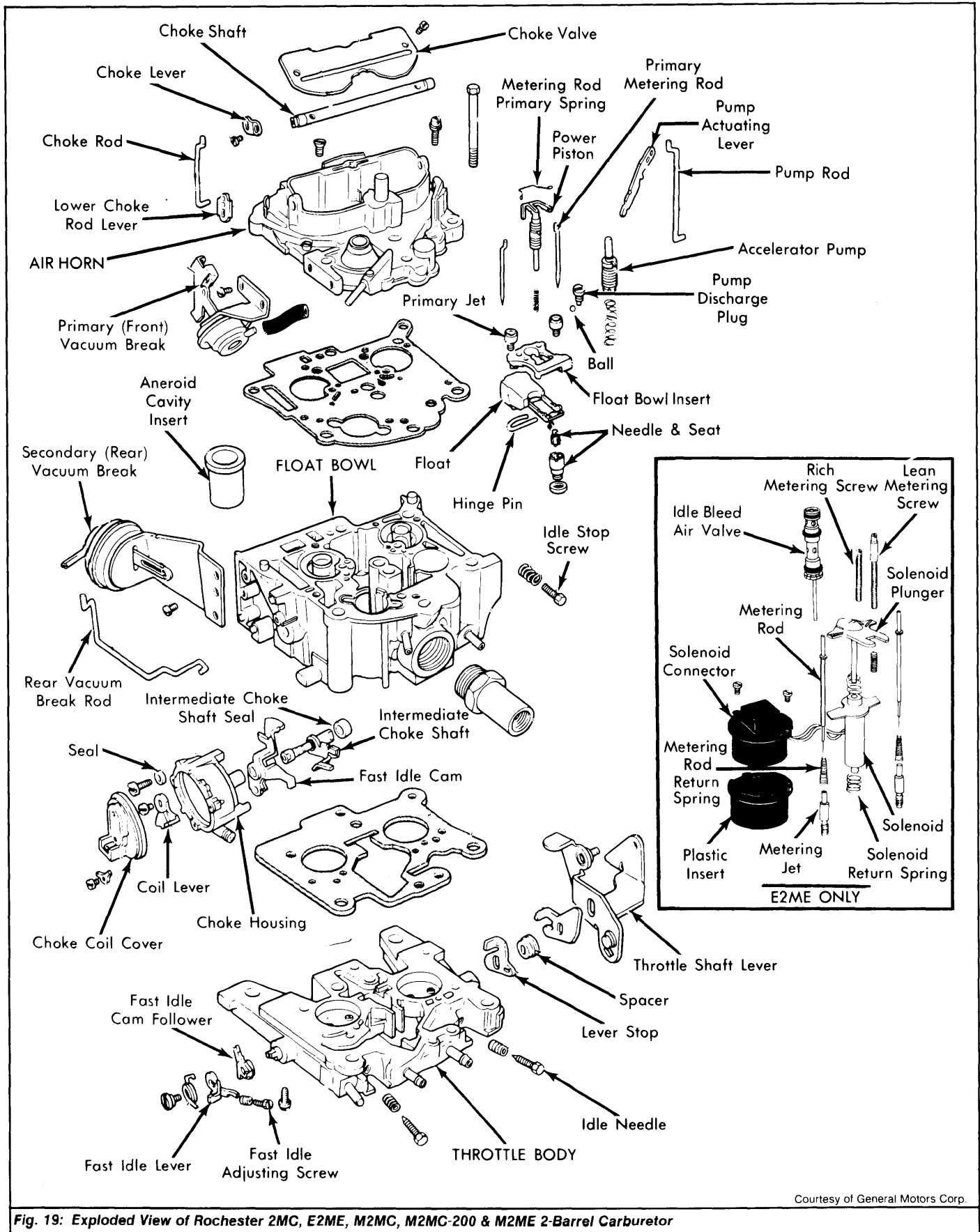

Courtesy of General Motors Corp.

Fig. 19: Exploded View of Rochester 2MC, E2ME, M2MC, M2MC-200 & M2ME 2-Barrel Carburetor

# 1975-79 FUEL SYSTEMS

## 2MC, E2ME, M2MC, M2MC-200 & M2ME 2-Barrel (Cont.)

1975 CARBURETOR ADJUSTMENT SPECIFICATIONS									
Rochester Carb. No.	Hot Idle Speed (Engine RPM) †		Float Level Setting	Pump Rod Location	Pump Rod Setting	Choke Coil Lever	Choke Rod (Fast Idle)	Vacuum Break	Unloader
	Man. Trans.	Auto. Trans.							
7045156	②	②	① 5/32"	Inner	5/32"	.120"	.130"	.150"	.300"
7045298	②	②	① 5/32"	Inner	5/32"	.120"	.130"	.150"	.300"
7045354	②	②	3/16"	Outside	3/16"	.120"	.130"	.150"	.300"
7045356	②	②	① 5/32"	Inner	5/32"	.120"	.130"	.150"	.300"
7045358	②	②	3/16"	Outside	3/16"	.120"	.130"	.150"	.300"
7045598	②	②	① 5/32"	Inner	3/16"	.120"	.130"	.150"	.300"

① — On Oldsmobile 3/16".

② — See Emission Control Tune-Up Decal in engine compartment.

1976 CARBURETOR ADJUSTMENT SPECIFICATIONS									
Rochester Carb. No.	Idle Speed (Engine RPM)	Float Level Setting	Pump Rod Location	Pump Rod Setting	Choke Coil Lever	Choke Rod (Fast Idle)	Vacuum Break (Rich)	Vacuum Break (Lean)	Unloader
17056156	①	1/8"	Inner	5/32"	.120"	.105"	.110"	.175"	.210"
17056157	①	1/8"	Outer	3/16"	.120"	.105"	.110"	.175"	.210"
17056158	①	1/8"	Inner	5/32"	.120"	.105"	.110"	.175"	.210"
17056454	①	1/8"	Outer	3/16"	.120"	.105"	.110"	.210"	.210"
17056455	①	1/8"	Inner	5/32"	.120"	.120"	.130"	.210"	.210"
17056456	①	1/8"	Outer	3/16"	.120"	.105"	.110"	.210"	.210"
17056457	①	1/8"	Outer	3/16"	.120"	.105"	.110"	.245"	.210"
17056458	①	1/8"	Outer	3/16"	.120"	.105"	.110"	.210"	.210"
17056459	①	1/8"	Outer	3/16"	.120"	.105"	.110"	.210"	.210"

① — See Emission Control Tune-Up Decal.

1977 CARBURETOR ADJUSTMENT SPECIFICATIONS										
Rochester Carb. No.	Idle Speed (Engine RPM)		Float Level Setting	Pump Rod Setting	Choke Rod ① (Fast Idle)	Vacuum Break (Rich)	Vacuum Break (Lean)	Vacuum Break (Front)	Vacuum Break (Rear)	Choke Unloader
	Hot	Fast								
17057150	650②	900③	1/8"	1 1/32"⑤	.085"	.090"	.160"	.....	.....	.190"
17057151	650④	900③	1/8"	1 1/32"⑤	.085"	.090"	.160"	.....	.....	.190"
17057156	650②	900③	1/8"	1 1/32"⑤	.085"	.090"	.160"	.....	.....	.190"
17057157	750⑥	900	1/8"	3/8"⑤	.090"	.100"	.190"	.....	.....	.190"
17057158	550④	900	1/8"	1 1/32"⑤	.085"	.090"	.160"	.....	.....	.190"
17057172	650②	1750③	1 1/32"	3/8"⑤	.075"	.....	.....	.135"	.225"	.240"
17057173	850⑦	1750③	1 1/32"	3/8"⑤	.075"	.....	.....	.135"	.225"	.240"

① — Choke coil lever — All — .120".

② — A/T in DRIVE, A/C on.

③ — Trans. in NEUTRAL.

④ — A/T in DRIVE, no A/C.

⑤ — Outer pump hole (all).

⑥ — Adjust dashpot; depress plunger; .040" gap.

⑦ — Trans. in NEUTRAL, A/C on.

# 1975-79 FUEL SYSTEMS

## 2MC, E2ME, M2MC, M2MC-200 & M2ME 2-Barrel (Cont.)

1978 CARBURETOR ADJUSTMENT SPECIFICATIONS										
Rochester Carb. No.	Idle Speed (Engine RPM)		Float Level Setting	Acc. Pump Rod	Choke Coil Lever	Choke Rod (Cam)	Front Vacuum Break	Rear Vacuum Break	Choke Unloader	Auto. Choke
	Hot	Fast								
<b>BUICK</b>										
M2MC										
17058160	①	①	11/32"	1/4"②	.120"	23.5°	26°	36°	35°	2 NL
M2ME										
17058192	①	①	1/4"	9/32"③	.120"	14.5°	21°	19°	50°	1 NR
17058496	①	①	1/4"	3/8"②	.120"	15.0°	24°	34°	38°	1 NR
<b>CHEVROLET</b>										
M2ME										
17058130	①	①	1/4"	9/32"③	.120"	46°	24°	.....	46°	2 NL
17058131	①	①	1/4"	9/32"③	.120"	46°	24°	.....	46°	2 NL
17058132	①	①	1/4"	9/32"③	.120"	46°	24°	.....	46°	2 NL
17058133	①	①	1/4"	9/32"③	.120"	46°	24°	.....	46°	2 NL
17058182	①	①	1/4"	9/32"③	.120"	46°	24°	.....	46°	2 NL
<b>OLDSMOBILE</b>										
M2MC										
17058150	①	①	3/8"	1/4"③	.120"	14°④	35°⑤	25°⑧	35°⑨	2 NR
17058151	①	①	3/8"	11/32"②	.120"	14°④	38°⑤	25°⑧	35°⑨	2 NR
17058152	①	①	3/8"	1/4"③	.120"	14°④	35°⑤	25°⑧	35°⑨	2 NR
17058154	①	①	3/8"	11/32"②	.120"	14°④	27°⑦	40°⑩	35°⑨	2 NR
17058155	①	①	3/8"	11/32"②	.120"	14°④	27°⑦	40°⑩	35°⑨	2 NR
17058156	①	①	3/8"	11/32"②	.120"	14°④	38°⑥	25°⑧	35°⑨	2 NR
17058158	①	①	3/8"	11/32"②	.120"	14°④	38°⑥	25°⑧	35°⑨	2 NR
17058450	①	①	3/8"	11/32"②	.120"	14°④	27°⑦	45°⑩	35°⑨	2 NR
<b>PONTIAC</b>										
M2MC										
17058160	①	①	11/32"	1/4"③	.120"	22.5°⑪	25°⑫	32°⑬	33°⑭	2 NR

- ① — See Emission Control Tune-Up Decal.  
 ② — Outer hole of pump lever.  
 ③ — Inner hole of pump lever.  
 ④ — Plug gauge measurement = .065".  
 ⑤ — Plug gauge measurement = .203".  
 ⑥ — Plug gauge measurement = .229".  
 ⑦ — Plug gauge measurement = .146".

- ⑧ — Plug gauge measurement = .133".  
 ⑨ — Plug gauge measurement = .245".  
 ⑩ — Plug gauge measurement = .289".  
 ⑪ — Plug gauge measurement = .126".  
 ⑫ — Plug gauge measurement = .142".  
 ⑬ — Plug gauge measurement = .195".

# 1975-79 FUEL SYSTEMS

## 2MC, E2ME, M2MC, M2MC-200 & M2ME 2-Barrel (Cont.)

1979 CARBURETOR ADJUSTMENT SPECIFICATIONS									
Application	Float Level Setting	Accelerator Pump		Choke Coil Lever Setting	Choke Rod Setting <sup>⓪</sup>	Vacuum Break		Auto. Choke Setting	Choke Unloader Setting <sup>⓪</sup>
		Lever Setting	Hole Setting			Primary Setting <sup>⓪</sup>	Secondary Setting <sup>⓪</sup>		
<b>Model E2ME</b> 17059496	5/16"	3/8"	Inner	.120"	24.5°	21°	30°	2NR	38°
<b>Model M2MC</b>									
17059134	15/32"	1/4"	Inner	.120"	38°	27°	.....	1NL	38°
17059135	15/32"	1/4"	Inner	.120"	38°	27°	.....	1NL	38°
17059136	15/32"	1/4"	Inner	.120"	38°	27°	.....	1NL	38°
17059137	15/32"	1/4"	Inner	.120"	38°	27°	.....	1NL	38°
17059138	1/4"	1/4"	Inner	.120"	38°	28°	.....	1NL	38°
17059139	1/4"	1/4"	Inner	.120"	38°	28°	.....	1NL	38°
17059140	1/4"	1/4"	Inner	.120"	38°	28°	.....	1NL	38°
17059141	1/4"	1/4"	Inner	.120"	38°	28°	.....	1NL	38°
17059150	3/8"	1/4"	Inner	.120"	14°	32°	23°	2NR	35°
17059151	3/8"	11/32"	Outer	.120"	14°	38°	25°	2NR	35°
17059152	3/8"	1/4"	Inner	.120"	14°	32°	23°	2NR	35°
17059154	3/8"	11/32"	Outer	.120"	14°	27°	40°	2NR	35°
17059160	11/32"	1/4"	Inner	.120"	20°	23°	31°	2NR	32°
17059430	9/32"	9/32"	Inner	.120"	38°	27°	.....	1NL	38°
17059432	9/32"	9/32"	Inner	.120"	38°	27°	.....	1NL	38°
17059434	15/32"	1/4"	Inner	.120"	38°	29°	.....	1NL	38°
17059436	15/32"	1/4"	Inner	.120"	38°	29°	.....	1NL	38°
17059450	3/8"	11/32"	Outer	.120"	14°	27°	.....	2NR	35°
<b>Model M2ME</b>									
17059130	1/4"	9/32"	Inner	.120"	38°	27°	.....	Index	38°
17059131	1/4"	3/8"	Inner	.120"	38°	27°	.....	1NL	38°
17059132	1/4"	9/32"	Inner	.120"	38°	27°	.....	Index	38°
17059133	1/4"	9/32"	Inner	.120"	38°	27°	.....	1NL	38°
17059170	1/4"	9/32"	Inner	.120"	38°	27°	.....	Index	38°
17059171	1/4"	9/32"	Inner	.120"	38°	27°	.....	Index	38°
17059180	11/32"	1/4"	Inner	.120"	24.5°	19°	17°	2NR	38°
17059184	11/32"	1/4"	Inner	.120"	24.5°	19°	17°	2NR	35°
17059190	11/32"	9/32"	Inner	.120"	24.5°	19°	17°	2NR	38°
17059191	11/32"	9/32"	Inner	.120"	24.5°	19°	17°	2NR	38°
17059193	13/32"	1/4"	Inner	.120"	24.5°	19°	17°	2NR	35°
17059194	11/32"	1/4"	Inner	.120"	24.5°	19°	17°	2NR	35°
17059196	11/32"	1/4"	Inner	.120"	24.5°	23°	21°	1NR	42°
17059491	11/32"	9/32"	Inner	.120"	24.5°	23°	21°	1NR	42°
17059492	11/32"	9/32"	Inner	.120"	24.5°	23°	21°	1NR	42°
17059498	11/32"	9/32"	Inner	.120"	24.5°	23°	21°	2NR	42°

⓪ - 14° = .071"; 17° = .090"; 19° = .103"; 20° = .110"; 21° = .117"; 23° = .129"; 24.5° = .139"; 25° = .142"; 27° = .157"; 28° = .164"; 29° = .171"; 31° = .187"; 32° = .195"; 35° = .220"; 38° = .243"; 40° = .260"; 42° = .227".