

1975-79 FUEL SYSTEMS

Rochester 1MV Single Barrel

1975-76 Chevrolet Camaro, Chevelle,
Malibu, Monza, Nova, Vega
Buick Skylark
Oldsmobile Cutlass, Omega
Pontiac Astre, Firebird, LeMans,
Sunbird, Ventura

CARBURETOR APPLICATION

GENERAL MOTORS 1MV CARB. APPLICATIONS

Application	Man. Trans.	Rochester Carb. No.	
		Auto. Trans.	
1975			
140" 4-Cyl.			
Federal	7045025, 029	7045024, 028	
250" 6-Cyl.			
Federal	7045013	7045012	
Calif.		7045014	
1976			
140" 4-Cyl.			
Federal			
Without A/C	7056023	7056022	
With A/C	7056027	7056026	
250" 6-Cyl.			
Federal	¹ 7056013, 015	² 7056012, 14, 18	
Calif.		7056012, 014	

¹ - No. 013 is for 2.73 axle; 015 is for 3.08 axle.

² - On Chevrolet Nova with RPO Z14 (separate intake manifold), Carb. No. is 17056016.

CARBURETOR IDENTIFICATION

The carburetor model identification is stamped on a vertical portion of the float bowl, adjacent to the fuel inlet nut. If replacing float bowl, follow manufacturer's instructions contained in service package so that the identification number can be transferred to the new float bowl.

DESCRIPTION

The Rochester model 1MV carburetor is a single bore downdraft type carburetor using a triple venturi in conjunction with a plain tube nozzle. This model carburetor incorporates automatic choke with manifold mounted coil and a connecting rod to throttle choke plate system. The choke vacuum diaphragm is mounted externally to carburetor air horn and is connected to thermostatic coil lever through a connector link. An electrically actuated idle stop solenoid and dual throttle return springs are used on all models.

ADJUSTMENTS

NOTE: For all adjustments not covered in this article, see appropriate article in TUNE-UP PROCEDURES section.

CHOKE ROD (FAST IDLE CAM)

1) Ensure fast idle speed is correctly set. Place fast idle cam follower on SECOND step of fast idle cam, against HIGHEST step. See Fig. 1.

2) Apply light closing pressure to choke valve. Ensure choke rod is in lower end slot of choke lever. Measure specified clearance between lower edge of choke valve and air horn wall. Measurement can be made with a specified drill or pin gauge. To adjust, bend choke rod.

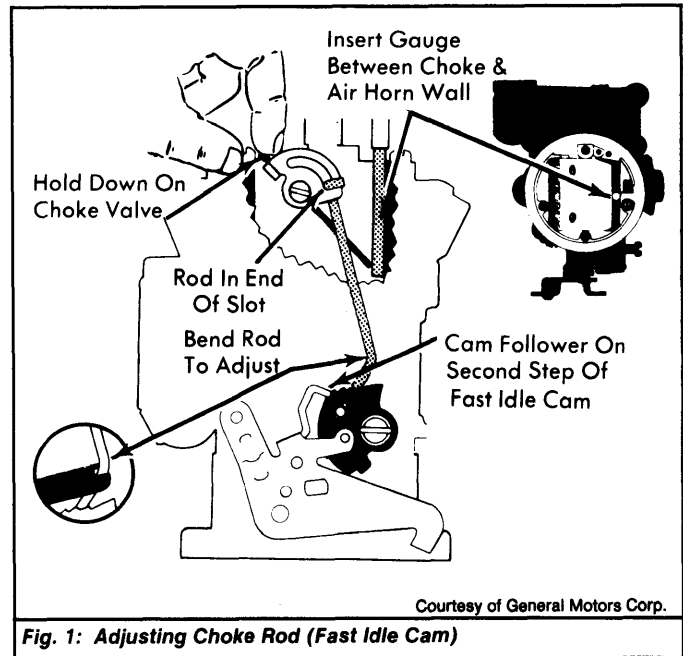

Fig. 1: Adjusting Choke Rod (Fast Idle Cam)

PRIMARY VACUUM BREAK

1) Use outside vacuum source and apply enough vacuum to seat diaphragm. See Fig. 2 or 3. Diaphragm plunger should be IN and seated.

2) Close choke valve and insert specified gauge between lower edge of choke valve and air horn wall. Bend rod until snug in end of diaphragm plunger slot.

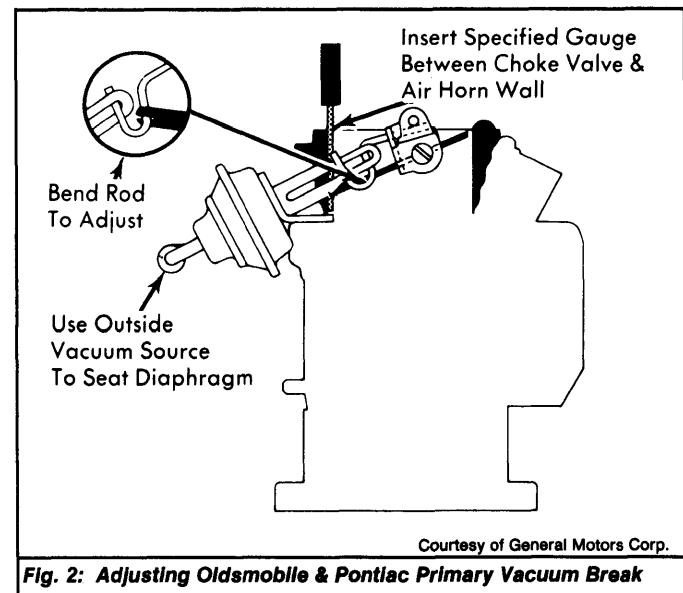

Fig. 2: Adjusting Oldsmobile & Pontiac Primary Vacuum Break

1975-79 FUEL SYSTEMS

Rochester 1MV Single Barrel (Cont.)

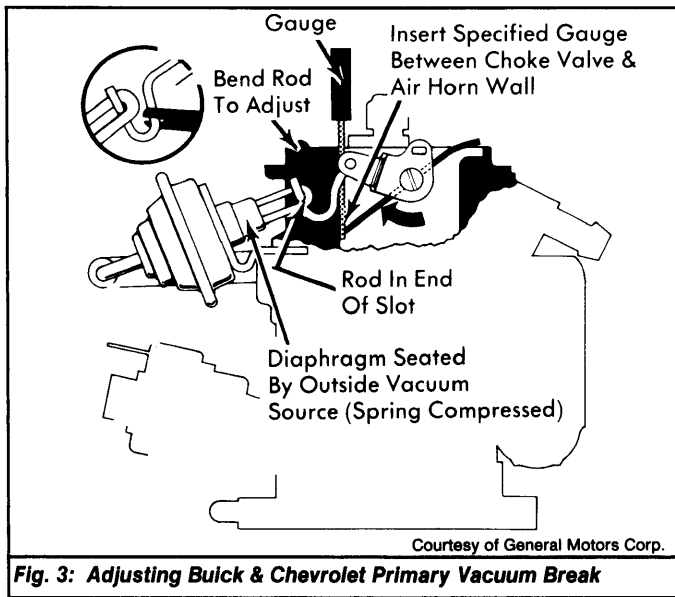

Fig. 3: Adjusting Buick & Chevrolet Primary Vacuum Break

AUXILIARY VACUUM BREAK

All Except Pontiac Astre - 1) Place fast idle screw or cam follower on highest step of fast idle cam. Use outside vacuum source and apply enough vacuum to seat diaphragm. See Fig. 4. Diaphragm plunger should be IN and seated.

2) Close choke valve and insert specified gauge between lower edge of choke valve and air horn wall. Bend vacuum break link at bend until snug in end of diaphragm plunger slot.

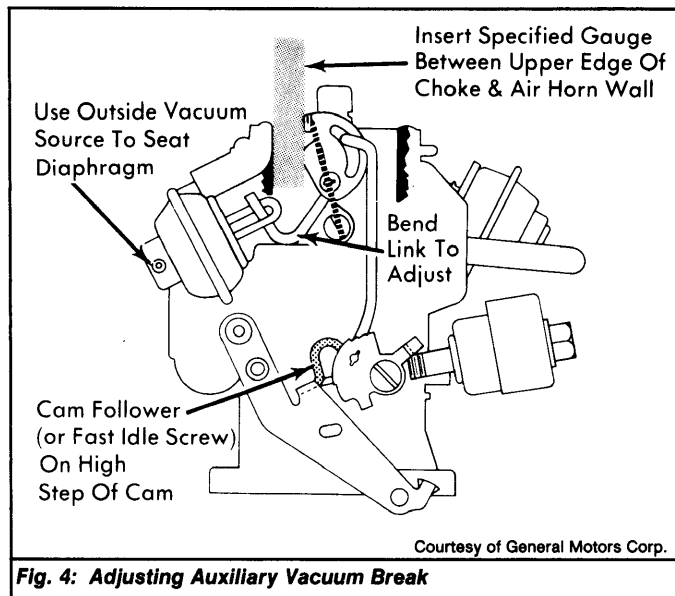

Fig. 4: Adjusting Auxiliary Vacuum Break

CHOKE UNLOADER

1) Open throttle valve wide open. Apply light closing pressure to choke valve. Measure specified clearance between lower edge of choke valve and air horn wall. See Fig. 5.

2) Measurement can be made with a specified drill or pin gauge. To adjust, bend choke unloader tang.

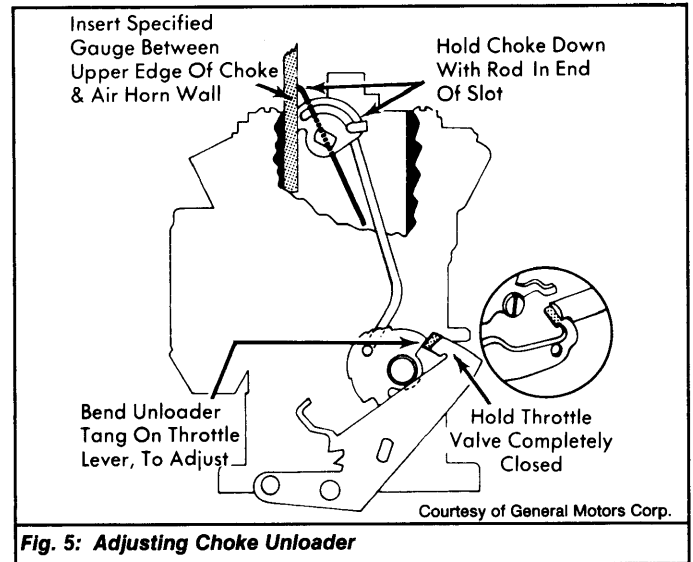

Fig. 5: Adjusting Choke Unloader

CHOKE COIL ROD

Astre, Monza & Vega - 1) Hold choke valve closed. See Fig. 6. Disconnect choke coil rod. Push rod down until stop is felt.

2) If adjustment is correct, top of rod or swivel pin should be even with bottom of hole in choke control lever. If necessary, bend choke control rod to adjust.

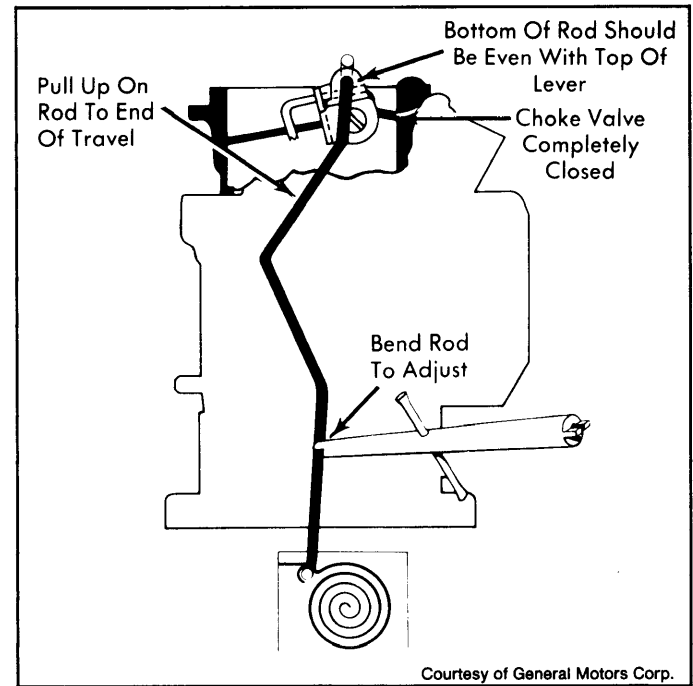

Fig. 6: Adjusting Astre, Monza & Vega Choke Coil Rod

All Others - 1) Disconnect top end of choke control rod. Hold choke valve closed. See Fig. 7. Push rod down until stop is felt.

2) If adjustment is correct, top edge of rod or swivel pin should be even with top of choke control lever. If necessary, bend choke control rod to adjust.

1975-79 FUEL SYSTEMS

Rochester 1MV Single Barrel (Cont.)

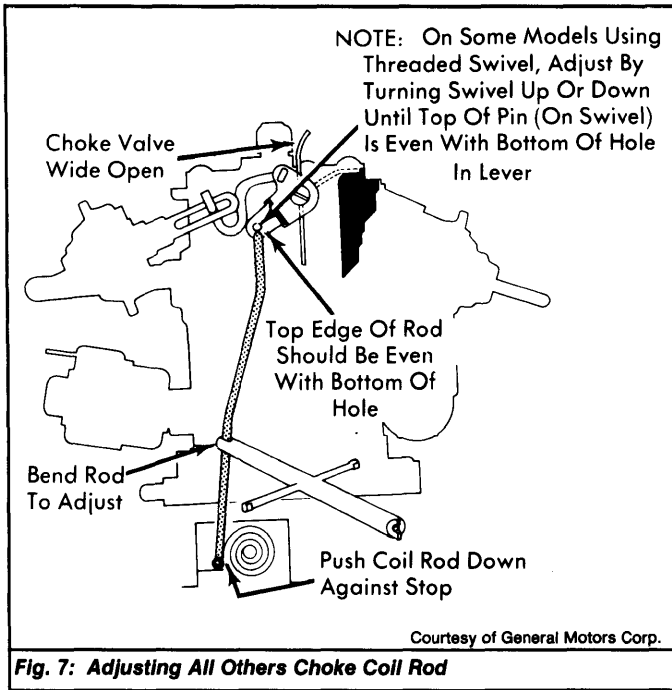

Fig. 7: Adjusting All Others Choke Coil Rod

FLOAT LEVEL

- 1) Remove air horn. Hold float pin firmly in place. Push down on end of float arm against top of float needle. See Fig. 8.
- 2) With gasket removed, use a depth or "T" scale to measure distance from top of casting to index point at toe of float.
- 3) If adjustment is needed, gently bend float arm up or down. Do not force needle against needle seat.

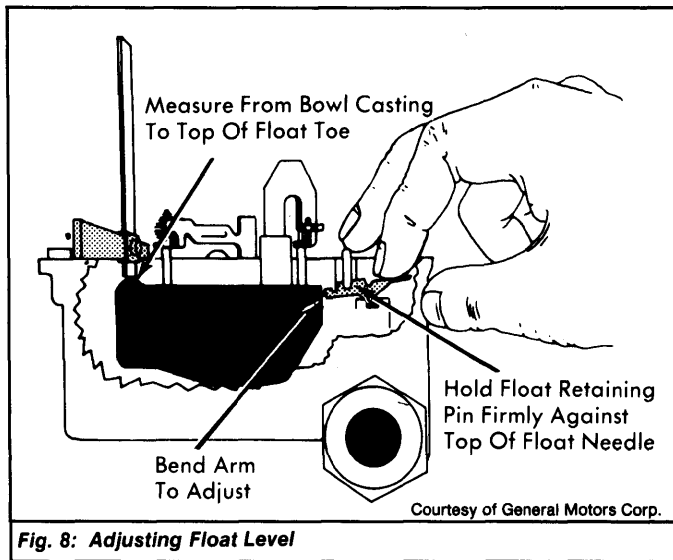

Fig. 8: Adjusting Float Level

METERING ROD ADJUSTMENT

- All Models Except Astre & Vega** - 1) Remove air horn and gasket. Hold throttle valve wide open. Push down on metering rod against spring tension. See Fig. 9. Slide metering rod out of slot in holder and remove from main metering jet.
- 2) Back out idle stop solenoid. Hold throttle valve in fully closed position. Press down on power piston. Measure specified clearance between rod holder and carburetor surface. Measurement can be made using a drill or pin gauge.
- 3) If adjustment is needed, gently bend holder arm up or down. Recheck clearance. Reassemble carburetor. Install new air horn-to-body gasket. Check for leaks.

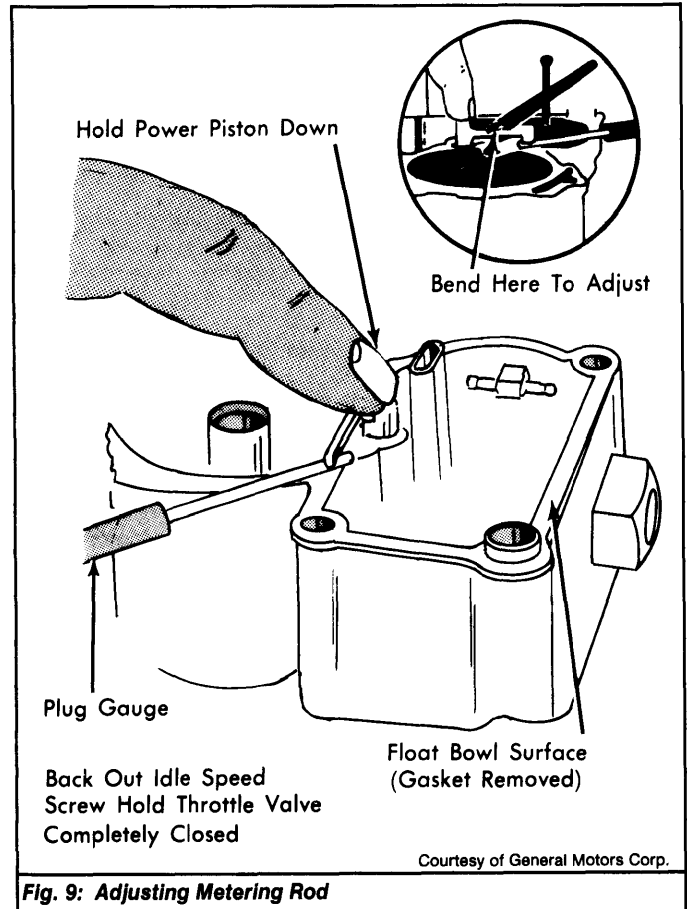

Fig. 9: Adjusting Metering Rod

OVERHAUL

CARBURETOR

Refer to Fig. 10. for disassembly and reassembly. Ensure all carburetor passages air clean. Use new gaskets on reassembly.

1975-79 FUEL SYSTEMS

Rochester 1MV Single Barrel (Cont.)

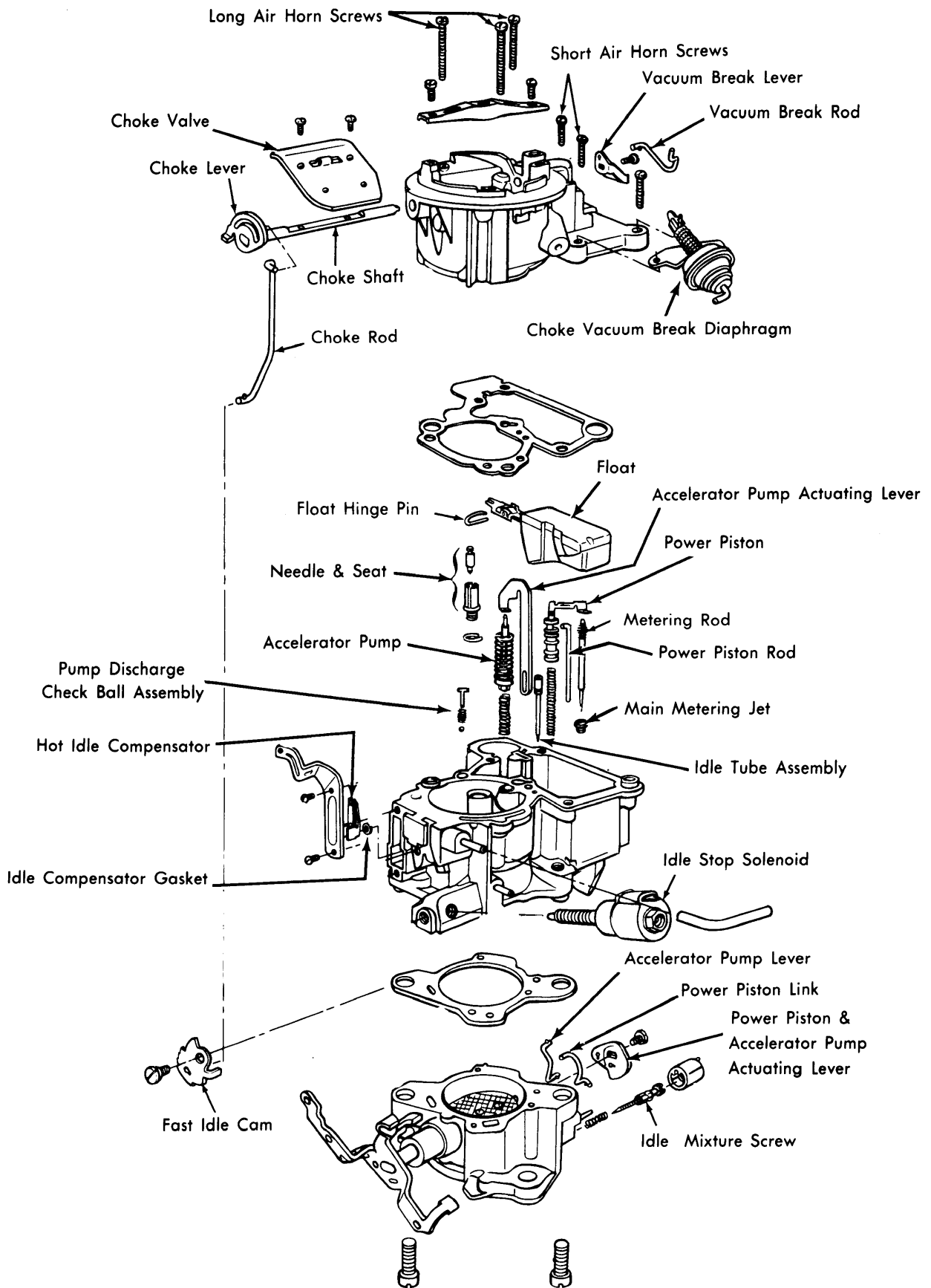

Fig. 10: Exploded View of 1MV Carburetor

Courtesy of General Motors Corp.

1975-79 FUEL SYSTEMS

Rochester 1MV Single Barrel (Cont.)

1975 CARBURETOR ADJUSTMENT SPECIFICATIONS									
Rochester Car. No. ①	Idle Speed (Engine RPM)		Float Level Setting	Metering Rod Setting	Fast Idle Choke Rod	Aux. Vacuum Break	Vacuum Break Setting	Unloader Setting	Auto. Choke Setting
	Hot	Fast							
Buick									
5012	③	③	$1\frac{1}{32}$ "	.080"	.160"	.215"	.200"	.275"	②
5013	③	③	$1\frac{1}{32}$ "	.080"	.275"	.312"	.350"	.275"	②
5014	③	③	$1\frac{1}{32}$ "	.080"	.230"	.312"	.275"	.275"	②
Chevrolet (Exc. Vega)									
5012	③	③	$1\frac{1}{32}$ "	.070"	.160"	.215"	.200"	.215"	②
5013	③	③	$1\frac{1}{32}$ "	.070"	.275"	.312"	.350"	.275"	②
5014	③	③	$1\frac{1}{32}$ "	.070"	.230"	.312"	.275"	.275"	②
Chevrolet Vega									
5024	550/750	2200	$\frac{1}{8}$ "080"	.450"	.100"	.375"
5025	700	2000	$\frac{1}{8}$ "080"	.450"	.100"	.375"
5028	550/750	2200	$\frac{1}{8}$ "080"	.450"	.100"	.375"
5029	700	2000	$\frac{1}{8}$ "080"	.450"	.100"	.375"
Oldsmobile									
5012	425/550	③	$1\frac{1}{32}$ "	.080"	.160"	.215"	.200"	.275"	②
5013	425/850	③	$1\frac{1}{32}$ "	.080"	.275"	.312"	.350"	.275"	②
5014	425/550	③	$1\frac{1}{32}$ "	.080"	.160"	.215"	.200"	.275"	②
Pontiac (Exc. Astre)									
5012	③	③	$1\frac{1}{32}$ "	.080"	.160"	.215"	.200"	.275"	②
5013	③	③	$1\frac{1}{32}$ "	.080"	.275"	.312"	.350"	.275"	②
5014	③	③	$1\frac{1}{32}$ "	.080"	.230"	.312"	.275"	.275"	②
Pontiac Astre									
Man Trans.	700	2000	$\frac{1}{8}$ "080"130"	.375"
Auto Trans.	750	2200	$\frac{1}{8}$ "080"130"	.375"

① — Prefix number is 704

② — One Rod Diameter Lean.

③ — Refer to Emission Control Tune-Up Decal.

1975-79 FUEL SYSTEMS

Rochester 1MV Single Barrel (Cont.)

1976 CARBURETOR ADJUSTMENT SPECIFICATIONS									
Rochester Car. No. ①	Idle Speed (Engine RPM)		Float Level Setting	Metering Rod Setting	Fast Idle Choke Rod	Aux. Vacuum Break	Vacuum Break Setting	Unloader Setting	Auto. Choke Setting
	Hot ②	Fast							
Chevrolet									
6012	425/550	2100	1 1/32"	.084"	.090"	.215"	.110"	.265"	③
6013	425/850	2100	1 1/32"	.082"	.090"	.215"	.110"	.265"	③
6014	425/550	2100	1 1/32"	.080"	.090"	.215"	.110"	.265"	③
6015	425/850	2100	1 1/32"	.080"	.090"	.215"	.110"	.265"	③
6016	425/600	2200	1 1/32"	.080"	.115"	W.O.	.140"	.265"	③
6018	425/550	2100	1 1/32"	.084"	.090"	.215"	.110"	.265"	③
6022	550/750	2200	1/8"045"	.450"	.060"	.215"	③
6023	750/1200	1500	1/8"045"	.450"	.060"	.215"	③
6026	550/750	2200	1/8"045"	.450"	.060"	.215"	③
6027	750/1200	2200	1/8"045"	.450"	.060"	.215"	③
6314	425/600	1700	1 1/32"	.083"	.135"	.275"	.150"	.265"	③
Oldsmobile									
6012	425/550	④	1 1/32"	.080"	.100"	.265"	.140"	.265"	③
6013	425/850	④	1 1/32"	.080"	.140"	.320"	.165"	.265"	③
6014	425/550	④	1 1/32"	.080"	.100"	.265"	.140"	.265"	③
6015	425/850	④	1 1/32"	.080"	.140"	.320"	.165"	.265"	③
6018	425/550	④	1 1/32"	.080"	.100"	.260"	.140"	.265"	③
6314	425/550	④	1 1/32"	.080"	.135"	.320"	.165"	.265"	③
Pontiac									
6012	550	④	1 1/32"090"	.215"	.110"	.265"	③
6013	850	④	1 1/32"090"	.215"	.110"	.265"	③
6014	550	④	1 1/32"090"	.215"	.110"	.265"	③
6015	850	④	1 1/32"090"	.215"	.110"	.265"	③
6018	⑤550	④	1 1/32"090"	.215"	.110"	.265"	③
6022	750	④	1/8"045"	.450"	.060"	.215"	③
6023	700	④	1/8"045"	.450"	.060"	.215"	③
6026	750	④	1/8"045"	.450"	.060"	.215"	③
6027	700	④	1/8"045"	.450"	.055"	.215"	③
6312	600	④	1 1/32"135"	.275"	.150"	.265"	③
6314	600	④	1 1/32"135"	.275"	.150"	.265"	③

- ① — Prefix number is 1705.
- ② — First figure shown is solenoid de-energized.
- ③ — Refer to "Choke Coil Rod Adjustment".
- ④ — Refer to Emission Control Tune-Up Decal.
- ⑤ — LeMans with Air Cond. is 575.