

# 1975-79 TUNE-UP PROCEDURES

## Pontiac 4-Cylinder

1-109

### ENGINE IDENTIFICATION

#### VEHICLE IDENTIFICATION NUMBER

Fifth character of Vehicle Identification Number (VIN), located on plate attached to top left side of instrument panel, is the engine code.

#### VIN CODE

Application	Code
140"	
1-Bbl. ....	A
2-Bbl. ....	B
151"	
1977 .....	V
1978-79	
Federal .....	V
California .....	1

#### ENGINE IDENTIFICATION CODE

Number is located on a pad at right side of cylinder block above starter on 140" and 151" engines, by distributor shaft hole on VIN 1 engines, and on a pad at left front of block on VIN V engines.

### TUNE-UP NOTES

**NOTE:** In order to comply with emission standards, specifications shown on Emission Control Tune-Up Decal must be used in all instances.

**NOTE:** The EPA High Altitude emission standards apply to vehicles sold in certain areas outside California which have an elevation above 4000 feet.

**CAUTION:** Before making a compression test or cranking engine with a remote starting switch, disconnect ignition switch connector (Pink wire) from High Energy Ignition (HEI) system distributor.

**CAUTION:** Do not remove spark plug wires with engine running. HEI secondary voltage is higher than standard ignition systems any may inflict harmful electrical shock.

**CAUTION:** Damage to HEI electronic module and/or ignition coil may result if "TACH" terminal, in distributor cap connector or on ignition coil, is directly grounded.

### ENGINE COMPRESSION

Remove air cleaner. Place throttle and choke in wide open position. Check compression through at least 4 compression strokes.

**NOTE:** If using a remote starter switch, disconnect the ignition switch connector (Pink wire) from HEI distributor.

#### ENGINE COMPRESSION

Application	Specification
Compression Ratio	
140" .....	8.0-1
151"	
VIN 1 (LS6) .....	8.3-1
VIN V (LX8) .....	8.2-1
Recommended Fuel .....	Unleaded (87 AKI Minimum)
Compression Pressure (At 160 RPM Minimum) .....	140 psi
Max. Variation Between Cylinders .....	20 psi

### VALVE CLEARANCE

#### VALVE CLEARANCE

Application	Specification
140" Only	
Intake (Cold) .....	<sup>1</sup> .014-.017"
Exhaust (Cold) .....	<sup>1</sup> .029-.032"
All Others	
Hydraulic Lifters .....	Zero Lash

<sup>1</sup> - One turn on adjustment screw equals .003" lash change. Adjustment screw must be turned one full turn for each .003" change in lash.

### VALVE ARRANGEMENT

140"

All Engines - I-E-I-E-I-E-I-E

151"

VIN 1 (LS6) &

VIN V (Except LX8) - E-I-I-E-E-I-I-E

VIN V (LX8) - I-E-I-E-E-I-E-I

### SPARK PLUGS

#### SPARK PLUG INSTALLATION

Application	Specification
Gap	
140"	
1975 .....	.060"
1976 .....	.030"
1977 .....	.035"
151" .....	.060"
Torque .....	15 ft. lbs.

#### SPARK PLUG TYPE

Application	AC NO.
140"	
1975 .....	R43TSX
1976-77 .....	R43TS
151"	
1977 .....	R44TSX
1978-79 .....	R43TSX

### HIGH TENSION WIRE RESISTANCE

Carefully remove ends of wire from spark plug and distributor. Using an ohmmeter, check resistance while gently twisting wire. If resistance is not to specification, or fluctuates from infinity to any value, replace wire.

#### RESISTANCE (OHMS) PER WIRE

Application	Resistance (Ohms)
1975-76 .....	3000-7000
1977-79 .....	50,000 Max.

# 1975-79 TUNE-UP PROCEDURES Pontiac 4-Cylinder (Cont.)

## DISTRIBUTOR

All models are equipped with High Energy Ignition systems and no adjustments are required.

**NOTE:** If engine does not start, check Pink wire at HEI connector.

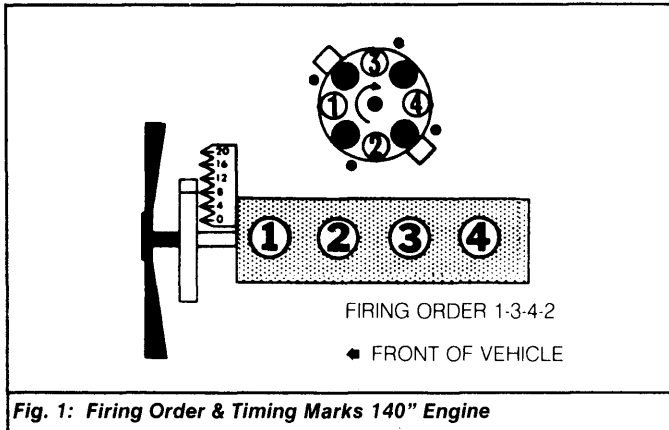

**Fig. 1: Firing Order & Timing Marks 140" Engine**

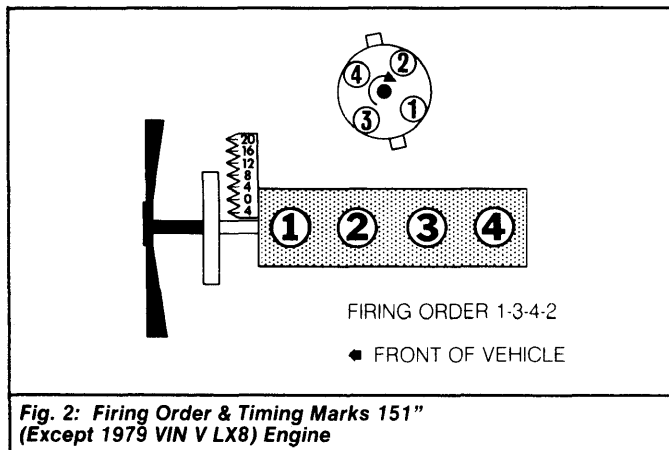

**Fig. 2: Firing Order & Timing Marks 151" (Except 1979 VIN V LX8) Engine**

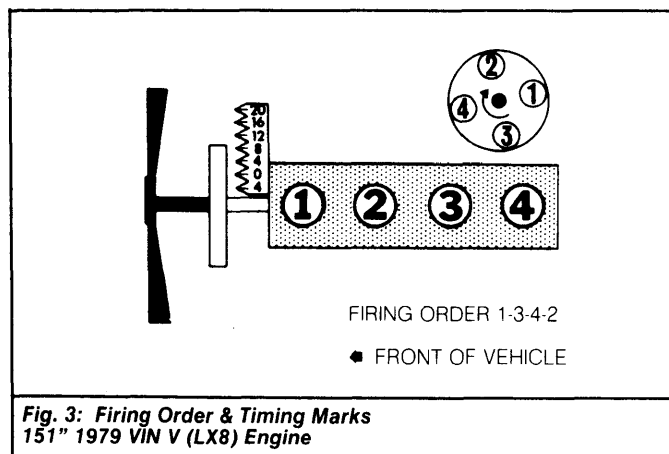

**Fig. 3: Firing Order & Timing Marks 151" 1979 VIN V (LX8) Engine**

- 2) Disconnect and plug PCV hose from vapor canister. Disconnect and plug vacuum advance hose at distributor. Place automatic transmission in Drive and manual transmission in Neutral.
- 3) Timing light connection should be made in parallel using an adapter at number No. 1 terminal on distributor cap. Check timing and adjust as necessary.

**NOTE:** For a no start condition, check connection of Pink wire at distributor cap.

## IGNITION TIMING SPECIFICATIONS <sup>1</sup>

Application	Man. Trans.	Auto. Trans.
1975		
1-Bbl. ....	8°@700	10°@550
2-Bbl. ....	10°@700	12°@600
1976 (All) .....	8°@700	10°@600
1977		
140"		
Fed. & Alt. ....	0°@700	2°@700
Calif. ....	2°@700	
151"		
Federal .....	14°@1000	14°@650
Calif. ....		12°@650
1978 (All) .....	14°@1000	<sup>3</sup> 14°@1000
1979		
Sunbird		
Federal .....	12°@900	12°@650
Calif. ....	14°@1000	14°@1000

- <sup>1</sup> - Specifications are BTDC ( $\pm 2^\circ$ ) at specified RPM.
- <sup>2</sup> - Set ATDC.
- <sup>3</sup> - Set Federal Sunbird at 12°@1000.

## HOT (SLOW) IDLE RPM

With engine at normal operating temperature, choke in full open position and air conditioning (if equipped) in "OFF" position, disconnect and plug distributor vacuum advance hose, and PCV hose at vapor canister. Place automatic transmission in Drive or manual transmission in Neutral. Proceed as follows:

**NOTE:** Ensure idle speed and ignition timing are properly set before reconnecting vacuum hoses.

**140"** - Disconnect idle stop solenoid (if equipped). Adjust hex screw (in end of solenoid) or low idle speed screw to obtain lower RPM. Connect wire to idle stop solenoid. Open throttle to extend solenoid. Turn solenoid to obtain higher specified idle RPM.

**151" (Without A/C)** - Disconnect idle stop solenoid and adjust carburetor idle speed screw to obtain specified "Curb Idle" RPM. Reconnect solenoid and adjust solenoid plunger contact screw to obtain specified "Solenoid RPM". Adjust ignition timing then recheck idle speeds.

**151" (With A/C)** - Adjust idle speed and ignition timing as previously described under Without A/C. Disconnect air conditioning wide open throttle override switch connector on accelerator linkage bracket. Set A/C in the "ON" position. Open throttle allowing solenoid plunger to extend, then adjust solenoid screw to obtain specified "Solenoid RPM". Reconnect A/C override switch and turn A/C off.

## IGNITION TIMING

**NOTE:** Some engines may incorporate a magnetic timing probe hole. This is for use with special electronic timing equipment. Refer to equipment manufacturer's instructions for correct procedures.

- 1) Timing is checked and adjusted with engine at normal operating temperature, choke open and air conditioning "OFF".

# 1975-79 TUNE-UP PROCEDURES

## Pontiac 4-Cylinder (Cont.)

### IDLE SPEED (RPM)

Application	Curb Idle	Solenoid Energized
<b>1975-76</b>		
1-Bbl.		
Man. Trans. ....	700	1000
Auto. Trans. ....	550	750
2-Bbl.		
Man. Trans. ....	700	1000
Auto. Trans. ....	600	750
<b>1977</b>		
140"		
Man. Trans.		
Federal .....	700	1250
Calif. & High Alt. ....	800	1250
Auto. Trans.		
Federal .....	650	850
Calif. & High Alt. ....	700	850
151"		
Man. Trans.		
With A/C .....	500	1200
Without A/C .....	500	1000
Auto. Trans.		
With A/C .....	650	850
Without A/C .....	500	650
<b>1978</b>		
Man. Trans.		
With A/C .....	1000	1200
Without A/C .....	500	1000
Auto. Trans.		
With A/C .....	650	850
Without A/C .....	500	650
<b>1979</b>		
Man. Trans.		
Federal		
With A/C .....	900	1250
Without A/C .....	500	.....
Calif.		
With A/C .....	1000	1200
Without A/C .....	500	.....
Auto. Trans.		
With A/C .....	650	850
Without A/C .....	500	.....

### IDLE MIXTURE

#### TACHOMETER (LEAN DROP) PROCEDURE

- 1975-77 Vehicles** – 1) Set hot (slow) idle speed, ignition timing and idle stop solenoid. Set parking brake. Disconnect and plug vacuum hose to distributor advance and vapor canister.
- 2) Warm engine to operating temperature. Turn A/C off. Place auto. trans. in Drive or man. trans. in Neutral. De-energize idle stop solenoid on man. trans. only.
- 3) Remove tab on mixture screw limiter(s). Lightly seat mixture screw(s) and back out 5 turns. Adjust idle speed to higher value. See IDLE MIXTURE (RPM) table. Back out mixture screw(s) until highest idle speed is obtained.
- 4) Adjust idle speed again, until higher value is obtained. Turn in (lean) mixture screw(s) 1/2 turn at a time until lower idle speed is obtained.

### IDLE MIXTURE (RPM)

Application	Higher	Lower
<b>1975-76</b>		
1-Bbl.		
Man. Trans. ....	825	700
Auto. Trans. ....	850	750
2-Bbl.		
Man. Trans. ....	820	700
Auto. Trans. ....	830	750
<b>1977</b>		
140"		
Man. Trans.		
Federal .....	780	700
Calif. & High Alt. ....	880	800
Auto. Trans.		
Federal & Calif. ....	680	650
High Alt. ....	730	700
151"		
Man. Trans. ....	1250	1000
Auto. Trans. ....	685	650

### PROPANE ENRICHMENT PROCEDURE

**NOTE: All carburetors have the idle mixture screws sealed with a metal plug. This plug must be removed before any adjustments can be made.**

To remove the mixture adjustment plug, proceed as follows:

- Remove carburetor. Turn upsidedown and place on a holding fixture.
- Place a punch between two locator marks on throttle body beneath mixture screw plug and break out throttle body to gain access to plug.
- Use punch to drive out plug. If plug shatters, remove loose pieces.
- Reinstall carburetor on engine. Use a thin wall 3/16" deep socket to make mixture adjustments.

- 1978-79 Federal Vehicles** – 1) Mixture is checked or adjusted with engine at normal operating temperature, choke open and air conditioning "OFF" (if equipped).
- 2) Disconnect and plug hoses as directed on the Emission Control Tune-Up Decal in engine compartment. Set parking brake and block drive wheels.
- 3) Connect a tachometer to engine. Disconnect vacuum advance hose to distributor and set ignition timing as previously outlined. Reconnect vacuum advance hose.
- 4) Disconnect crankcase ventilation hose from air cleaner. Insert a "T" between carburetor hose and PCV valve and connect open end of "T" fitting to propane supply.

**NOTE: Propane bottle must remain in a vertical position.**

- 5) Slowly open propane control valve until maximum engine RPM is reached with automatic transmission in Drive and manual transmission in Neutral.

**NOTE: Too much propane will cause engine speed to drop.**

- 6) Watch propane flow meter to make sure propane bottle is full. With propane flowing, adjust idle speed screw to the enriched RPM. See PROPANE ENRICHED IDLE MIXTURE RPM table.
- 7) Readjust propane flow to make sure of maximum engine speed. Adjust idle speed RPM if necessary. Turn off propane.
- 8) Place transmission in Neutral and run engine at 2000 RPM for 30 seconds. Place automatic transmission in Drive and manual transmission in Neutral.
- 9) Check idle speed. If idle speed is to specification on Emission Control Tune-Up Decal, idle mixture is correct. Proceed to step 14).

# 1975-79 TUNE-UP PROCEDURES

## Pontiac 4-Cylinder (Cont.)

10) If idle speed is too low, carefully remove caps from mixture screws. Back screws out  $\frac{1}{8}$  turn at a time until specified idle speed is obtained.

11) If idle speed is too high, carefully remove caps from mixture screws. Turn screws in  $\frac{1}{8}$  turn at a time until specified idle speed is obtained.

**NOTE: It may be necessary to remove air cleaner to reach idle mixture screws. Reinstall air cleaner to check idle speed.**

12) Turn propane on again and check maximum engine idle speed. If idle speed differs from specification, readjust idle speed to enriched RPM with propane flowing.

13) Turn off propane and accelerate engine to 2000 RPM for 30 seconds. Recheck idle speed. If idle speed is not to specification, repeat procedure starting with step 10).

14) If idle speed is correct, turn engine off and remove propane equipment. Connect crankcase ventilation hose and all other hoses disconnected.

**1978-79 California Vehicles - 1)** Mixture is checked or adjusted with engine at normal operating temperature, choke open and air conditioning "OFF".

2) Disconnect and plug hoses as directed on Emission Control Tune-Up Decal in engine compartment. Set parking brake and block drive wheels.

3) Connect a tachometer to engine. Disconnect vacuum advance hose to distributor and set ignition timing as previously outlined. Reconnect vacuum advance hose.

4) Disconnect control vacuum hose at carburetor and plug. Remove idle mixture screw plug cup. Remove soft lead plug covering idle needle diaphragm adjusting screw.

5) Lightly seat idle mixture screw and back out 2 turns. Turn in idle needle diaphragm adjusting screw until it is lightly seated.

**NOTE: Do not force needle into seat.**

6) Disconnect purge hose at charcoal canister. Install a vacuum "T" (Part No. 465994) in end of hose. Insert propane tool hose in large end of "T". Leave small end open to act as a calibrated air bleed.

7) With A/C off, start engine. Place automatic transmission in Drive and manual transmission in Neutral.

**NOTE: Propane bottle must remain in a vertical position.**

8) Slowly open propane bottle until maximum engine RPM is reached. Adjust idle speed screw until engine speed is 760 RPM with propane flowing.

9) Check propane adjustment again to make sure maximum RPM has been reached. If a higher engine speed is obtained, readjust engine speed to 760 RPM.

10) Turn propane off. Adjust idle mixture screw to obtain an engine speed of 600 RPM. Turn screw out to increase RPM and in to decrease RPM.

11) Place transmission in Neutral. Accelerate engine to 2000 RPM for 30 seconds. Place automatic transmission in Drive and manual transmission in Neutral. Repeat steps 8) through 10) to make sure maximum engine speed with propane flowing has been obtained.

12) Cap air bleed at "T". Remove propane connector from hose. Connect a vacuum gauge to the "T". Adjust idle speed to obtain 650 RPM.

13) Adjust idle needle diaphragm adjusting screw until vacuum gauge reads 2.5 in. Hg at 650 RPM. It is normal for vacuum to fluctuate. Midpoint of fluctuation should be 2.5 in. Hg.

14) Remove "T" and reconnect hose to charcoal canister. Reconnect other disconnected hoses. Install a new idle mixture screw plug and idle needle diaphragm screw plug.

### PROPANE ENRICHED IDLE MIXTURE RPM

Application	Enriched RPM
Federal	
Man. Trans. ....	940
Auto. Trans. ....	650
California	
Man. Trans. ....	615
Auto. Trans. ....	880

### COLD (FAST) IDLE RPM

Adjustment is made with engine at normal operating temperature. Transmission in Park or Neutral. Idle speed should be correctly adjusted, air cleaner installed and choke open. Disconnect and plug vacuum lines to EGR valve and distributor vacuum advance. Make sure air conditioning is "OFF". Place fast idle screw on 2nd step for 1975-76 140" with 2-Bbl. carb. or highest step of fast idle cam for all others. Adjust fast idle screw to obtain specified fast idle RPM.

### COLD (FAST) IDLE RPM

Application	Man. Trans.	Auto. Trans.
1975		
140" 1-Bbl. ....	2000	2200
140" 2-Bbl. ....	1600	1600
1976		
140" 2-Bbl. <sup>1</sup> .....	2200	2200
1977		
140" .....	2500	2500
151" .....	2400	2400
1978-79		
151"		
Federal .....	2200	2400
Calif. ....	2200	2200

<sup>1</sup> - Not adjustable on 1-Bbl. carb.

### AUTOMATIC CHOKE

1) On 1975-76 140" 1-Bbl. engines, remove choke rod from upper lever. Push choke rod down against stop and hold choke valve wide open. Align top of choke rod with bottom hole in lever. Bend rod or turn swivel to adjust.

2) On all others, loosen choke cover retaining screws. Rotate choke cover until mark on cover aligns with specified setting on choke housing. Tighten choke cover retaining screws.

### AUTOMATIC CHOKE SETTING

Application	Setting
1975	
2-Bbl. Auto. Trans. ....	4NR
2-Bbl. Man. Trans. ....	3NR
1976	
2-Bbl. Auto. Trans. ....	3NR
2-Bbl. Man. Trans. ....	2NR
1977	
2-Bbl. 140" .....	3NR
2-Bbl. 151" .....	4NR
1978	
Federal	
Auto. Trans. ....	2NR
Man. Trans. ....	1NR
Calif.	
Auto. Trans. ....	Index
1979	
Federal	
Auto. Trans. ....	2NR
Man. Trans. ....	1NR
Calif.	
Auto. Trans. ....	Index
Man. Trans. ....	2NR

# 1975-79 TUNE-UP PROCEDURES

## Pontiac 4-Cylinder (Cont.)

1-113

### FUEL PUMP

140" - Fuel pump is located in tank.

151" - Make all tests at idle speed. For pressure test, pinch off fuel return line (if equipped).

#### FUEL PUMP SPECIFICATIONS

Application	Specification
Pressure	
140" .....	3-4.5 psi
151" .....	5-6.5 psi
Volume .....	One pint in 30-45 seconds

### IGNITION

#### DISTRIBUTOR

All models are equipped with Delco-Remy - High Energy Ignition.

**NOTE: Module must be replaced as a unit. A liberal coat of silicone grease MUST be applied to the surface on which module will be mounted.**

**Other Data & Specifications** - Also see Delco Ignition Systems in DISTRIBUTORS & IGNITION SYSTEMS section.

#### IGNITION COIL

Application	Specification
Resistance	
Primary (at 75° F) .....	0-1.0 ohms
Secondary (at 75° F) .....	6000-30,000 ohms
Current Draw (Engine Running)	
1975-76 .....	.5-1.5 amps
1977-79 .....	4.5-5.0 amps
Coil Output	
At all engine speeds .....	25-35

### CARBURETION

#### CARBURETORS

Application	Model
140"	
1-Bbl. ....	Rochester 1-MV
2-Bbl. ....	Holley 5210-C
151"	
1977 .....	Holley 5210-C
1978	
Federal .....	Holley 5210-C
Calif. ....	Holley 6510-C
1979	
Federal .....	Rochester 2SE
California .....	Holley 6510-C

**Other Data & Specifications** - Also see Holley or Rochester Carburetors in FUEL SYSTEMS section.