

# 1975-79 TUNE-UP PROCEDURES

## Ford Motor Co. V8

1-79

### ENGINE IDENTIFICATION

#### VEHICLE IDENTIFICATION NUMBER

Engine can be identified by the fifth character of the Vehicle Identification Number (VIN), located on a plate attached to the left corner of the instrument panel, and visible through windshield.

#### VIN CODES

Application	Code
1975-78	
302" 2-Bbl. ....	F
351" M 2-Bbl. ....	<sup>1</sup> Q
351" W 2-Bbl. ....	H
400" 2-Bbl. ....	S
400" 4-Bbl. ....	A
460" 4-Bbl. Police ....	C
1979	
302" 2-Bbl. ....	F
351" 2-Bbl. ....	H
400" 2-Bbl. ....	S

<sup>1</sup> - Available in 1977 models only.

### TUNE-UP NOTES

**NOTE:** Due to running changes in production and emission standards, manufacturer recommends that specifications shown on engine compartment Emission Control Tune-Up Decal be used in all instances.

**NOTE:** The EPA High Altitude emission standards apply to vehicles sold in certain areas outside of California which have an elevation above 4000 feet.

**NOTE:** When connecting a tachometer to Solid State Ignition (SSI) or Dura Spark ignition coil, install alligator clip on tachometer into "DEC" (TACH) cavity of coil.

**NOTE:** On vehicles equipped with catalytic converters, do not allow or create a condition of engine misfire in more than one cylinder for more than 30 seconds. Damage to converter may result due to loading converter with unburned air/fuel mixture.

### ENGINE COMPRESSION

Test compression with all spark plugs removed and engine at normal operating temperature. Crank engine through at least 5 compression strokes before recording reading.

#### ENGINE COMPRESSION

Application	Specification
Compression Ratio <sup>1</sup>	
302"	
California .....	8.1:1
Federal .....	8.4:1
351" W .....	8.3:1
351" M, 400" & 460" .....	8.0:1
Recommended Fuel .....	Unleaded (87 AKI Minimum)
Maximum Variation Between Cylinders .....	25%

<sup>1</sup> - Compression ratio on all 1975-76 engines is 8.0:1.

### VALVE CLEARANCE

Hydraulic Lifters - Zero lash.

### VALVE ARRANGEMENT

E-I-E-I-E-I-E-I (Left Bank, Front-to-Rear).

I-E-I-E-I-E-I-E (Right Bank, Front-to-Rear).

### SPARK PLUGS

#### SPARK PLUG TYPE

Application	Autolite No.
1975	
460" .....	ARF-52
All Others .....	ARF-42
1976	
302" (Early) .....	ARF-42
351" M & 400" (Calif.) .....	ARF-42
All Others .....	ARF-52
1977-78	
302"	
Calif. ....	ARF-52-6
Federal .....	ARF-52
351" M & 400" .....	ASF-52
351" W & 460" .....	ARF-52
1979	
302", 351" W & 400"	
Calif. ....	ASF-52-6
Federal .....	ASF-52
351" M .....	ASF-52

#### SPARK PLUG INSTALLATION

Application	Gap In. (mm)	Torque Ft. Lbs. (N.m)
1975-76 Models .....	.044 .....	10-15
1977-79 Models .....	.050 <sup>1</sup> .....	10-15 <sup>2</sup>

<sup>1</sup> - Spark plug gap on California models is .060".

<sup>2</sup> - Tighten spark plugs to 5-10 ft. lbs. on 1978 Ford, Lincoln, LTD II, Thunderbird, and Mark V models.

### HIGH TENSION WIRE RESISTANCE

1) Loosen wires from spark plugs by twisting spark plug boot carefully to loosen seal on plug. Remove wires by pulling on plug boot. Remove distributor cap from distributor, leaving wires connected to cap.

**NOTE:** DO NOT disconnect wires from distributor cap unless replacement is necessary.

2) Using an ohmmeter, check resistance of each wire by connecting one ohmmeter lead to spark plug terminal and other lead to distributor cap insert. If any wire has more than 5000 ohms resistance per inch, remove wire from cap and recheck. If resistance still exceeds 5000 ohms per inch, replace wire.

**NOTE:** Whenever a high tension wire is disconnected, the interior of spark plug terminal boot must be coated with dielectric silicone grease before wire is reattached.

### DISTRIBUTOR

Models are equipped with Solid State Ignition (SSI), Dura-Spark Ignition, or Electronic Engine Control I (EEC I) system. No adjustments are required. Some 1978-79 302" engines may use a bi-level distributor.

On bi-level distributors, numbers corresponding to spark plug wires are molded into cap for identification. Due to design, however, the wires are NOT arranged in firing order.

# 1975-79 TUNE-UP PROCEDURES

## Ford Motor Co. V8 (Cont.)

Spark plug connections, inside distributor cap, are shown by inner ring of numbers. Outer numbers are for future applications. See Fig. 1 and 2. Actual firing order (1-5-4-2-6-3-7-8 or 1-3-7-2-6-5-4-8) is found on top of intake manifold.

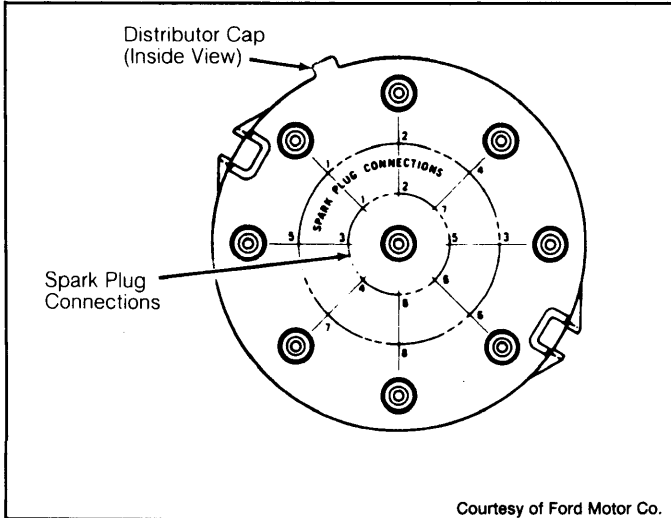

Fig. 1: 1978-79 Bi-Level Distributor Spark Plug Connections

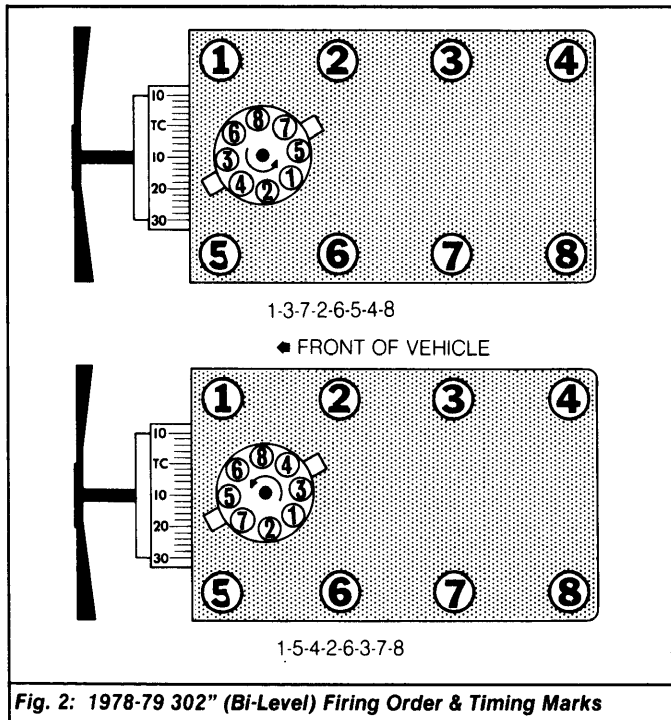

Fig. 2: 1978-79 302" (Bi-Level) Firing Order & Timing Marks

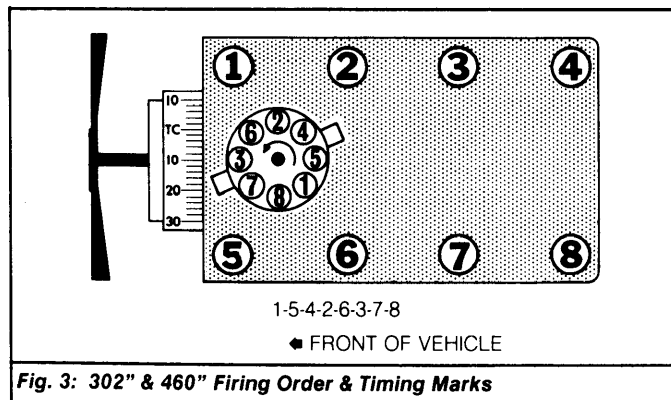

Fig. 3: 302" & 460" Firing Order & Timing Marks

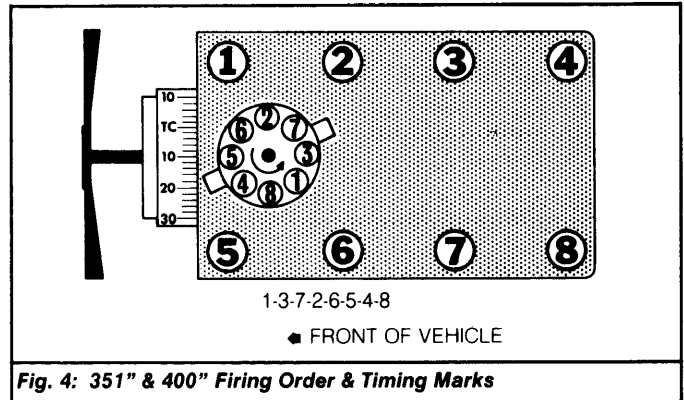

Fig. 4: 351" & 400" Firing Order & Timing Marks

### IGNITION TIMING

**NOTE:** If the Dura-Spark two-piece distributor cap must be removed, first remove top portion, then rotor, and then bottom portion. If any spark plug wire is disconnected with this system, the connection must first be greased with silicone grease before wire is reattached.

**1975-77 Models** - Check or adjust ignition timing with engine at normal operating temperature, distributor vacuum hoses disconnected and plugged, and engine idling at 600 RPM.

**NOTE:** On 1975-76 models, see Emission Control Tune-Up Decal under hood for ignition timing specifications.

#### 1977 IGNITION TIMING SPECIFICATIONS (DEGREES BTDC@RPM)

Application	Specification
302"	
Cougar & Thunderbird	2@600
Granada & Monarch	1 2@600
All Others	2 6@600
351" M	
California	8@600
Federal	10@600
High Altitude	10@600
351" W	
Granada, Monarch & Versailles	4@600
All Others	14@600
400"	
California	6@600
Federal	3 8@600
High Altitude	10@600
460"	
Federal	4 16@600
High Altitude	18@600
Police Interceptor	16@600

- 1 - Ignition timing is 6°BTDC on manual transmission equipped models.
- 2 - Ignition timing is 8°BTDC on manual transmission equipped models.
- 3 - Ignition timing is 12°BTDC with Calibration No. 7-17B-R15; 10°BTDC with Calibration No. 7-17B-R16; 6°BTDC with Calibration No. 7-17C-R1 or 7-17C-R11.
- 4 - Ignition timing is 10°BTDC with Calibration No. 7-19A-R2 or 7-19A-R3.

**1978-79 Models** - 1) Clean surface of front damper and make a White mark on proper degree line on damper and pointer. Turn A/C off and de-energize throttle solenoid positioner (if equipped). Disconnect and plug vacuum lines from distributor. 2) If equipped with dual mode timing ignition module, disconnect the 3-pin switch assembly from ignition module.

# 1975-79 TUNE-UP PROCEDURES

## Ford Motor Co. V8 (Cont.)

### 1978 IGNITION TIMING SPECIFICATIONS (DEGREES BTDC@RPM)

Application	Specification
302"	
Cougar & Thunderbird	8@Curb Idle
Fairmont & Zephyr	
Calif.	12@Curb Idle
Federal	6@Curb Idle
High Alt.	16@Curb Idle
Ford & LTD II	
Calif.	12@Curb Idle
Federal	14@Curb Idle
High Altitude	16@Curb Idle
Granada & Monarch	
California	12@Curb Idle
Federal	12@Curb Idle
High Altitude	16@Curb Idle
Mustang II	
California	10@Curb Idle
Federal	24@Curb Idle
High Altitude	16@Curb Idle
Versailles	30@Curb Idle
351" M	
California	16@Curb Idle
Federal	9@Curb Idle
351" W	14@Curb Idle
400"	
California	16@Curb Idle
Federal	13@Curb Idle
460"	16@Curb Idle

- <sup>1</sup> - Ignition timing is 12°BTDC on manual transmission equipped models.
- <sup>2</sup> - Ignition timing is 10°BTDC on manual transmission equipped models.

### 1979 IGNITION TIMING SPECIFICATIONS (DEGREES BTDC@RPM) <sup>1</sup>

Application	Specification
302"	
California	
Versailles	<sup>2</sup> Nonadjustable
Decal AFG	<sup>2</sup> Nonadjustable
Decal AFR & AGD	6@500
All Others	12@500
Federal	
Versailles	<sup>3</sup> 30@625
Decal ABB	<sup>3</sup> 15@625
Decal AFH, AFJ, AEP & AER	6@500
Decal AFU	8@500
All Others	<sup>4</sup> 8@500
351" M	
California	14@800
Federal	12@800
351" W	
California	<sup>2</sup> Nonadjustable
Federal	15@800
Decal ADZ & AEV	10@800
Decal AGY & AGZ	<sup>2</sup> Nonadjustable
High Altitude	10@800
400"	
California	16@800
Federal	14@800
Decal AGE	16@800

- <sup>1</sup> - The "Decal" 3-letter designation may be found on lower right-hand side of Ford's Vehicle Emission Control Information Label, attached to engine valve cover.
- <sup>2</sup> - Engine cranking reference timing is 10°BTDC.
- <sup>3</sup> - Automatic transmission in Drive.
- <sup>4</sup> - Ignition timing is 12°BTDC on manual transmission equipped models.

3) On all models, connect timing light to No. 1 spark plug and a tachometer to engine. On Dura-Spark ignition systems, use only a clamp-on, inductive type timing light and tachometer compatible with this system.

4) With engine at normal operating temperature, adjust ignition timing to specification. If initial timing is within 2 degrees of specification, do not adjust timing. Reconnect 3-pin connector.

5) If more than 2 degrees off, loosen distributor hold down bolt. Adjust ignition timing to specifications by rotating distributor to align marks on damper and pointer. Tighten hold-down bolt and recheck timing.

6) For vehicles with dual mode timing ignition module, reconnect the 3-pin switch assembly connector to module and check its function.

## HOT (SLOW) IDLE RPM

### VEHICLE PREPARATION

**NOTE: Vehicle preparation is not required on 1975-77 models.**

**1978 Models - 1)** All vacuum hoses must remain installed to air cleaner. Air cleaner must be installed when checking RPM. Adjustments are made with engine at normal operating temperature.

**2)** Disconnect fuel evaporation purge hose at first point where vacuum hose can be disconnected. DO NOT disconnect hose at purge valve. Plug hose and vacuum port. On models equipped with 2700 VV carburetor, the accelerator pump lever lash must be adjusted after each RPM adjustment.

**1979 Models - 1)** Apply parking brake and block wheels. If equipped with automatic parking brake release, disconnect and plug vacuum line at parking brake. Leave all vacuum hoses attached to air cleaner assembly. Air cleaner must be installed when measuring engine speeds

**2)** Turn off all accessories. Start engine, bring to normal operating temperature, and turn off engine. Disconnect and plug fuel evaporative purge valve signal vacuum hose at first point of removal other than valve. Removal at valve could cause valve damage.

**NOTE: On 1979 models with 7200 VV carburetors (351" W engines), disconnect evaporative purge hose at intake manifold and plug hose. Disconnect and plug EGR vacuum signal hose at EGR valve.**

**3)** Check throttle and choke linkages for free movement. Correct as necessary. Connect tachometer and check curb idle speed. After service, stop engine and remove all test equipment.

**4)** Reconnect automatic parking brake release (if equipped) and reconnect fuel evaporative purge valve vacuum hose. Reinstall air cleaner. On 302" engines, be sure to reconnect the air injection dump valve vacuum hose.

### CURB IDLE SPEED

**1975-76 Models - 1)** With air cleaner removed and vacuum hoses plugged, check ignition timing and adjust if necessary. Reconnect distributor vacuum advance hose.

**2)** Disconnect and plug EGR valve vacuum hose. Remove spark delay valve (if equipped) and route primary vacuum hose directly to distributor vacuum advance. Leave distributor retard hose connected.

**3)** Place A/C system in "OFF" position. Check and adjust fast idle RPM. Place manual transmission in Neutral or automatic transmission in Drive. Adjust idle speed as follows:

**4)** On models without throttle stop solenoid, turn idle speed screw to obtain specified idle RPM. See Emission Control Tune-Up Decal under hood for curb idle speed specifications.

**5)** On 351" and 400" engines with throttle stop solenoid, energize solenoid to extend plunger. Adjust solenoid plunger contact screw to obtain higher specified RPM.

**6)** Next, collapse plunger into solenoid. Adjust lower idle RPM using screw located on throttle body. Open throttle and allow plunger to extend. Adjust dashpot to specifications.

# 1975-79 TUNE-UP PROCEDURES

## Ford Motor Co. V8 (Cont.)

7) On all other models, energize solenoid to extend plunger. Adjust solenoid plunger contact screw to obtain higher specified RPM. Disconnect electrical lead to de-energize solenoid. Adjust lower idle RPM using screw located on throttle body. Open throttle and allow plunger to extend. Adjust dashpot to specifications.

**NOTE: On 1975-76 models, see Emission Control Tune-Up Decal under hood for curb idle speed specifications.**

**1977 Models With 2150 & 4350 Carburetors** - 1) With engine at normal operating temperature, parking brake set and drive wheels blocked, connect tachometer to engine. Remove air cleaner and plug vacuum hoses to air cleaner. Turn off all accessories.

2) On models with throttle solenoid or solenoid/dashpot, collapse solenoid plunger by forcing throttle lever against plunger. Check solenoid de-energized RPM and adjust to specifications by turning throttle adjustment screw.

3) On 4-barrel carburetor, set fuel bowl vent clearance as follows: adjust clearance between tip of adjustment screw on bowl vent arm and tang on accelerator pump drive lever to .001-.003", then turn adjustment screw one full turn clockwise.

**NOTE: On 4-barrel carburetors, the fuel bowl vent clearance must be adjusted before adjusting curb idle speed. On models equipped with 4-wheel disc brakes, disc brakes must be applied while adjusting curb idle speed.**

4) On all models, run engine at 2500 RPM for 15 seconds. Allow engine to return to curb idle and place automatic transmission in Drive. Check curb idle RPM and adjust to specification.

5) If specified curb idle speed cannot be obtained on dashpot equipped models, ensure clearance exists between dashpot plunger and throttle lever. If curb idle speed adjustment is required, check and adjust dashpot clearance.

6) On all models, install air cleaner. Recheck curb idle RPM and adjust if necessary. Final curb idle speed must be checked with air cleaner installed.

**1977 Models With 2700 VV Carburetor** - 1) With engine at normal operating temperature, parking brake set and drive wheels blocked, connect tachometer to engine.

2) If equipped, remove TVS vacuum hoses at air cleaner and install a by-pass in hoses removed. On all models, remove air cleaner and vacuum lines removed from air cleaner. Turn off all accessories.

3) On models with throttle solenoid or solenoid/dashpot assembly, run engine at 2500 RPM for 15 seconds. Place automatic transmission in Drive. Check curb idle RPM and adjust throttle solenoid if necessary.

4) Collapse solenoid plunger and check solenoid de-energized RPM. If necessary, adjust throttle stop screw to obtain specified solenoid de-energized RPM. After adjustments are completed, check accelerator pump lever lash adjustment.

**1977 IDLE SPEED (RPM) SPECIFICATIONS**

Application	Curb Idle	Solenoid De-Energized
302"		
Man. Trans. ....	800	500
Auto. Trans. ....	650	500
351" M		
Calif. ....	600	500
351 W" ....	625	550
All Others ....	650	500
400" ....	625	500
460"		
Federal ....	650	525
High Alt. ....	600	500
Police ....	700	525

5) On all other models, run engine at 2500 RPM for 15 seconds. Place automatic transmission in Drive. Check curb idle RPM and adjust to specifications by turning throttle adjustment screw. After adjustment is completed, check dashpot and accelerator pump lever lash adjustments.

**1978 Models With 2-Barrel Carburetor** - 1) On models without idle speed solenoid, adjust throttle stop screw until specified curb idle RPM is obtained. Ensure screw is against stop. Dashpot (if equipped) clearance must be checked and adjusted. Collapse dashpot plunger and check clearance between plunger and pad on throttle lever.

2) On models with idle speed solenoid but without A/C, turn long screw on solenoid mounting bracket to obtain specified curb idle RPM. With engine running, force throttle lever pad against solenoid plunger. Now adjust throttle stop screw until specified solenoid de-energized RPM is obtained.

3) On models with A/C, place A/C control lever in the "ON" position. Open throttle slightly to allow solenoid plunger to extend. Release throttle. Disconnect A/C compressor clutch lead.

4) To adjust A/C on RPM, turn long screw on solenoid mounting bracket to obtain specified A/C on RPM. Move A/C control lever to the "OFF" position. To adjust A/C off RPM, adjust throttle stop screw until specified RPM is obtained. Reconnect A/C compressor clutch lead.

**1978 Models With 4-Barrel Carburetor** - 1) On non-A/C models (except police interceptor), the throttle solenoid is non-functional. Adjust throttle stop screw until specified RPM is obtained.

2) On police interceptor models, turn long screw on solenoid mounting bracket to obtain specified curb idle RPM. With engine running, force throttle lever pad against solenoid plunger. Now adjust throttle stop screw until specified solenoid de-energized RPM is obtained.

3) On A/C equipped models (except police interceptor), place A/C control lever in the "ON" position. Open throttle slightly to allow solenoid plunger to extend. Release throttle. Disconnect A/C compressor clutch lead.

4) To adjust A/C on RPM, turn long screw on solenoid mounting bracket to obtain specified A/C on RPM. Move A/C control lever to the "OFF" position. To adjust A/C off RPM, adjust throttle stop screw until specified RPM is obtained. Reconnect A/C compressor clutch lead.

**1978 IDLE SPEED (RPM) SPECIFICATIONS**

Application	Curb Idle	Solenoid De-Energized
302"		
Cougar, Ford, LTD II & Thunderbird .....	650	700
Fairmont, Granada, Monarch & Zephyr Calif. ....	600	700
Fed. & High Alt. ....	600	600
Mustang		
Man. Trans. ....	900	900
Auto. Trans. ....	700	700
Versailles ....	625	500
351" M		
Calif. ....	650	500
Federal ....	675	500
351" W ....	600	500
400" & 460" ....	650	500

**1979 Models With 2150 Carburetor** - 1) Place A/C selector lever in the "OFF" position. Bring engine to normal operating temperature, open choke plate fully, and place shift lever in specified gear.

2) On 302" engines, connect air injection system dump valve to manifold vacuum, plugging or capping original port. On all models, run engine at 2500 RPM for 15 seconds in Neutral (manual transmission) or Park (automatic transmission).

# 1975-79 TUNE-UP PROCEDURES

## Ford Motor Co. V8 (Cont.)

- 3) Allow engine to return to idle. Check curb idle speed within 15 to 45 seconds. Repeat procedure 3 times or until idle speed stabilizes. If average speed is not within 50 RPM, adjust curb idle speed.
- 4) On models without solenoid devices, turn throttle stop adjustment screw until specified curb idle speed is obtained. Adjust dashpot clearance (if equipped). Turn engine off, collapse dashpot plunger and check clearance between plunger and throttle lever pad. Adjust to specifications.
- 5) On models with A/C Throttle Solenoid Positioner (TSP), turn throttle stop adjustment screw until specified A/C off RPM is obtained. To adjust A/C on RPM, move A/C selector to "ON" position. Open throttle and allow TSP plunger to fully extend. Release throttle and disconnect A/C compressor clutch lead.

**NOTE: Some engines may fluctuate in speed when checking. If this occurs, check speeds 3 times and calculate average speed.**

- 6) Check A/C off RPM. If not within specifications, turn long screw on TSP mounting bracket until correct RPM is obtained. Then, move A/C selector to "OFF" position and reconnect A/C compressor clutch lead.
- 7) On non-A/C 302" engines with anti-diesel Throttle Solenoid Positioner (TSP), adjust solenoid positioner by rotating long screw on TSP mounting bracket to set curb idle speed. To check TSP off RPM, run engine and collapse TSP plunger by forcing throttle lever pad against plunger. Turn throttle stop adjustment screw until specified TSP off RPM is obtained.

### 1979 CURB IDLE SPEED SPECIFICATIONS

Application	<sup>1</sup> A/C Off RPM	A/C On RPM
<b>302"</b>		
Calif.		
Auto. Trans. ....	600	675
Decal ACU & AFG .....	625	625
Decal AFR & AGD .....	550	625
Federal		
Man. Trans. ....	800	875
Auto. Trans. ....	600	675
Decal AEP, AER, AFH & AFJ .....	550	625
Decal AAA & ABB .....	625	625
<b>351" M</b>		
Federal .....	600	650
Calif. ....	600	650
<b>351" W</b>		
Calif. ....	620	675
Federal		
Decal ABV & ADZ .....	600	650
Decal AGY & AGZ .....	550	640
Decal ACK .....	600	650
<b>400"</b>		
Calif.		
Auto. Trans. ....	650	675
Decal AGE .....	600	650
Federal .....	600	675

<sup>1</sup> - Non-A/C models same as A/C off RPM. On vehicles with A/C and TSP, de-energize A/C compressor clutch. Manual transmission in Neutral, automatic transmission in Drive.

- 1) Place A/C selector lever in "OFF" position. Warm engine to normal operating temperature and fully seat cold enrichment rod. Place shift lever in specified gear.
- 2) Before each idle speed check, run engine at 2500 RPM for 15 seconds and then permit engine to return to idle. Measure idle RPM within 15 seconds to 2 minutes. Repeat speed checks 3 times and use average of speeds obtained.
- 3) On Versailles, adjust curb idle adjustment screw counterclockwise to specified RPM if RPM is too high. If too low, shut off engine

and turn curb idle adjustment screw one full turn clockwise, restart engine and recheck curb idle speed.

- 4) On non-A/C equipped models, or to check A/C off RPM on models with or without VOTM or solenoid/VOTM device, place shift lever in Drive. Turn A/C to the "OFF" position, and check engine RPM. Turn throttle stop screw to adjust idle speed. Cycle throttle to check repeatability within  $\pm 50$  RPM.
- 5) To check A/C on RPM on models with solenoid/VOTM device, turn A/C to the "ON" position. Place shift lever in Drive, disconnect A/C compressor clutch lead, and check engine RPM. To adjust, turn screw at rear of solenoid/VOTM device. Cycle throttle to check repeatability within  $\pm 50$  RPM. Reconnect A/C clutch lead
- 6) To check A/C on RPM on models with VOTM and no solenoid/VOTM device, see SECONDARY FAST IDLE, (1979 MODELS WITH 2700 VV CARBURETOR) in this article.

### 1979 TSP OFF IDLE SPEED SPECIFICATIONS

Application	TSP Off RPM <sup>1</sup> $\pm 50$ RPM
<b>302"</b>	
Decal AEP, AER, AFH & AFJ .....	625
California <sup>1</sup>	
Auto. Trans. ....	700
Decal ACU .....	700

<sup>1</sup> - With VOTM device.

**1979 Models With 7200 VV Carburetor** - 1) On models with cold start VOTM, bring engine to normal operating temperature. Turn throttle stop adjustment screw until specified curb idle RPM is obtained. Cycle throttle to check repeatability within  $\pm 50$  RPM.

- 2) On non-A/C models or to check A/C off RPM, turn A/C to "OFF" position. Start engine and turn throttle stop adjustment screw until specified curb idle RPM is obtained.
- 3) With engine off, collapse dashpot plunger and check clearance between plunger and throttle lever pad. Adjust if not to specifications. Cycle throttle to check repeatability within  $\pm 50$  RPM. Shut engine off and recheck dashpot clearance. Readjust if necessary. Adjust accelerator pump lever lash.

**NOTE: For accelerator pump lever lash adjustment procedure, see ACCELERATOR PUMP LEVER LASH ADJUSTMENT in this article.**

### IDLE MIXTURE

**NOTE: All vehicles may use only one or more methods of idle mixture adjustment. Use appropriate idle mixture procedure.**

### EXHAUST GAS ANALYZER PROCEDURE

**1975 Non-Catalytic Converter Equipped Models & V8 Partial-Flow Catalytic Converter Equipped Models** - 1) With engine at normal operating temperature, ensure timing and idle speed are set to specifications, and that idle limiter caps are in full rich position.

- 2) On vehicles equipped with Dual Spark Delay Valve (DSDV), disconnect and plug DSDV hose at manifold. Disconnect air cleaner-to-vapor canister hose and leave air cleaner installed. Disconnect air injection by-pass valve air hose at check valve.
- 3) Connect exhaust gas analyzer to vehicle. Place manual transmission in Neutral or automatic transmission in Drive. Increase engine RPM and allow throttle to return to idle position. Allow 10 seconds to pass before reading meter, but complete readings within 60 seconds.
- 4) If CO level is not within specifications on Emission Control Tune-Up Decal, remove air cleaner and idle mixture screw limiter caps. Adjust mixture screws as required to obtain correct CO level. Readjust idle speed if necessary (with air injection connected). After service, install Blue service limiter caps.

# 1975-79 TUNE-UP PROCEDURES

## Ford Motor Co. V8 (Cont.)

### OPTIMUM IDLE METHOD

**NOTE:** This procedure is to be used only when propane enrichment equipment is not available.

**1977 California Models** – 1) Connect tachometer and bring engine to normal operating temperature. Disconnect vapor canister hose from air cleaner. Remove idle mixture screw limiter caps using care not to bend screws. Run engine at 2500 RPM for 15 seconds.

2) If engine is equipped with air injection, proceed as follows: if equipped with one or 2 vacuum lines at side of dump valve, disconnect and plug lines. For valves with one line at top, check line to see if it is connected to intake manifold. If not, remove and plug line at dump valve and connect a slave line from dump valve vacuum fitting to an intake manifold vacuum fitting.

3) On all models, place automatic transmission in Drive. Adjust idle speed to specified curb idle RPM, plus the specified optimum idle speed range RPM. See Emission Control Tune-Up Decal under hood.

4) Adjust idle mixture screw to obtain maximum idle RPM, leaving mixture screw in the leanest position that will maintain maximum idle RPM. On 2700 VV carburetor, lean is counterclockwise (clockwise for all other carburetors).

5) Now turn mixture screw in the lean direction until specified curb idle RPM is obtained. Install a new limiter cap and recheck idle speed to ensure that cap installation did not change setting. Remove tachometer, reconnect vapor canister hose, and dump valve hose(s).

**1978 California Models** – 1) Air cleaner must be installed and all hoses attached. Apply parking brake and block wheels. Warm engine to normal operating temperature. Turn off engine and connect tachometer.

2) Trace canister purge valve vacuum hose from valve (on canister) to first connection. Disconnect hose at this point and plug all openings. DO NOT disconnect hose at purge valve. Disconnect canister purge hose from air cleaner and cap air cleaner opening. Disconnect and plug PVC system hose from air cleaner.

3) If engine is equipped with air injection, proceed as follows: if equipped with one or 2 vacuum lines at side of dump valve, disconnect and plug lines. For valves with one line at top, check line to see if it is connected to intake manifold. If not, remove and plug line at dump valve and connect a slave line from dump valve vacuum fitting to an intake manifold vacuum fitting.

**NOTE:** Some engines may experience normal RPM variances at idle, causing changes in engine speed measurements. If this occurs, use average speed.

4) Remove idle mixture screw limiter caps. Check curb idle speed and adjust if necessary. With engine idling, place transmission in specified position for propane enrichment check. See Emission Control Tune-Up Decal under hood. Adjust engine RPM to alternate idle speed change RPM as shown on decal. Note new idle speed on tachometer.

**NOTE:** If specification calls for "0", the above idle speed adjustment is not necessary. Also note that on automatic transmission equipped vehicles, transmission position may differ from that used for idle fuel mixture check. Be sure to use correct position.

5) Adjust idle mixture screw lean or rich and adjust idle speed screw until best idle is obtained at new idle speed RPM. Turn idle mixture screw clockwise (lean) until engine speed drops by specified alternate idle speed change RPM. Do not perform if specified change is "0".

6) Turn off engine. Install new limiter caps with tangs at maximum rich stop. Avoid changing mixture screw settings. If settings are changed, repeat procedure starting at step 4). Reconnect all hoses to original fittings. Remove test equipment.

### PROPANE ENRICHMENT PROCEDURE

**NOTE:** See Emission Control Tune-Up Decal under hood for Propane Enrichment specifications. Unless otherwise noted, the procedure for adjusting idle mixture on all carburetors is basically the same. For 2700 VV carburetors, substitute the words "venturi air by-pass screw" for "idle mixture screw(s)/limiter(s)". For IMPORTANT additional info. on 2700 and 7200 VV carburetors, see ADJUSTMENTS in Motorcraft 2700 and 7200 VV article in FUEL SYSTEMS section.

**1975 V8 Full-Flow Catalytic Converter Equipped Models & 1976-77 Models** – 1) With engine at normal operating temperature and idle speed correct, disconnect air cleaner-to-vapor canister hose. If applicable, disconnect PCV-to-air cleaner hose and plug air cleaner connection.

2) On models with air injection, proceed as follows: if equipped with one or 2 vacuum lines at side of dump valve, disconnect and plug lines. For valves with one line at top, check line to see if it is connected to intake manifold. If not, remove and plug line at dump valve and connect a slave line from dump valve vacuum fitting to an intake manifold vacuum fitting.

3) On all models, plug propane enrichment set (Rotunda T75L-9600-A) into air cleaner canister purge nipple. Place manual transmission in Neutral or automatic transmission in Drive.

4) With engine at idle speed, richen mixture (using bottled propane) to obtain maximum RPM. Continue to richen mixture until RPM drops. If RPM gain is within specifications, remove propane enrichment set and reconnect all hoses. Recheck idle, deceleration valve, and mixture settings.

5) If RPM gain was higher than specified, richen mixture screw (without injecting propane) until RPM increase is equal to the excess increase. For example, if increase was 80 RPM and desired increase is 50 RPM, adjust mixture screws rich for a 30 RPM increase. Readjust idle speed after each mixture screw adjustment.

6) If RPM gain was lower than specified, lean mixture screw (without injecting propane) until RPM decrease is equal to the RPM lag. For example, if increase was zero RPM and desired increase is 20 RPM, adjust mixture screw lean for a 20 RPM loss. Readjust idle speed after each mixture screw adjustment.

**1978 Models** – 1) Block wheels and apply parking brake. Connect tachometer to engine and bring engine to normal operating temperature. Be sure tachometer is compatible with Dura-Spark ignition system.

2) Disconnect and plug canister purge hose from air cleaner or PVC line tee. Disconnect crankcase vent hose from air cleaner and cap air cleaner hole. Check curb idle speed and reset if necessary.

3) If engine is equipped with air injection, proceed as follows: if equipped with one or 2 vacuum lines at side of dump valve, disconnect and plug lines. For valves with one line at top, check line to see if it is connected to intake manifold. If not, remove and plug line at dump valve and connect a slave line from dump valve vacuum fitting to an intake manifold vacuum fitting.

4) Plug propane enrichment set (Rotunda T75L-9600-A) into air cleaner canister purge nipple. With engine idling, slowly open propane bottle valve until engine speed reaches a maximum and then begins to drop (note maximum amount of speed increase). If speed will not drop, check propane supply. If necessary, repeat procedure with new propane bottle.

5) If speed increase is within specification, reconnect vacuum and emission control hoses to original fittings.

6) If increase is higher than specification, enrich mixture (without propane) by turning mixture screws clockwise in equal amounts until RPM increases as necessary. Repeat propane enrichment procedure.

7) When specification is met, remove propane enrichment set and reconnect all vacuum and emission hoses to original fittings. Set curb idle speed to specification. If curb idle speed was readjusted, check internal fuel bowl vent clearance. Turn off engine and disconnect tachometer.

# 1975-79 TUNE-UP PROCEDURES

## Ford Motor Co. V8 (Cont.)

- 1979 Models** - 1) Leave all vacuum hoses attached to air cleaner assembly when relocating air cleaner for carburetor adjustments. Air cleaner must be installed for engine speed checks.
- 2) Apply parking brake and block wheels. Disconnect automatic brake release and plug vacuum connection. Connect tachometer to engine. Be sure tachometer is compatible with Dura-Spark ignition system.
- 3) Disconnect and plug fuel evaporative purge return hose at engine. Disconnect fuel evaporative purge hose at air cleaner and plug nipple.
- 4) Disconnect flexible fresh air tube from air cleaner duct or adapter. Insert hose from propane enrichment set (Rotunda T75L-9600-A) into duct or fresh air tube.
- 5) For vehicles equipped with air injection, disconnect and plug hoses of dump valves equipped with two fittings. If dump valves have one fitting, remove and plug hose at valve. Connect slave hose to dump valve and intake manifold vacuum fittings.
- 6) Be sure idle mixture limiter(s) is set to maximum rich position (counterclockwise against stop). Check curb idle speed or A/C off RPM and set to specifications. With shift lever in Neutral, run engine at 2500 RPM for 15 seconds before each mixture check.
- 7) With engine idling at normal operating temperature, place transmission shift lever in Neutral for manual transmission or Drive for vehicles with automatic transmissions. Gradually open propane valve and watch for engine speed gain on tachometer. When speed reaches maximum and begins to drop off, note amount of speed gain.

**NOTE: If engine speed will not drop off, check propane supply. Repeat if necessary with new bottle.**

- 8) Compare measured speed gain to specifications. If idle mixture adjustment is necessary, adjust to reset RPM. If speed increase is within RPM gain specification, proceed to step 15).
- 9) If measured speed gain is zero RPM and minimum speed gain specification is zero RPM, proceed to step 12).
- 10) If measured speed gain is greater than specification, turn mixture screw(s) counterclockwise in equal amounts and repeat steps 6) through 8) until measured speed rise meets reset RPM specification. After final adjustment, proceed to step 15).
- 11) If measured speed gain is less than specifications, turn mixture screw(s) clockwise in equal amounts and repeat steps 6) through 8) until speed rise meets reset RPM specifications. After final adjustment, proceed to step 15).
- 12) If there is zero increase in RPM and the minimum speed gain specification is zero RPM, perform the following speed drop test. While watching tachometer, adjust mixture screw(s) clockwise by number of turns specified on Emission Control Tune-Up Decal. Note drop in engine speed.
- 13) If measured speed drop is equal to or drops off more than speed drop specification, return mixture screw(s) to maximum rich position or mixture screw(s) to position prior to adjustment. Then proceed to step 15).
- 14) If measured speed drop is less than the specified minimum, leave mixture screws(s) in adjusted position and repeat step 6) through 13).

**NOTE: For 2700 VV carburetors, connect a vacuum gauge (Rotunda T77L-9510-A) to vacuum tap on venturi valve cover. Check control vacuum. If not within specified limits turn venturi valve diaphragm adjusting screw clockwise to increase or counterclockwise to decrease. Remove vacuum gauge and check curb idle speed. Reset if necessary. Then check internal vent clearance, resetting if necessary.**

- 15) Check curb idle speed and remove all test equipment. Reconnect all components and reinstall air cleaner, if removed.

### COLD (FAST) IDLE RPM

**NOTE: Before making cold (fast) idle RPM adjustments, prepare vehicle as outlined under HOT (SLOW) IDLE RPM.**

- 1975-76 Models** - 1) Ensure engine is at normal operating temperature, hot (slow) idle RPM and idle mixture are correctly adjusted. With engine off, remove air cleaner. Plug air cleaner vacuum hose at intake manifold. Disconnect and plug distributor primary diaphragm and EGR valve vacuum hoses.
- 2) Start engine. Open throttle and rotate fast idle cam until fast idle adjustment screw rests on highest step of fast idle cam. Rotate fast idle cam back until fast idle screw rests on specified cam step. Turn fast idle adjustment screw to obtain specified RPM.

#### 1975-76 FAST IDLE RPM SPECIFICATIONS

Application	Cam Step	RPM
302"		
Man. Trans. ....	Highest .....	2000
Auto. Trans. ....	Highest .....	2100
351" M		
Calif. ....	Kickdown .....	1150
Federal .....	Kickdown .....	1350
351" W		
Granada <sup>1</sup> .....	Kickdown .....	2000
All Others .....	Kickdown .....	1400
400" <sup>2</sup>		
Calif. ....	Kickdown .....	1400
Federal .....	Kickdown .....	1350
460" .....	Kickdown .....	1350

<sup>1</sup> - 1976 Federal models only.

<sup>2</sup> - On 1975 models, set fast idle to 1500 RPM.

- 1977 Models** - 1) With engine at normal operating temperature, remove air cleaner and plug vacuum lines. Remove spark delay valve (if equipped). Route distributor vacuum advance hose directly to the advance side of the distributor.
- 2) Disconnect and plug fuel deceleration valve hose (if equipped) at carburetor. Remove and plug EGR vacuum line at EGR valve. Turn off all accessories.
- 3) With choke valve fully open, place fast idle adjustment screw on kickdown step (on highest step on 302") of fast idle cam. Adjust screw until specified fast idle RPM is obtained. Reconnect all vacuum hoses, reinstall spark delay valve and fuel deceleration valve (if equipped).
- 1978 Models** - 1) On models with 2700 VV carburetors, remove and plug distributor vacuum advance hose. On all other models, remove spark delay valve from system by attaching distributor vacuum advance hose directly to advance side of distributor.
- 2) On all models, trace EGR signal vacuum advance hose from EGR to carburetor. If an EGR/PVS valve or cold weather modulator is located in hose, disconnect EGR hose at EGR valve and plug hose. If no EGR/PVS valve or cold weather modulator is found, leave vacuum hose connected to EGR valve.
- 3) With engine running at normal operating temperature, open choke plate fully or fully seat cold enrichment rod (2700 VV carburetor). Place shift lever in Neutral (manual transmission) or Park (automatic transmission). Run engine at 2500 RPM for 15 seconds. Then place fast idle lever on specified step of fast idle cam.
- 4) Allow engine speed to stabilize for 15 seconds to 2 minutes and measure fast idle RPM. Repeat procedure 3 times and adjust if not within 100 RPM of specification.
- 5) When specified speed is obtained, turn off engine and reconnect vacuum hoses previously removed. Be sure to reinstall spark delay valve if removed from system.

# 1975-79 TUNE-UP PROCEDURES

## Ford Motor Co. V8 (Cont.)

### 1977-78 FAST IDLE RPM SPECIFICATIONS

Application	RPM
302"	
Man. Trans. ....	2700
Auto. Trans. ....	2100
351" M	
California .....	1150
All Others .....	1350
351" W .....	1400
400"	
California .....	1350
All Others .....	1400
460" .....	1350

<sup>1</sup> - Set to 2000 RPM on Federal Granada and Monarch.

**1979 Models With 2700 VV Carburetor - 1)** Disconnect EGR vacuum hose at EGR valve and plug hose. Disconnect and plug advance side vacuum line to distributor on all models except Versailles. Adjust cold (fast) idle RPM. See 1979 MODEL FAST IDLE ADJUSTMENT in this article to complete procedure.

**1979 Models With 2150 Carburetor - 1)** Remove spark delay valve and route distributor vacuum advance hose directly to advance side of distributor.

**2)** On 302" engines with EGR/PVS valve or cold weather modulator, disconnect EGR hose at EGR valve and plug hose. If not equipped with EGR/PVS valve or cold weather modulator, DO NOT detach EGR vacuum hose.

**NOTE: On California 302" engine, disconnect EGR vacuum hose at EGR valve. Plug hose. Disconnect and plug both vacuum lines to distributor. Using a slave vacuum hose, connect distributor retard diaphragm to manifold vacuum.**

**3)** On all engines except 302" engine, retrace EGR signal vacuum hose from EGR/PVS, making sure there is no other vacuum connection between EGR/PVS and carburetor. If none exists, disconnect and plug hose at EGR valve.

**4)** If another connection exists, leave EGR vacuum hose connected. If not equipped with EGR/PVS do not detach EGR vacuum hose. Adjust cold (fast) idle RPM. See 1979 MODEL FAST IDLE ADJUSTMENT in this article to complete procedure.

**5)** On 302" engine, trace air injection dump valve vacuum hose from dump valve to carburetor. Disconnect hose nearest the carburetor. Plug original vacuum source and connect dump valve directly to manifold vacuum. Adjust cold (fast) idle RPM. See 1979 MODEL FAST IDLE ADJUSTMENT in this article to complete procedure.

**1979 Models With 7200 VV Carburetor -** Ensure EGR vacuum signal hose has been disconnected and plugged at EGR valve and evaporative emission purge hose has been disconnected from intake manifold and plugged. Adjust cold (fast) idle RPM. See 1979 MODEL FAST IDLE ADJUSTMENT in this article to complete procedure.

**1979 Model Fast Idle Adjustment - 1)** Run engine at normal operating temperature. Open choke plate fully (fully seat cold enrichment rod on vehicles with 2700 VV carburetor). Place manual transmission in Neutral or automatic transmission in Park.

**2)** Run engine at 2500 RPM for 15 seconds and then place fast idle lever on specified step of fast idle cam. Allow engine speed to stabilize (15 to 45 seconds for 302" engine; 15 seconds to 2 minutes for all others). Measure fast idle RPM.

**3)** Repeat step 2) three times. If average speed of 3 tests is not within 100 RPM of specifications, adjust cold (fast) idle RPM to specification. After adjustment, recheck fast idle RPM.

**4)** Turn engine off and reconnect vacuum hose(s) previously removed. Make sure that spark delay valve is installed, if removed. Stop engine and remove test equipment. Reconnect fuel evaporative purge valve signal hose. Reconnect air injection dump valve signal vacuum hose on 302" engine.

### 1979 FAST IDLE RPM SPECIFICATIONS <sup>1</sup>

Application	<sup>2</sup> RPM
302"	
California	
Auto. Trans. ....	1800
Decal ACU .....	2900
Decal AFG .....	2800
Decal AFR & AGD .....	1800
Federal	
Man. Trans. ....	2300
Auto. Trans. ....	2100
Decal AAA .....	1900
Decal ABB .....	3100
Decal AEP, AER, AFH & AFJ .....	1750
351" M	
California .....	2300
Federal .....	2200
351" W	
California .....	2100
Federal	
Decal ABV & ADZ .....	2200
Decal ACK .....	2100
Decal AGY & AGZ .....	2000
400"	
California	
Auto. Trans. ....	2200
Decal AGE .....	2300
Federal .....	2200

<sup>1</sup> - The "Decal" 3-letter designation may be found on lower right-hand side of Ford's Vehicle Emission Control Information Label, attached to engine valve cover.

<sup>2</sup> - With fast idle cam set on highest step.

## SECONDARY FAST IDLE

**1979 Models With 2700 VV Carburetor - 1)** On Versailles with VOTM or solenoid/VTOM, turn engine off. Disconnect and plug vacuum hose from vacuum operated throttle modulator and connect slave hose from engine manifold source to VOTM.

**NOTE: On Versailles models with ignition retard module, manifold vacuum source must be applied also to electric vacuum switch. On California 302" engine, disconnect EGR vacuum hose at EGR valve. Plug hose. Disconnect and plug both vacuum lines to distributor. Using a slave vacuum, connect distributor retard to manifold vacuum.**

**2)** Disconnect EGR valve actuator pressure hose at EGR valve. Start engine and depress throttle until VOTM plunger extends fully. Release throttle. With transmission in Drive, check VOTM fast idle RPM.

**3)** To adjust, loosen lock nut securing modulator, turn modulator until specified auxiliary fast idle RPM is obtained, and then tighten lock nut. Remove slave vacuum hose and reconnect system vacuum hose and pressure hose at EGR valve.

**4)** On all other models, the secondary idle RPM is controlled by engine coolant PVS. Systems provide intermediate fast idle speed during cold engine operation. Disconnect vacuum hose to VOTM. Using slave vacuum line, connect VOTM to manifold vacuum source.

**2)** Place transmission in Drive. Check engine RPM and adjust to specification, using bracket adjustment. Cycle throttle to check repeatability within  $\pm 50$  RPM. When RPM is correct, remove slave vacuum line(s), reconnect EGR and distributor vacuum lines.

**1979 Models With 7200 VV Carburetor - 1)** The VOTM or VOTM with dashpot provide secondary fast idle during cold engine operation. Operation is controlled by engine coolant temperature or time.

# 1975-79 TUNE-UP PROCEDURES

## Ford Motor Co. V8 (Cont.)

- 2) With A/C selector lever in "OFF" position, disconnect vacuum hose to VOTM or VOTM with dashpot. Using a slave vacuum line, connect VOTM or VOTM with dashpot to manifold vacuum.
- 3) Check RPM and adjust to specifications. To adjust VOTM, loosen lock nut securing VOTM to mounting bracket. Turn VOTM until desired RPM is reached and tighten lock nut.
- 4) To adjust VOTM with dashpot, turn adjusting screw on VOTM with dashpot mounting bracket until desired RPM is obtained. On all models, cycle throttle to check repeatability within  $\pm 50$  RPM. Remove slave vacuum line(s).

### ACCELERATOR PUMP LEVER LASH ADJUSTMENT

**NOTE:** Lash must be checked and adjusted, if necessary, each time curb idle RPM is adjusted on 2700 VV and 7200 VV Carburetors.

**1977 & 1979 Models With 2700 VV Or 7200 VV Carburetor** – Apply slight downward pressure on top of nylon nut located on accelerator pump to take up linkage free play. Using a feeler gauge, check lash clearance between top of accelerator pump stem and pump lever. Clearance should be .010". If not within specifications, adjust lash by turning nylon nut on accelerator pump rod.

**NOTE:** Some 1977-78 models with 302", 351", and 400" 2-barrel equipped engines may experience a warm engine hesitation. Conditions of warm engine hesitation during acceleration (see APPLICABLE CALIBRATIONS table), may be corrected by installing an accelerator pump piston cap (D7A7-6935-A on 1977 models, D8ZZ-9635-A on 1978 models). The condition can also be corrected by repositioning accelerator pump rod. Move rod one hole from present position toward outer end of lever.

#### APPLICABLE CALIBRATIONS

Model Year	Calibration No.
1977	7-14N-R13, 7-14A-R1, 7-14B-R1, 7-14B-R10, 7-14A-R10, 7-14C-R11, 7-17P-R13, 7-17P-R21, 7-17B-R15, 7-17P-R23, 7-17A-R11, 7-17B-R11 & 7-17C-R11
1978	8-10A-R0, 8-10B-R0, 8-31A-R0, 8-32B-R0, 8-32B-R11 & 8-11M-R-16

### DASHPOT ADJUSTMENT

**1977 Models** – Collapse dashpot plunger. Using a feeler gauge, check clearance between plunger and throttle lever pad. Dashpot plunger-to-throttle lever clearance should be .060". Adjust dashpot as necessary to obtain specified clearance.

### AUTOMATIC CHOKE

#### 1975-76 AUTOMATIC CHOKE SETTINGS

Application	Setting
351" M (Federal)	2NR
460"	2NR
All Others	3NR

#### 1977 AUTOMATIC CHOKE SETTINGS

Application	Setting
302"	
Mustang	3NR
High Altitude	1NR
All Others	Index
351" M	
California	Index
Federal	2NR
High Altitude	1NR
351" W	3NR
400"	
Federal	2NR
All Others	Index
460"	
Federal	2NR
High Altitude	2NL
Police Interceptor	2NR

#### 1978 AUTOMATIC CHOKE SETTINGS<sup>1</sup>

Application	Setting
302"	
Fairmont & Zephyr	4NR
Granada & Monarch	3NR
Mustang II	2NR
351" M	
California	3NR
351" W	
Cougar, Ford & LTD II	1NR
400"	
California	3NR

<sup>1</sup> – For models and engines not covered, see Emission Control Tune-Up Decal under hood.

#### 1979 AUTOMATIC CHOKE SETTINGS

Application	Setting
302"	
Ford & Mercury	
Federal	Index
Vesailles	Index
All Others	
Federal	
Man. Trans.	2NR
Auto. Trans.	3NR
California	Index
351" M	
Federal	3NR
Decal AGL	2NR
351" W	
Cougar & Thunderbird	
Federal	2NR
Mercury & Ford	
Federal	2NR
California	Index
351" W (Decal AEV & AGW)	1NR
400"	3NR

# 1975-79 TUNE-UP PROCEDURES

## Ford Motor Co. V8 (Cont.)

### FUEL PUMP

Check fuel pump at idle RPM with engine at normal operating temperature and transmission in Neutral.

#### FUEL PUMP SPECIFICATIONS

Application	Specification
Pressure	
460" (Police) .....	5.0-7.0 psi
All Others .....	6.0-8.0 psi
Volume (Minimum) .....	One pint in 20 seconds.

### IGNITION

#### DISTRIBUTORS

All 1975-76 models are equipped with Motorcraft Solid State Ignition (SSI). Most 1977-79 models are equipped with a Motorcraft Dura-Spark I or II ignition systems. The 1978-79 Versailles is equipped with an Electronic Engine Control I (EEC I) system.

**NOTE: Some 1979 Ford and Mercury 351" W engine equipped models use the Dura-Spark III ignition system.**

**Other Data & Specifications** - Also see Motorcraft Ignition Systems in DISTRIBUTORS & IGNITION SYSTEMS section.

#### IGNITION COIL

##### IGNITION COIL SPECIFICATIONS

Application	Specification
1975-77	
Primary Resistance (At 75°F)	
Dura-Spark I .....	0.5-1.5 Ohms
Dura-Spark II & SSI .....	1.0-1.2 Ohms
Secondary Resistance (At 75°F) .....	7000-13,000 Ohms
Resistor Wire (At 75°F) .....	1.3-1.4 Ohms
Coil Output (Minimum) .....	20,000 Volts
1978-79	
Primary Resistance (at 75°F)	
Dura-Spark I .....	.71-.77 Ohm
Dura-Spark II .....	1.13-1.23 Ohms
Secondary Resistance (at 75°F)	
Dura-Spark I .....	7350-8250 Ohms
Dura-Spark II .....	7700-9300 Ohms
Ballast Resistor Resistance (at 75°F)	
Dura-Spark I .....	Not Used
Dura-Spark II .....	1.05-1.15 Ohms
Coil Output (Minimum) .....	36,000 Volts

### CARBURETION

#### CARBURETORS

Application	Model
1975-76	
302", 351", 400" 2-Bbl. ....	Motorcraft 2150
460" 4-Bbl. ....	Motorcraft 4350
1977-78	
302" 2-Bbl.	
California .....	Motorcraft 2700 VV
Federal .....	Motorcraft 2150
351" & 400" 2-Bbl. ....	Motorcraft 2150
460" .....	Motorcraft 4350
1979	
302" 2-Bbl.	
California .....	Motorcraft 2700 VV
Federal	
Ford LTD, Mercury Marquis & Versailles .....	Motorcraft 2700 VV
All Others .....	Motorcraft 2150
351" W	
California	
Ford & Mercury .....	Motorcraft 7200 VV
High Altitude .....	Motorcraft 7200 VV
351" M & 400" .....	Motorcraft 2150

**Other Data & Specifications** - Also see Motorcraft Carburetors in FUEL SYSTEMS section.