

1975-79 TUNE-UP PROCEDURES

Chevrolet V6

1978-79 Chevrolet

ENGINE IDENTIFICATION

VEHICLE IDENTIFICATION NUMBER

Fifth character of Vehicle Identification Number (VIN), located on plate attached to top left side of instrument panel, is the engine code.

VIN CODES

Application	Codes
196" 2-Bbl.	C
200" 2-Bbl.	M
231" 2-Bbl.	A
231" 2-Bbl.	2

ENGINE IDENTIFICATION CODE

Engine code is located on right hand side of cylinder block, near water pump.

ENGINE CODES

Application	Code
1978	
196" 2-Bbl.	PC, PD
200" 2-Bbl.	CWA, CWB, CWC, CWD
231" 2-Bbl.	EA, OD, OF, OG, OH, OE, OK
1979	
196" 2-Bbl.	FA, FB, FC, FD, FE, FF, FG, FH
200" 2-Bbl.	DHA, DHB, DHC
231" 2-Bbl.	
VIN A	NA, NB, NC, NE, NF, NG, NH, NK NJ, NL, NM, RA, RB, RC, RF, RG, RJ, RW, RY, SJ, SK, SL, SM, SO, SP, SR, SS
VIN 2	RM, RN
VIN 3	RO, RP, RR, RS, RT, RU, RV

TUNE-UP NOTES

NOTE: In order to comply with emission standards, specifications shown on engine compartment Emission Control Tune-Up Decal must be used in all instances.

NOTE: The EPA High Altitude emission standards apply to vehicles sold in certain areas outside of California which have an elevation above 4000 feet.

NOTE: Before making a compression test or cranking engine with a remote starting switch, disconnect ignition switch "BATT" terminal lead at distributor.

CAUTION: Do not remove spark plug wires with engine running. High Energy Ignition (HEI) secondary voltage is higher than standard ignition systems and may inflict harmful electrical shock.

NOTE: Damage to HEI electronic module and/or ignition coil may result if "TACH" terminal, in distributor cap connector, is directly grounded.

ENGINE COMPRESSION

Test compression pressure with engine at normal operating temperature, all spark plugs removed and throttle and choke valves wide open.

ENGINE COMPRESSION SPECIFICATIONS

Application	Specifications
Compression Ratio	
196" 2-Bbl.	8.0:1
200" 2-Bbl.	8.2:1
231" 2-Bbl.	8.0:1
Recommended Fuel	Unleaded (87 AKI Minimum)
Compression Pressure	100 psi minimum
Maximum Variation Between Cylinders	30%

VALVE CLEARANCE

196" & 231" 2-Bbl.

Hydraulic Lifters - Zero lash.

200" 2-Bbl.

Hydraulic Lifters - One full turn down from zero lash.

VALVE ARRANGEMENT

E-I-E-I-E (Front-to-Rear, Left Bank).

E-I-E-I-E (Front-to-Rear, Right Bank).

SPARK PLUGS

SPARK PLUG TYPE

Application	AC NO.
196" 2-Bbl.	R46TSX
200" 2-Bbl.	R45TS
231" 2-Bbl.	¹ R45TSX

¹ - R46TSX may also be used.

SPARK PLUG INSTALLATION

Application	Gap	Torque
196" 2-Bbl.060"	15-25 ft. lbs.
200" 2-Bbl.045"	9-20 ft. lbs.
231" 2-Bbl.060"	15-25 ft. lbs.

HIGH TENSION WIRE RESISTANCE

Carefully remove ends of wire from spark plug and distributor. Using an ohmmeter, check resistance while gently twisting wire. If resistance is not to specification, or fluctuates from infinity to any value, replace wire.

WIRE RESISTANCE

Wire Length	Ohms (Maximum)
Under 24"	30,000
Over 24"	50,000

1975-79 TUNE-UP PROCEDURES Chevrolet V6 (Cont.)

DISTRIBUTOR

All models are equipped with High Energy Ignition (HEI) system. No adjustment is required.

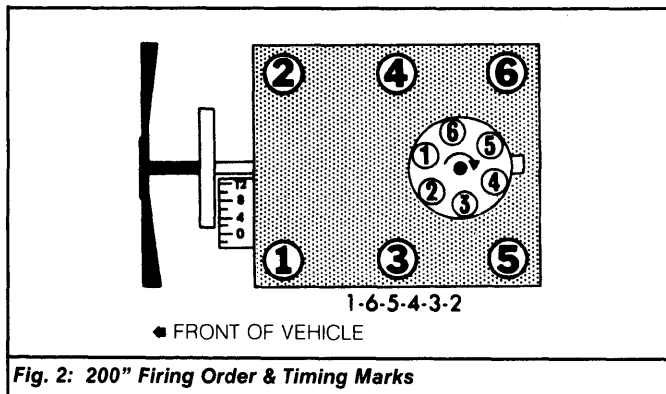
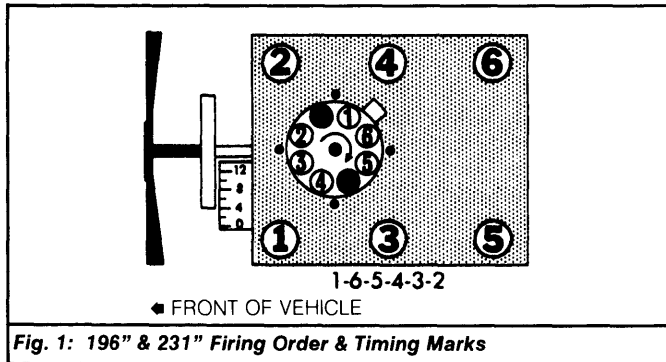

IGNITION TIMING

Check or adjust ignition timing with engine at normal operating temperature, choke fully open, air cleaner installed and air conditioning off. Disconnect and plug distributor vacuum advance hose and set timing with engine at specified RPM.

NOTE: Some engines may incorporate a magnetic timing probe hole. This is for use with special electronic timing equipment. Refer to the equipment manufacturer's instruction for correct procedures.

IGNITION TIMING SPECIFICATIONS (DEGREES BTDC@RPM)

Application	Man. Trans.	Auto. Trans.
1978		
196" 2-Bbl.	15@800	15@600
200" 2-Bbl.	8@700	8@600
231" 2-Bbl.	15@600	15@800
1979		
196" 2-Bbl.	15@800	15@550
200" 2-Bbl.	8@700	12@1200
231" 2-Bbl.	15@800	15@600

¹ - Set at 550 RPM on Federal models.

HOT (SLOW) IDLE RPM

NOTE: Idle speed adjustment procedures will vary with vehicle model and component application. Refer to Emission Control Tune-Up Decal in engine compartment for adjustment preparations, then proceed as follows:

1978-79 Vehicles Without Air Conditioning & Idle Speed Solenoid - Set idle speed adjusting screw on lowest step of fast idle cam. Turn idle speed screw to obtain specified curb idle RPM.

1978 Vehicles Without Air Conditioning, With Idle Speed Solenoid - With solenoid energized, open throttle slightly to allow solenoid plunger to fully extend. Adjust solenoid screw to obtain specified solenoid energized RPM. Disconnect lead at solenoid. With solenoid de-energized, adjust curb idle speed.

Vehicles With Air Conditioning - 1) Turn A/C off (solenoid de-energized) and place idle speed screw on low step of fast idle cam. Turn idle speed screw to obtain specified curb idle speed.

2) Disconnect A/C compressor electrical lead at compressor. Turn A/C on and place automatic transmission in Drive. Open throttle slightly to allow solenoid plunger to fully extend, then turn solenoid screw to obtain specified "Solenoid Energized" RPM. Reconnect compressor lead after adjustment.

IDLE SPEED (RPM) SPECIFICATIONS

Application	Curb Idle	Solenoid Energized
1978		
196" 2-Bbl.		
Man. Trans.		800
Auto. Trans.		600
200" 2-Bbl.		
Man. Trans.	800	700
Auto. Trans.	700	600
231" 2-Bbl.		
Man. Trans.	600	600
Auto. Trans.	800	800
1979		
196" 2-Bbl.		
Man. Trans.	800	600
Auto. Trans.	670	550
200" 2-Bbl.		
Man. Trans.	800	700
Auto. Trans.	700	600
231" 2-Bbl.		
Man. Trans.	800	600
Auto. Trans.		
Calif. ¹	800	600
Federal	670	550
High Alt.		600

¹ - Set solenoid energized speed to 620 RPM for 231" (VIN 2).

IDLE MIXTURE

NOTE: Idle mixture screws on all 1979 Rochester carburetors are covered by hardened steel plugs. Manufacturer recommends plug removal and mixture adjustment only after major carburetor overhaul, throttle body replacement or emissions failure.

MIXTURE SCREW PLUG REMOVAL

- 1) Remove carburetor from engine, invert carburetor and drain fuel. Place carburetor on a holding fixture with manifold side up.
- 2) Place a punch between the 2 locator marks on throttle body beneath mixture screw plug (manifold side) and breakout throttle body to gain access to plug.
- 3) Use a punch to drive out plug. If hardened steel plug shatters, remove loose pieces.
- 4) Repeat steps 2) and 3) to remove remaining plug (if equipped).

PROPANE ENRICHMENT PROCEDURE

All 1978-79 Models, Except 1979 231" (VIN 2) - 1) Ensure engine is at normal operating temperature, choke is fully open, and air conditioning off (if equipped). Set parking brake and block drive wheels. Disconnect and plug hoses as directed on Emission Control Tune-Up Decal under hood.

2) Connect tachometer to engine. Disconnect vacuum advance and set timing to specification. Reconnect vacuum advance. Disconnect

1975-79 TUNE-UP PROCEDURES

Chevrolet V6 (Cont.)

crankcase ventilation tube from air cleaner. Insert hose, with rubber stopper (J-26911), from propane valve into positive crankcase ventilation tube opening in air cleaner.

3) Propane cartridge must be in vertical position. Slowly open propane control valve until maximum engine speed is reached with automatic transmission in Drive or manual transmission in Neutral.

NOTE: Too much propane will cause engine speed to drop.

4) Observe propane flow meter to ensure propane cartridge is full. With propane flowing, adjust idle speed screw to the enriched RPM. Readjust propane flow to be certain of maximum engine speed and adjust idle speed if necessary.

5) Turn off propane. Place transmission in Neutral and run engine at 2000 RPM for 30 seconds. Place automatic transmission in Drive (manual transmission in Neutral). Check idle speed. If idle speed agrees with specification, idle mixture is correct. Proceed to step 8).

6) If idle speed is too low, back screws out 1/8 turn at a time until correct speed is reached. If speed is too high, turn mixture screws in 1/8 turn at a time until correct speed is reached.

NOTE: It may be necessary to remove air cleaner to reach idle mixture screws. Reinstall air cleaner to check idle speed.

7) Turn propane on again to check maximum engine idle speed. If speed is different from specification, readjust idle speed screw to enriched RPM with propane flowing. Turn off propane, place transmission in Neutral and accelerate engine to 2000 RPM for 30 seconds. Recheck idle speed. Idle speed should agree with specifications. If not, repeat procedure starting with step 6).

8) If idle is unusually rough, turn mixture screws in until lightly seated. Back screws out equally to previous position and rerun propane idle test starting with step 2). If idle is correct, turn engine off. Remove propane set up. Reconnect all hoses.

PROPANE ENRICHED RPM SPECIFICATIONS

Application	Enriched RPM
196" 2-Bbl.	
Man. Trans.	1000
Auto. Trans.	575
200" 2-Bbl.	
Man. Trans.	780-820
Auto. Trans.	620-640
231" 2-Bbl.	
Man. Trans.	840
Auto. Trans.	1615

¹ - Federal model specification is 575 RPM.

MIXTURE CONTROL ADJUSTMENT PROCEDURE

NOTE: The Computer Controlled Catalytic Converter System (C-4 System) used on the 1979 231" (VIN 2) engine, is sensitive to any change in mixture control adjustment which, if improperly set, can impair the ability of the system to maintain precise control of carburetor air/fuel mixture. Because of this, the previously used propane enrichment method of idle mixture adjustment may not be used when adjusting carburetors with the "C-4" system.

The following mixture control adjustment procedure should never be performed unless diagnosis indicates the carburetor to be the cause of a driver performance complaint or emission failure, or critical parts such as air horn, float bowl, throttle body, needle and seat, or float are replaced.

Idle Air Bleed Valve Adjustment, 1979 231" (VIN 2) Only - 1) Before adjusting the idle air bleed valve, mixture control solenoid adjustment must be checked and corrected as necessary. See Rochester E2ME 2-Bbl. Carburetor article in FUEL SYSTEMS section.

2) To adjust idle air bleed valve, set parking brake and block drive wheels. Disconnect and plug hoses as directed on Emission Control

Tune-Up Decal in engine compartment. Check ignition timing and adjust if necessary.

3) Connect a dwell meter to lead wire (Green connector) from mixture control solenoid in carburetor, then set dwell meter on 6-cylinder scale. Start engine and run at idle until normal operating temperature is reached and a varying dwell is noted on dwell meter.

NOTE: It is absolutely essential that engine is operated for a sufficient length of time to ensure the engine coolant sensor, and the oxygen sensor in the exhaust, are at full operational temperature.

4) Adjust curb idle speed, if necessary. With engine idling, observe dwell reading. If within, or varying between 25-35 degree range, no further adjustment is necessary. If dwell does not vary and/or falls outside the 10-50 degree range, see DIAGNOSTIC CIRCUIT CHECK flow chart of GM C-4 article in the COMPUTERIZED ENGINE CONTROL section.

5) If dwell meter varies between 10-24 degrees or 36-49 degrees, ensure no other causes of a rich or lean condition such as mechanical problems, weak ignition, poor fuel quality, vacuum leaks, flooding carburetor, emission control devices, PCV, canister purge control, etc. are present. If no other problems are found, perform the following:

6) With engine off, remove staking around plug covering idle air bleed valve and remove plug. Using a screwdriver that fully fits slot in valve, slowly turn valve up or down until dwell reading varies and falls within the 25-35 degree range, attempting to be at or as close to 30 degrees as possible.

CAUTION: Perform this step carefully. The idle air bleed valve is very sensitive in controlling air/fuel ratios and the valve should be turned only in 1/8 turn increments.

7) If after performing this adjustment, the dwell reading does not vary and is not within the 25-35 range range, it will be necessary to remove carburetor to gain access to the plugs covering the idle mixture needles and adjust the idle mixture. See IDLE MIXTURE ADJUSTMENT.

NOTE: See Mixture Screw Plug Removal in this article for removal of plugs covering idle mixture needles.

Idle Mixture Adjustment, 1979 231" (VIN 2) Only - 1) With idle mixture needle plugs removed, turn each idle mixture needle inward until lightly seated. Then, back out each mixture needle 2 1/2 turns.

2) Reinstall carburetor (without air cleaner and gasket). Start and run engine until fully warm, and repeat IDLE AIR BLEED VALVE ADJUSTMENT until dwell reading is varying and within specified limits.

3) If unable to achieve varying dwell and specified range, turn each mixture needle out an additional 1/2 turn. Then, reset idle air bleed valve to obtain dwell limit specifications.

4) If necessary, reset curb idle speed and fast idle speed to specifications. Disconnect dwell meter and tachometer. Unplug and reconnect vacuum hoses. Reinstall air cleaner and gasket.

COLD (FAST) IDLE RPM

1978 Models - 1) With engine at normal operating temperature and curb idle speed set to specifications, place fast idle cam follower on highest step of cam.

2) On manual choke equipped models, rotate fast idle cam clockwise to its farthest up position. On all models, bend cam follower tang in or out until specified fast idle RPM is obtained.

1979 Models - With engine at normal operating temperature, disconnect and plug vacuum hose at EGR valve. Position cam follower on cam step specified on Emission Control Tune-Up Decal and turn fast idle adjusting screw to obtain specified RPM.

1975-79 TUNE-UP PROCEDURES

Chevrolet V6 (Cont.)

FAST IDLE (RPM) SPECIFICATIONS

Application	Man. Trans.	Auto. Trans.
1978		
California	2000	2000
Federal	2000	2100
1979		
196" & 231"	2200	2200
200"	1300	1600

AUTOMATIC CHOKE

Loosen choke cover retaining screws. Position fast idle cam follower on highest step of fast idle cam. Rotate cover and coil assembly counterclockwise until choke valve just closes. Align index mark on cover with specified mark on choke housing. Tighten cover retaining screws.

AUTOMATIC CHOKE SETTING

Application	Setting
1978	
All Models	Index
1979	
196" 2-Bbl.	2NR
200" 2-Bbl.	
Man. Trans.	1NL
Auto. Trans.	Index
231" 2-Bbl.	
High Altitude	1NR
Calif. & Federal	¹ 2NR

¹ - 1NR for California models equipped with manual transmission.

FUEL PUMP

FUEL PUMP PRESSURE

Pinch off fuel return line (if equipped). Connect pressure gauge to fuel line at carburetor, and hold pressure gauge at level of fuel pump outlet. The 1979 Monza uses an electric fuel pump.

FUEL PUMP SPECIFICATIONS

Application	Specifications
1979	
Pressure	
Monza (At 12.6 volts)	4.25-6 psi
All Others (At Idle)	4.25-5.75 psi
Volume	
All Models (At Idle)	One pint in 30 seconds.

IGNITION

All models are equipped with High Energy Ignition (HEI) system. No adjustment is required.

NOTE: Module must be replaced as a unit. A liberal coat of silicone grease MUST be applied to surface on which module will be mounted.

IGNITION COIL

IGNITION COIL SPECIFICATIONS

Application	Specifications
Resistance	
Primary (At 75°F)	¹ 0.4-0.5 ohm
Secondary (At 75°F)	6000-30,000 ohms
Coil Output	
At all engine speeds	² 2500-3500 volts
¹ - One ohm on 1975 models; 0-0.1 ohms on 1978-79 models.	
² - Replace if below 2500 volts.	

Other Data & Specifications - See Delco Ignition Systems in DISTRIBUTORS & IGNITION SYSTEMS section.

CARBURETION

CARBURETORS

Application	Model
1978	
196" & 231" 2-Bbl.	2GE
200" 2-Bbl.	2GC
1979	
196" & 200" 2-Bbl.	Rochester M2ME
231" 2-Bbl.	
VIN Code A	Rochester M2ME
VIN Code 2	Rochester E2ME

Other Data & Specifications - See Rochester Carburetors in FUEL SYSTEMS section.