

1975-79 TUNE-UP PROCEDURES

Cadillac V8

ENGINE IDENTIFICATION

VEHICLE IDENTIFICATION NUMBER

The fifth character of the Vehicle Identification Number (VIN), located on a plate attached to the left top of instrument panel and visible through windshield, is the engine code letter.

VIN CODES

Application	Code
1975	
500" V8	S
1976	
350" V8	R
500" V8	S
1977-79	
350" V8	B
350" V8 Diesel	N
425" V8	
Carbureted (4-Bbl.)	S
Fuel Injected	T

ENGINE IDENTIFICATION CODE

The engine identification code for all 350" engines is located at front left side of cylinder block, next to water pump. On 425" and 500" engines, code is located on cylinder block (behind intake manifold).

ENGINE CODES

Application	Code
1975	
500" V8	S
1976	
350" V8	R
500" V8	S
1977-78	
350" V8	B
350" V8 Diesel	N
425" V8	
Carbureted	S
Fuel Injected	T
1979	
350" V8	
VIN B	EA, EC, KA, KB
VIN N (Diesel)	C2, C3, C4, C5, C6
	E2, E3, E4, E5, E6, K2, K3, K4, K5, K6,
	QP, QQ, QS, QT, QU, QW, QX, QY, T2, T3,
	T6, UB, U3, VG, VN, VO, VP, VQ, V4, V6
425" V8	
VIN S	AT, AX, AD, BA
VIN T	AH, AJ, AZ, AB

TUNE-UP NOTES

NOTE: In order to comply with emission standards, specifications shown on engine compartment Emission Control Tune-Up Decal must be used in all instances.

NOTE: Diesel engines require no tune-up type servicing. The only adjustment applicable is Injection Pump Timing which will be covered in this article. For additional information, see General Motors Diesel Fuel Injection article in FUEL SYSTEMS section.

NOTE: The EPA High Altitude emission standards apply to vehicles sold in certain areas outside of California which have an elevation above 4000 feet.

NOTE: Before making a compression test or cranking engine using a remote starting switch, disconnect ignition switch "BATT" feed wire at distributor.

NOTE: Do not remove spark plug wires with engine running. High Energy Ignition (HEI) system secondary voltage is higher than standard ignition systems and may inflict harmful electrical shock.

NOTE: Damage to HEI electronic module may result if "TACH" terminal, in distributor cap connector, is directly grounded.

ENGINE COMPRESSION

Gasoline Engine - Test compression pressure with engine at normal operating temperature, all spark plugs removed and throttle and choke valves wide open.

NOTE: Prior to checking compression, be sure batteries are fully charged to avoid battery run-down. When turning engine over during test, 6 "puffs" per cylinder should be used to obtain reading.

Diesel Engine - 1) Remove air cleaner. Install air crossover screened cover (J-26996-1).

2) Disconnect electrical wire from fuel solenoid terminal of injection pump.

3) Disconnect glow plug wires. Remove all glow plugs.

4) Use compression tester (J-26999) to test individual cylinders.

NOTE: Compression should build up quickly and evenly to proper level while rotating engine past 6 compression strokes. If piston rings are worn or cracked, compression will read low on first stroke, will rise on each stroke thereafter, but will not reach normal level.

COMPRESSION SPECIFICATIONS

Application	Specifications
Compression Ratio	
350" V8	
Seville	8.5:1
All Others	8.0:1
350" V8 Diesel	22.5:1
425" V8	8.2:1
500" V8	8.5:1
Recommended Fuel	
Diesel	¹ Diesel 2-D
Gasoline	Unleaded (87 AKI Minimum)
Compression Pressure	
350" V8	100 psi (Minimum)
350" V8 Diesel	275 psi (Minimum)
425" V8	140-165 psi
500" V8	145-165 psi
Maximum Variation Between Cylinders	30%

¹ - Use 1-D for vehicles operated below 20°F.

VALVE CLEARANCE

Hydraulic Lifters - Zero lash.

VALVE ARRANGEMENT

350" V8

E-I-E-E-I-E-I-E (Front-to-rear, both banks).

350" V8 Diesel

I-E-I-E-E-I-E-I (Front-to-rear, both banks).

425" & 500" V8

I-E-I-E-I-E-I-E (Front-to-rear, left bank),

E-I-E-I-E-I-E-I (Front-to-rear, right bank).

1975-79 TUNE-UP PROCEDURES Cadillac V8 (Cont.)

SPARK PLUGS

SPARK PLUG TYPE

Application	AC NO.
1975-76	
Seville	R46SX
All Others	R45NSX
1977-79	
Eldorado & Seville	R47SX
All Others	R45NSX

SPARK PLUG INSTALLATION

Application	Gap	Torque
All Models	1.060"	25 ft. lbs.

¹ - .080" on 1976 Seville.

HIGH TENSION WIRE RESISTANCE

Carefully remove ends of wire from spark plug and distributor. Using an ohmmeter, check resistance while gently twisting wire. If resistance is not to specification, or fluctuates from infinity to any value, replace wire.

WIRE RESISTANCE

Wire Length	Ohms (Maximum)
1975-76	
0-15"	10,000
15-25"	15,000
25-35"	20,000
Over 35"	25,000
1977-79	
0-24"	30,000
24"+	50,000

DISTRIBUTOR

All gasoline models are equipped with High Energy Ignition (HEI) system. No adjustment is required. On distributors having a

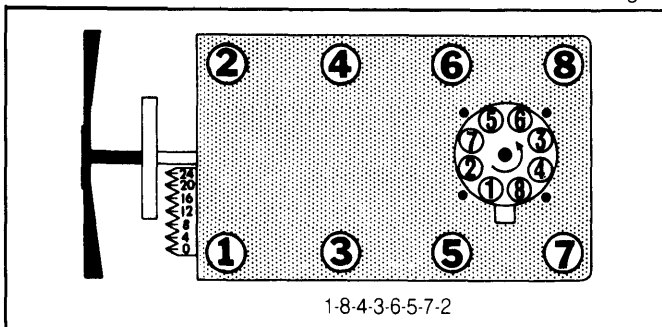

Fig. 1: 350" Firing Order & Timing Mark Identification

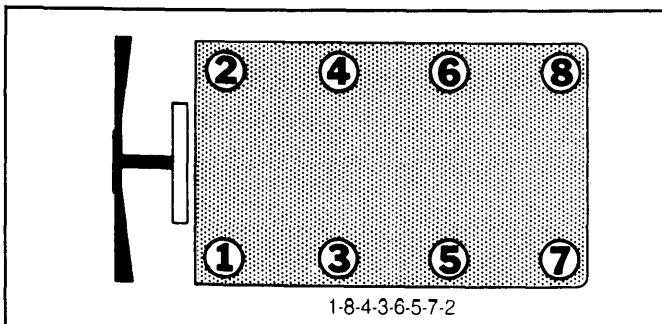

Fig. 2: 350" Diesel Firing Order

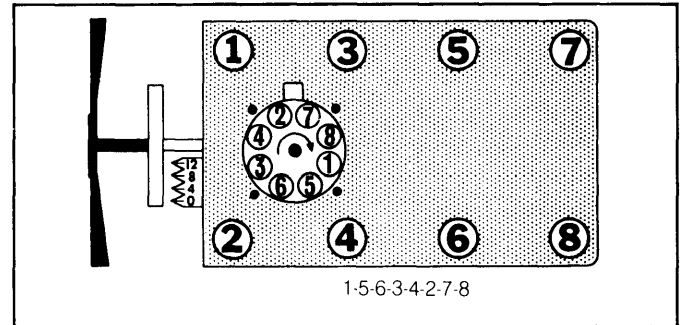

Fig. 3: 425" Firing Order & Timing Mark Identification (All Except 1978 Eldorado)

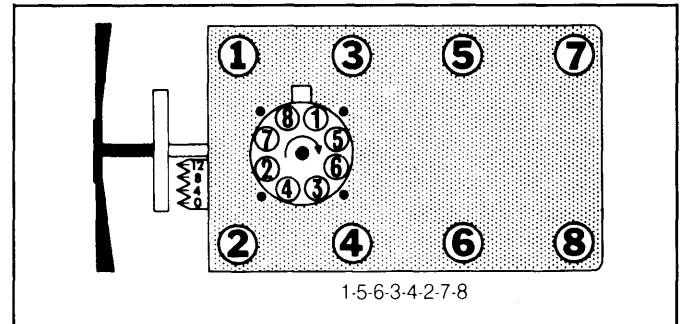

Fig. 4: 425" & 500" Firing Order & Timing Mark Identification (1978 Eldorado)

clockwise rotation, as viewed from above, the firing order is 1-5-6-3-4-2-7-8. On distributors having a counterclockwise rotation, the firing order is 1-8-4-3-6-5-7-2.

IGNITION TIMING

NOTE: Some engines may include a magnetic timing probe hole. This is for use with special electronic timing equipment. Refer to equipment manufacturer's instructions for correct procedures.

1975-76 Models - Disconnect and plug distributor vacuum advance hose and automatic level control hose (if equipped). Connect tachometer and timing light to engine. Set parking brake and place transmission in "P". Start and run engine at 600 RPM. Set timing to specification.

1977-78 Models - 1) Disconnect and plug distributor vacuum advance hose, EGR valve hose, and automatic level control hose (if equipped). Connect timing light or meter. Place transmission in "P" and start engine.

2) On carbureted models, place cam follower on second step of fast idle cam and adjust fast idle speed screw to obtain specified ignition timing RPM. Adjust timing to specified setting.

3) On fuel injected models, manually adjust throttle linkage to obtain specified ignition timing RPM. Adjust timing to specified setting. Recheck engine RPM and ignition timing.

1979 Models - Check or adjust ignition timing with engine at normal operating temperature, distributor and EGR vacuum lines disconnected and plugged, and engine at specified RPM.

1975-79 TUNE-UP PROCEDURES Cadillac V8 (Cont.)

IGNITION TIMING SPECIFICATIONS (DEGREES BTDC@RPM)

Application	Setting
1975	
Carbureted	6@600
Fuel Injected	12@600
1976	
Seville	10@600
All Others	
Carbureted	6@600
Fuel Injected	12@600
1977	
350" V8	
California	¹ 8@650
All Others	10@650
425" V8	18@1400
1978	
Carbureted	23@1600
Fuel Injected	
Brougham & DeVille	18@1400
Eldorado & Seville	10@600
1979	
Seville & Eldorado	10@600
All Others	
Carbureted	² 23@1600
Fuel Injected	18@1400

¹ - A production change starting with distributor No. 180291, revises ignition timing from 8°BTDC to 6°BTDC on California Seville models.

² - On models with Electronic Spark Selection (ESS) system, disconnect and plug fuel economy switch vacuum line.

INJECTION PUMP TIMING

Diesel Engine Only - Engine is properly timed when marks on top of injection pump adapter and pump flange are aligned. If marks are not aligned, adjustment is necessary. Engine must be off.

- 1) Loosen 3 pump retaining nuts with wrench (J-26987).
- 2) Align mark on pump with mark on adapter and tighten nuts. If necessary, use a 3/4" wrench on boss at front of injection pump to aid in rotating pump to align marks. Torque to 35 ft. lbs.
- 3) Adjust throttle rod. See LINKAGE ADJUSTMENT in see General Motors Diesel Fuel Injection article in FUEL SYSTEMS section.

HOT (SLOW) IDLE RPM

NOTE: Idle mixture and ignition timing adjustments must be correct before idle speed adjustment can be made.

CARBURETED ENGINES

1975-78 Models - Disconnect and plug parking brake vacuum hose at release cylinder and automatic level control vacuum hose at air cleaner (if equipped). With engine at normal operating temperature, set parking brake and block drive wheels. Place transmission in Drive and turn air conditioning off. Adjust carburetor idle screw to obtain specified idle RPM.

1979 Models - 1) Disconnect and plug parking brake hose at vacuum release cylinder. Set parking brake and block drive wheels. Disconnect and plug air leveling compressor hose at air cleaner.

- 2) With engine at normal operating temperature, place transmission in Drive, and turn air conditioning off.
- 3) Turn idle speed screw on throttle lever side of carburetor to obtain specified curb idle RPM.
- 4) Reconnect all disconnected hoses. Disconnect A/C compressor wires at compressor and turn A/C to "AUTO" position.
- 5) Open throttle slightly to allow solenoid plunger to fully extend. Adjust solenoid to obtain specified solenoid energized RPM.
- 6) After adjustment is completed, reconnect A/C compressor wires.

DIESEL ENGINES

NOTE: Use magnetic pickup tachometer (J-26925) to check idle speed. Insert probe in timing indicator hole.

- 1) Disconnect and plug parking brake hose at vacuum release cylinder. Set parking brakes and block drive wheels.
- 2) With engine at normal operating temperature, place transmission in Drive, and turn air conditioning off.
- 3) Adjust slow idle screw on injection pump to obtain specified idle speed RPM. See Fig. 5.
- 4) After adjustment is completed, reconnect all disconnected hoses.

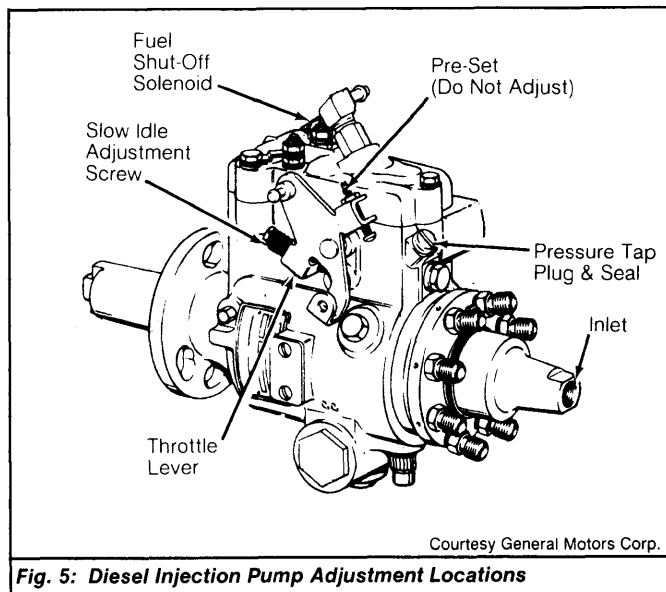

Fig. 5: Diesel Injection Pump Adjustment Locations

FUEL INJECTED ENGINES

- 1) Disconnect and plug distributor vacuum advance hose(s), and parking brake hose at vacuum release cylinder. Set parking brake and block drive wheels.
- 2) With engine at normal operating temperature, place transmission in Drive, and turn air conditioning off.
- 3) Loosen lock nut on idle by-pass adjusting screw on front of throttle body. Adjust by-pass screw to obtain specified curb idle RPM.
- 4) After adjustment is completed, tighten idle by-pass screw lock nut and reconnect all disconnected hoses.

IDLE SPEED (RPM) SPECIFICATIONS

Application	Curb Idle	Solenoid Energized
1975-76		
All Models	600	
1977		
Carbureted	600	
Fuel Injected	650	
1978		
Carbureted		
California	¹ 600	
Federal	550	
Fuel Injected	675	
1979		
350" V8		
Diesel	575	
Fuel Injected	600	
425" V8		
Carbureted	550	650
Fuel Injected	650	

¹ - 550 RPM on models equipped with carburetor No. 17058532.

1975-79 TUNE-UP PROCEDURES Cadillac V8 (Cont.)

IDLE MIXTURE

NOTE: The idle mixture adjustment procedure is for carbureted models only. Fuel injection air/fuel mixture is programmed into the system and cannot be adjusted.

MIXTURE SCREW PLUG REMOVAL

Idle mixture screws on all 1979 Rochester carburetors are covered by hardened steel plugs. Manufacturer recommends plug removal and mixture adjustment only after major carburetor overhaul, throttle body replacement or emissions failure. If plugs must be removed, proceed as follows:

- 1) Remove carburetor from engine, invert carburetor and drain fuel. Place inverted carburetor on holding fixture with manifold side up.
- 2) Using a punch between the 2 locator points under throttle body (manifold side), break through throttle body and drive out hardened steel plug covering mixture needle.

NOTE: Plug may shatter. Remove loose pieces.

- 3) Repeat procedure to remove remaining mixture screw plug. Reinstall carburetor on engine. Use a thin wall $\frac{3}{16}$ " deep socket to make mixture adjustments.

TACHOMETER (LEAN DROP) PROCEDURE

1975-77 Carbureted Engines - 1) Disconnect and plug distributor vacuum advance hose(s), parking brake release hose, and automatic level control vacuum hose (if equipped) at air cleaner. Remove air cleaner but keep vacuum hoses connected.

2) Turn mixture screws out 2 turns (5 turns on 1975-76 models) from seated position, so engine will just run. With engine at normal operating temperature and A/C off, place transmission in Drive.

3) Using an accurate tachometer to observe RPM readings, back out idle mixture screws $\frac{1}{8}$ turn at a time until maximum RPM reading is obtained. Now turn each screw in (lean) in $\frac{1}{8}$ turn increments until lower specified RPM reading is obtained. Reconnect hoses, install air cleaner and recheck idle speed.

IDLE MIXTURE RPM SPECIFICATIONS

Application	RPM
1975-76	
California	620/600
Federal	650/600
1977	
California	630/600
Federal	670/600

PROPANE ENRICHMENT PROCEDURE

1978-79 Carbureted Engines - 1) With engine at normal operating temperature, choke fully open and air conditioning off (if equipped), set parking brake and block drive wheels. Disconnect and plug hose at parking brake vacuum release cylinder. Disconnect and plug hoses as directed on Emission Control Tune-Up Label under hood.

2) Connect tachometer to engine. Disconnect vacuum advance and set timing to specification. Reconnect vacuum advance. Disconnect PCV ventilation tube from air cleaner. Insert hose with rubber stopper (J-26911) from propane valve into PCV ventilation tube opening in air cleaner.

3) Propane cartridge must be in a vertical position. Slowly open propane control valve until maximum engine speed is reached with transmission in Drive.

NOTE: Too much propane will cause engine speed to drop.

- 4) Observe propane flow meter; to ensure propane cartridge is full. With propane flowing, adjust idle speed screw to the enriched RPM (see specifications). Readjust propane flow to be certain of maximum engine speed and adjust idle speed if necessary.

5) Turn off propane. Place transmission in Neutral and run engine at 2000 RPM for 30 seconds. Place transmission in "D". Check idle speed. If it is as shown on Emission Information Label, idle mixture is correct. Proceed to step 8).

6) If idle speed is too low, back out mixture screws equally (richer) $\frac{1}{8}$ turn at a time until specified speed is obtained. If speed is too high, turn in screws equally (leaner) $\frac{1}{8}$ turn at a time until specified speed is obtained.

NOTE: It may be necessary to remove air cleaner to reach idle mixture screws. Reinstall air cleaner to check idle speed.

7) Turn propane on again to check maximum engine idle speed. If speed is different from specification, readjust idle speed screw to enriched RPM with propane flowing. Turn off propane and accelerate engine to 2,000 RPM for 30 seconds and recheck idle speed. Idle speed should be to specification, if not repeat procedure starting with step 6).

8) If idle is unusually rough, turn mixture screws in until lightly seated. Back screws out equally to average previous position and rerun propane idle test starting with step 2). If idle is correct, turn engine off and remove propane set up. Connect positive crankcase ventilation and reconnect all other hoses.

PROPANE ENRICHED IDLE SPEED SPECIFICATIONS

Application	Curb Idle	Enriched RPM
1978 ¹		
California		
17058832	600	575
17058530	550 ²	635
17058533	600	640
17058535	600	635
Federal		
17058230	550 ²	585
17058530	600 ²	630
17058531	600	640
17058533	600	640
High Altitude		
17058232	600 ²	620
17058233	600	625
1979		
350" V8		595-605
425" V8 4-Bbl.		
California		585-595
Federal		615-625
High Altitude		605-615

¹ - Adjust idle mixture according to carburetor number on 1978 models.

² - 675 RPM on A/C or solenoid equipped models.

COLD (FAST) IDLE RPM

Carbureted Engines - 1) With ignition timing set, disconnect and plug distributor and EGR vacuum hoses, and automatic level control vacuum hose (if equipped).

2) On 1975-76 models, open throttle and place cam follower on highest step of fast idle cam. Back out fast idle screw until it pulls away from cam follower. Turn fast idle screw until it just contacts cam follower. Turn fast idle screw in an additional $2 \frac{1}{4}$ turns (2 turns of Federal models).

3) On 1977-79 models, open throttle and place cam follower on second step of fast idle cam. Turn fast idle speed adjusting screw to obtain specified fast idle RPM. Reconnect all disconnected hoses.

1975-79 TUNE-UP PROCEDURES

Cadillac V8 (Cont.)

FAST IDLE SPEED (RPM) SPECIFICATIONS

Application	RPM
1975-76	
All Models	1200-1250
1977-78	
California & High Altitude	1500
Federal	1400
1979	
Brougham & Deville	
Federal	1000
California & High Altitude	1500
All Other Models	1500

FAST IDLE SOLENOID

Diesel Engine Only - 1) Disconnect and plug parking brake hose at vacuum release cylinder. Set parking brake and block drive wheels. Disconnect A/C compressor wires.

2) Place transmission in Drive and turn air conditioning on. Adjust fast idle solenoid plunger to obtain an engine speed of 650 RPM.

3) After adjustment is completed, reconnect A/C compressor wires and all disconnected hoses.

AUTOMATIC CHOKE

1976-78 Carbureted Engine - Place fast idle cam follower on highest step of cam and align index point on cover to specification.

1979 Carbureted Engine - Loosen choke cover retaining screws. Position cam follower on highest step of fast idle cam. Rotate cover and coil assembly counterclockwise until choke valve just closes. Align index mark on cover with specified setting on choke housing. Tighten cover screws.

AUTOMATIC CHOKE SETTING

Application	Setting
1975-79	
1975 California Models	1 NR
All Other Models	2 NR

FUEL PUMP

FUEL PUMP PRESSURE

Diesel Engine - 1) Remove air crossover. Install screened covers (J-26996-2). Remove fuel return pressure tap plug. See Fig. 5.

2) Screw pressure tap adapter (J-28526) into pump housing. Be sure to use seal from tap plug on tap adapter before installing. Connect a low pressure gauge to adapter.

3) Connect magnetic pickup tachometer (J-26925). Start engine and check pressure with engine at 1000 RPM. Pressure should be 8-12 psi with not more than 2 psi fluctuation.

4) If pressure is incorrect, replace fuel return line connector assembly and if still incorrect, remove injection pump and repair.

FUEL PUMP SPECIFICATIONS

Application	Specification
Carbureted	
Pressure (At 1800 RPM)	5.25-6.5 psi
Volume (At Idle)	1 pint in 30 sec.
Diesel	
Pressure	8-12 psi
Fuel Injected	
Pressure	
With Vacuum Hose Connected	39 psi
With Vacuum Hose Disconnected	46 psi
Relief Valve Opening Pressure	55-95 psi
Delivery Rate	33 gallons per hr.

5) Remove tachometer, pressure gauge and adapter. Put a new pressure tap plug seal on pressure tap plug, then screw in tap plug. Remove screened covers and install air crossover.

INJECTION NOZZLES

Diesel Engine - 1) If engine starts, but idles roughly, check injection nozzles as follows: Start and idle engine. Loosen line fitting at each nozzle, one at a time. Be sure to direct fuel away from ignition sparks.

2) If, when nozzle fitting is loosened, idle speed or quality does not change, replace that nozzle and repeat test.

3) Disconnect fuel return system from nozzles on one bank of engine at a time. Start engine. Observe fuel seepage at nozzles. Replace any nozzle that leaks excessively. Tighten nozzle clamp bolt to 25 ft. lbs.

IGNITION

DISTRIBUTOR

Delco High Energy Ignition - Electronic Spark Selection System (ESS) has been added to some 1978-79 models. This provides electronic spark advance or retard as conditions warrant and improves highway fuel economy.

NOTE: Module must be replaced as a unit. A liberal coat of silicone grease MUST be applied to surface on which module will be mounted.

Other Data & Specifications - See Delco Ignition Systems article in DISTRIBUTORS & IGNITION SYSTEMS section.

IGNITION COIL

IGNITION COIL SPECIFICATIONS

Application	Specification
Resistance	
Primary (at 80°F)	0.4-0.5 ohm
Secondary (at 80°F)	8000-9500 ohms
Coil Output	¹ 25,000-35,000 volts

¹ - Replace if below 25,000 volts.

FUEL SYSTEMS

CARBURETOR

CARBURETOR

Application	Model
1975	
500" V8	Rochester M4MEA 4-Bbl.
425" & 500" V8	
High Altitude	Rochester M4MEA 4-Bbl.
All Others	Rochester M4ME 4-Bbl.
1976	
500" V8	
High Altitude	Rochester M4MEA 4-Bbl.
All Others	Rochester M4ME 4-Bbl.
1977	
425" V8	
High Altitude	Rochester M4MEA 4-Bbl.
All Others	Rochester M4ME 4-Bbl.
1978-79	
425" V8	Rochester M4ME 4-Bbl.

Other Data & Specifications - See Rochester Carburetor article in FUEL SYSTEMS section.

1975-79 TUNE-UP PROCEDURES

Cadillac V8 (Cont.)

1-27

FUEL INJECTION

Electronic Fuel Injection precisely controls the air/fuel mixture for combustion by electronically metering, through injectors, the amount of fuel sprayed into the engine. A closed loop EFI system is used on Seville models sold in California.

Throttle Position Switch (TPS) Adjustment - 1) Loosen switch mounting screws and hold throttle blades in idle position. Carefully rotate switch in a counterclockwise direction until end stop is reached. Tighten mounting screws to 11 INCH lbs. and check that blades close to throttle stop.

3) Turn ignition switch on and rotate throttle lever until first "click" is heard. Insert a .020" feeler gauge between throttle lever and idle stop screw.

4) Clearance must be .020" or less. If adjustment is required, turn TPS clockwise and repeat adjustment procedure until clearance is correct. If correct clearance cannot be obtained, replace throttle position switch.

Other Data & Specifications - See General Motors Electronic Fuel Injection article in FUEL SYSTEMS section.

FUEL INJECTOR DELIVERY SEQUENCE

First Group - Cylinders 1 & 2 and 7 & 8.

Second Group - Cylinders 3 & 4 and 5 & 6.

All injectors in each group are open simultaneously and each group is opened alternately.

DIESEL FUEL INJECTION

A mechanical, gear driven fuel pump is used.

Other Data & Specifications - See General Motors Diesel Fuel Injection article in FUEL SYSTEMS section.