

# Rochester Carburetors

## ROCHESTER MODELS 2G, 2GC & 2GV 2-BARREL

### MODEL 2G CHEVROLET

Application	Rochester No.
1965	
283" V8 .....	7023010
283" V8 With Governor .....	7023009
1966	
283" V8 .....	7023010
283" V8 With Overdrive .....	7023022
283" V8 With Governor .....	7023009
283" V8 Man. Trans. With A.I.R. ....	7036105
283" V8 Auto. Trans. With A.I.R. ....	7036100

### CHEVROLET & GMC

Application	Rochester No.
1967	
283" V8 .....	7027105, 7020109
283" V8 With Overdrive .....	7027100
283" V8 With Governor .....	7027106
283" V8 With A.I.R. ....	7037105
283" V8 With Overdrive & A.I.R. ....	7037100
1968	
307" V8 10 & 1500 Series (Early).....	7028105
307" V8 10 & 1500 Series With Gov. (Early) .....	7028106
307" V8 10 & 1500 Series With O.D. (Early) .....	7028100
307" V8 10 & 1500 Series (Late).....	7028125
307" V8 20 & 2500 Series (Early).....	7028107
307" V8 20 & 2500 Series With Gov. (Early) .....	7028111
307" V8 & 20 & 2500 Series (Late).....	7028127
1969	
307" V8 G-10 & 1500 .....	7029125
307" V8 With Governor .....	7029108
307" V8 All Others.....	7029107
350" V8 .....	7029123

### JEEP

Application	Rochester No.
1965	
225" V6 .....	7026802
1966	
225" V6 .....	7026082
225" V6 With A.I.R. ....	7027082
1967	
225" V6 .....	7026082
225" V6 With A.I.R. ....	7027082
1968	
225" V6 .....	7026082
225" V6 With A.I.R. ....	7027082
1969	
225" V6 .....	7026082
225" V6 With A.I.R. ....	7027082
1970	
225" V6 .....	7026082
225" V6 With A.I.R. ....	7027082
1971	
225" V6 .....	7041185

### MODEL 2GC JEEP

Application	Rochester No.
1965	
225" V6 .....	7026089
1966	
225" V6 .....	7026089
225" V6 With A.I.R. ....	7027089
1967	
225" V6 .....	7026089
225" V6 With A.I.R. ....	7027089
1968	
225" V6 .....	7026089
225" V6 With A.I.R. ....	7027089
1969	
225" V6 .....	7026089
225" V6 With A.I.R. ....	7027089
1970	
225" V6 .....	7026089
225" V6 With A.I.R. ....	7027089
1971	
225" V6 .....	7041186

### MODEL 2GV

#### CHEVROLET & GMC

Application	Rochester No.
1969	
307" V8 .....	7029105
350" V8 .....	7029121
1970	
307" V8 10 & 1500 Series Man. Trans. ....	7040105
307" V8 10 & 1500 Series Man. Trans.⓪ .....	7040405
307" V8 10 & 1500 Series Auto. Trans. ....	7040125
307" V8 10 & 1500 Series Auto. Trans.⓪ .....	7040425
307" V8 20, 2500, 30 & 3500 Series .....	7040108
1971	
307" V8 G-10 & 1500 Man. Trans. ....	7041111
307" V8 G-10 & 1500 Auto. Trans. ....	7041126
307" V8 C, K & P-10 & 1500 Man. Trans. ....	7041105
307" V8 C, K & P-10 & 1500 Auto. Trans. ....	7041125
307" V8 20, 2500, 30 & 3500 Series Man. Trans. ....	7041139
307" V8 20, 2500, 30 & 3500 Series Auto. Trans. ....	7041138
1972	
307" V8 G-10 & 1500 (Federal) Man. Trans. ....	7042103
307" V8 G-10 & 1500 (Federal) Auto. Trans. ....	7042102
307" V8 G-10 & 1500 (Calif.) Man. Trans. ....	7042823
307" V8 G-10 & 1500 (Calif.) Auto. Trans. ....	7042822
307" V8 C & K-10 & 1500 (Federal) Man. Trans. ....	7042105
307" V8 C & K-10 & 1500 (Federal) Auto. Trans. ....	7042104
307" V8 C & K-10 & 1500 (Calif.) Man. Trans. ....	7042825
307" V8 C & K-10 & 1500 (Calif.) Auto. Trans. ....	7042824
307" V8 20, 2500, 30 & 3500 Series .....	7042108

## ROCHESTER MODELS 2G, 2GC & 2GV 2-BARREL (Cont.)

1973		
307" V8 G-10 & 1500	.....	7043103
307" V8 C & K-10 & 1500	.....	7043105
307" V8 20, 2500, 30 & 3500 Series	.....	7043108
1974		
350" V8 G-10 & 1500 Man. Trans.	.....	7044123
350" V8 G-10 & 1500 Auto. Trans.	.....	7044124
350" V8 C & K-10 & 1500 Man. Trans.	.....	7044113
350" V8 C & K-10 & 1500 Auto. Trans.	.....	7044114

Ⓞ — With Evaporative Emission System.

### JEEP

Application	Rochester No.
1969	
350" V8	.....7028088
1970	
350" V8	.....7040482, 7028088
1971	
350" V8	.....7041184

**NOTE** — Carburetors used on vehicle with A.I.R. or CCS are special units with different jet calibrations and adjustment specifications.

### CARBURETOR IDENTIFICATION

Rochester carburetor part number is stamped on a horizontal section of the float bowl, near the fuel inlet nut. When float bowl assembly is being replaced, manufacturers instructions, contained in service package, must be followed so that the part number is transferred to the new float bowl.

### DESCRIPTION

Carburetors are of 2-barrel downdraft design with side fuel bowl, 2GC models are equipped with an automatic integral choke. The automatic choke housing and thermostatic coil of the 2GC may be located on the air horn or throttle body, depending on application. The 2GV carburetor is also an automatic choke model, however, a vacuum break diaphragm unit is used in place of the conventional choke housing and piston.

### ADJUSTMENT

#### HOT (SLOW) IDLE RPM

See appropriate article in TUNE-UP Section.

#### COLD (FAST) IDLE RPM

See appropriate article in TUNE-UP Section.

#### ACCELERATOR LINKAGE

See appropriate article in TUNE-UP Section.

#### FLOAT LEVEL

**1965-70 Jeep 225" V6** — With air horn inverted and gasket in place, measure distance from top of float to air horn gasket (see illustration). Distance should be as indicated in specifications. To adjust, bend float arm at needle valve. Check float alignment.

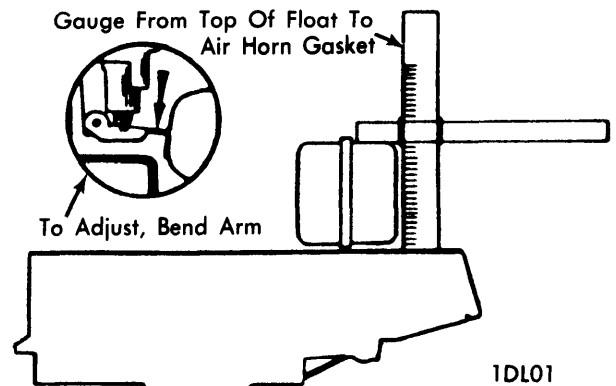

**FLOAT LEVEL ADJUSTMENT**  
(1965-70 JEEP 225" V6)

**1965-69 All Others & 1970 307" V8 (Heavy Duty)** — With air horn inverted and gasket in place, measure distance from toe of float at lower edge of seam and air horn gasket (see illustration). Distance should be as indicated in specifications. To adjust, bend float arm at needle valve. Check float alignment.

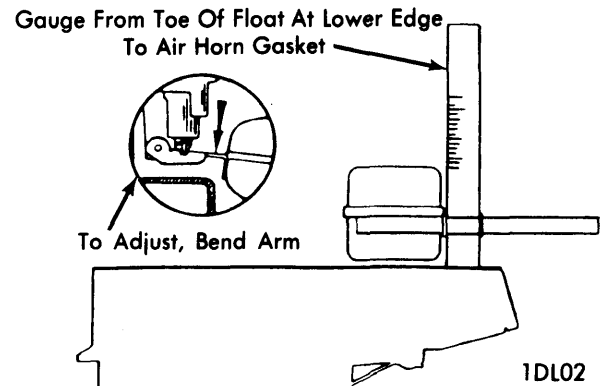

**FLOAT LEVEL ADJUSTMENT**  
(1965-69 All Others)

**1970-74 All Others** — With air horn inverted and gasket in place, measure distance from lip at toe of float to air horn gasket (see illustration). Distance should be as indicated in specifications. To adjust, bend float arm at needle valve. Check float alignment.

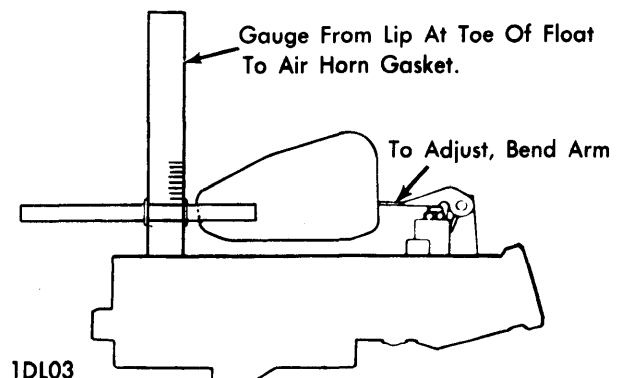

**FLOAT LEVEL ADJUSTMENT**  
(1970-74 All Others)

# Rochester Carburetors

## ROCHESTER MODELS 2G, 2GC & 2GV 2-BARREL (Cont.)

### FLOAT DROP

**1965-69 Models & 1970 307" Heavy Duty** — Position air horn right side up and allow float to hang free. With gasket in place, measure distance between gasket surface and bottom of float. Distance should be as indicated in specifications. To adjust, bend float tang. Needle valve must not wedge to side when float is at maximum drop.

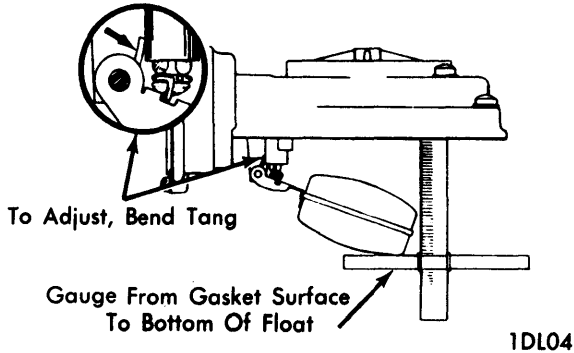

**FLOAT DROP ADJUSTMENT**  
(1965-69 All & 1970 307" Heavy Duty)

**1970-74 All Others** — Position air horn right side up and allow float to hang free. With gasket in place, measure distance between gasket surface and notch at toe of float. Distance should be as indicated in specifications. To adjust, bend float tang. Needle valve must not wedge to side when float is at maximum drop.

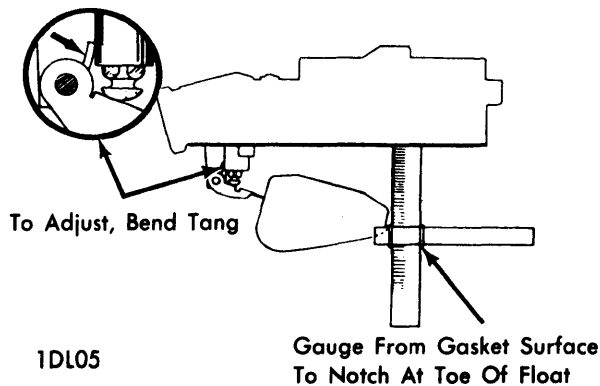

**FLOAT DROP ADJUSTMENT**  
(1970-74 All Others)

### ACCELERATOR PUMP ROD

Back out idle speed screw until throttle valves are completely closed. Measure distance from top of air horn ring to top of pump rod. Distance should be as indicated in specifications. To adjust, bend pump rod.

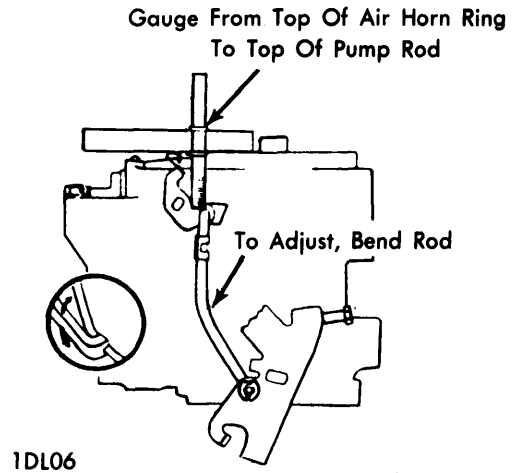

**PUMP ROD ADJUSTMENT**

### IDLE VENT

**All Models (If Equipped)** — Idle speed must be adjusted to specified RPM and idle speed solenoid energized if equipped. Choke valve must be fully open and fast idle tang off of fast idle cam. Insert specified gauge in vent opening and check clearance. Clearance should be as indicated in specifications. To adjust, bend tang.

Application	Idle Vent Clearance Specifications	Clearance
7028125, 7028127, 7029121	.....	.020"
7028088, 7040105, 7040108, 7040125	.....	.025"

### VACUUM BREAK

**All Models (With Automatic Choke)** — Seat vacuum diaphragm by attaching an outside vacuum source. Hold choke valve closed with choke rod in bottom of slot in choke lever. Check clearance between upper edge of choke valve and air horn wall using specified gauge. To adjust to specified clearance, bend rod.

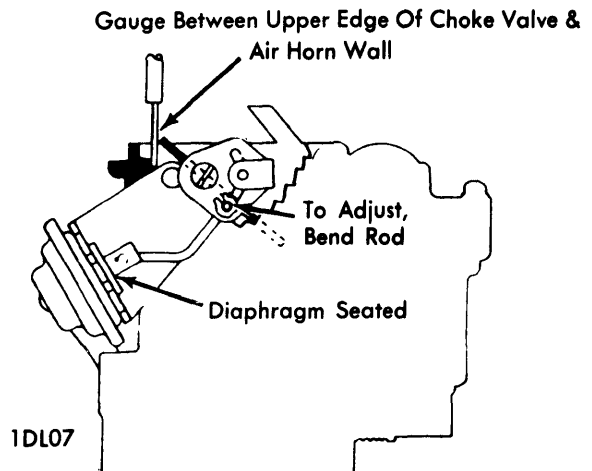

**VACUUM BREAK ADJUSTMENT**

## ROCHESTER MODELS 2G, 2GC & 2GV 2-BARREL (Cont.)

### AUXILIARY VACUUM BREAK

**1970-71 Jeep 350"** — If vehicle is equipped with a Fuel Evaporation System, remove vacuum break diaphragm hose and rubber cover on filter element from vacuum tube. Plug bleed hole with a piece of tape. Seat vacuum diaphragm with an outside vacuum source. Hold choke valve closed with choke rod in bottom of slot in choke lever. Check clearance between upper edge of choke valve and air horn wall using a specified gauge. To adjust to specified clearance, bend rod.

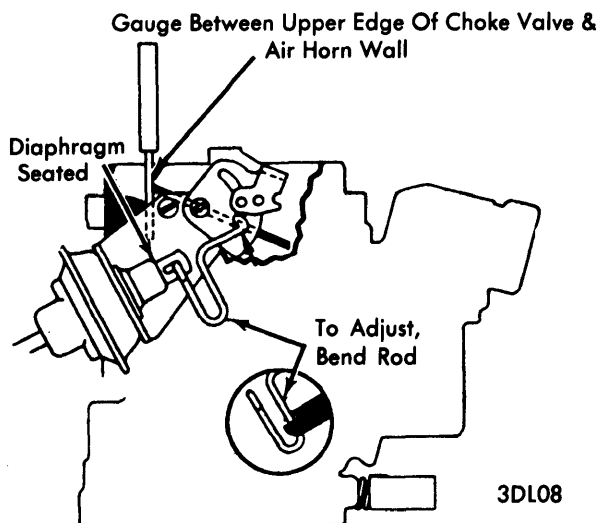

**AUXILIARY VACUUM BREAK ADJUSTMENT**

### CHOKE ROD (FAST IDLE CAM)

**All Models (With Automatic Choke)** — Position idle speed screw on second step of fast idle cam against shoulder of high step of cam. With choke valve closed, check clearance between upper edge of choke valve and air horn wall with a specified gauge. To adjust, bend tang on choke lever (see illustration).

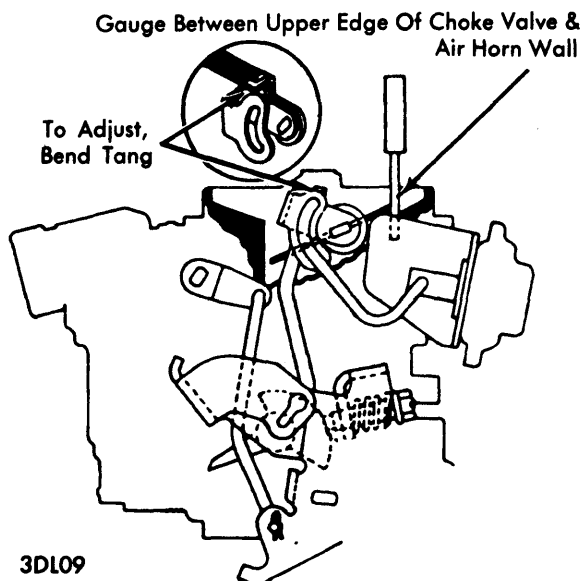

**CHOKE ROD (FAST IDLE CAM) ADJUSTMENT**

### UNLOADER

**All Models (With Automatic Choke)** — With throttle valves held wide open, check clearance between choke valve and air horn casting (see illustration) using a specified gauge. To adjust, bend tang.

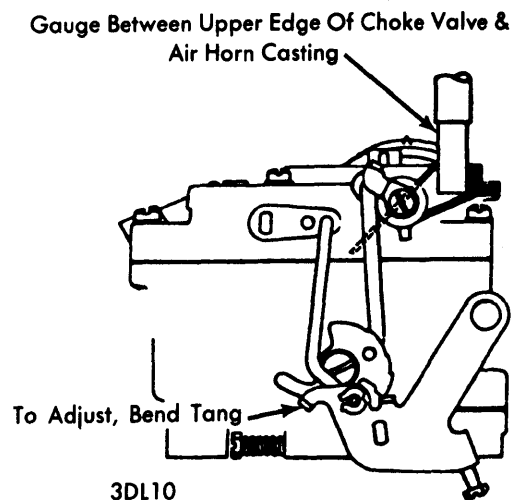

**UNLOADER ADJUSTMENT**

### AUTOMATIC CHOKE COIL

**All Vehicles With 2GC Carburetor** — Place idle screw on high step of fast idle cam and loosen three choke cover retaining screws. Rotate cover against tension of coil and line up index mark with specified point.

### CHOKE COIL ROD

**1969-70 2GV Carburetor** — Remove upper end of rod from choke lever and pull rod up to end of travel. With choke valve held completely closed, bottom of rod should be even with top of hole (Chevrolet and GMC) or end of rod should fit gauge notch (Jeep). To adjust, bend rod.

**1971-74 2GV Carburetor** — Remove upper end of rod from choke lever and push rod down to end of travel. With choke valve held wide open, rod should fit notch in lever (1971 models) or rod should fit in bottom of slot in lever (1972-74 models). To adjust, bend rod.

### MANUAL CHOKE

**All Vehicles With 2G Carburetor** — Push choke knob into stop, then pull out  $\frac{1}{8}$ ". Loosen cable clamp at carburetor bracket and adjust cable through clamp until choke valve is fully open and tighten clamp. Make sure choke valve fully opens and closes as cable is actuated.

### COMBINED EMISSION CONTROL (CEC) VALVE

**NOTE** — CEC Valve is preset at factory and normally should not require adjustment. However in the case of solenoid replacement, major carburetor overhaul or throttle body replacement, use following procedure to adjust CEC Valve.

With hot (slow) idle RPM correctly adjusted and engine off, pull outward on end of CEC valve plunger to end of travel. Adjust plunger to just contact throttle lever.

# Rochester Carburetors

## ROCHESTER MODELS 2G, 2GC & 2GV 2-BARREL (Cont.)

CARBURETOR ADJUSTMENT SPECIFICATIONS									
Rochester Carb. No.	Hot Idle Speed (Engine RPM) ①		Float Level Setting	Float Drop Setting	Pump Rod Setting	Choke Rod Setting	Vacuum Break Setting	Unloader Setting	Auto. Choke Setting
	Man. Trans.	Auto. Trans.							
7020109	.....	.....	3/4"	1 29/32"	1 1/8"	.....	.....	.....	.....
7023009	.....	.....	3/4"	1 29/32"	1 1/8"	.....	.....	.....	.....
7023010	.....	.....	3/4"	1 29/32"	1 1/8"	.....	.....	.....	.....
7023022	.....	.....	3/4"	1 29/32"	1 1/8"	.....	.....	.....	.....
7026082	.....	.....	1 5/32"	1 3/4"	1 5/32"	.....	.....	.....	.....
7026089	.....	.....	1 5/32"	1 3/4"	1 5/32"	.055"	.....	.140"	INDEX
7027082	.....	.....	1 5/32"	1 3/4"	1 5/32"	.055"	.....	.140"	INDEX
7027089	.....	.....	1 5/32"	1 3/4"	1 5/32"	.055"	.....	.140"	INDEX
7027100	.....	.....	3/4"	1 29/32"	1 1/8"	.....	.....	.....	.....
7027105	.....	.....	3/4"	1 29/32"	1 1/8"	.....	.....	.....	.....
7027106	.....	.....	3/4"	1 29/32"	1 1/8"	.....	.....	.....	.....
7028088	.....	.....	1 1/32"	1 3/4"	1 1/16"	.035"	.065"	.140"	.....
7028100	.....	.....	3/4"	1 3/4"	1 1/8"	.....	.....	.....	.....
7028105	.....	.....	3/4"	1 3/4"	1 1/8"	.....	.....	.....	.....
7028106	.....	.....	3/4"	1 3/4"	1 1/8"	.....	.....	.....	.....
7028107	.....	.....	3/4"	1 3/4"	1 1/8"	.....	.....	.....	.....
7028111	.....	.....	3/4"	1 3/4"	1 1/8"	.....	.....	.....	.....
7028125	.....	.....	3/4"	1 3/4"	1 5/32"	.....	.....	.....	.....
7028127	.....	.....	3/4"	1 3/4"	1 5/32"	.....	.....	.....	.....
7029105	.....	.....	2 7/32"	1 3/4"	1 1/8"	.095"	.130"	.215"	.....
7029107	.....	.....	2 7/32"	1 3/4"	1 1/8"	.....	.....	.....	.....
7029108	.....	.....	2 7/32"	1 3/4"	1 1/8"	.....	.....	.....	.....
7029121	.....	.....	1 9/32"	1 3/4"	1 3/8"	.120"	.260"	.375"	.....
7029123	.....	.....	3/4"	1 3/8"	1 1/16"	.....	.....	.....	.....
7029125	.....	.....	2 7/32"	1 3/4"	1 1/8"	.....	.....	.....	.....
7036100	.....	.....	3/4"	1 29/32"	1 1/8"	.....	.....	.....	.....
7036105	.....	.....	3/4"	1 29/32"	1 1/8"	.....	.....	.....	.....
7037100	.....	.....	3/4"	1 29/32"	1 1/8"	.....	.....	.....	.....
7037105	.....	.....	3/4"	1 29/32"	1 1/8"	.....	.....	.....	.....
7040105	.....	.....	2 1/32"	1 3/8"	1 3/8"	.060"	.140"	.215"	.....
7040108	.....	.....	2 7/32"	1 3/4"	1 3/8"	.095"	.130"	.215"	.....
7040125	.....	.....	2 1/32"	1 3/8"	1 3/4"	.060"	.140"	.215"	.....
7040405	.....	.....	2 1/32"	1 3/8"	1 5/16"	.060"	.140"	.215"	.....
7040425	.....	.....	2 1/32"	1 3/8"	1 5/16"	.060"	.140"	.215"	.....
7040482	.....	.....	1 3/16"	1 3/4"	1 13/32"	.080"	.150"②	.180"	.....
7041105	.....	.....	2 1/32"	1 3/8"	1 3/8"	.075"	.110"	.215"	.....
7041111	.....	.....	2 1/32"	1 3/8"	1 3/8"	.075"	.110"	.200"	.....
7041125	.....	.....	2 1/32"	1 3/8"	1 3/8"	.040"	.080"	.215"	.....
7041126	.....	.....	2 1/32"	1 3/8"	1 3/8"	.040"	.080"	.215"	.....
7041138	.....	.....	2 5/32"	1 1/8"	1 11/32"	.085"	.200"	.325"	.....
7041139	.....	.....	2 5/32"	1 1/8"	1 17/32"	.085"	.215"	.275"	.....
7041184	.....	.....	1 3/16"	1 13/16"	1 3/8"	.080"	.150"②	.180"	.....
7041185	.....	.....	1 5/32"	1 7/8"	1 1/16"	.....	.....	.....	.....
7041186	.....	.....	1 5/32"	1 7/8"	1 1/16"	.055"	.....	.140"	INDEX
7042102	.....	.....	2 1/32"	1 9/32"	1 5/16"	.040"	.080"	.210"	.....
7042103	.....	.....	2 1/32"	1 9/32"	1 5/16"	.075"	.110"	.210"	.....
7042104	.....	.....	2 1/32"	1 9/32"	1 5/16"	.040"	.080"	.210"	.....
7052105	.....	.....	2 1/32"	1 9/32"	1 5/16"	.075"	.110"	.210"	.....
7042108	.....	.....	2 5/32"	1 9/32"	1 1/2"	.100"	.170"	.325"	.....
7041822	.....	.....	2 1/32"	1 9/32"	1 5/16"	.040"	.080"	.210"	.....
7042823	.....	.....	2 1/32"	1 9/32"	1 5/16"	.075"	.110"	.210"	.....
7042824	.....	.....	2 1/32"	1 9/32"	1 5/16"	.040"	.080"	.210"	.....
7042825	.....	.....	2 1/32"	1 9/32"	1 5/16"	.040"	.110"	.210"	.....
7043103	.....	.....	1 3/16"	1 9/32"	1 3/8"	.150"	.080"	.215"	.....
7043105	.....	.....	1 3/16"	1 9/32"	1 3/8"	.150"	.080"	.215"	.....
7043108	.....	.....	2 5/32"	1 9/32"	1 7/16"	.245"	.170"	.350"	.....

## ROCHESTER MODELS 2G, 2GC & 2GV 2-BARREL (Cont.)

CARBURETOR ADJUSTMENT SPECIFICATIONS (Cont.)									
Rochester Carb. No.	Hot Idle Speed (Engine RPM) ①		Float Level Setting	Float Drop Setting	Pump Rod Setting	Choke Rod Setting	Vacuum Break Setting	Unloader Setting	Auto. Choke Setting
	Man. Trans.	Auto. Trans.							
7044113	.....	.....	1 $\frac{9}{32}$ "	1 $\frac{9}{32}$ "	1 $\frac{21}{32}$ "	.200"	.140"	.250"	.....
7044114	.....	.....	1 $\frac{9}{32}$ "	1 $\frac{9}{32}$ "	1 $\frac{1}{16}$ "	.245"	.130"	.325"	.....
7044123	.....	.....	1 $\frac{9}{32}$ "	1 $\frac{9}{32}$ "	1 $\frac{21}{32}$ "	.200"	.140"	.250"	.....
7044124	.....	.....	1 $\frac{9}{32}$ "	1 $\frac{9}{32}$ "	1 $\frac{1}{16}$ "	.245"	.130"	.325"	.....

① — See appropriate article in TUNE-UP Section.

② — Auxiliary vacuum break is .140".

## OVERHAUL

### DISASSEMBLY

**Air Horn** — Remove fuel inlet fitting, gasket and screen. Remove retaining screw, and vent valve and shield. Remove pump rod and choke intermediate rod, then remove choke trip lever and fast idle link and lever. **CAUTION** — *If fast idle link retained by Truarc washer, do not disconnect link from cam.* Remove attaching screws, separate air horn from main body, then remove float and needle valve assembly. Disconnect intake needle valve from float. Remove intake needle seat and gasket, and remove filter from needle seat bore. Remove power piston by depressing stem and allowing it to snap free (or hold stem and tap lightly on air horn). Remove pump plunger assembly from pump arm, then loosen setscrew on pump inner arm and remove pump outer lever and shaft. On all carburetors, take out screw in end of choke shaft and disengage vacuum break lever from shaft (allow lever to hang on diaphragm rod), take out diaphragm mounting screws and remove vacuum break diaphragm assembly. If necessary to replace choke valve or shaft, remove choke valve screws, lift valve out, slide choke shaft from air horn.

**Main Body (Float Bowl)** — Remove pump return spring from pump cylinder, remove pump inlet filter screen and inlet check ball (if used). On carburetors with idle compensator valve, take out attaching screws and remove idle compensator and gasket. Remove main metering jets and power valve. Take out venturi cluster retaining screws and lift out venturi cluster, gasket, and separate main well inserts (if used). **CAUTION** — *Do not attempt to disassemble cluster.* Use needle nose pliers to lift out pump discharge spring guide, remove spring and pump discharge check ball. Invert float bowl assembly, remove three throttle body attaching screws, lift off throttle body and gasket.

**Throttle Body** — On carburetors with automatic choke mounted on throttle body, see Automatic Choke data for disassembly of automatic choke. On all models, remove fast idle retaining screw and remove fast idle cam and link assembly. Remove idle mixture adjusting screws and springs. Do not disassemble throttle body further. *Throttle body is serviced as an assembly with throttle valves and shaft.*

### CLEANING & INSPECTION

Clean all carburetor castings and metal parts in cleaning solvent. Do not immerse choke housing and coil assembly, pump plunger, or vacuum break diaphragm in cleaning solvent. Clean pump plunger in clean gasoline, clean vacuum break diaphragm by wiping with clean cloth. Blow out all passages with compressed air. Inspect all parts for wear or damage and replace as necessary.

### ASSEMBLY

Use all new gaskets. Reassemble carburetor by reversing disassembly procedure and note the following:

**Choke Valve Installation** — Install valve with identifying mark "RP" upward, center choke valve before tightening screws. **NOTE** — *Valve can be centered by installing fast idle lever and choke trip lever on end of shaft and maintaining .020" clearance between fast idle lever and air horn casting, or between choke trip lever and choke lever and collar assembly.* Stake choke valve screws lightly after tightening. Choke valve should move freely in housing.

**Accelerating Pump Assembly** — Lubricate pump shaft with Lubriplate or light grease when installing in bowl cover. Make certain that pump check balls are not interchanged. Inlet check ball is aluminum, discharge check ball is steel. **NOTE** — *No inlet check ball is used in Chevrolet 2GV carburetors (fuel inlet is through 2-piece pump plunger assembly).*

**Automatic Choke (Type mounted on Throttle Body)** — Take out three choke cover attaching screws and retainers, remove choke cover and thermostatic coil assembly, cover gasket, and baffle plate. Remove two choke housing attaching screws, remove choke housing from throttle body, remove and discard housing gasket. Remove choke lever and shaft from choke housing. Remove dust seal from choke housing.

# Rochester Carburetors

## ROCHESTER MODELS 2G, 2GC & 2GV 2-BARREL (Cont.)

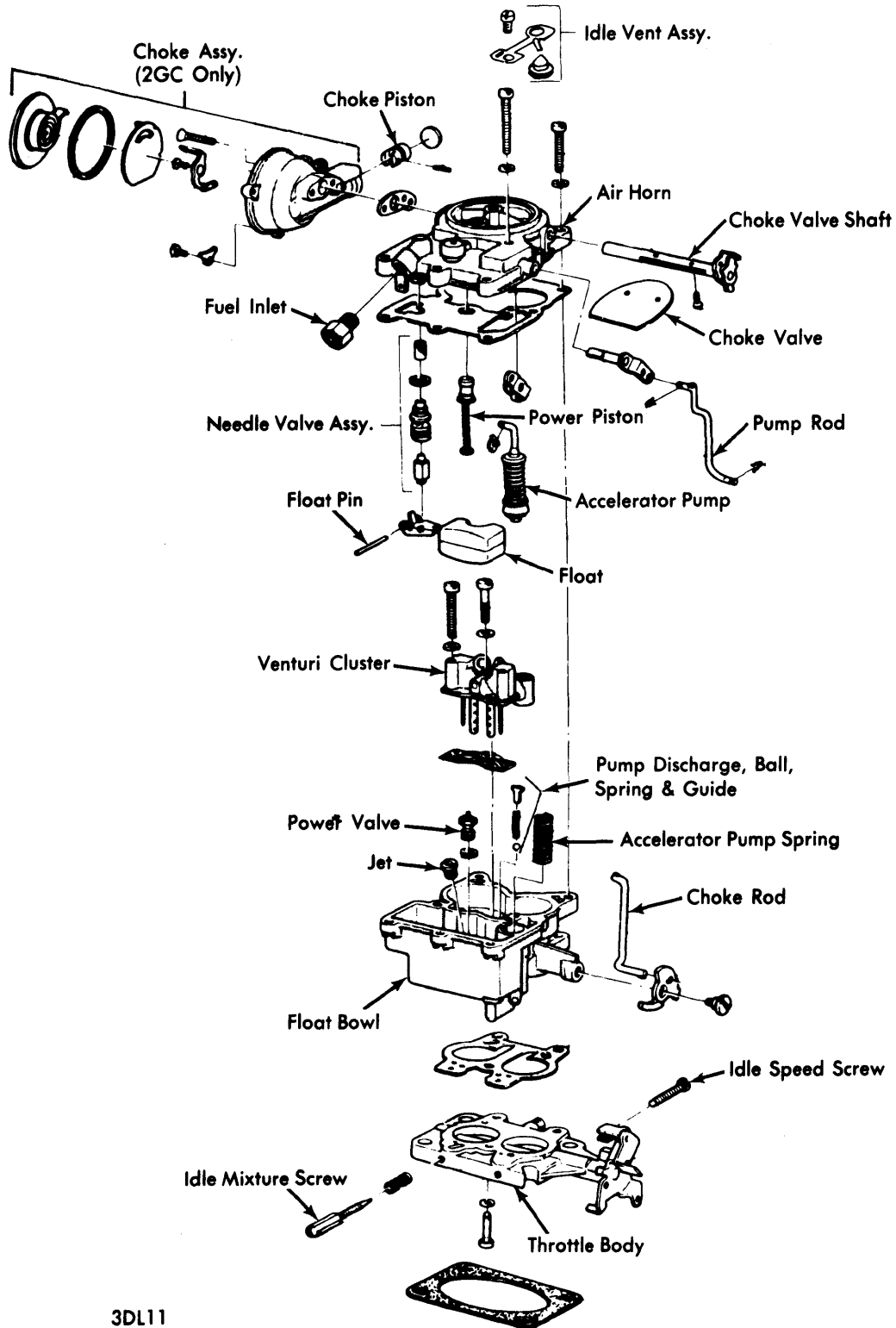

3DL11

**ROCHESTER 2-BARREL CARBURETOR  
(TYPICAL, 2GC SHOWN)**