

TUNE-UP

ENGINE IDENTIFICATION

Engine code letter is fourth digit of Official Serial Number or Warranty Number.

Application	Code
170" 6 Cyl.....	F
240" 6-Cyl.....	A
300" 6-Cyl.....	B

MODEL IDENTIFICATION

RATING PLATE

F100/350 & E100 - Rating Plate is located on rear (lock) fact of left front door.

U100 - Rating Plate is located on inner panel of glove box door.

Cowl & Windshield Models - Rating Plate is mounted on right side of cowl top panel or upper cowl panel under hood.

P35TUA27000

- First Digit - Truck Series Letter.
- Second & Third Digits - Truck Series Numbers.
- Fourth Digit - Engine Code.
- Fifth Digit - Assembly Plant.
- Remaining Digits - Consecutive Unit Number.

TUNE-UP NOTES

► **IDLE SPEED ADJUSTMENT CAUTION** - Procedures and specifications for idle speed adjustment must be followed exactly as outlined. See "Hot (Slow) Idle RPM" under Tune-Up.

NOTE - For other items affecting Tune-Up, see CARBURETION Section or EMISSION CONTROL Section.

COMPRESSION PRESSURE

Check compression with throttle wide open at cranking speed. Compression pressure should be at least 75% of highest reading.

VALVE TAPPET CLEARANCE

Application	Mechanical	Hydraulic
170"018"	
240" & 300"		① .082-.152"

① - One turn down after contact. Clearance is with tappet collapsed.

VALVE ARRANGEMENT

- 170" - E-I-I-E-I-E-E-I-E-I-E-I-E-I-E (front to rear).
- 240" & 300" - E-I-E-I-E-I-E-I-E-I-E-I-E-I-E-I (front to rear).

SPARKS PLUGS

Gap;	
170"032-.036"
240" F100 & E100 Bus032-.036"
240" F250/350, P350 & E300 Van028-.032"
300" F100032-.036"
300" All Exc. F100028-.032"
Torque.....	15-20 ft. lbs.

Spark Plug Type

Application	Autolite No.
170"	BRF-82
240";	
F100 & E100 Bus.....	BF-42
F250/350, P350 & E300 Van.....	BTF-31
300";	
F100.....	① BTF-42
All Exc. F100	BTF-31

① - BF-42 on Calif. F100 only.

DISTRIBUTOR

Point Gap;	
170"027"
240" F100 & E100 Bus027"
240" F250/350, P350 & E300 Van025"
300"027"
Cam Angle;	
170" & 300"	33-38°
240" F100 & E100 Bus	33-38°
240" F250/350, P350 & E300 Van	34-39.5°
Breaker Arm Spring Tension	17-21 ozs.
Condenser Capacity21-.25 mfd.

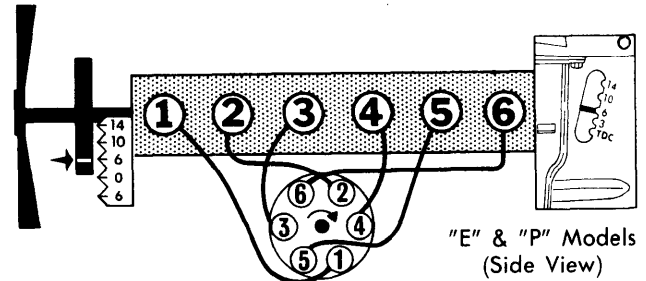

FIRING ORDER & TIMING MARKS

IGNITION TIMING

With engine at normal operating temperature, disconnect distributor vacuum line(s) and plug line(s). Install timing light to number one spark plug. Check and adjust timing at 600 RPM.

Application	Timing Degrees BTDC
All Models.....	6°

HOT (SLOW) IDLE RPM

Set parking brake and bring engine to normal operating temperature. Check timing and dwell and install a tachometer. Place automatic transmission in "D" or manual transmission in neutral. Turn headlights to high beam and air conditioning "OFF". With air cleaner installed, adjust curb idle RPM to specifications. On engines equipped with idle stop solenoid, turn solenoid plunger screw in or out to obtain specified RPM. Disconnect solenoid lead wire at bullet connector, then adjust carburetor throttle stop screw to obtain 500 RPM. Reconnect

1971 Ford 6 Tune-Up

TUNE-UP (Cont.)

solenoid lead wire and open throttle slightly by hand so solenoid plunger may extend. Adjust mixture screw for smoothest idle within range of idle limiter caps.

Hot (Slow) Idle RPM

Application	Man. Trans.	Auto. Trans.
170"	775	
240";		
P350, F250/350 & E300 Van	600	550
F100 & E100/300 Bus.	Ⓢ500-850	Ⓢ500-600
300";		
P350 & F250/350	600	550
F100	Ⓢ500-775	500-550

Ⓢ — Higher RPM with solenoid energized and lower RPM with solenoid de-energized.

IDLE MIXTURE ADJUSTMENT

EXHAUST GAS ANALYZER PROCEDURE

Install a suitable calibrated exhaust gas analyzer. With air cleaner installed, take an analyzer reading. Adjust idle mixture screw within range of limiter cap to specified air/fuel ratio. Correct for any changes in engine idle RPM immediately as idle mixture screw is turned.

NOTE — Allow at least ten seconds following each mixture adjustment for analyzer to properly respond and stabilize.

Idle Limiter Cap — If proper air/fuel mixture cannot be achieved within limits of idle limiter cap, remove cap and adjust mixture screw until proper air/fuel mixture is achieved. Replace with a colored idle mixture limiter cap.

Application	Air/Fuel Ratio
170"	14.5
240";	
All Exc. P350	14.5+
P350	13.65
300";	
P350	13.65
F100	14.5+
F250/350 & F250 (4x4)	13.7

Application	Percentage of CO
170"	1.0
240";	
All Exc. P350	0.5
P350	2.5
300";	
All Exc. F100	2.5
F100	0.5

DISTRIBUTORS

Application	Ⓢ Ford Part No.	
	Man. Trans.	Auto. Trans.
170"	C9UF-F, C8DF-A	
240"	C9UF-A, C8AF-A	C9UF-A, C8AF-A, D1TF-CA
300"	C8TF-D, U, C8AF-A	C8TF-D, U, C8AF-A

Ⓢ — Basic part number is 12127.

Other Data & Specifications — See Tune-Up & Ford Distributors in ELECTRICAL Section.

COLD (FAST) IDLE RPM

Manual Choke — Open throttle valve and hold choke valve fully closed to allow fast idle cam to revolve to fast idle position. Bend choke connector rod until there is light contact between fast idle arm and stop on carburetor body.

Automatic Choke — With hot (slow) idle speed properly adjusted, install a tachometer and bring engine to normal operating temperature. Manually rotate fast idle cam until fast idle screw rests on proper step of cam. Adjust fast idle screw until specified cold (fast) idle RPM is achieved.

Application	Fast Idle RPM
170"	1250
240"	1750
300";	
F100 Man. Trans.	1400
F100 Auto. Trans.	1600
F250/350	1400

GOVERNOR ADJUSTMENTS

240" & 300" — On vehicles equipped with conventional velocity governor, connect a tachometer to engine. With engine at normal operating temperature and throttle at wide open position, compare RPM with operating range stamped on governor plate. If adjustment is required, remove governor seal. To increase RPM, turn cap counterclockwise and clockwise to decrease RPM. With adjustment completed, stop engine and seal cap.

FUEL PUMP PRESSURE & VOLUME

Pressure (At 500 RPM)	4-6 lbs.
Volume	1 pt. in 30 sec.

MANIFOLD HEAT CONTROL VALVE

240" & 300" — Check valve for freedom of movement and lubricate with a suitable solvent (Rotunda COAZ-19A501-A).

EMISSION CONTROL

See appropriate article in EMISSION CONTROL Section.

IGNITION

IGNITION COIL

Application	Ⓢ Ford Part No.
Conventional	B6A-B
Transistorized	C3TZ-A

Ⓢ — Basic part number is 12029.

Resistance	Ohms @ 75°F
Conventional;	
Primary	1.40-1.54
Secondary	7600-8800
Transistorized;	
Primary	226-251
Secondary	4900-5680

CARBURETION

CARBURETORS

①Carter Model YF 1-Bbl.

Application	Man. Trans.	Auto. Trans.
170"	D1BF-CA	
240"	D1TF-YA, VA	D1TF-YA, XA, D1UF-TA, C9TF-E
300"	D1TF-AVA, ZA	D1TF-AVA, AAA, C9TF-F

① - Basic part number is 9510.

Other Data & Specifications - See Tune-Up and Carter Carburetors in CARBURETION Section.

ACCELERATOR AND DOWNSHIFT LINKAGE ADJUSTMENT

E100 240" & 300" - Remove engine cover and air cleaner. Place accelerator pedal in wide open position and check throttle valve position. Loosen throttle cable clamp and move cable

in or out until throttle valve is wide open. Tighten throttle cable clamp. On 240" engines with automatic transmission, hold accelerator pedal in wide open positions. Disconnect downshift rod at transmission downshift lever. Move downshift rod to maximum rearward position. Move transmission downshift lever to maximum forward position. Adjust downshift rod trunnion so that it slips freely into downshift lever, then lengthen rod one or two turns of the trunnion. Tighten and reinstall trunnion and downshift rod.

F100/350, F100 & 250 (4x4) 240" & 300" (Man. Trans.) - Disconnect clip at end of stabilizer rod. Insert .185-.188" diameter pin thru three holes in bellcrank and bracket assembly. Adjust length of stabilizer assembly so rod enters bracket freely. Install clip at end of stabilizer rod and remove .185-.188" pin. Depress accelerator pedal to floor. Bring carburetor throttle lever to wide open position (against stop), by pushing rearward on bellcrank assembly. Adjust rod assembly to install on ball studs, shorten one turn and install rod.

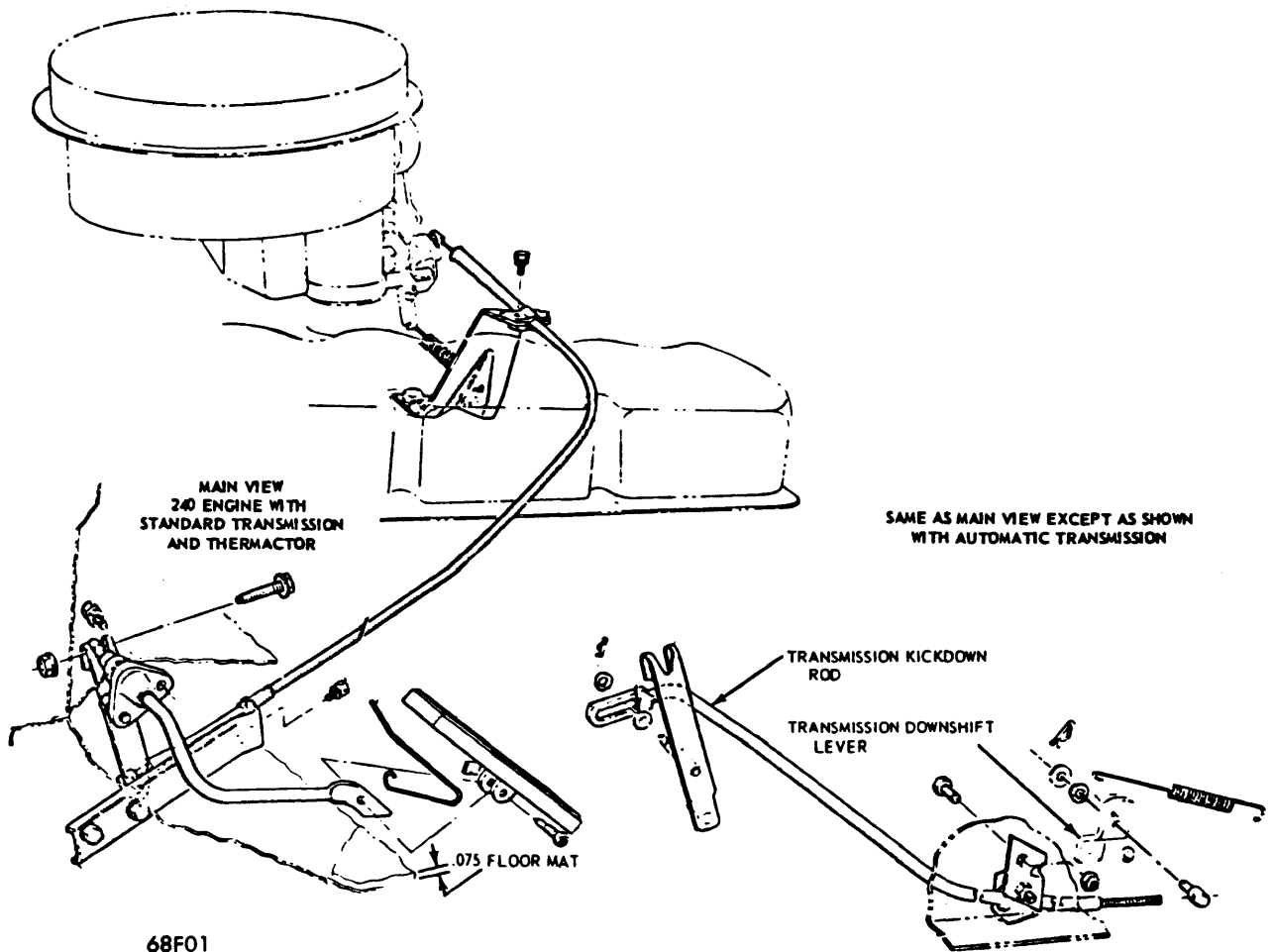

68F01

ACCELERATOR & DOWNSHIFT LINKAGE E100 240"

1971 Ford 6 Tune-Up

CARBURETION (Cont.)

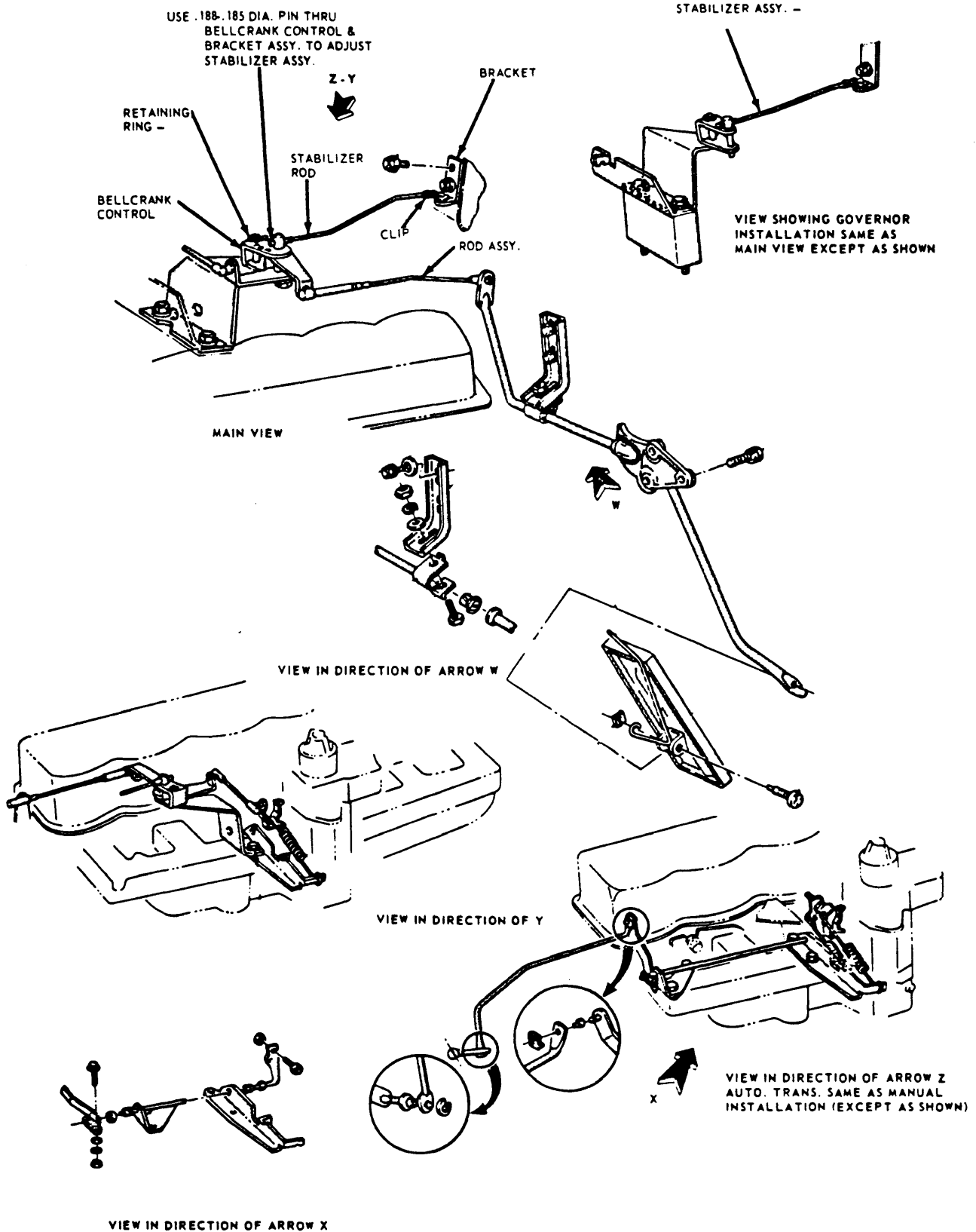

**ACCELERATOR LINKAGE F100/350, F100 & 250
(4x4) 240" & 300" (MAN. TRANS.)**

67F03

CARBURETION (Cont.)

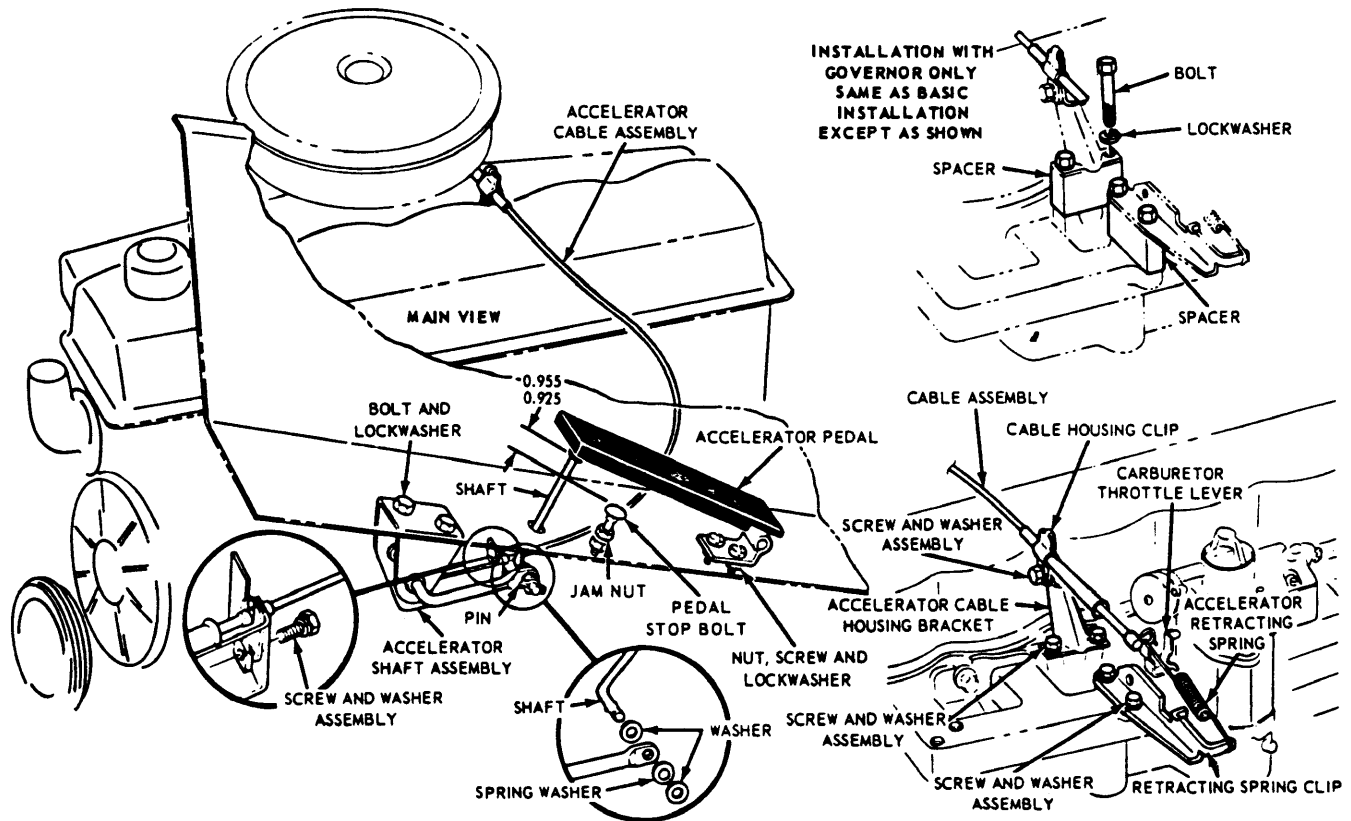

66F02

ACCELERATOR LINKAGE P350 240" & 300" (MAN. TRANS.)

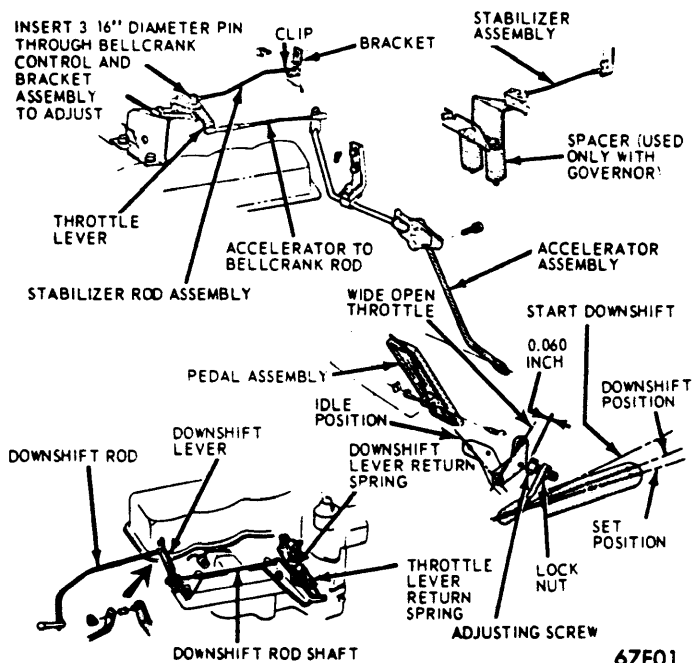

67F01

ACCELERATOR LINKAGE F100/350 (AUTO. TRANS.)

F100/350 (Auto. Trans.) – Disconnect clip from bracket assembly. Insert $\frac{3}{16}$ " diameter pin through holes in bellcrank assembly. Adjust bellcrank stabilizer so that rod fits freely into bracket. Install clip and remove pin. Disconnect accelerator-to-bellcrank rod from bellcrank. Depress accelerator pedal to floor. Move throttle lever to wide open position. Adjust so that rod fits freely on ball stud, then shorten rod one complete turn and install. Hold throttle in wide open position. Hold a .060" feeler gauge between throttle lever and adjustment screw (see illustration). Loosen adjusting screw lock nut. Turn adjusting screw to place downshift lever on transmission against internal stop. Tighten adjusting screw lock nut.

P350 240" & 300" – With idle speed and fuel mixture properly adjusted, loosen jam nut and adjust pedal stop bolt (see illustration). Tighten jam nut. Disconnect accelerator return spring and loosen accelerator cable clamp. Depress accelerator pedal to stop and slide cable rearward until throttle is wide open. Tighten cable clamp and reinstall return spring. On automatic transmission, hold throttle in wide open position. Place a .060" feeler gauge between throttle lever and adjusting screw. Loosen lock nut and adjust screw until downshift lever on transmission is against internal stop. Tighten lock nut and remove feeler gauge.

1971 Ford 6 Tune-Up

CARBURETION (Cont.)

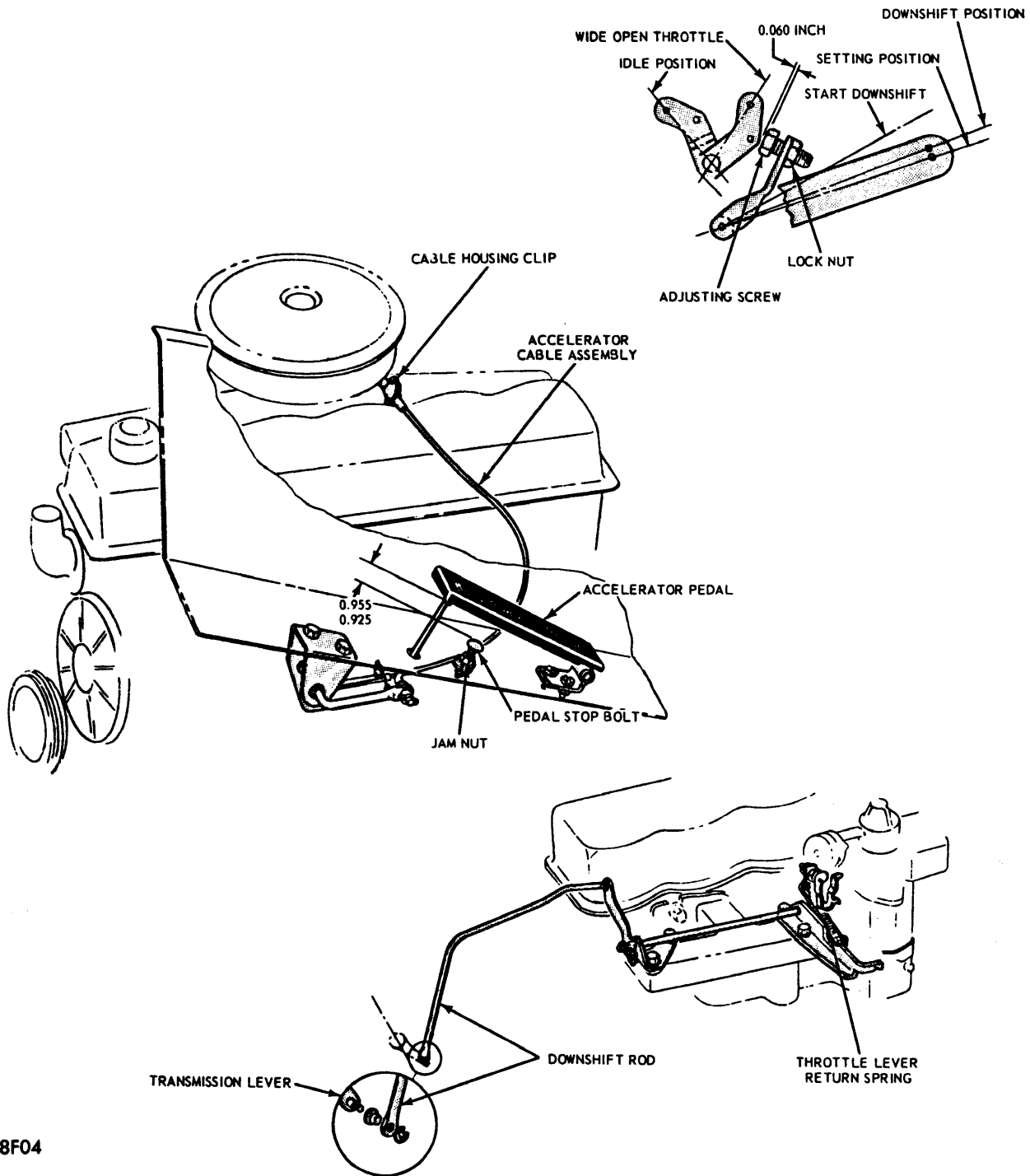

68F04

ACCELERATOR LINKAGE P350 240" & 300" (AUTO. TRANS.)

U100 Hand Throttle – With throttle valve completely closed and throttle knob pressed against instrument panel, loosen hand throttle cable clamp at accelerator lever. Loosen hand throttle lever clevis to cable screw. Hold hand throttle lever stop against accelerator lever and bracket. Pull hand throttle cable tight in clevis. Tighten clevis screw and cable clamp screw.

U100 – Loosen accelerator cable clamp. With choke valve fully open and throttle valve completely closed, slide cable housing rearward until accelerator cable bottoms against cable sleeve. Tighten cable clamp.

CARBURETION (Cont.)

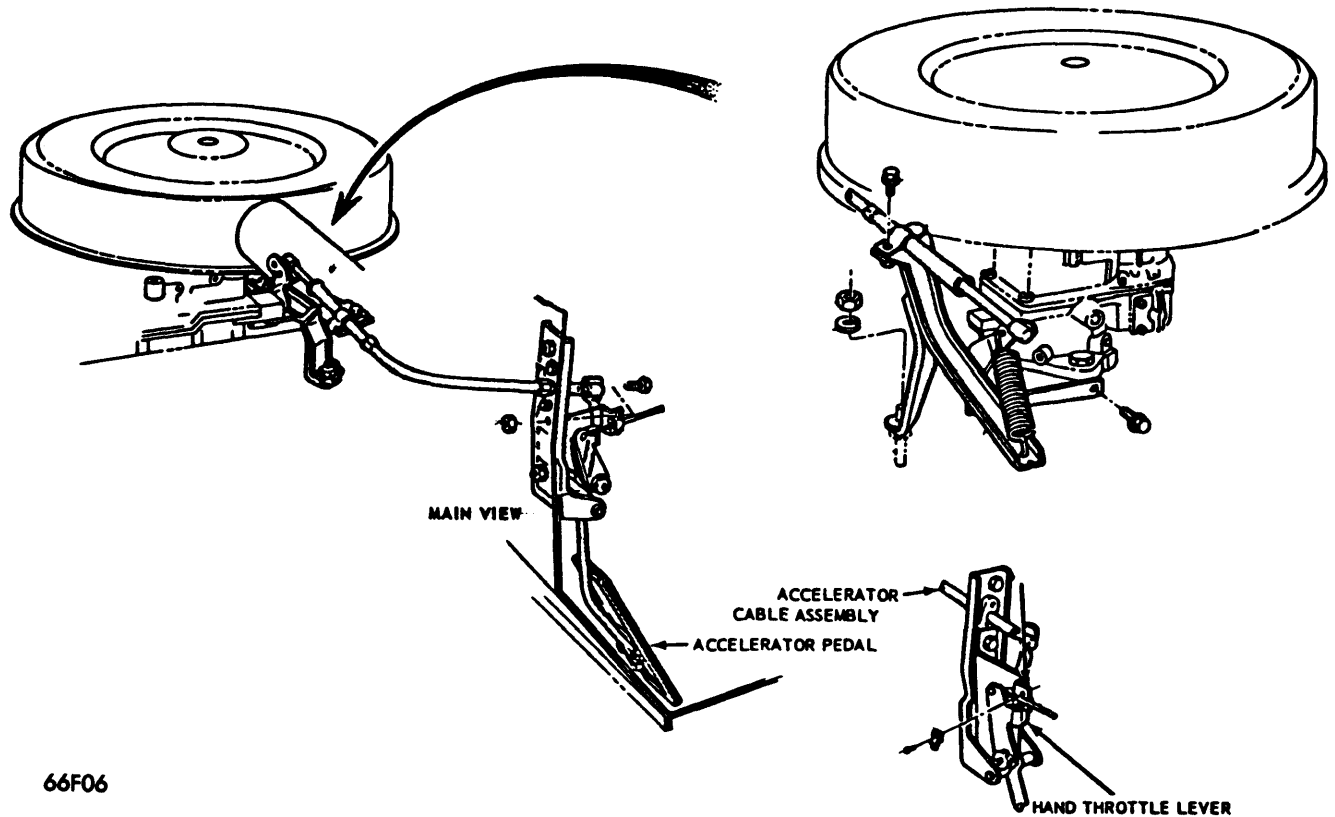

66F06

ACCELERATOR LINKAGE U100 170"

ELECTRICAL

BATTERY

12 Volt - Negative Ground.

Filler Caps	Plates	Capacity Amps.
Yellow	54	45
Red	66	55
Red	66	70
Yellow	78	70

STARTER

Application	①Ford Part No.
E100 170"	C30Z-C
U100	C60Z-A
E, P, F100/350 (Man. Trans.) 240" & 300"	C5TZ-D
E, P, F100/350 (Auto. Trans.) 240" & 300"	C20Z-B

① - Basic part number is 11002.

Other Data & Specifications - See Ford Starters in ELECTRICAL Section.

ALTERNATOR

Application	Amps. & I.D. Color	①Ford Part No.
F100/250	②38 Purple	DOAZ-E
U100 & F100/250	③38 Purple	D2AZ-C
F100/350 & P350	④42 Orange	D2AZ-C
E, P, F100/350	②42 Orange	DOAZ-E
E, P, F100/350	②55 Red	DOAZ-F
E, P, F100/350	③55 Red	D2AZ-D
F100/350	③65 Black	D1AZ-A
F100 & P350	④70	D1AZ-A

① - Basic part number is 10346.

② - Before serial number N20,001.

③ - From serial number N20,001.

④ - Except F100 A/C.

Other Data & Specifications - See Motorcraft Alternators in ELECTRICAL Section.

ALTERNATOR REGULATOR

Application	①Ford Part No.
All Models (Exc. Alt. No. D1AZ-A)	C3SZ-B
F100/350 & P350 (Std. for Alt. No. D1AZ-A)	②C6AZ-A

① - Basic part number is 10316.

② - Transistorized.

Other Data & Specifications - See Motorcraft Alternator Regulators in ELECTRICAL Section.

1971 Ford 6 Tune-Up

ENGINE

INTAKE MANIFOLD TIGHTENING

Working from the center outward, tighten nuts and bolts to specifications.

Intake Manifold Tightening (Ft. Lbs.)

Application	Intake	Exhaust
170"	13-18	13-18
240" & 300"	28-33	23-28

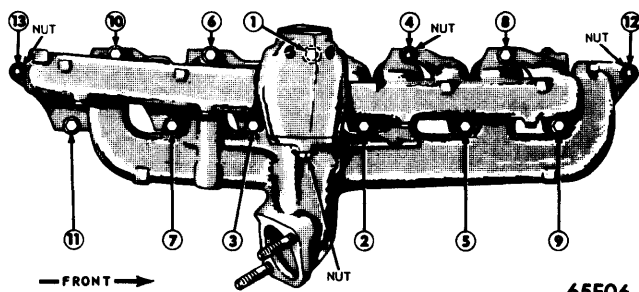

INTAKE & EXHAUST MANIFOLD TIGHTENING SEQUENCE 240" & 300"

CAPACITIES (EXCEPT COOLING)

Application	Quantity
Crankcase ⓐ	
170"	6 qts.
240"	ⓑ5 qts.
300"	5 qts.
Fuel Tank	
U100	12.75 gal.
E100	21 gal.
F250/350 (Cab Models)	19.5 gal.
P350	17 gal.
F250 & 350 (Cowl or Windshield Models)	17 gal.
F100	18.5 gal.
Drive Axles	ⓒ
Transfer Case	
F100	1.25 pts.
F250	4.5 pts.
U100	2.75 pts.
Automatic Transmission	
Ford C-4	10.25 qts.
Ford C-6	12.75 qts.
MX-HD	11 qts.
Manual Transission	
Ford 3.03 U100 & E100	3.5 pts.
Ford 3.03 F100/350 & P350	4 pts.
T-18B	7 pts.
T-85	4 pts.
T-85N (W/Overdrive).....	4.5 pts.
T-87G	5.5 pts.
T-89F	3.75 pts.
New Process 435	7 pts.

ⓐ - Add 1 qt. with filter change.
 ⓑ - F100/250 (4x2) are 4 qts.
 ⓒ - Fill to bottom of filler hole.

BELT ADJUSTMENT

Tension (Lbs.) Using Strand Tension Gauge

New	110-140 lbs.
Usedⓐ	80-100 lbs.

ⓐ - Belt run for a minimum of 10 minutes.

FILTERS & CLEANERS

Filter or Cleaner	Service Interval (Miles)
Oil Filter.....	ⓐⓑ6000
Air Cleaner (Oil Bath).....	ⓐ6000
Air Cleaner (Dry Type).....	12,000
Crankcase Breather	ⓐ6000
Fuel Filter.....	ⓑ12,000
Emission Breather (In Air Cleaner).....	Replaceⓐⓑ6000

ⓐ - More often under dusty conditions, trailer towing or stop and go driving.

ⓑ - 24,000 miles F100/350.

ⓒ - 4000 miles on F350 with dual wheels.

ⓓ - 24,000 miles on F100/350 & P350.

COOLING CAPACITIES

Application	ⓐQuantity (Qts.)
U100 170"	9.1
E100 240"	14.1
E100 240" E.C. or Auto. Trans.....	14.4
E100 240" A/C.....	16.7
F100/250 240" & 300" (4x4) Man. Trans.....	14.4
F100/250 240" & 300" (4x4) E.C. or Auto. Trans..	16.75
F100/250 240" Man. Trans.	14.1
F100/250 240" & 300 Auto. Trans.....	14.4
F100/250 240" & 300" E.C. W/Auto. Trans.....	16.7
F100/250 240" & 300" A/C.....	16.7
F100/250 240" E/C/ W/Man. Trans.	14.4
F100/250 300" Man. Trans.	14.4
F100/250 300" E.C. W/Man. Trans.	16.7
F350 Man. Trans.....	ⓑ14.4
F350 E/C. W/Man. Trans.....	ⓒ16.7
F350 Auto. Trans.....	16.7
F350 E.C. W/Auto. Trans.....	18.3
P350.....	18.1

ⓐ - Includes 1 qt. for std. heater.
 ⓑ - With dual rear wheels 16.7 qts.
 ⓒ - With dual rear wheels 18.3 qts.