

## TUNE-UP

### ENGINE IDENTIFICATION

Engine code letters are suffix of Engine Identification Number. Number is stamped on a pad on front right hand side of cylinder block.

Application	Code
307" Man. Trans. ....	UP, UB, UH
307" Man. Trans. W/A.I.R. ....	UO, UA, UG
307" Auto. Trans. ....	UQ, UN, UC, UI
307" Auto. Trans. W/A.I.R. ....	UF, UE, UD, UL
350" Man. Trans. ....	WO, XX, XB, WI
350" Man. Trans. W/A.I.R. ....	WI, WN, XW, XA, WH
350" Auto. Trans. ....	WP, XY, XD, XC, WK, WJ
350" Auto. Trans. W/A.I.R. ....	WQ, XF, WA, XZ, WM, WL
396" Man. Trans. ....	YS
396" Man. Trans. W/A.I.R. ....	YQ
396" Auto. Trans. ....	YR
396" Auto. Trans. W/A.I.R. ....	YP

### MODEL IDENTIFICATION

#### VEHICLE IDENTIFICATION NUMBER

The Vehicle Identification Number is found on the GVW Rating Plate. Plate is attached to left hand door pillar on all models except "P" and cowl models. Plate location on "P" and cowl models is determined by body builder.

CM20DPA10001

- First Digit - Chassis Designation.
- Second Digit - Engine Designation.
- Third & Fourth Digits - GVW Range (Series Designation).
- Fifth Digit - Truck Type.
- Sixth Digit - Assembly Plant.
- Seventh Digit - Model Year (1969).
- Remaining Digits - Sequence Built Number.

### TUNE-UP NOTES

► **IDLE SPEED ADJUSTMENT CAUTION** - Procedures and specifications for idle speed adjustment must be followed exactly as outlined. See "Hot (Slow) Idle RPM" under Tune-Up.

**NOTE** - For other items affecting Tune-Up, see CARBURETION Section or EMISSION CONTROL Section.

### COMPRESSION PRESSURE

With air cleaner removed and throttle and choke wide open, crank engine through at least four compression strokes. Compression should be 150 psi with a maximum variation of 20 psi between cylinders.

### VALVE TAPPET CLEARANCE

Hydraulic Lifters ..... One turn down from zero lash.

#### VALVE ARRANGEMENT

307" & 350"

E-I-E-I-E-I-E-I-E (Both banks, front to rear.)

396"

E-I-E-I-E-I-E-I (Left bank, front to rear.)

I-E-I-E-I-E-I-E (Right bank, front to rear.)

### SPARK PLUGS

Gap ..... .035"  
Torque..... 25 ft. lbs.

#### Spark Plug Type

Application	AC No.
307" .....	R44S
350" .....	CR43
396" .....	R43N

### DISTRIBUTOR

Point Gap  
New ..... .019"  
Used ..... .016"  
Cam Angle..... 28-32°  
Breaker Arm Spring Tension ..... 19-23 ozs.  
Condenser Capacity ..... .18-.23 mfd.

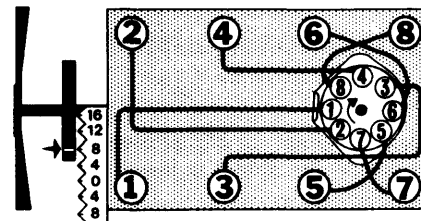

9CHA01

### FIRING ORDER & TIMING MARKS

### IGNITION TIMING

Ignition timing is checked or adjusted with engine at normal operating temperature, distributor vacuum line disconnected and plugged and engine at normal idle.

Application	Timing
307" .....	2° BTDC
350" & 396" .....	4° BTDC

### HOT (SLOW) IDLE RPM

Start engine and warm to normal operating temperature. Idle speed is checked or adjusted with engine at normal operating temperature, air conditioning "ON", dwell and timing correctly adjusted, air cleaner installed, choke open, manual transmission in Neutral and automatic transmission in "D". If carburetor is equipped with a dashpot, adjust dashpot until contact between plunger and throttle lever is eliminated. Adjust idle speed screw to obtain specified idle RPM. Adjust mixture screws out to obtain maximum idle speed. Now adjust mixture screws in until engine speed drops 20 RPM.

**Idle Speed Solenoid Adjustment (If Equipped)** - With idle speed RPM correctly adjusted, adjust solenoid plunger with a wrench until it just contacts throttle lever. Disconnect solenoid electrical lead and adjust idle speed screw until an engine speed of 400 RPM is obtained. Reconnect solenoid lead. Idle RPM should be as specified.

# 1969 GMC V8 Tune-Up

## TUNE-UP (Cont.)

### Idle Speed (RPM)

Application	RPM
307" W/O Emission Control.....	550
307" W/Emission Control	
Man. Trans. ....	700
Auto. Trans. ....	600
350" All .....	500
396" All	
Man. Trans. ....	700
Auto. Trans. ....	600

### COLD (FAST) IDLE RPM

Rochester Model 2G 2-Bbl. — Fast idle RPM is correct when slow idle RPM is correctly adjusted. See *Hot (Slow) Idle RPM* in this Section.

Rochester Model 4MV 4-Bbl. — Fast idle speed is checked or adjusted with engine at normal operating temperature, choke valve open, transmission in Neutral and fast idle lever on high step of fast idle cam. Adjust fast idle screw to obtain an engine speed of 2400 RPM.

## GOVERNOR ADJUSTMENT

### SPEED ADJUSTMENT

307" — To adjust governor for higher speed, rotate adjusting cap counterclockwise. To obtain a lower speed, rotate cap clockwise.

### SURGE & STABILITY ADJUSTMENT

307" — If a surging condition exists, remove adjusting cap and shaft assembly. Using a suitable hollow wrench (A-24283),

hold nut in bore and rotate screw one turn to right with a suitable hex wrench (A-25264). Now turn nut ¼ turn to right without turning screw. If a more sensitive adjustment is required, use same procedures and turn screw and nut to left. Tap lightly on wrench securing nut to ensure nut is seated correctly. Replace shaft assembly and adjusting cap.

## CHOKE ADJUSTMENT

**Manual Choke** — To adjust choke, push knob into stop then pull out ⅛". Loosen cable clamp at carburetor bracket and adjust cable through clamp until choke valve is fully open and tighten clamp. Make sure choke valve fully opens and closes as cable is actuated.

**Automatic Choke** — With air cleaner removed, check that choke valve and rod move freely. Disconnect choke rod at choke lever. Hold choke valve in fully closed position and pull choke rod upward to end of travel. The bottom of choke rod should be even with top of hole in choke lever. To adjust, bend rod at offset until it freely enters hole in choke lever. Reconnect rod and install air cleaner.

## FUEL PUMP PRESSURE & VOLUME

Pressure (At Idle)..... 5-6.5 psi  
Volume (At Cranking Speed)..... 1 pt. in 30-45 sec.

## MANIFOLD HEAT CONTROL VALVE

Check valve for freedom of movement and lubricate with a suitable solvent (GM Manifold Heat Control Valve Solvent).

## EMISSION CONTROL

See appropriate article in *EMISSION CONTROL* Section.

## IGNITION

### DISTRIBUTOR

Application	Delco Part No.
307.....	1111481
350" 2-Bbl. ....	1111495
350" 4-Bbl.	
Man. Trans. ....	1111956
Auto. Trans. ....	1111955
396" .....	1111500

**Other Data & Specifications** — See *Tune-Up and Delco Distributors* in *ELECTRICAL* Section.

### IGNITION COIL

Application	Delco Part No.
All .....	1115238
<b>Resistance</b>	<b>Ohms @ 75°F</b>
Primary .....	1.77-2.05
Secondary .....	3,000-20,000
Ballast Resistor Loom.....	1.8

## CARBURETION

### CARBURETORS

#### Rochester Model 2G & 2GV 2-Bbl.ⓐ

Application	Carb. No.
307" G-1500 (Man. Choke).....	7029125
307" All Others (Man. Choke).....	7029107
307" W/Gov. (Man. Choke).....	7029108
307" All (Auto. Choke).....	7029105
350" All (Auto. Choke).....	7029121

ⓐ — G designates manual choke and GV designates automatic choke.

#### Rochester Model 4MV 4-Bbl.

Application	Carb. No.
350" All .....	7029223
396" All .....	7029214

**Other Data & Specifications** — See *Tune-Up and Rochester Carburetors* in *CARBURETION* Section.

## CARBURETION (Cont.)

### ACCELERATOR LINKAGE ADJUSTMENT

**All (Exc. "G" Models)** – With accelerator pedal depressed to floor and throttle lever in wide open position, adjust swivel on rod until it freely enters hole in throttle lever or pedal lever.

**"G" Models** – Disconnect swivels "D" and "J" from their respective levers (see illustration). Insert a  $\frac{3}{16}$ " diameter gauge pin in hole "B" on lever "A" and accelerator pivot bracket. Rotate throttle lever to wide open position and adjust swivel "D" until it freely enters hole in lever "A". Depress accelerator pedal until it is  $\frac{1}{4}$ " from floor and adjust swivel "J" until it freely enters hole in lever "A". Install clips on swivel and remove gauge pin.

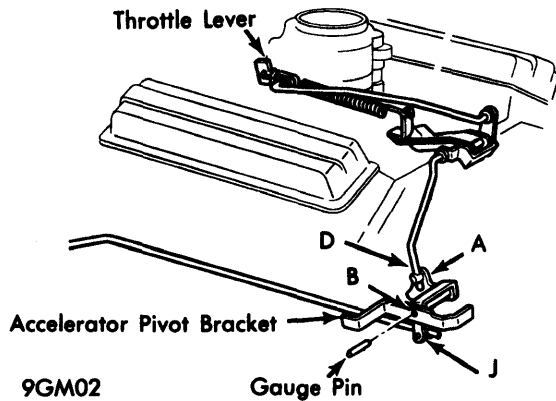

### "G" MODELS ACCELERATOR LINKAGE ADJUSTMENT

### THROTTLE VALVE LINKAGE ADJUSTMENT

**C-1500 & 2500** – To check linkage adjustment, place linkage in idle position then rotate to wide open by rotating lever "A" (see illustration). Push down on lever "C" and check that rod "B" does not flex. If rod flexes, disconnect swivel on rod "B" from lever "A". Rotate lever "A" to wide open position and pull forward on rod "B" until internal stop in transmission is felt. Adjust swivel on rod "B" until it freely enters hole in lever "A". Check and adjust accelerator linkage if necessary. See *Accelerator Linkage Adjustment*.

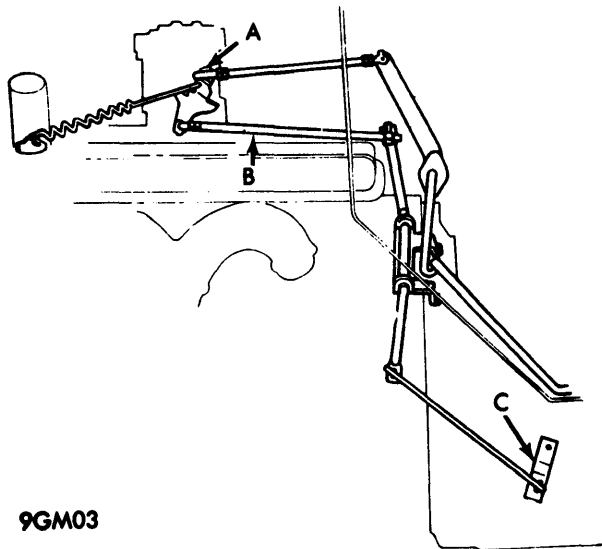

9GM03  
C-1500 & 2500  
THROTTLE VALVE LINKAGE ADJUSTMENT

**P-2500** – To check adjustment, place linkage in idle position then rotate to wide open position by rotating lever "A" (see illustration). Push down on lever "B" and check that rod "C" does not flex. If rod "C" flexes, disconnect rod from lever "B". Rotate levers "A" and "B" to wide open positions. Push rod "C" up until slot is against pin and adjust swivel until it freely enters hole in lever "B". Check and adjust accelerator linkage if necessary. See *Accelerator Linkage Adjustment*.

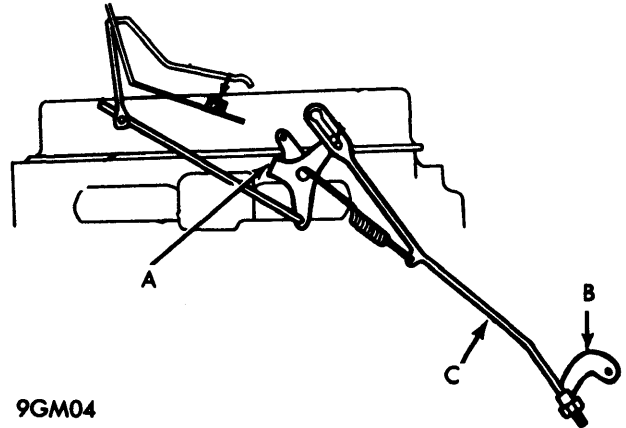

### P-2500 THROTTLE VALVE LINKAGE ADJUSTMENT

**G-1500 & 2500** – Check and adjust accelerator linkage. See *Accelerator Linkage Adjustment*. To adjust throttle valve linkage, insert a  $\frac{3}{16}$ " gauge pin in hole in lever "A" (see illustration) and bracket "B" with lever "E" turned counterclockwise to internal stop in transmission. Adjust swivel "C" on rod "D" until it freely enters hole in lever "E", then lengthen rod by turning swivel three turns. Remove gauge pin and connect swivel to lever.

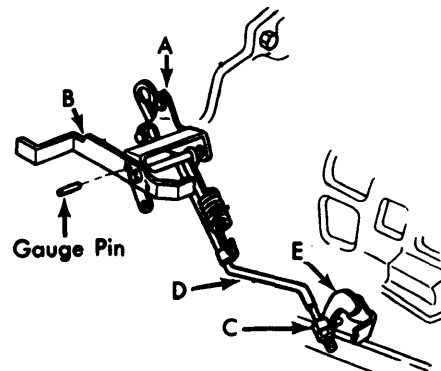

9GM05  
G-1500 & 2500  
THROTTLE VALVE LINKAGE ADJUSTMENT

### DETENT SWITCH ADJUSTMENT

**Turbo Hydra-Matic Trans. Only** – With carburetor in wide open position, adjust switch on mount until specified clearance is obtained between switch plunger and carburetor lever.

#### Detent Switch Clearance

Application	Clearance
307" .....	.050"
350" & 396" .....	.200"

# 1969 GMC V8 Tune-Up

## ELECTRICAL

### BATTERY

12 Volt - Negative Ground.

Application	Delco Part No.	Cranking Power Watts @ 0°F
"G" Models.....	Y-55.....	2300
307" All Others.....	Y-59.....	2350
350", 396" All.....	R-59.....	2900
Optional All.....	R-69.....	3150

### STARTER

Application	Delco Part No.
"G" Models.....	1108338
All Others 307" & 350"	
Man. Trans. ("P" Models W/350").....	1108362
Man. Trans. (All Others).....	1108368
Auto. Trans. 307"	
Pow-R-Flo.....	1108367
Turbo Hydra-Matic.....	1108418
Auto. Trans. 350".....	1108361
396" All.....	1108385
Optional	
For Starter No. 1108338 & 1108418.....	1108350
For Starter No. 1108362 & 1108385.....	1108364
For Starter No. 1108368 & 1108361.....	1108372
For Starter No. 1108367.....	1108363

Other Data & Specifications - See Delco Starters in ELECTRICAL Section.

### ALTERNATOR

Application	Amps.	Delco Part No.
Standard (Exc. "P").....	37.....	1100834
Optional (Std. "P").....	42.....	1100839
Optional (Exc. "G").....	61.....	1100849
Optional ("G").....	61.....	1100843
Optional (All).....	62.....	1117782

Other Data & Specifications - See Delco Alternators in ELECTRICAL Section.

### ALTERNATOR REGULATORS

Application	Delco Part No.
All (Exc. 62 Amp. Alt.).....	1119515
62 Amp. Alt. ....	1116378

Other Data & Specifications - See Delco Alternator Regulators in ELECTRICAL Section.

## ENGINE

### INTAKE MANIFOLD TIGHTENING

Tighten bolts to 30 ft. lbs. in sequence shown in illustration.

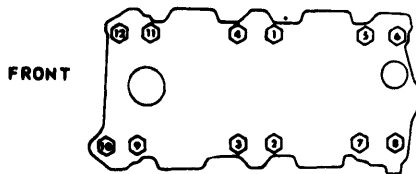

9GM06

### 307" & 350" INTAKE MANIFOLD TIGHTENING SEQUENCE

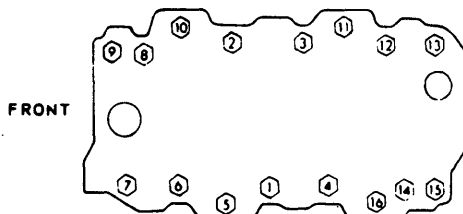

9GM07

### 396" INTAKE MANIFOLD TIGHTENING SEQUENCE

### BELT ADJUSTMENT

Tension (Lbs.) Using Strand Tension Gauge

Application	New Belt	Used Belt
Water Pump.....	125±5.....	75±5
Power Steering.....	125±5.....	75±5
Air Conditioning.....	140±5.....	95±5
A.I.R. Pump.....	75±5.....	55±5

### COOLING CAPACITIES

Application	Quantity
307"	
C-1500 Man. Trans. ....	16.5 qts.
K-1500 & 2500.....	17.5 qts.
All Others.....	17 qts.
350"	
K-1500.....	18 qts.
K-2500.....	16.5 qts.
All Others.....	16 qts.
All Others <sup>②</sup> .....	17.5 qts.
396"	
Man. Trans. ....	23 qts.
Auto. Trans. ....	24.5 qts.

① - Add one quart if equipped with heater.

② - With heavy duty radiator.

## ENGINE (Cont.)

### CAPACITIES (EXCEPT COOLING)

Application	Quantity
Crankcase .....	① 4 qts.
Automatic Transmission	
Pow-R-Flo .....	9 qts.
Turbo Hydra-Matic .....	9.5 qts.
Manual Transmission	
3-Speed .....	2 pts.
Heavy Duty 3-Speed .....	2.75 pts.
Heavy Duty 3-Speed With O.D. ....	3.25 pts.
Borg Warner 3-Speed .....	3.5 pts.
4-Speed .....	8 pts.
New Process 4-Speed .....	7 pts.
Four Wheel Drive Transfer Case .....	5 pts.
Drive Axles .....	②
Fuel Tank	
"C" & "K" Models .....	22 gals.
"G" Models .....	24.5 gals.
Cowl Models .....	20 gals.
P-1500 .....	20.5 gals.
P-2500 & 3500 .....	30 gals.

- ① - Add one quart with filter change.
- ② - Fill to bottom of filler plug hole.

### FILTERS & CLEANERS

Filter or Cleaner	Service Interval (Miles)
Oil Filter .....	Replace 12,000
Air Cleaner	
Oil Bath Type .....	① Check 12,000
Element Type .....	② Replace 24,000
Foam Type .....	Clean 12,000
Crankcase Ventilation Filter .....	③ Clean 6,000
Crankcase Ventilation Valve .....	Replace 12,000
Governor Filter .....	Replace 12,000
A.I.R. Filter .....	Clean 12,000
Turbo Hydra-Matic Sump Strainer .....	Replace 24,000
Fuel Filter .....	Replace 12,000
Distributor Cam Lubricator .....	Replace 24,000

- ① - Clean and replace with SAE 50 oil.
- ② - Replace if dirty, do not clean.
- ③ - If equipped, clean and replace with SAE 20 oil.