

## TUNE-UP

### ENGINE IDENTIFICATION

Engine model and serial numbers are stamped on a pad located in right upper rear corner of cylinder block. Engines also have an option plate attached to rocker cover, which notes optional equipment. Option plate also includes model and serial numbers.

### ENGINE MODEL IDENTIFICATION

5047-7040

- First Digit - Series 53.
- Second & Third Digit - Number of cylinders.
- Fourth Digit - Automotive.
- Fifth Digit - Basic engine arrangement; Rotation: R - (right) viewed from front of engine. Type: A and C designates location of super-charger and exhaust manifold viewed from rear of engine (see illustration).
- Sixth Digit - Design variations; 5067-5040 - "N" engine. 5067-5240 - 4 valve head.
- Seventh & Eighth Digit - Specific model number and starter/super-charger arrangement; Odd number designates starter opposite super-charger. Even number designates starter on same side as super-charger.

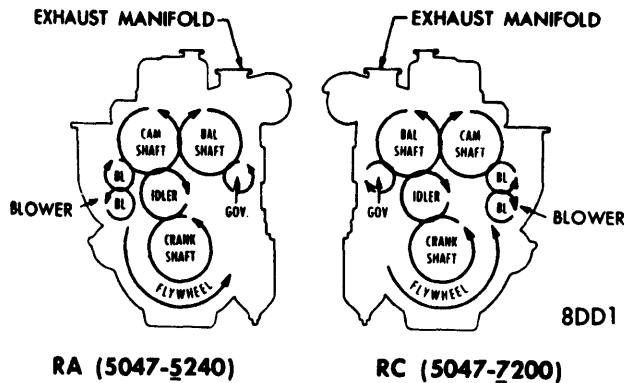

BASIC ENGINE ARRANGEMENT

### MODEL IDENTIFICATION

PT20HPB1001

- First Digit - Chassis type (Forward Control).
- Second Digit - Engine type (In-line 3-Cyl. diesel).
- Third & Fourth Digit - GVW range number.
- Fifth Digit - Body and brake (Panel square front).
- Sixth Digit - Assembly plant (Pontiac).
- Seventh Digit - Model year.
- Remaining Digits - Serial number.

### TUNE-UP NOTES

**NOTE** - It is necessary to follow tune-up procedures in order listed to achieve correct tune-up. Engine must be at normal operating temperature for all adjustment procedures.

### COMPRESSION PRESSURE

With engine at normal operating temperature, remove fuel lines from number one injector. Remove injector and install adaptor and pressure gauge from Kit (J 9531-01). Use a spare fuel line and fabricate a jumper connection between fuel inlet and return passages. Start engine and run at 600 RPM. Note and record compression pressure. Pressure reading must not exceed 25 psi between cylinders. Repeat procedure for remaining cylinders.

| Minimum Compression (PSI) | ① Altitude (Ft.) |
|---------------------------|------------------|
| 540.....                  | 0                |
| 500.....                  | 2,500            |
| 465.....                  | 5,000            |
| 430.....                  | 7,500            |
| 395.....                  | 10,000           |

① - Feet above sea level.

### VALVE TAPPET CLEARANCE

#### 4 Valve Cylinder Head

|                            |            |
|----------------------------|------------|
| Exhaust Valves (Hot).....  | .023-.024" |
| Exhaust Valves (Cold)..... | .025-.026" |

#### 2 Valve Cylinder Head

|                            |       |
|----------------------------|-------|
| Exhaust Valves (Hot).....  | .009" |
| Exhaust Valves (Cold)..... | .011" |

### VALVE ARRANGEMENT

All Exhaust Valves.

### INJECTORS

| Application     | Type |
|-----------------|------|
| 159" 3-53N..... | N40  |

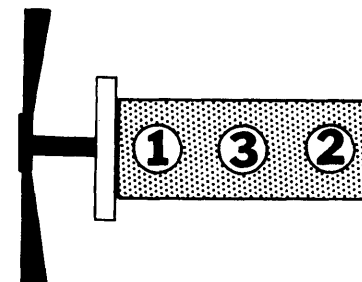

FIRING ORDER (1-3-2) 3-CYL. DIESEL

### INJECTION TIMING

With engine at normal operating temperature, place stop lever in no fuel position. Remove rocker cover and rotate engine until exhaust valves are completely open on the cylinder to be timed. Place small end of injector timing tool (J 1853) in hole in top of injector follower. Loosen push rod lock nut. Turn push rod and adjust injector rocker arm until extended part of tool will just pass over top injector follower. Hold push rod and tighten lock nut. Time remaining injectors in the same manner. Install new gasket and rocker cover.

## TUNE-UP (Cont.)

| Injector | Timing Dimension | Tool No. |
|----------|------------------|----------|
| N40..... | 1.460" .....     | J 1853   |

GOVERNOR & INJECTOR  
RACK ADJUSTMENT

**NOTE** — Two types of governors are used and may be identified by letters D.W.-L.S. (double weight limiting speed) or S.W.-V.S. (single weight variable speed) stamped on name plate.

**Limiting Speed Governor** — 1) Remove high speed spring retainer cover. Back out buffer screw until it extends  $\frac{3}{8}$ " beyond governor housing. Remove rocker cover. Start engine and adjust idle speed screw to obtain an idle of 500-600 RPM.

**NOTE** — Recommended idle speed is 500-600 RPM, but may vary with special engine applications.

2) Stop engine and remove governor cover. Start engine and control speed manually by operating injector control tube lever. Adjust engine speed between 800-1000 RPM. Gap between low speed spring cap and high speed spring plunger should be .0015", adjust gap adjusting screw as required.

3) Install governor cover, making sure speed control lever pin engages slot in differential lever. Install screws and lock washers finger tight. Pull cover away from engine and tighten screws. This will properly locate cover on governor housing.

**Injector Rack Control Levers** — 1) Starting with rear injector rack, disconnect any linkage attached to speed control lever. Loosen all inner and outer injector rack lever adjusting screws. Levers should be free on injection control tube.

2) Move speed control lever to full fuel position. Turn inner adjusting screw down on rear injector rack control lever until increased effort is noted. Turn down outer adjusting screw until it bottoms lightly on injector control tube. Then alternately tighten both inner and outer adjusting screws until they are tight.

3) To be sure of proper rack adjustment, make the following check; Hold speed control lever in full fuel position. Press down on injector rack coupling causing coupling to rotate. Setting is sufficiently tight if coupling returns to its original position, it is too loose if it does not return to its original position. To correct, back off outer adjusting screw slightly and tighten inner screw. Coupling is too tight if, when moving speed control lever from idle to maximum speed position, injector rack coupling becomes tight before speed control lever reaches full travel. Back off inner adjusting screw slightly and tighten outer adjusting screw.

4) Manually hold rear injector control lever in full fuel position and adjust adjacent lever in same manner as rear lever in previous steps. When settings are correct, racks of both injectors must be snug on ball end of their rack control levers. Position remaining racks in a like manner.

**Maximum No-Load Engine Speed** — 1) With engine at normal operating temperature, place speed control lever in maximum speed position and note engine RPM. Stop engine and if necessary, adjust engine to no-load speed.

2) Remove high speed spring retainer, spring and plunger. Remove high speed spring from plunger and add or remove shims to adjust no-load speed.

**CAUTION** — Do not jar assembly while it is being removed, to prevent low speed spring and cap from dropping into governor.

**NOTE** — Shims are available in .010" and .078" thickness. Each .010" shim will increase engine speed by approximately 10 RPM.

3) Replace high speed spring, plunger and retainer in governor and tighten securely. Start engine and recheck no-load RPM.

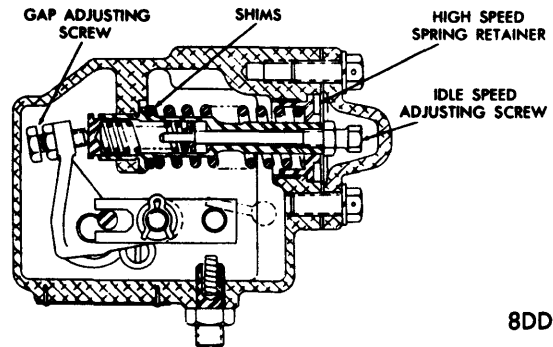

LIMITING SPEED GOVERNOR SPRING ASSEMBLY

**Idle Speed** — 1) With maximum no-load speed properly adjusted, bring engine to normal operating temperature. Back out buffer screw to avoid contact with differential lever. Adjust idle speed screw to obtain 500-600 RPM. Hold idle speed screw and tighten lock nut. Replace high speed spring cover and tighten attaching bolts.

**NOTE** — Recommended idle speed is 500-600 RPM, but may vary with special engine applications.

**Buffer Screw Adjustment** — 1) With maximum no-load speed and idle speed adjustment completed, and engine at normal operating temperature, run engine at idle. Turn buffer screw in so that it contacts differential lever as lightly as possible and still eliminates engine roll.

**NOTE** — Do not increase engine RPM at idle more than 15 RPM with buffer screw.

2) Recheck maximum no-load speed. If it has increased more than 25 RPM, back off buffer screw until increase is less than 25 RPM. Hold buffer screw and tighten lock nut.

**Variable Speed Governor** — 1) After adjusting exhaust valves and timing fuel injectors, disconnect any linkage attached to governor levers. Remove governor cover and place speed control lever in maximum speed position.

2) Insert a .006" feeler gauge between spring plunger and plunger guide, loosen lock nut and adjust screw in or out until a slight drag is noted on feeler gauge. Tighten lock nut and recheck clearance.

Place governor cover on housing, with pin in throttle shaft assembly entering slot in differential lever. Install cover screws and lock washers finger tight. Pull cover assembly in a direction away from engine, to take up slack, and tighten cover screws.

**NOTE** — This step is required since no dowels are used to locate cover on housing.

## TUNE-UP (Cont.)

**Injector Rack Control Levers** – 1) Starting with rear injector rack control lever, loosen lock nut and back buffer screw out approximately  $\frac{3}{8}$ ".

2) Remove valve rocker cover. Loosen all inner and outer injector rack control lever adjusting screws. Be sure all injector rack control levers are free of injector control tube.

3) Move speed control lever to maximum speed position. Move stop lever to RUN position and hold with light finger pressure. Turn inner adjusting screw of rear injector rack control lever down until a slight movement of control is observed or a slight increase in effort to turn screwdriver. This will place rear injector rack in full-fuel position. Turn outer adjusting screw down until it lightly bottoms on injector control tube. Then alternately tighten both inner and outer adjusting screws.

4) Check to see that control lever is properly adjusted by; holding stop lever in RUN position and press down on injector rack with a screwdriver or finger tip causing rack to rotate. Setting is sufficiently tight if rack returns to original position when pressure is released. If rack does not return to its original position, it is too loose. To correct, back off outer adjusting screw slightly and tighten inner adjusting screw. Setting is too tight if, when moving stop lever from STOP to RUN, injector rack becomes tight before stop lever reaches end of its travel. If rack is found to be too tight, back off inner adjusting screw slightly and tighten outer adjusting screw.

5) Manually hold rear injector in full-fuel position with lever on injector control tube. Adjust adjacent rack using same method as before. Recheck rear injector rack to be sure that it has remained snug on ball end of rack control lever. When settings are correct, racks of both injectors must be snug on ball end of their respective levers. Adjust remaining racks as previously described.

**Maximum No-Load Engine Speed** – 1) Maximum no-load speed varies with full load operating speed desired. Use an accurate tachometer to determine maximum no-load speed and with Engine Speed Droop Table make the following adjustments:

### Engine Speed Droop

| Full Load RPM   | Max. Governor Droop RPM |
|-----------------|-------------------------|
| 0-1200 .....    | 125                     |
| 1201-1400 ..... | 135                     |
| 1401-1600 ..... | 145                     |
| 1601-1800 ..... | 155                     |
| 1801-2000 ..... | 165                     |
| 2001-2200 ..... | 175                     |
| 2201-2400 ..... | 185                     |
| 2401-2600 ..... | 195                     |
| 2601-2800 ..... | 205                     |

*Example* – If full load speed is to be 2200 RPM, then the no-load speed should be 2375 RPM,  $2200 + 175 = 2375$  RPM.

2) Disconnect booster spring and stop lever retracting spring. Remove attaching bolts and withdraw variable speed spring housing and variable speed spring retainer located inside of housing. Using shim table, determine shims or stops required for desired full load speed.

**NOTE** – A split stop can only be used with a solid stop.

### Shim Table

| Full Load RPM   | Stops |       | Shims     |
|-----------------|-------|-------|-----------|
|                 | Solid | Split |           |
| 1200-1575 ..... | 1 ..  | 2 ..  | As Needed |
| 1576-2025 ..... | 1 ..  | 1 ..  | As Needed |
| 2026-2625 ..... | 1 ..  | 0 ..  | As Needed |
| 2626-2800 ..... | 0 ..  | 0 ..  | As Needed |

3) Install variable speed spring housing. Connect booster spring and stop lever spring and recheck maximum no-load speed. If required, add shims to obtain necessary operating speed.

**NOTE** – For each .001" in shims added, operating RPM will increase approximately 2 RPM.

**NOTE** – If maximum no-load speed is raised or lowered more than 50 RPM by installation or removal of shims, recheck governor gap. If readjustment of governor gap is required, position of injector racks must be rechecked.

**NOTE** – Governor stops are used to limit compression of governor spring, which determines maximum engine RPM.

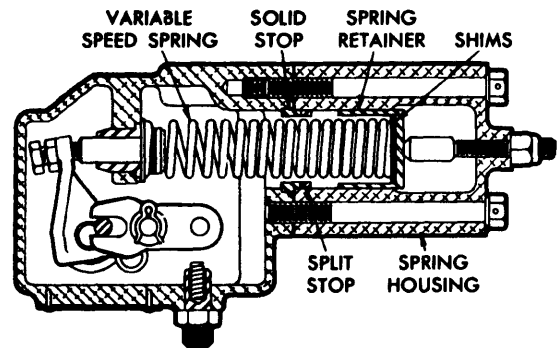

8DD4

### VARIABLE SPEED GOVERNOR SPRING ASSEMBLY

**Idle Speed** – After maximum no-load speed has been set, place stop lever in RUN position and speed control lever in IDLE position. With engine running, loosen lock nut and turn idle speed in or out until engine idles at proper speed. Hold idle screw and tighten lock nut.

**NOTE** – Idle speed is 500 RPM for engines operating up to 2500 RPM or 550 RPM for engines operating at higher speeds. However, idle speed may vary with special engine applications.

**Buffer Screw Adjustment** – With engine idling at proper RPM, loosen lock nut and turn buffer screw in so that it contacts differential lever as lightly as possible and still eliminates engine roll. Hold buffer screw and tighten lock nut.

**NOTE** – Do not raise engine idle speed more than 15 RPM with buffer screw.

# 1968 GMC Diesel 3 Tune-Up

## TUNE-UP (Cont.)

**Booster Spring Adjustment** - 1) With idle speed set, move speed control lever to idle position. Loosen booster spring retaining nut on speed control lever. Loosen lock nuts on eye bolt at opposite end of spring. Move spring retaining bolt in slot of speed control lever until center of bolt is on or slightly over center (toward idle speed position) of an imaginary line through bolt, lever shaft and eye bolt. Hold bolt and tighten lock nut.

2) Start engine and move speed control lever to maximum speed position and release it. Lever should return to idle speed

position. If it does not, reduce booster spring tension. If it does continue to increase spring tension until it does not return to idle, then reduce spring tension until it returns to idle. Tighten lock nuts.

## FUEL PUMP PRESSURE & VOLUME

Pressure..... 45-70 psi  
Volume @ 2500 RPM..... .6 gal.

## ELECTRICAL

### BATTERY

12 Volt - Negative Ground.

| Application | Capacity (Amps) |
|-------------|-----------------|
| 3-53N.....  | 150             |

### STARTER

| Application | Delco Part No. |
|-------------|----------------|
| 3-53N.....  | 1113203        |

Other Data & Specifications - See *Delco Starters* in *ELECTRICAL* Section.

### ALTERNATOR

| Application   | Amps. | Delco Part No. |
|---------------|-------|----------------|
| Standard..... | 42    | 1100696        |
| Optional..... | 61    | 1100750        |
| Optional..... | 62    | 1117782        |

Other Data & Specifications - See *Delco Alternators* in *ELECTRICAL* Section.

### ALTERNATOR REGULATOR

| Application                               | Delco Part No. |
|-------------------------------------------|----------------|
| Standard (Exc. for Alt. No. 1117782)..... | 1119515        |
| Optional (Std. for Alt. No. 1117782)..... | 1116378        |

Other Data & Specifications - See *Delco Alternator Regulators* in *ELECTRICAL* Section.

## ENGINE

### CYLINDER HEAD TIGHTENING

Gradually tighten head bolts to 170-180 ft. lbs. in sequence shown in illustration.

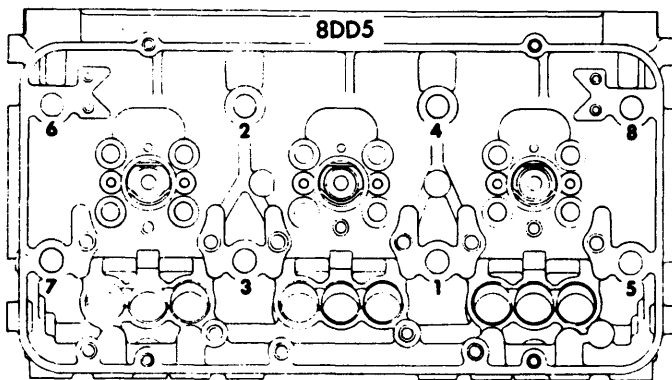

CYLINDER HEAD TIGHTENING SEQUENCE

### BELT ADJUSTMENT

Tension (lbs.) using BT-35-73F Tension Gauge.

| Application                 | Lbs.   |
|-----------------------------|--------|
| Fan Drive.....              | 40-50  |
| Generator Drive             |        |
| Two 3/8" or 1/2" Belts..... | 40-50  |
| One 1/2" Belt.....          | 50-70  |
| Triangular Drives.....      | 90-120 |

### FILTERS & CLEANERS

| Filter or Cleaner                | Service Interval (Miles) |
|----------------------------------|--------------------------|
| Air Cleaner (Dry Type).....      | 20,000-25,000            |
| Air Cleaner (Oil Bath).....      | Clean 6000               |
| Oil Filter.....                  | Replace 4000-6000        |
| Fuel Filter.....                 | Replace 8000-12,000      |
| Air Compressor Air Strainer..... | Clean 4000-6000          |
| Coolant Filter.....              | Replace 20,000-25,000    |

### CAPACITIES

| Application         | Quantity   |
|---------------------|------------|
| Cooling System..... | 22 qts.    |
| Crankcase.....      | ① 10 qts.  |
| Man. Trans.....     | 7 pts.     |
| Rear Axle.....      | ② 6.5 pts. |

① - Add two quarts with filter change.  
② - H110 optional rear axle 14 pts.