

MOTORCRAFT MODEL 2100-D 2-BARREL

AMERICAN MOTORS

American Motors Code

Application	Man. Trans.	Auto. Trans.
304" (All Models)		
Federal.....	4DM2	4DA2
California.....		4DA2E
360" (All Models)		
Federal.....		4RA2
California.....		4RAC2

FORD MOTOR CO.

Ford Carburetor No.

Application	Man. Trans.	Auto. Trans.
302"		
Torino & Montego.....	D4OE-EA,JA.....	①D4OE-GA
Maverick & Comet.....	D4DE-PA	D4DE-RB
Ranchero.....	D4OE-CA	D4DE-LA
351"W		
All Models.....		D4AE-EA,DA
351"C		
All Models.....		D4OE-AA,FA
400"		
All (Exc. Sta. Wag.).....		②D4AE-GA,HB
Station Wagon.....		③D4AE-FA

- ① - Also carb. No. D4DE-NB
 ② - Also carb. No. D4ME-BA,CA.
 ③ - Also carb. No. D4TE-AA.

JEEP

American Motors Code

Application	Man. Trans.	Auto. Trans.
304"		
Federal.....	4DM2	
Calif.	4DMJ2	
360"		
Federal.....	4DM2,4RHD2	4RHD2,4RA2
Calif.	4DMJ2	

CARBURETOR IDENTIFICATION

Ford Motor Co - Carburetor number prefix and suffix (example D3ZF-EA) is stamped on tag attached to carburetor by one air horn screw. First letter of second line on tag ("A" etc.) indicates design changes which may affect parts replacement (other letters on this line are assembly code, designating time of manufacture).

American Motors & Jeep - Carburetor code letters (see listing above and corresponding part number) are stamped on tag attached to carburetor by one bowl cover screw.

DESCRIPTION

Motorcraft 2100-D carburetor has two main assemblies, air horn and main body. Air horn serves as main body cover and contains choke plate and choke diaphragm assembly. Throttle plate, accelerating pump, power valve, and fuel bowl are in main body. Each bore contains main and booster venturis, main fuel discharge accelerating pump discharge, and throttle plate.

Carburetor used on 351"C and 400" engines has unique two-piece fast idle linkage. Crankcase emission hose is incorporated in main body.

Choke Diaphragm Assembly

Fast Idle Cam Adjusting Screw

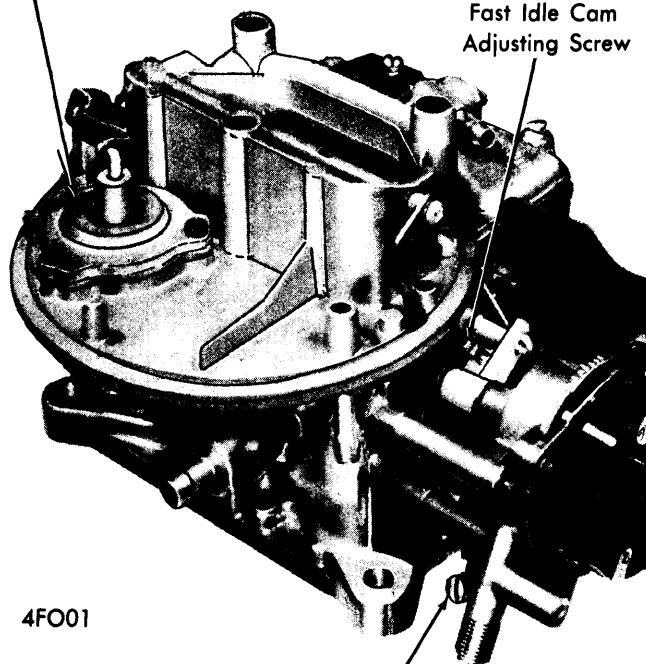

4FO01

Fast Idle Adjusting Screw

MOTORCRAFT 2100-D CARBURETOR ASSEMBLY
(TYPICAL)

ADJUSTMENT

ACCELERATOR PUMP STROKE

Accelerator pump stroke has been preset at factory for each particular engine application. Additional holes are only provided for different engine applications. Check to be sure

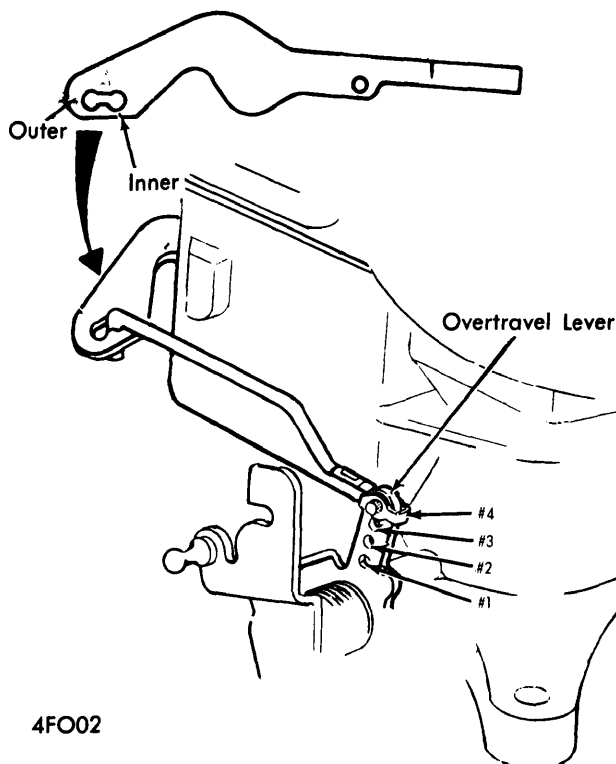

4FO02

ACCELERATOR PUMP STROKE ADJUSTMENT

MOTORCRAFT MODEL 2100-D 2-BARREL (Cont.)

that pump connecting rod is in inner hole, (hole nearest carburetor body) of pump lever. On overtravel lever, connecting rod should be in top position (Ford) and second from top (American Motors).

FLOAT LEVEL (WET SETTING)

With air horn and gasket installed temporarily on carburetor, idle engine for at least three minutes to stabilize fuel level in bowl, then remove air horn and gasket. With engine idling, use "T" scale to measure from top machined surface of bowl to surface of fuel at a point at least 1/4" away from any vertical surface. If fuel level not correct, stop engine and adjust by bending float tab toward or away from inlet needle as required (**CAUTION** - Do not allow float tab to contact needle while making adjustment). Repeat entire procedure to recheck fuel level. After adjustment completed, install air horn and gasket and make necessary carburetor adjustments.

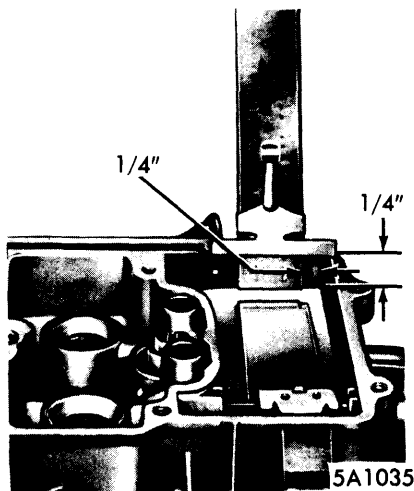

FUEL LEVEL ADJUSTMENT

FLOAT LEVEL (DRY SETTING)

NOTE - Dry float setting is preliminary adjustment only. Final adjustment (wet setting) must be made after carburetor is mounted on vehicle.

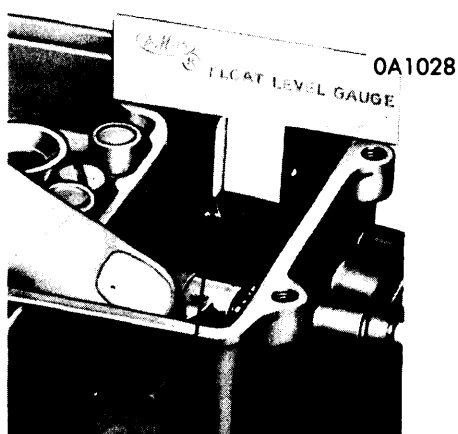

Float Should Just Touch At This Point

DRY FLOAT LEVEL ADJUSTMENT

With air horn removed, depress float tab to seat fuel inlet needle. Measure distance from top of main body (gasket removed) to float, at point 1/8" from free end of toe. If adjustment is necessary, bend float tab. **NOTE** - Do not allow float tab to contact needle while making adjustment as Viton needle tip may be damaged.

INITIAL CHOKE VALVE CLEARANCE (CHOKE VALVE PULL-DOWN)

NOTE - On Ford Motor Co. vehicles, choke valve pull-down is preset at factory by means of air/fuel meter, no specific clearance is indicated for this adjustment. Adjustment should only be performed if there is an over-rich or over-lean condition existing at cold starting.

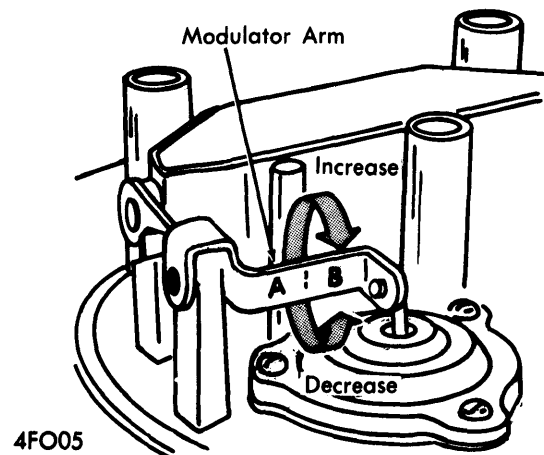

INITIAL CHOKE VALVE CLEARANCE

Ford Motor Co. - With engine at normal operating temperature, loosen choke thermostat housing and set housing to 90° "RICH" (counterclockwise). Turn fast idle adjusting screw out one full turn. Start engine and measure clearance (for reference) between lower edge of choke plate and air horn wall. Adjustment is made with diaphragm stop screw, located on underside of diaphragm housing (underside of air horn).

Over-Rich Condition - Increase clearance .020", by turning diaphragm stop screw. After initial adjustment recheck cold starting condition. If original adjustment is lost, set clearance to .160" and continue with adjustment.

Over-Lean Condition - Decrease clearance .020", by turning diaphragm stop screw. After initial adjustment, recheck cold starting condition. If original adjustment is lost, set clearance to .160" and continue with adjustment.

American Motors & Jeep - Remove choke shield and loosen retaining screws to allow movement of cover. Rotate choke cover 1/4" turn counterclockwise (rich) from index and tighten retaining screws. Disconnect choke heat inlet tube. Align fast idle screw with second step (index) and against shoulder of high step. Start engine without moving accelerator linkage. Turn fast idle cam adjusting screw counterclockwise 3 full turns. Adjust initial choke valve clearance (measured between lower edge of choke valve and air horn wall) to specified setting. Grasp modulator arm securely with pliers and twist arm with second pair of pliers. Twist toward front of carburetor to increase clearance and toward rear of carburetor to decrease clearance. **CAUTION** - Use extreme care while twisting modulator arm to avoid damaging nylon piston

MOTORCRAFT MODEL 2100-D 2-BARREL (Cont.)

rod of modulator assembly. After completing adjustment, stop engine and connect choke heat tube. Turn fast idle cam lever adjusting screw in (clockwise) three full turns. Do not reset choke cover until fast idle cam linkage adjustment has been performed.

FAST IDLE CAM CLEARANCE

NOTE — Fast idle RPM and choke pull-down clearance must be set prior to adjusting fast idle cam clearance.

Ford Motor Co. — 1) With choke cover still at 90° "RICH" position and fast idle speed screw or lever (351" C and 400" have two-piece fast idle lever) on high step of cam; depress choke pull-down diaphragm against its stop screw, to place choke in pull-down position.

2) While holding diaphragm depressed, open throttle slightly and allow fast idle cam to fall. Close throttle and check position of fast idle cam or lever. Screw should contact cam at "V" mark on cam. Adjust fast idle cam adjusting screw to obtain proper setting.

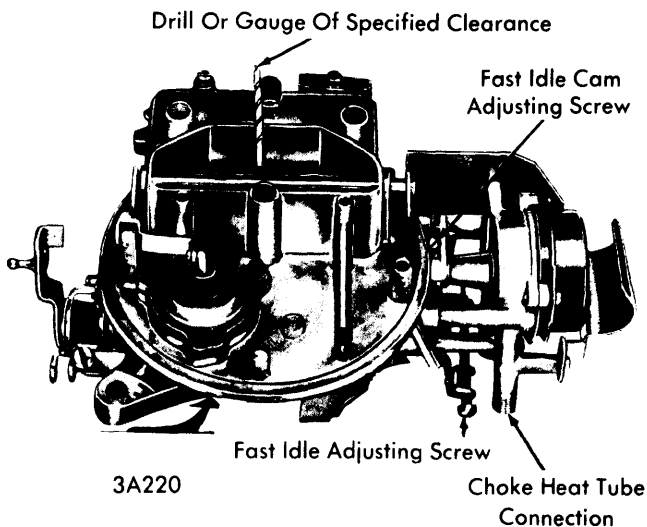

FAST IDLE CAM LINKAGE ADJUSTMENT

CHOKE UNLOADER

American Motors — 1) Hold throttle fully open and apply pressure on the choke valve toward closed position. Measure clearance between lower edge of choke valve and air horn wall. Clearance should be at least .250". Adjust by bending unloader tang which contacts fast idle cam.

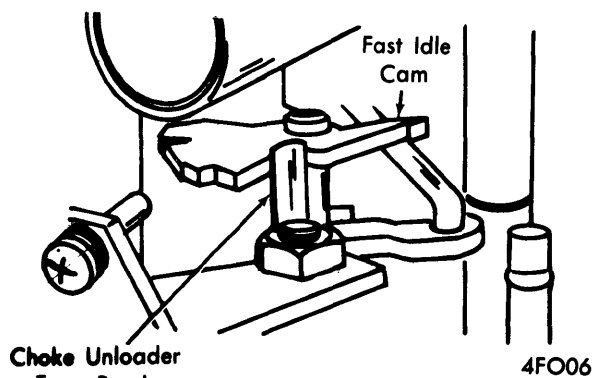

UNLOADER ADJUSTMENT

NOTE — Bend toward fast idle cam to increase clearance and away from cam to decrease clearance. Do not bend unloader tang downward from a horizontal plane.

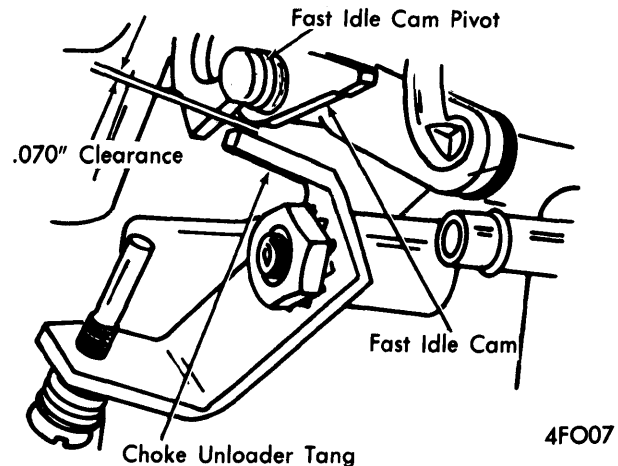

UNLOADER-TO-FAST IDLE CAM CLEARANCE

2) After making adjustment, open throttle until unloader tang is directly below fast idle cam pivot. There must be .070" clearance between unloader tang and edge of fast idle cam. Operate throttle and check unloader tang to make sure that it does not bind, contact or stick on any part of carburetor linkage.

3) After carburetor is installed on vehicle, check that full throttle can be reached, when accelerator pedal is depressed. If it can not be reached, it may be necessary to remove excess padding under floor mat or to reposition throttle cable bracket, located on engine.

AUTOMATIC CHOKE

All Carburetors — Loosen choke cover retaining screws and rotate cover and thermostatic coil assembly in "Rich" or "Lean" direction to align reference mark on cover with correct scale graduation on housing. **NOTE** — "Index" setting is with reference mark on cover aligned with longer center mark on housing.

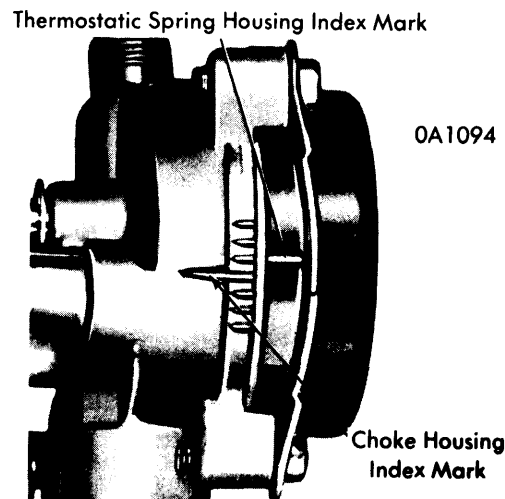

AUTOMATIC CHOKE ADJUSTMENT

MOTORCRAFT MODEL 2100-D 2-BARREL (Cont.)

DASHPOT

All Carburetors (If Equipped) — With throttle valves closed in curb idle position, fully depress dashpot plunger and measure clearance between end of plunger stem and throttle valve lever. If clearance not correct (1/8"), adjust by loosening locknut and turning dashpot in or out of mounting bracket.

Plunger Depressed Adjust To Specified Clearance

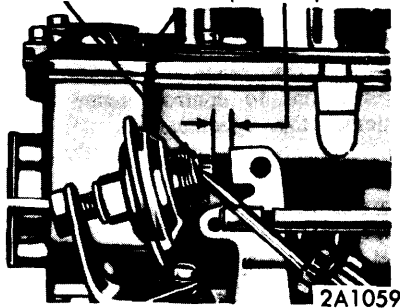

DASHPOT ADJUSTMENT

FAST IDLE SPEED

Ford Motor Co. — With engine at normal operating temperature, curb idle speed and mixture properly set, stop engine and remove air cleaner. Plug vacuum line from intake manifold. Disconnect vacuum hoses at spark port and distributor primary diaphragm. Install jumper hose directly between the two. Disconnect and plug EGR vacuum line. Start engine, and manually rotate fast idle cam until fast idle adjusting screw rests against specified step of cam. Turn fast idle screw to obtain specified RPM.

American Motors & Jeep — Set fast idle speed with engine at normal operating temperature and fast idle screw against index mark (second) step of fast idle cam. Adjust to correct RPM by turning fast idle screw.

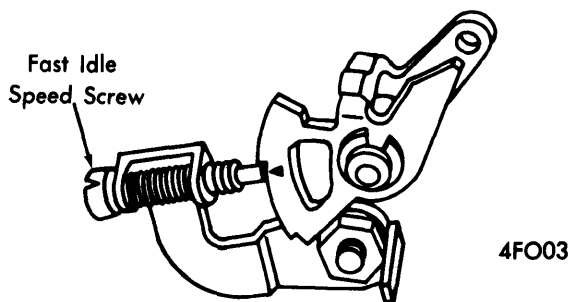

CONVENTIONAL ONE-PIECE FAST IDLE LEVER

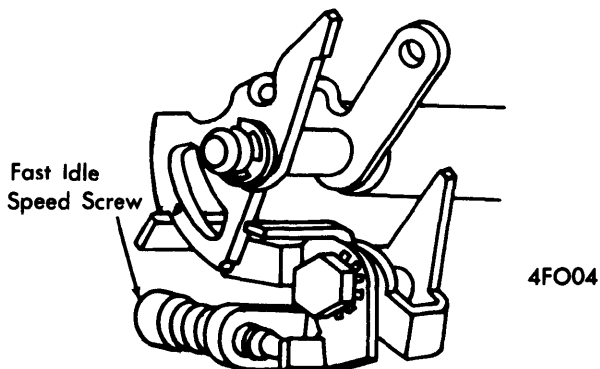

TWO-PIECE FAST IDLE LEVER FOR 351" & 400" ENGINES (FORD ONLY)

IDLE SPEED (THROTTLE STOP) SOLENOID

NOTE — In order to comply with emission standards, specifications shown on engine compartment emission control tune-up decal must be used in all instances. Decal information should be considered the most valid information available. If performing only adjustment procedures, do not remove idle mixture limiter caps.

Preparations For Adjustment (American Motors) — Block wheels and apply parking brake. Start and warm engine to normal operating temperature. Turn off air conditioner and place manual transmission in Neutral or automatic transmission in "D". Verify that dwell and timing are properly set. Leave air cleaner installed. Adjust idle speed 30 RPM above specified idle RPM.

Preparations For Adjustment (Ford Motor Co.) — Block wheels and apply parking brake. Start and warm engine to normal operating temperature. Set timing and idle. Turn mixture screws to full rich stops (counterclockwise). Remove air cleaner, disconnect and plug evaporator canister-to-air cleaner hose.

Adjustment (Ford Motor Co.) — With solenoid energized (if equipped), turn solenoid adjusting screw to obtain specified idle RPM. Place automatic transmission in "N" and disconnect solenoid wire. Adjust carburetor idle speed screw to obtain 500-550 RPM. Reconnect solenoid wire and allow plunger to extend. Stop engine and replace air cleaner and connect all vacuum hoses. Restart engine and readjust solenoid (if equipped) and mixture screws to obtain smoothest possible idle at specified idle RPM.

IDLE SPEED & MIXTURE (EXHAUST GAS ANALYZER PROCEDURE)

NOTE — Do not allow engine to idle more than two minutes at one time. If adjustments take longer, raise engine speed to 2000 RPM to stabilize engine temperature, then continue with adjustment.

American Motors — 1) Preparations for adjustment must be completed. See *Idle Speed (Throttle Stop) Solenoid*. Connect exhaust gas analyzer and adjust idle speed 30 RPM above specified idle RPM. If equipped with solenoid, adjust 30 RPM above specified idle RPM with solenoid energized.

2) Disconnect solenoid and place automatic transmission in "N". Adjust carburetor speed screw to obtain 500 RPM and reconnect solenoid.

3) On all models, if CO level is not within specifications, turn mixture screws in or out $\frac{1}{16}$ turn at a time, until correct CO level is obtained at specified RPM. **NOTE** — Allow ten seconds between each adjustment, for meter stabilization.

4) If idle speed changes more than 30 RPM during adjustments, reset to specified RPM. Repeat adjustments until correct CO level is obtained at specified idle RPM.

Ford Motor Co. — 1) Preparations for adjustment must be completed. See *Idle Speed (Throttle Stop) Solenoid*. Connect exhaust gas analyzer and place automatic transmission in "D" or manual transmission in Neutral. If idle CO level is not within specifications, recheck meter calibration, then recheck idle CO level.

2) If CO level is still not within specifications, remove air cleaner and idle mixture limiter caps. Adjust mixture screws to obtain specified CO level and immediately readjust idle speed to specifications. Install air cleaner and recheck CO level. Repeat adjustment procedure, if necessary, to obtain correct CO level at specified idle RPM. Install new (blue) limiter caps on mixture screw.

MOTORCRAFT MODEL 2100-D 2-BARREL (Cont.)

CARBURETOR ADJUSTMENT SPECIFICATIONS									
Carb. Number	Idle Speed (Engine RPM)		Float Setting		Accelerator Pump Setting		Initial Choke Pull-Down Clearance	Fast Idle Cam Linkage Clearance	Auto. Choke Setting
	Hot	Fast	Wet	Dry	Overtravel Lever	Pump Lever			
American Motors Code									
4DA2	750±50	ⓐ1600	.78"	.40"140"	.130"	1-Rich
4DA2E	750±50	ⓐ1600	.78"	.40"140"	.130"	1-Rich
4DM2	750±50	ⓐ1600	.78"	.40"140"	.130"	1-Rich
4RA2	750±50	ⓐ1600	.78"	.40"140"	.130"	1-Rich
4RAC2	750±50	ⓐ1600	.78"	.40"140"	.130"	1-Rich
Ford Carb. No.									
D4AE-DA	①	1500	1 ³ / ₁₆ "	7 ¹ / ₁₆ "	2	Inner	②	②	1-Rich
D4AE-EA	①	1500	1 ³ / ₁₆ "	7 ¹ / ₁₆ "	2	Inner	②	②	3-Rich
D4AE-FA	①	1500	1 ³ / ₁₆ "	7 ¹ / ₁₆ "	3	Inner	②	②	3-Rich
D4OE-FA	①	1500	1 ³ / ₁₆ "	7 ¹ / ₁₆ "	2	Inner	②	②	3-Rich
D4AE-GA	①	1500	1 ³ / ₁₆ "	7 ¹ / ₁₆ "	3	Inner	②	②	3-Rich
D4AE-HB	①	1500	1 ³ / ₁₆ "	7 ¹ / ₁₆ "	3	Inner	②	②	3-Rich
D4DE-NB	①	1500	1 ³ / ₁₆ "	7 ¹ / ₁₆ "	2	Inner	②	②	3-Rich
D4DE-PA	①	1600	1 ³ / ₁₆ "	7 ¹ / ₁₆ "	2	Inner	②	②	3-Rich
D4OE-CA	①	1500	1 ³ / ₁₆ "	7 ¹ / ₁₆ "	2	Inner	②	②	3-Rich
D4DE-LA	①	1500	1 ³ / ₁₆ "	7 ¹ / ₁₆ "	2	Inner	②	②	3-Rich
D4DE-RB	①	1500	1 ³ / ₁₆ "	7 ¹ / ₁₆ "	2	Inner	②	②	3-Rich
D4ME-BA	①	1500	1 ³ / ₁₆ "	7 ¹ / ₁₆ "	3	Inner	②	②	3-Rich
D4ME-CA	①	1500	1 ³ / ₁₆ "	7 ¹ / ₁₆ "	3	Inner	②	②	3-Rich

① — See engine compartment emission control tune-up decal.

② — See specific adjustment procedure.

IDLE SPEED & MIXTURE (TACHOMETER SPEED DROP PROCEDURE)

American Motors — 1) Preparations for adjustment must be completed. See *Idle Speed (Throttle Stop) Solenoid*. Adjust idle mixture screws to full rich stop and remove idle limiter caps. Adjust idle 30 RPM above specified idle RPM.

2) If equipped with solenoid, leave solenoid energized and adjust solenoid in or out to obtain 30 RPM above specified idle RPM. Disconnect solenoid and place automatic transmission in "N". Adjust carburetor speed screw to obtain 500 RPM, then reconnect solenoid.

3) On all models, turn mixture screws in (lean) until RPM loss is indicated. Turn mixture screws out (richer) until highest RPM is obtained with "lean best idle" condition. **NOTE** — If speed changes more than 30 RPM during mixture adjustment, reset idle speed to 30 RPM above specified idle RPM and repeat adjustment. After obtaining "lean best idle" (within specified idle RPM range), turn mixture screws in (lean) until specified idle RPM drop is obtained (35 RPM on manual transmission or 20 RPM on automatic transmission).

OVERHAUL

DISASSEMBLY

Air Horn — 1) Remove air cleaner anchor screw and automatic choke control rod retainer. Remove air horn attaching screws, lockwashers, carburetor I.D. tag, then remove air horn and gasket. Remove choke control rod by loosening

screw securing choke shaft lever to choke shaft. Remove rod from air horn and slide plastic dust seal out of air horn.

2) Remove choke diaphragm assembly, then if necessary to remove choke plate, remove staking marks on attaching screws and remove screws. Remove choke plate by sliding it out of the shaft from the top of the air horn, then remove shaft from air horn.

Automatic Choke — 1) Remove fast idle cam retainer, thermostatic choke spring housing screws and then remove clamp, housing and gasket.

2) Remove choke housing assembly retaining screws, choke housing assembly, gasket and the fast idle cam rod and cam lever. Remove choke lever retaining screw and washer, then remove choke lever and fast idle cam lever.

Main Body — 1) Pry float shaft retainer from fuel inlet seat with a screwdriver, then remove float, float shaft retainer and fuel inlet needle assembly. Remove retainer and float shaft from float lever.

2) Remove fuel inlet needle, seat, filter screen, and main jets. Remove booster venturi screw (accelerator pump discharge), air distribution plate, booster venturi and gasket. Invert main body and catch accelerating pump discharge weight and ball in hand. Remove accelerator pump operating rod from over-travel lever and retainer by pressing the ends of the retainer together, while at the same time, pressing the rod away from the retainer until it is free, then remove rod and retainer.

MOTORCRAFT MODEL 2100-D 2-BARREL (Cont.)

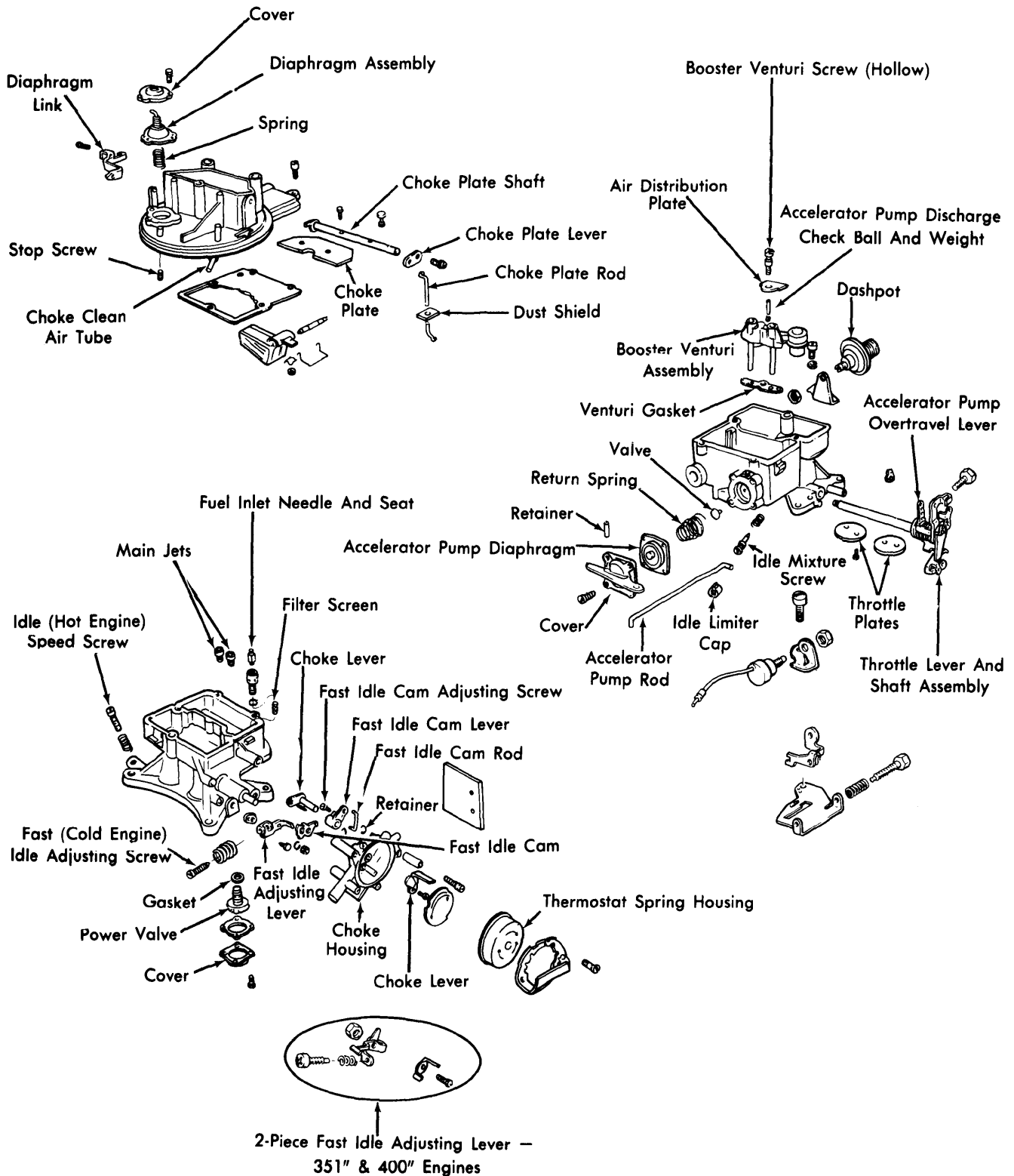

4FO08

MOTORCRAFT 2100-D CARBURETOR ASSEMBLY (TYPICAL)

MOTORCRAFT MODEL 2100-D 2-BARREL (Cont.)

3) Remove accelerating pump cover attaching screws, pump cover, diaphragm assembly and spring. If necessary to remove Elastomer valve, grasp firmly and pull it out; if valve tip broke off during removal, be certain to remove it from fuel bowl. Elastomer valve must always be replaced whenever it has been removed from carburetor.

4) Invert main body and remove power valve cover and gasket then remove valve with a box wrench, along with gasket. Remove idle fuel mixture adjusting needles and springs, then remove limiters from needles. If necessary, remove nut and washer securing fast idle adjusting lever assembly to throttle shaft and remove lever assembly. Remove anti-stall dashpot or solenoid. If necessary to remove throttle plates, scribe throttle plates along shaft and mark each plate and its corresponding bore for re-assembly. Slide throttle shaft from main body.

CLEANING & INSPECTION

Clean all parts, except accelerating pump diaphragm, power valve, secondary operating diaphragm, and anti-stall dashpot, in a suitable solvent. Check all parts for wear, damage, nicks, burrs, or traces of foreign material. Blow out all passages with compressed air. Replace parts as necessary.

REASSEMBLY

Use all new gaskets, reverse disassembly procedure and note the following:

Throttle Valve Installation – Refer to scribed lines and marks made at disassembly and install throttle valves with attaching screws snug (not tight), close valves and check fit by holding assembly up to a light (little or no light should show between valve edges and bore). Tap valves lightly to centralize them, then tighten and stake screws securely while supporting shaft on a metal bar or a block of wood.

Choke Valve Installation – Install choke valve with attaching screws snug (not tight), check valve fit and free movement by moving valve from closed to open position (binding can be corrected by grinding edge of valve), then tighten screws securely while holding valve closed. Stake screws while supporting with a metal bar or block of wood.

Choke Valve Rod & Seal Installation – Assemble choke rod seal between two brass washers and slide them into position on seal retainer, insert choke rod through seal and air horn to engage choke shaft lever clevis nut. *NOTE – Rod is adjusted during "Choke Valve Pull-Down" adjustment.*

Accelerating Pump Elastomer Valve Installation – Lubricate tip of new valve and insert valve tip in center hole in pump cavity, then use needle nosed pliers inserted in fuel bowl to pull valve in until it is fully seated, cut off valve tip at retaining shoulder and remove tip from fuel bowl.

Accelerating Pump Diaphragm Installation – Position return spring on boss in pump chamber, assemble diaphragm and cover and install two cover screws that do not retain

Idle Mixture Screw & Limiter Cap Installation – Install idle mixture needles and springs. Turn screws in until lightly seated, then back out 1½ turns (Ford Motor Co.), 2 turns (American Motors & Jeep), for an initial adjustment. *NOTE – Idle limiter caps should not be installed until final idle mixture adjustment is made.*

Power Valve Cover Installation – Use new gasket and position cover so that limiter stops are in position to provide positive stops for tabs on idle mixture screw limiter caps.