

ROCHESTER 4MC & 4MV 4-BARREL

ROCHESTER 4MC

OLDSMOBILE

Rochester Carb. No.

	Man Trans.	Auto. Trans.
350" Omega	7043255	7043255
350" Cutlass	7043257	7043250
350" Vista Cruiser	7043257	7043256
455" Cutlass	7043253	7043251
455" 88 & 98		7043251
455" Toronado		7043252

PONTIAC

400"	7043263	7043264, 7043274
455"	7043265	7043262, 7043272
455" S.D.	7043273	7043270

ROCHESTER 4MV

BUICK

350"	7043245	7043244
455"	7043243	7043240
455" Stage I	7043242	7043242

CADILLAC

Standard		7047331
Eldorado		7047332

CHEVROLET

350"	7043203	7043202
350" ①	7043213	7043212
454"	7043201	7043200

① — Z-28 & Corvette with 9.0:1 compression ratio.

CARBURETOR IDENTIFICATION

Carburetor part number is stamped on a verticle section of the float bowl, near secondary throttle lever. When replacing float bowl assembly, follow manufacturers instructions, contained in service package, so that the part number is transferred to the new float bowl.

CARBURETOR DESCRIPTION

The 4MC and 4MV carburetors are 4-barrel downdraft types; having one very basic difference that allows easy identification. The 4MC models are equipped with an integral automatic choke, whereas the 4MV model utilizes a remote thermostatic coil, mounted on the exhaust manifold, which operates the conventional choke valve in carburetor air horn. The 1973 models are of the same basic design as previous models with the following design changes and improvements:

Buick — The 4MV carburetor has been completely recalibrated to meet current engine and emission requirements. Models for 350 V-8 engines have a pull-over enrichment circuit to provide extra needed fuel at higher speeds for good performance. The secondary (rear) vacuum break unit is changed to provide a longer delay in choke opening time, to prevent stalling after initial start and during warm-up period. Also, a secondary vacuum clean air purge system is incorporated to extract fuel vapors and dirt drawn into the bleed check valve.

Cadillac — The idle limiter caps, once removed, should not be replaced. Verticle and horizontal ports, located in carburetor throttle body, are used to provide vacuum signal for positioning the EGR valve in relation to amount of primary throttle valve opening, thus metering exhaust gases to intake manifold. The pull-over enrichment (POE) system, introduced as a late change in 1972, is standard. It is used to reduce vacuum signal at secondary nozzles, causing air to by-pass the air valve for leaner air/fuel mixture. This improves throttle response at higher altitudes and in hot weather.

Chevrolet — A recalibration of the 4MV carburetor has been made to assist in meeting emission requirements. The choke rod has been moved to the highest step of fast idle cam to improve engine choke operations during warm-up. The EGR system adds dual punched ports in carburetor throttle body to supply vacuum signal for operation of EGR valve.

Oldsmobile — Dual punched ports to provide for the addition of EGR system. These ports allow timed vacuum signals to operate the EGR valve.

Pontiac — The use of a recalibrated 4MC carburetor (previous models used 4MV) assists in meeting exhaust emission requirements. Models used on 455 CID high performance option have a triple venturi set-up in primary bores for improved metering control. The integral choke assembly requires new adjustment procedures and ports; one just above the throttle valve and other between throttle valve and throttle body casting. A timed vacuum signal is provided through these ports for operation of the EGR valve.

ADJUSTMENT

IDLE SPEED & MIXTURE

► **NOTE** — Carburetors have plastic idle limiter caps on idle mixture adjusting screws. No attempt to adjust idle mixture screws should be made. If caps are removed during such operations as carburetor overhaul, fuel bowl replacement, or throttle body replacement, special procedure is required to readjust idle mixture screws. See "General Motors Tune-Up" in Exhaust Emission Manual.

Buick — Make adjustment with engine at normal operating temperature, air cleaner installed, choke open, and air conditioning OFF. Disconnect hose from air cleaner to vapor canister. Disconnect and plug distributor vacuum advance hose. Open throttle momentarily to permit idle solenoid to extend and contact throttle lever pad in idle position. Adjust solenoid set screw to obtain higher specified RPM. **NOTE** — Solenoid mounting bracket may be moved for additional adjustment. Disconnect solenoid wire and adjust idle screw to obtain lower specified RPM, then reconnect wire and hoses.

Cadillac — With engine at normal operating temperature, disconnect and plug distributor vacuum advance hose at distributor. Disconnect and plug parking brake hose and proceed as follows: Remove air cleaner (do not disconnect vacuum hoses). Disconnect and plug air leveling compressor hose at air cleaner. Connect tachometer and place transmission selector in "N". Back mixture screws out six turns each. Place transmission in "D" and check that air conditioning is OFF. Disconnect wire at anti-dieseling solenoid (plunger should retract fully). Adjust idle speed screw to 350-400 RPM. Reconnect wire and crack throttle slightly to extend solenoid plunger. Turn solenoid body to set 640 RPM. Lock solenoid in place and alternately turn each mixture screw inward 1/4 turn

ROCHESTER 4MC & 4MV 4-BARREL (Cont.)

at a time until specified 600 RPM is reached. Back each screw out 1/4 turn and readjust solenoid to give idle speed of 600 RPM. Lock solenoid in place. Reconnect hoses and install air cleaner.

Chevrolet — Make adjustment with engine at normal operating temperature, air cleaner installed, choke open, and air conditioning OFF. Set parking brake and block drive wheels. Disconnect fuel tank vapor canister hose, then disconnect distributor vacuum hose at distributor and plug. Disconnect electrical connection at idle stop solenoid and adjust idle speed screw to the lower specified RPM. Check dwell, timing and low idle speed. Reconnect solenoid connector, open throttle momentarily and adjust solenoid plunger screw to obtain higher specified RPM.

Oldsmobile — Make adjustment with engine at normal operating temperature, air cleaner removed, air cleaner vacuum hose disconnected at intake manifold (and plugged),

and air conditioning OFF. Set parking brake and block drive wheels. Disconnect and plug distributor vacuum hose. Disconnect carburetor hose from vapor canister. With dwell and timing properly adjusted, adjust idle stop solenoid or vacuum actuator (as equipped) to obtain higher specified RPM. Disconnect solenoid or actuator vacuum hose (plug hose) and adjust idle speed screw to lower specified RPM. Make adjustment with transmission in "D".

Pontiac — Adjustments are to be made with engine at normal operating temperature, choke open, air conditioning OFF and carburetor hose removed from vapor canister. Disconnect and plug distributor vacuum hose and EGR valve hoses. Disconnect throttle solenoid wire (idle stop solenoid, if equipped). Set dwell and timing (in that order) to lower specified RPM. Reconnect solenoid wire and manually extend solenoid screw and adjust to higher specified RPM.

CARBURETOR ADJUSTMENT SPECIFICATIONS — #1

Rochester Carb. No.	Slow Curb Idle Speed (Engine RPM) ① ④		Fast Idle Speed (Engine RPM)	Float Level Setting	Accelerator Pump		Air Valve Dashpot Setting
	Man. Trans.	Auto. Trans.			Rod Location	Adjustment	
7043200	600/500	1500 ③	1/4"	INNER	13/32"
7043201	900/500	1350 ③	1/4"	INNER	13/32"
7043202	600/500	1500 ③	7/32"	INNER	13/32"
7043203	900/500	1350 ③	7/32"	INNER	13/32"
7043212	700	1500 ③	7/32"	INNER	13/32"
7043213	900/500	1350 ③	7/32"	INNER	13/32"
7043240	650/500	700 ④	13/32"	INNER	7/16"	.015"
7043242	650/500	700 ④	13/32"	INNER	7/16"	.015"
7043243	900/600	920 ④	13/32"	INNER	7/16"	.015"
7043244	650/500	700 ④	15/32"	OUTER	.306"	.015"
7043245	800/600	820 ④	15/32"	INNER	.41"	.015"
7043250	650/550	1000	1/4"	INNER	3/8"	.050"
7043251	650/550	1000	1/4"	INNER	3/8"	.050"
7043252	650/550	1000	1/4"	INNER	3/8"	.050"
7043253	1000/750	1100	1/4"	INNER	3/8"	.050"
7043255	1100/650	650/550	1100	1/4"	INNER	3/8"	.050"
7043256	650/550	1000	1/4"	INNER	3/8"	.050"
7043257	1100/650	1500	1/4"	INNER	3/8"	.050"
7043262	650	1500 ④	13/32"	INNER	13/32"	.025"
7043263	1000/600	1200 ④	13/32"	INNER	13/32"	.025"
7043264	650	1500 ④	13/32"	INNER	13/32"	.025"
7043265	1000	1500 ④	13/32"	INNER	13/32"	.025"
7043270	750/500	1500 ④
7043272	650	1500 ④	13/32"	INNER	13/32"	.025"
7043273	1000	1500 ④
7043274	650	1500 ④	13/32"	INNER	13/32"	.025"
7047331	600/400	1900-1950 ④	1/4"	OUTER	11/32"	.030"
7047332	600/400	1900-1950 ④	23/64"	OUTER	11/32"	.030"

① — Man. Trans. in "N", Auto. Trans. in "D".

④ — Higher RPM — Solenoid energized.
Lower RPM — Solenoid de-energized.

③ — Cam follower on highest step of cam.

④ — Cam follower on low step of cam.

ROCHESTER 4MC & 4MV 4-BARREL (Cont.)

CARBURETOR ADJUSTMENT SPECIFICATIONS - #2						
Rochester Carb. No.	Choke Rod Or Lever Setting	Secondary Metering Rod	Vacuum Break Setting	Unloader Setting	Air Valve Lockout	Choke Coil Or Rod Setting
7043200	.430"250"	.450"	②
7043201	.430"250"	.450"	②
7043202	.430"250"	.450"	②
7043203	.430"250"	.450"	②
7043212	.430"250"	.450"	②
7043213	.430"250"	.450"	②
7043240	.130"	53/64"	.215"	.335"	②
7043242	.130"	53/64"	.200"	.335"	②
7043243	.130"	53/64"	.215"	.335"	②
7043244	.130"	53/64"	.170"	.335"	②
7043245	.130"	53/64"	.170"	.335"	②
7043250	.230"	.070"	.200"	.300"	.035"	INDEX ②
7043251	.230"	.070"	.200"	.300"	.035"	INDEX ②
7043252	.230"	.070"	.200"	.300"	.035"	1-RICH ②
7043253	.230"	.070"	.275"	.300"	.035"	INDEX ②
7043255	.230"	.070"	.200"	.300"	.035"	INDEX ②
7043256	.230"	.070"	.200"	.300"	.035"	INDEX ②
7043257	.230"	.070"	.200"	.300"	.035"	INDEX ②
7043262	.205"260"	.310"	.015"	INDEX ②
7043263	.205"290"	.310"	.015"	INDEX ②
7043264	.205"260"	.310"	.015"	INDEX ②
7043265	.205"290"	.310"	.015"	INDEX ②
7043270
7043272	.205"290"	.310"	.015"	INDEX ②
7043273
7043274	.205"290"	.310"	.015"	INDEX ②
7047331	.090"	.840"	.200"	.310"	.015"	INDEX ②
7047332	.090"	.840"	.205"	.310"	.015"	INDEX ②

② — See text for adjustment.

FAST IDLE SPEED

Fast idle speed may be adjusted after curb idle speed adjustment has been correctly made. All pre-adjustment conditions apply except for mode of automatic transmission operation. Adjust fast idle speed screw to obtain specified fast idle RPM, with cam follower on correct step of fast idle cam.

Application	Transmission Mode	Cam Step
Buick	"D"	Low
Cadillac	"N"	Highest
Chevrolet	"N"	Highest
Oldsmobile	"N"	Low
Pontiac	①	Highest

① — Varies as per application, check tune-up sticker.

FLOAT LEVEL

Hold retaining pin firmly in place with tang of float lightly seated on float needle. With adjustable T-scale, measure from top of float bowl gasket surface (gasket removed) to top of float at toe. Locate gauge point 1/16" from radius of toe. Bend float up or down to obtain specified clearance.

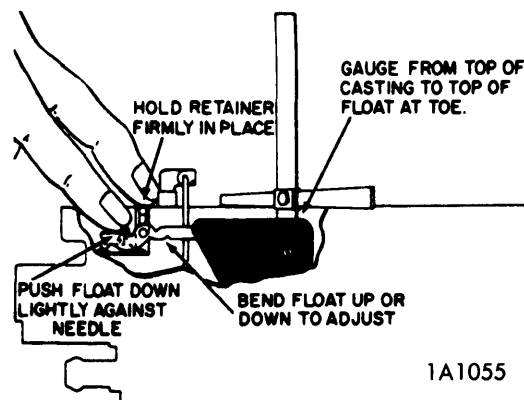

FLOAT LEVEL ADJUSTMENT

ACCELERATOR PUMP ROD

Completely close primary throttle valves by backing out idle speed screw and making sure that fast idle cam follower clears fast idle cam. It will also be necessary to bend the secondary throttle closing tang away from the primary throttle lever.

ROCHESTER 4MC & 4MV 4-BARREL (Cont.)

With pump rod in specified hole, measure distance from top of choke valve wall, next to vent stack, to top of pump stem. Obtain specified measurement by bending pump lever. Support pump lever with screwdriver placed between lever and top of air horn. After adjustment is completed, readjust secondary throttle closing tang and idle speed screw.

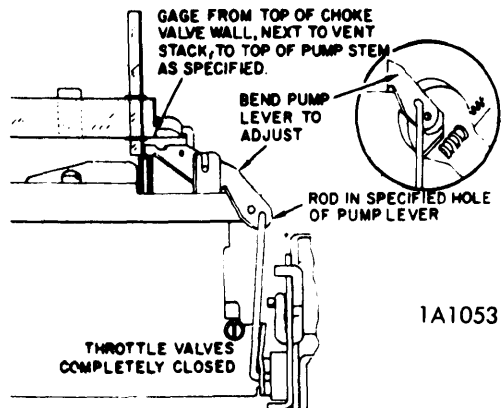

ACCELERATOR PUMP ADJUSTMENT

CHOKE ROD (All 4MV CARBS.)

Place fast idle cam follower on second step of fast idle cam and hold it against high step of cam by pressing lightly upward on vacuum break lever. With choke rod in bottom of slot in choke lever, measure clearance between lower edge of choke valve at choke lever end and air horn wall. If clearance is not as specified, adjust by bending choke rod at existing bend near upper end of rod.

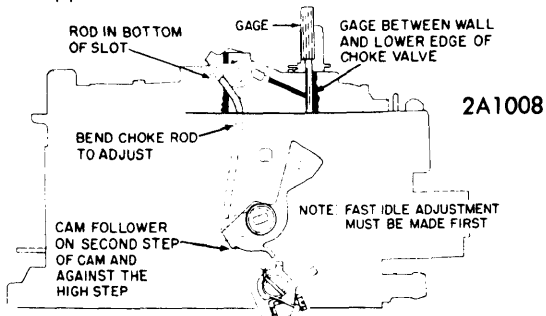

CHOKE ROD ADJUSTMENT (4MV CARBS.)

CHOKE COIL LEVER (4MC CARBS.)

Remove thermostatic choke cover and coil assembly. Hold choke valve closed, push up on thermostatic coil tang to end of travel.

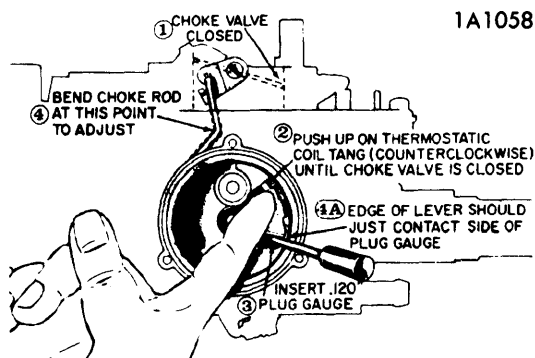

CHOKE COIL LEVER ADJUSTMENT (4MC CARBS.)

travel. Insert a .120" plug gauge in hole in housing, just below edge of lever. Lever should just touch edge of gauge. Bend rod at existing bend if adjustment is required.

CHOKE ROD (FAST IDLE CAM) (4MC CARBS.)

Place fast idle cam follower on second step of fast idle cam, move choke valve toward closed position by pressing on choke coil lever within automatic choke housing (remove choke cover and coil assembly for access) so that cam follower is held firmly against shoulder of high step of cam. With choke valve in this position, measure clearance between lower edge of choke valve at choke lever end and air horn wall. If clearance not correct (see Specifications), adjust by bending tang at side of fast idle cam as shown in illustration.

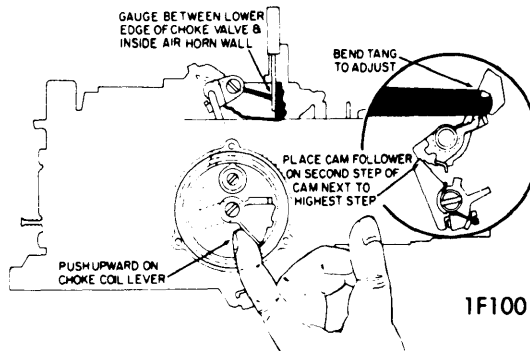

FAST IDLE CAM ADJUSTMENT (4MC CARBS.)

AUTOMATIC CHOKE COIL ROD (ALL 4MV CARBS.)

Buick — Hold choke valve fully closed by rotating vacuum break lever counterclockwise. Pull upward on choke thermostatic coil rod to end of travel. Rod should fit freely in gauging notch at edge of lever. Adjust by bending rod at existing bend. Reconnect rod in "Std" hole in lever.

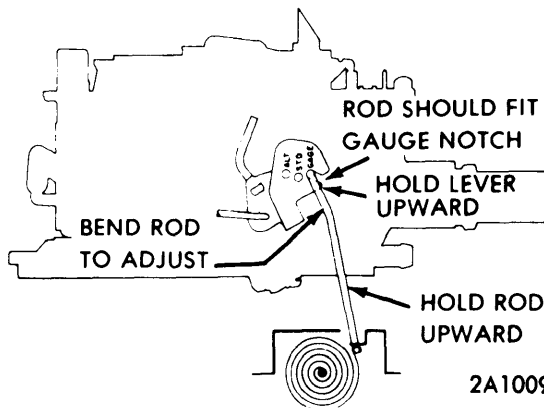

CHOKE COIL ROD ADJUSTMENT (BUICK)

Cadillac — Remove choke assembly from manifold to disengage choke coil rod from vacuum break lever. Reinstall choke coil assembly, but do not install choke coil rod into hole in vacuum break lever. With choke valve completely closed, fast idle cam in cold start position and vacuum break lever in maximum upward position, pull choke coil rod upward to end of travel against stop in choke coil housing. Upper end of rod

ROCHESTER 4MC & 4MV 4-BARREL (Cont.)

should fit in gauging notch. Bend choke coil rod to adjust for proper positioning in specified notch. **NOTE** — "L" gauging notch is for a one notch leaner setting and the "R" notch is for a one notch richer setting.

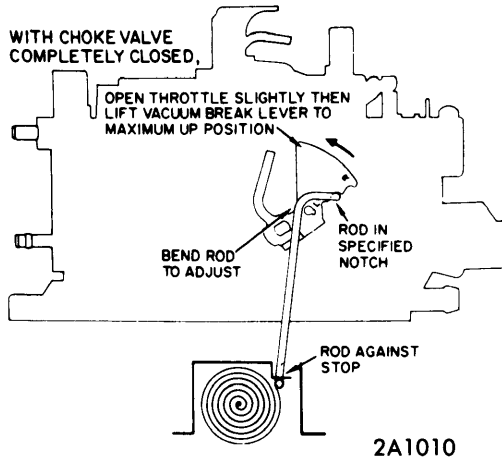

CHOKE COIL ROD ADJUSTMENT (CADILLAC)

Chevrolet — Hold choke valve completely closed by rotating vacuum break lever counterclockwise. With thermostatic coil rod disconnected, push downward on coil rod to end of travel. Rod should contact bracket surface. Coil rod should just fit in adjustment notch in choke coil lever; to adjust, bend choke coil rod or lever.

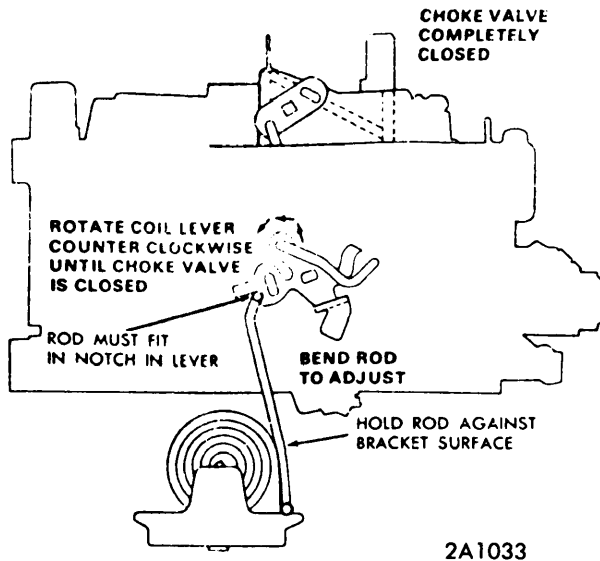

CHOKE COIL ROD ADJUSTMENT (CHEVROLET)

AUTOMATIC CHOKE COIL (4MC CARBS.)

Place cam follower on highest step of cam. Rotate choke cover counterclockwise until choke valve just closes. Rotate choke cover to place index mark at specified setting.

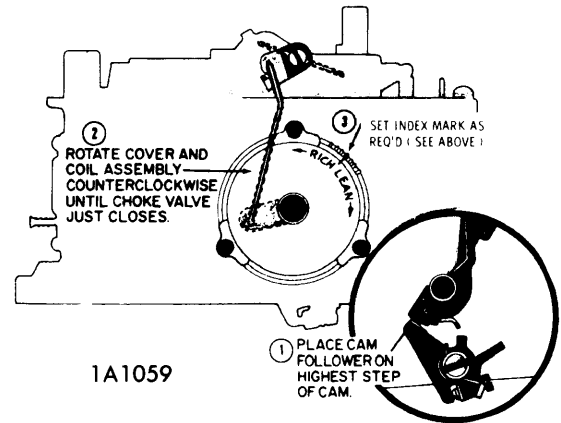

CHOKE COIL ADJUSTMENT (4MC CARBS.)

AIR VALVE DASHPOT (4MV & 4MC CARBS.)

Seat vacuum break diaphragm using an outside vacuum source. Make sure air valves are completely closed. Measure clearance between dashpot rod and end of slot in air valve lever. To adjust, bend rod at air valve end.

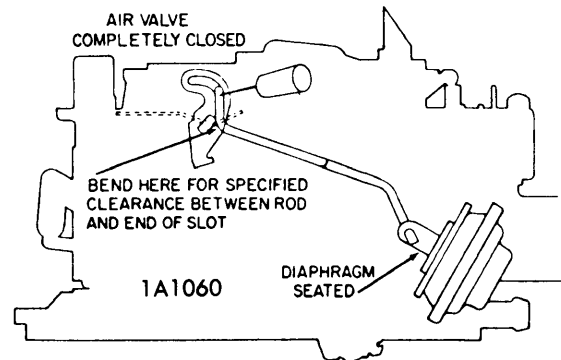

AIR VALVE DASHPOT ADJUSTMENT (4MV & 4MC CARBS.)

AIR VALVE SPRING

To adjust air valve spring wind-up, loosen lockscrew (Allen screw) and turn adjusting screw counterclockwise to remove all spring tension. With air valve held closed, turn adjusting screw

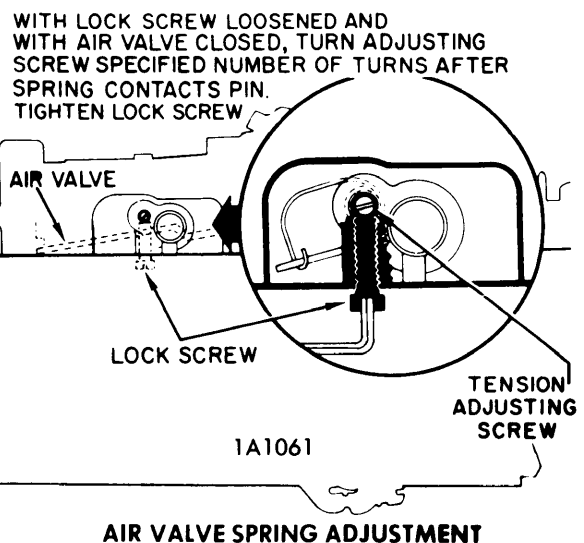

AIR VALVE SPRING ADJUSTMENT

ROCHESTER 4MC & 4MV 4-BARREL (Cont.)

clockwise until torsion spring just contacts pin in shaft; then turn adjusting screw clockwise as specified in following table. While holding adjusting screw in this position, tighten lock screw.

Application	Amount of Turn
Buick	
455"	7/16
350"	11/16
Cadillac	
Except Eldorado	5/16
Eldorado	3/8
Chevrolet	
350"	1/2
350" ①	3/4
454"	11/16
Oldsmobile	
350"	1/2
455"	3/4
Pontiac	
7043263	5/8
7043264	1/2
7043274	9/16
7043262	3/8
7043265	9/16
7043272	3/8

① - Z-28 & Corvette with 9.0:1 compression ratio.

VACUUM BREAK (4MV CARBS.)

Buick - Using an outside vacuum source, seat vacuum break actuator, then with diaphragm seated and vacuum break lever tang held lightly against vacuum break rod, measure distance between lower edge of choke valve and air horn. To adjust, bend tang on lever.

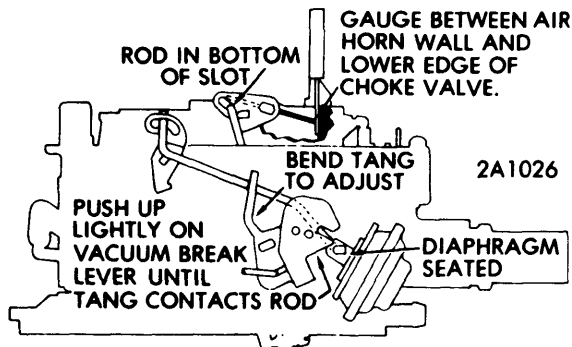

VACUUM BREAK ADJUSTMENT (BUICK)

Cadillac - Open throttle valve and place fast idle cam follower on high step. Place a rubber band on the vacuum break lever and some portion of the air horn near the secondary valve so tang of vacuum break lever will pull rearward, contacting the vacuum break rod when vacuum is applied to unit. Disconnect the rubber tee from vacuum break unit, connect a short 15-20" piece of rubber hose to the nipple of the unit and apply vacuum from an external source to the nipple of the vacuum break unit until the diaphragm is seated and the diaphragm link is in the extended position. Clamp off hose and measure distance between the front wall of air horn and lower edge of choke valve (see Specifications). Remove all play from choke valve by lightly pressing valve toward its open position. NOTE - Choke rod should be at the bottom of the choke lever. Bend vacuum break lever tang to adjust.

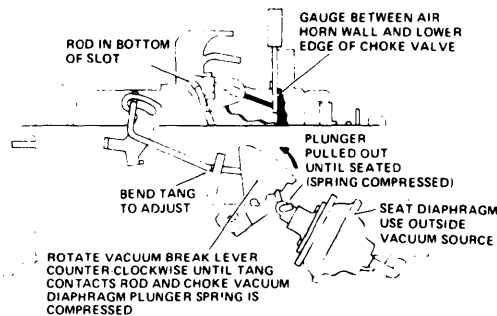

2A1027

VACUUM BREAK ADJUSTMENT (CADILLAC)

Chevrolet - Seat choke vacuum break diaphragm using an outside vacuum source. Open throttle valve slightly so cam follower will clear steps of fast idle cam. Rotate vacuum break lever counterclockwise (towards direction of closed choke) and hold in place with a rubber band. End of vacuum break rod should also be in outer end of slot in vacuum break diaphragm plunger. Measure distance between lower edge of choke valve and inside air horn wall. To adjust, bend vacuum break link.

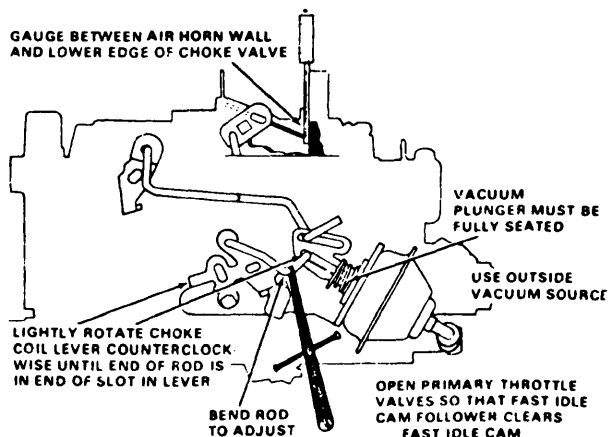

2A1028

VACUUM BREAK ADJUSTMENT (CHEVROLET)

AUXILIARY VACUUM BREAK (4MV CARBS.)

Buick - A bleed hole is located beneath rubber covered filter in vacuum break tube. When seating secondary vacuum break diaphragm, first remove rubber covered filter and plug bleed hole with piece of tape. Use an outside source to seat diaphragm. Rotate choke valve towards closed choke position, pushing on vacuum break lever until spring loaded plunger is fully extended. With choke valve in this position, measure

ROCHESTER 4MC & 4MV 4-BARREL (Cont.)

distance between lower edge of choke valve and inside air horn wall. Bend vacuum break link at U-bend to adjust. Remove tape and reinstall rubber covered filter.

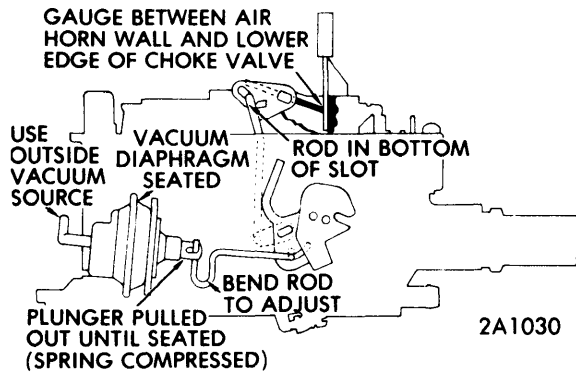

AUXILIARY VACUUM BREAK ADJUSTMENT (BUICK)

VACUUM BREAK (4MC CARBS.)

Place fast idle cam follower on highest step of fast idle cam, use outside vacuum source. *NOTE* — Diaphragm will not seat immediately due to built-in delay action. With choke coil assembly removed, press up on inner choke coil lever to rotate shaft and outer lever counterclockwise until tang on outer lever contacts vacuum break rod. Tap lower edge of choke valve down to take up slack in linkage, then check clearance between lower edge of valve and air horn wall. Clearance should be as specified. To adjust, bend lower end of vacuum break rod at outer lever tang as required.

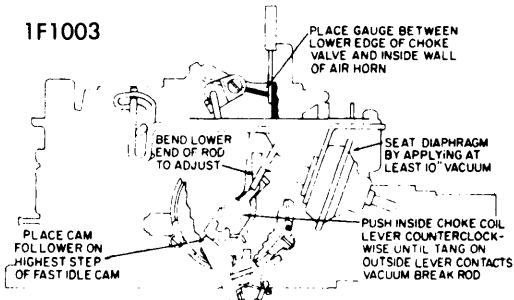

VACUUM BREAK ADJUSTMENT (4MC CARBS.)

UNLOADER

Rotate vacuum break lever counterclockwise towards closed choke position, then open primary throttle to wide open

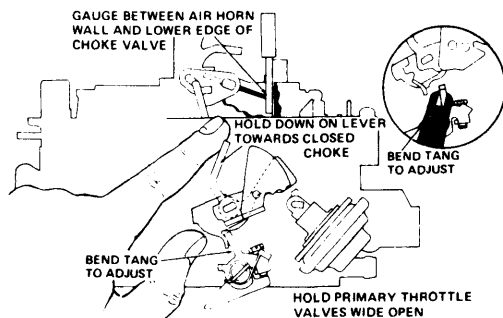

2A1031 UNLOADER ADJUSTMENT

position. With throttle valves held wide open, distance between lower edge of choke valve and air horn wall should be as specified. To adjust, bend tang on fast idle lever.

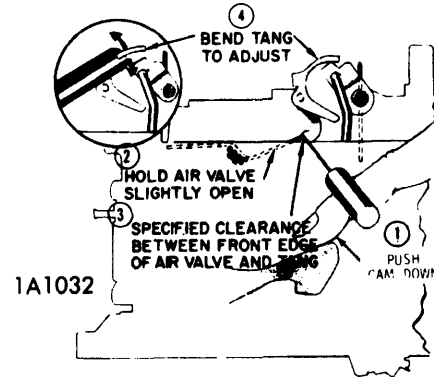

AIR VALVE ADJUSTMENT (4MC CARBS.)

AIR VALVE LOCKOUT (4MC CARBS.)

Push cam down, hold choke valve wide open and air valve slightly open. Measure distance between front edge of air valve and tang on lockout lever. If clearance is not as specified, adjust by bending upper end of lockout lever that bears against choke valve lever.

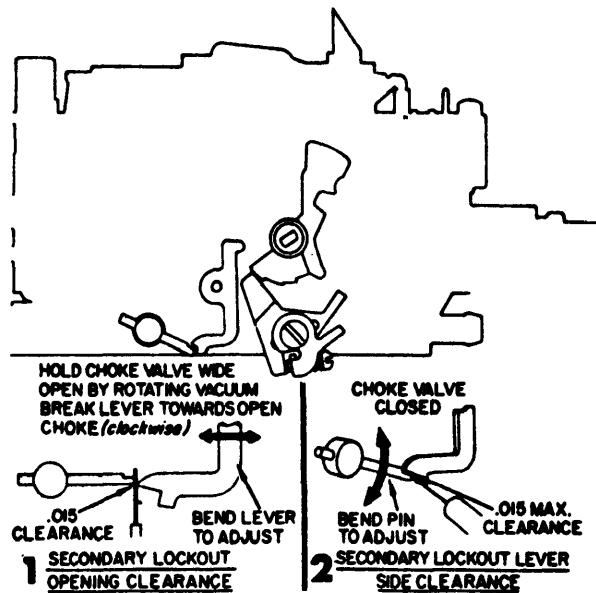

1A1066

SECONDARY THROTTLE LOCKOUT ADJUSTMENT

SECONDARY THROTTLE LOCKOUT

Opening Clearance — Hold choke valve wide open by rotating vacuum break lever toward open choke (clockwise). With secondary throttle valves held partially open, measure clearance between end of lockout pin and toe of lockout lever, distance should be .015". Bend lockout lever to adjust.

ROCHESTER 4MC & 4MV 4-BARREL (Cont.)

Secondary Lockout Pin Side Clearance — With choke valve and secondary throttle valve fully closed, bend lockout pin at point shown to obtain side clearance of .015" between side of lockout pin and lockout lever.

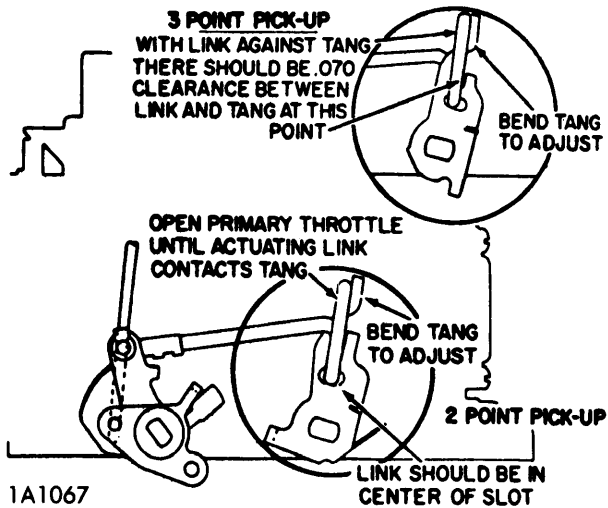

1A1067

SECONDARY THROTTLE CLOSING ADJUSTMENT**SECONDARY THROTTLE OPENING**

Open primary throttle valves until actuating link contacts upper tang on secondary lever. Since there are two types of linkage in production, check as follows:

2-Point Pickup Linkage — Bottom of link should be in center of secondary lever slot.

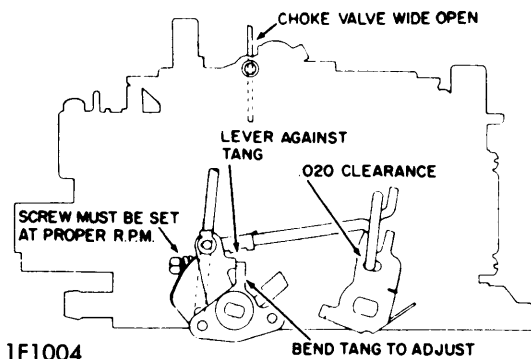

1F1004

SECONDARY CLOSING ADJUSTMENT

3-Point Pickup Linkage — Clearance between link and middle tang should be .070"

SECONDARY CLOSING

With curb idle properly adjusted, cam follower off fast idle cam and choke valve wide open, clearance between secondary throttle actuating rod and front of slot in secondary throttle lever (with closing tang on throttle lever resting against actuating lever) should be .020". If adjustment is required, bend tang on primary throttle actuating lever.

SECONDARY METERING RODS

NOTE — Metering rod hangers are selectively matched to each carburetor and letter stamped. Unless hanger has been damaged, no change in hanger (metering rod) setting will be necessary.

If a new metering rod hanger is installed, adjustment may be checked by measuring distance from top of metering rod to top of air horn (next to air cleaner stud hole). If measurement is not as specified, bend metering rod hanger so that both metering rods are adjusted to the same dimension. **NOTE** — Air valve must be closed when measurement is taken.

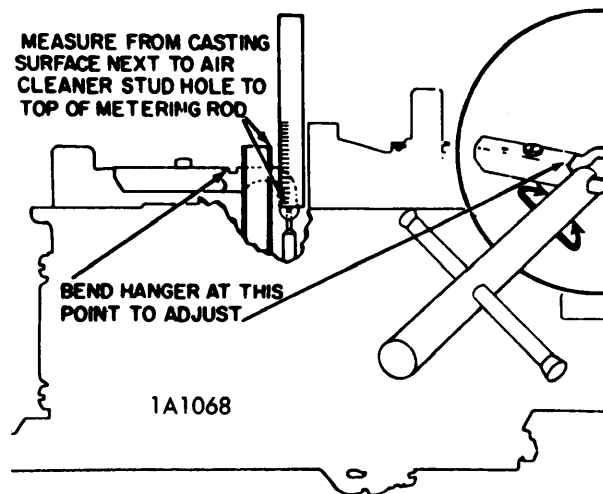

1A1068

SECONDARY METERING ROD ADJUSTMENT

ROCHESTER 4MC & 4MV 4-BARREL (Cont.)

OVERHAUL

Disassembly

Air Horn - 1) Remove idle vent valve assembly. Disconnect choke rod from upper choke shaft lever and pump rod from pump lever. Remove vacuum break rod.

2) Remove air horn-to-bowl attaching screws (2) next to primary venturi. Remove air horn by lifting straight up. Air horn gasket should remain on bowl. **CAUTION** - Be careful not to bend the two small main well air bleed tubes pressed into the air horn. **DO NOT** attempt to remove these tubes.

3) Hold air valve wide open, then tilt and slide secondary metering rods from hanger. **NOTE** - Further disassembly of air horn is not required for cleaning only. For parts replacement, take out choke valve screws, remove choke valve and slide choke shaft out. Remove pump lever roll pin and remove pump lever. **CAUTION** - Air valves and shaft are calibrated and must not be removed. If damaged, replace air horn assembly.

Float Bowl - 1) Remove pump plunger. Remove air horn gasket from dowels on secondary side, then remove gasket from around power piston and primary metering rods. Remove pump return spring, plastic filler over float valve, and power piston and main metering rods (use needle-nose pliers and pull straight up on metering rod hanger directly over power piston).

2) Remove power piston spring, disconnect tension spring from top of each metering rod, and remove rods from hanger. Remove float assembly by sliding assembly toward front of bowl to disengage needle pull clip. Be careful not to distort pull clip. Remove float needle retainer and needle assembly.

3) Remove primary metering jets. **CAUTION** - Do not remove secondary metering discs. Remove pump discharge check ball retainer and check ball, and remove baffle from secondary side of bowl. On 4MV carburetors, remove vacuum hose from tube connection on bowl and from vacuum break assembly. Remove choke assembly from float bowl (**NOTE** - If further disassembly of choke is necessary, remove vacuum brake link. Spread retaining ears on bracket next to vacuum break assembly and remove assembly from the lever).

4) Remove fast idle cam from choke assembly. Remove lower choke rod and actuating lever from inside the float bowl well. Remove hot idle compensator and "O" ring from float bowl.

5) Remove fuel filter and spring. Remove throttle body-to-bowl screws (2) and remove throttle body and insulator gasket.

Automatic Choke Disassembly (4MC Carb.) - 1) Pull cover and coil assembly straight out and off choke housing. Do not attempt to remove baffle plate beneath thermostatic coil. Remove retaining screw and washer inside choke housing, slide complete choke assembly off float bowl.

2) Remove coil lever retaining screw from end of shaft inside choke housing, remove lever from intermediate choke shaft flats, then remove intermediate choke shaft by sliding it out of housing, remove fast idle cam from shaft.

3) Remove cup seal from inside choke housing shaft hole in housing before immersing housing in carburetor cleaner, remove cup seal from float bowl plastic insert before cleaning bowl. **CAUTION** - Do not remove plastic insert.

Throttle Body - Remove pump rod from throttle lever. Remove idle limiter caps, idle mixture screws and springs. **CAUTION** - Handle throttle body carefully so as not to damage secondary throttle valves. Further disassembly for cleaning purposes is not necessary.

Cleaning & Inspection

1) No rubber parts, plastic parts, diaphragms or pump plungers should be immersed in carburetor cleaner. However, the plastic cam on the air valve shaft may be cleaned normally in carburetor cleaner.

2) If air valve or cam are damaged, or air valve is binding, air horn assembly must be replaced. After cleaning parts in a suitable carburetor cleaner, rinse all parts as directed by carburetor cleaner manufacturer. Dry all parts and blow out all passages with compressed air.

3) When cleaning or overhauling a carburetor, identify the carburetor by the code stamped adjacent to the fuel inlet and order a complete Repair Kit for the carburetor being worked on. Check all valves and shafts for binding or damage.

Reassembly

Reverse disassembly procedure using new parts and gaskets contained in the Repair Kit. When reassembling float bowl, be sure to adjust float level and make all other adjustments. See "Adjustment" in this article.

Automatic Choke Reassembly (4MC Carb.) - 1) Install cup seal in plastic insert on side of float bowl (lip facing outward). Install fast idle cam on intermediate choke shaft with steps on cam facing downward. Install new cup seal inside choke housing (lips facing inward toward inside of housing), then install fast idle cam and intermediate shaft through seal in choke housing.

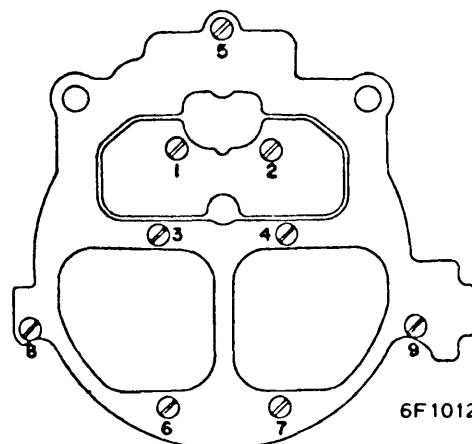

AIR HORN SCREW ATTACHING SEQUENCE

ROCHESTER 4MC & 4MV 4-BARREL (Cont.)

2) Install thermostatic coil lever on intermediate choke shaft flats so that both inside and outside levers face toward fuel inlet, then tighten retaining screw. Install lower choke rod lever in float bowl cavity. Install vacuum seal in choke housing cavity.

3) Install housing on bowl and slide intermediate shaft into lower choke lever. If choke housing correctly installed, tang on lever should be beneath fast idle cam. Do not install choke cover and coil assembly until choke coil lever adjustment is completed. See "Adjustment" in this article.

Vacuum Break Installation – If vacuum break diaphragm was removed from bracket, slide vacuum break diaphragm between retaining ears and bend ears down slightly to hold assembly securely. Install fast idle cam on vacuum break assembly.

Air Horn Installation – To prevent distortion of the air horn and binding of choke valve or air valve, tighten all air horn screws in correct sequence as shown in the accompanying illustration.