

ROCHESTER 2GC & 2GV 2-BARREL

ROCHESTER 2GC

OLDSMOBILE	Man. Trans.	Auto. Trans.
350" V8		
Omega.....		7043158
Cutlass.....		7043154
88.....		7043152
PONTIAC		
350" V8		
Exc. Grand Prix.....		① 7043062
Exc. Grand Prix.....		② 7043063
Firebird, Ventura		
LeMans, Grand Am.....	7043071	
Firebird, Ventura		
LeMans, Grand Am.....		7043072
400" V8		
LeMans, Grand Am,		
Ventura.....		① 7043060
LeMans, Grand Am,		
Ventura.....		② 7043061
Catalina Station Wagon,		
Grand Ville Station Wagon.....		① 7043067
Catalina, Bonneville,		
Grand Ville, Exc. Wagons.....		① 7043066
Catalina, Bonneville,		
Grand Ville.....		② 7043607
LeMans, Grand Am,		
Catalina, Bonneville,		
Grand Ville, Firebird.....		7043070

ROCHESTER 2GV

CHEVROLET

307" V8		
Nova, Chevelle.....	7043101	7043100
Camaro.....	7043105	7043120
350" V8		
Chevelle, Chevrolet		
Monte Carlo, Nova.....	7043113	7043114
Camaro.....	7043111	7043112
400" V8		
Monte Carlo,		
Chevrolet.....		7043118

BUICK

350" V8 All.....	7043143	7043142
------------------	---------	---------

- ① - Non-Calif.
- ② - Calif. Only.

CARBURETOR IDENTIFICATION

Rochester carburetor part number is stamped on a horizontal section of the float bowl, near the fuel inlet nut. When float bowl assembly is being replaced, manufacturers instructions contained in service package, must be followed so that part number is transferred to the new float bowl.

DESCRIPTION

Carburetors are of a 2-barrel downdraft type with side fuel bowl, 2GC models are equipped with an automatic integral choke. The automatic choke housing and thermostatic coil of

the 2GC may be located on the air horn or throttle body, depending on application. The 2GV carburetor is also an automatic choke model, however, a vacuum break diaphragm unit is used in place of the conventional choke housing and piston. Two different sizes of the 2GV carburetor are used. The 2GV-1 1/4" models are used on the 307" V8's and the 2GV-1 1/2" are used on all other applications. An Exhaust Gas Recirculation system is used in conjunction with these carburetors. The vacuum supply necessary to operate the EGR valve is located in the throttle body and connects through a channel to a tube which is located on the choke side of the float bowl.

Idle Stop Solenoid - Some carburetors come equipped with an idle stop solenoid, which is used to control curb idle speed and prevent engine dieseling.

Idle Limiter Caps - Idle mixture needles are preset at factory and capped with plastic limiter caps to prevent readjustment in the field. Idle mixture limiter caps should not be removed except in the case of carburetor overhaul. New (red) plastic limiter caps are provided in each repair kit.

Exhaust Gas Recirculation - A vacuum supply tube, installed in the carburetor throttle body, connects to a timed verticle port in the throttle body bore. This provides a vacuum signal to the EGR valve. The EGR valve is mounted on the intake manifold and is used to circulate exhaust gases into the combustion chamber to lower combustion temperatures.

ADJUSTMENT

IDLE SPEED & MIXTURE

▶ **NOTE** - Carburetors have plastic idle limiter caps on idle mixture adjusting screws. No attempt to adjust idle mixture screws should be made. If caps are removed during such operations as carburetor overhaul, fuel bowl replacement, or throttle body replacement, special procedures are required to readjust idle mixture screws. See "General Motors Tune-Up" in Exhaust Emission Manual.

Idle Speed (Buick) - Make adjustment with engine at normal operating temperature, air cleaner installed, choke open, and air conditioner OFF. Disconnect hose from air cleaner to vapor canister. Disconnect and plug distributor vacuum hose. Open throttle sufficiently to permit idle solenoid to extend and contact throttle lever pad in idle position. Adjust solenoid set screw to obtain higher RPM listed. **NOTE** - Solenoid mounting bracket may be moved for additional adjustment. Disconnect solenoid wire and adjust idle screw to obtain lower RPM listed.

Idle Speed (Chevrolet) - Make adjustment with engine at normal operating temperature, air cleaner installed, choke open, and air conditioner OFF. Disconnect fuel tank hose at vapor canister. Disconnect distributor vacuum hose at distributor and plug. Disconnect electrical connection at idle stop solenoid, then adjust low idle screw to the lower RPM listed (see specification table). Reconnect solenoid, open throttle momentarily and adjust solenoid plunger screw to higher RPM listed in table.

ROCHESTER 2GC & 2GV 2-BARREL (Cont.)

CARBURETOR ADJUSTMENT SPECIFICATIONS									
Rochester Carb. No.	Hot Idle Speed (Engine RPM) ①		Float Level Setting	Float Drop Setting	Pump Rod Setting	Choke Rod Setting	Vacuum Break Setting	Unloader Setting	Auto. Choke Setting
	Man. Trans.	Auto. Trans.							
7043100	600/500	21/32"	1 9/32"	1 5/16"	.150"	.080"	.215"	②
7043101	900/500	21/32"	1 9/32"	1 5/16"	.150"	.080"	.215"	②
7043120	600/500	21/32"	1 9/32"	1 5/16"	.150"	.080"	.215"	②
7043105	900/500	21/32"	1 9/32"	1 5/16"	.150"	.080"	.215"	②
7043114	600/400	19/32"	1 9/32"	1 7/16"	.245"	.130"	.325"	②
7043113	900/400	19/32"	1 9/32"	1 7/16"	.200"	.140"	.250"	②
7043112	600/400	19/32"	1 9/32"	1 7/16"	.245"	.130"	.325"	②
7043111	900/400	19/32"	1 9/32"	1 7/16"	.200"	.140"	.250"	②
7043118	600/500	19/32"	1 9/32"	1 7/16"	.245"	.130"	.325"	②
7043062	650	21/32"	1 9/32"	1 5/16"	.085"	.167"	.180"	1 Lean
7043063	650	21/32"	1 9/32"	1 5/16"	.085"	.167"	.180"	1 Lean
7043071	900/600	23/32"	1 9/32"	1 5/16"	.085"	.195"	.180"	1 Lean
7043072	650	23/32"	1 9/32"	1 5/16"	.085"	.167"	.180"	1 Lean
7043060	650	21/32"	1 9/32"	1 5/16"	.085"	.157"	.180"	1 Lean
7043061	650	21/32"	1 9/32"	1 5/16"	.085"	.157"	.180"	1 Lean
7043066	650	21/32"	1 9/32"	1 5/16"	.085"	.180"	.180"	1 Lean
7043067	650	21/32"	1 9/32"	1 5/16"	.085"	.180"	.180"	1 Lean
7043070	650	23/32"	1 9/32"	1 5/16"	.085"	.157"	.180"	1 Lean
7043143	800/600	15/32"	1 9/32"	1 15/32"	.080"	③ .150"	.200"	②
7043142	650/500	15/32"	1 9/32"	1 15/32"	.080"	③ .140"	.180"	②
7043158	700/550	15/32"	1 9/32"	1 11/32"	.160"	.200"	.250"	INDEX
7043154	700/550	15/32"	1 9/32"	1 11/32"	.160"	.200"	.250"	INDEX
7043152	700/550	15/32"	1 9/32"	1 11/32"	.160"	.200"	.250"	INDEX

- ① - Higher Speed - Solenoid Energized. Lower Speed - Solenoid De-Energized.
 ② - See "Adjustment" Section.
 ③ - Secondary .120".

Idle Speed (Oldsmobile) - Make adjustment with engine at normal operating temperature, air cleaner installed, choke open, and air conditioner OFF. Disconnect and plug carburetor hoses from vapor canister, EGR valve, and distributor vacuum unit. Adjust solenoid (energized) screw to specified higher RPM. Then adjust carburetor speed screw (solenoid de-energized) to specified lower RPM.

Idle Speed (Pontiac) - Make adjustment with engine at normal operating temperature, air cleaner installed, choke open, and air conditioner OFF. Disconnect carburetor hose from vapor canister. Disconnect distributor and EGR valve vacuum hoses, plug hoses leading to carburetor. Disconnect throttle solenoid wire (idle stop solenoid if equipped). Adjust carburetor speed screw to obtain RPM listed in table. Then reconnect solenoid wire and adjust to higher RPM.

NOTE - Carburetors are equipped with locked mixture screws (limiter caps). Do not attempt to adjust these screws as they are preset at the factory.

FLOAT LEVEL (METAL FLOAT)

Invert air horn assembly with gasket in place. Measure from face of gasket to lower (sharp) edge of float seam at free end of float. Obtain specified clearance (see specifications) by bending float arm.

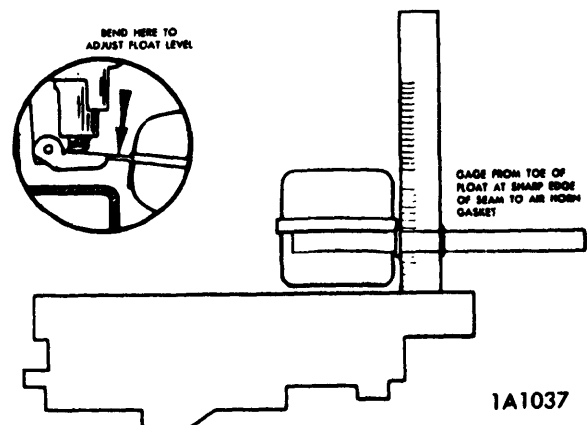

FLOAT LEVEL ADJUSTMENT (METAL FLOAT)

ROCHSTER 2GC & 2GV 2-BARREL (Cont.)

FLOAT DROP (METAL FLOAT)

With bowl gasket in place, hold bowl cover in normal position, measure distance from gasket to bottom of float at lowest point. If distance is incorrect (see specifications) bend tang, on float, that rests against needle valve.

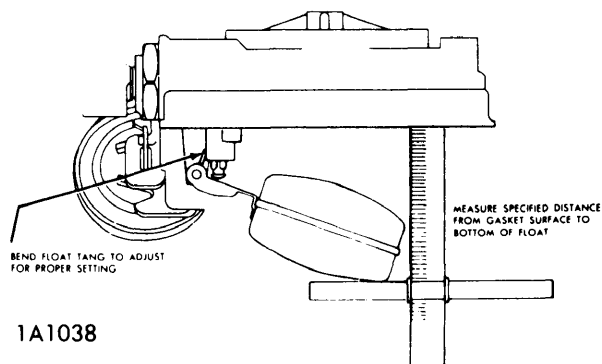

FLOAT DROP ADJUSTMENT (METAL FLOAT)

FLOAT LEVEL (PLASTIC FLOAT)

With bowl gasket in place, invert bowl cover and measure distance from gasket to lip on free end of float. If distance is incorrect (see specifications) adjust by bending float arm.

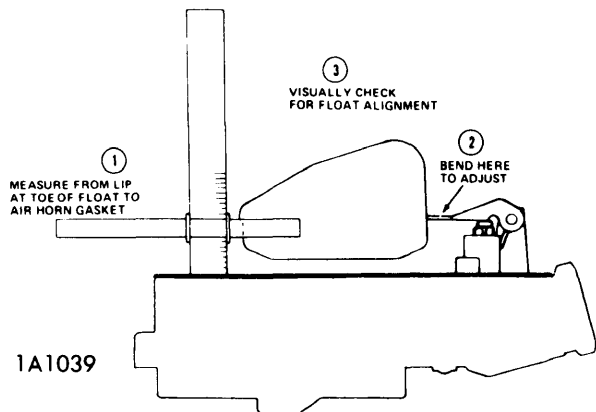

FLOAT LEVEL ADJUSTMENT (PLASTIC FLOAT)

FLOAT DROP (PLASTIC FLOAT)

Hold bowl cover in normal position with gasket in place, and measure distance from gasket to notch on free end of float. If distance is incorrect (see specifications), adjust by bending tang on float that rests against needle valve.

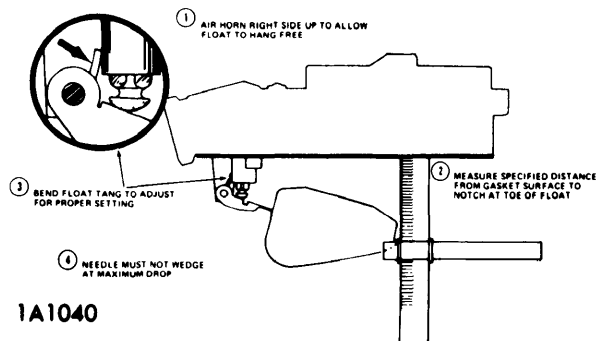

FLOAT DROP ADJUSTMENT (PLASTIC FLOAT)

ACCELERATOR PUMP

With throttle stop screw and fast idle screw (when used) backed out so that throttle valves are completely closed, measure distance from top of air horn ring to top of pump connector rod at pump lever. If distance is incorrect (see specifications), adjust by bending pump connector rod at existing bend.

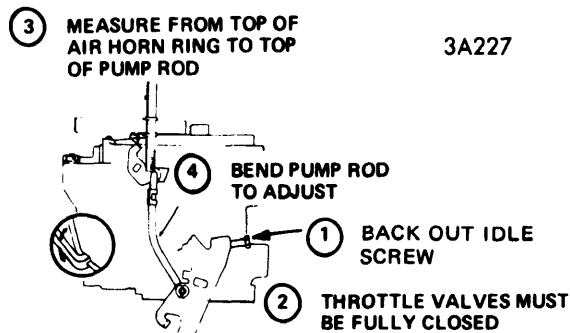

PUMP ROD ADJUSTMENT

CHOKE ROD (FAST IDLE CAM)

2GC Carburetors – Position fast idle screw on second step of fast idle cam and against shoulder of high step. Measure distance between upper edge of choke valve and air horn wall (see specifications, Choke Rod Setting). Adjust by bending tang at upper end of choke rod.

2GV Carburetors – Place fast idle screw on second step of fast idle cam and against shoulder of high step. With choke valve held closed, measure distance between upper edge of choke valve and air horn wall (see specifications, Choke Rod Setting). To adjust bend tang as shown in illustration.

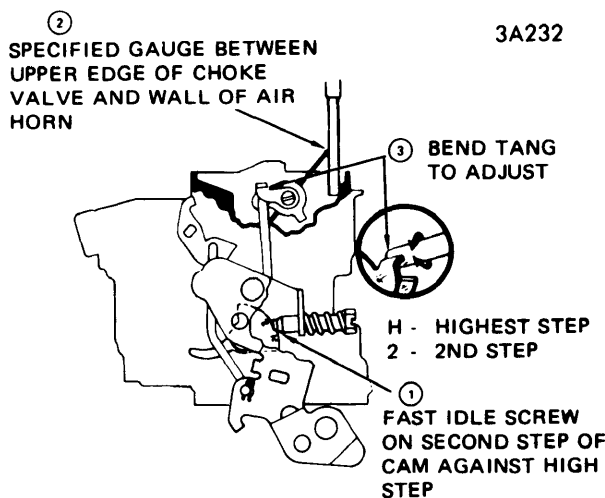

CHOKE ROD (FAST IDLE CAM) ADJUSTMENT – 2GV

VACUUM BREAK (2GV CARBS)

NOTE – Buick carburetors have two vacuum break units, a primary and a secondary, which must be adjusted separately.

ROCHESTER 2GC & 2GV 2-BARREL (Cont.)

Buick Primary - This unit is mounted on throttle lever side of carburetor. Seat vacuum break diaphragm using an outside vacuum source, or push diaphragm plunger inward until seated. Rotate choke valve toward closed position so that vacuum break rod is at bottom end of slot in choke valve lever (make certain fast idle screw does not hang up on fast idle cam and prevent choke valve from closing). Gauge clearance between upper edge of choke valve and air horn wall. If clearance is incorrect (see specifications), adjust by bending vacuum break rod at existing bend.

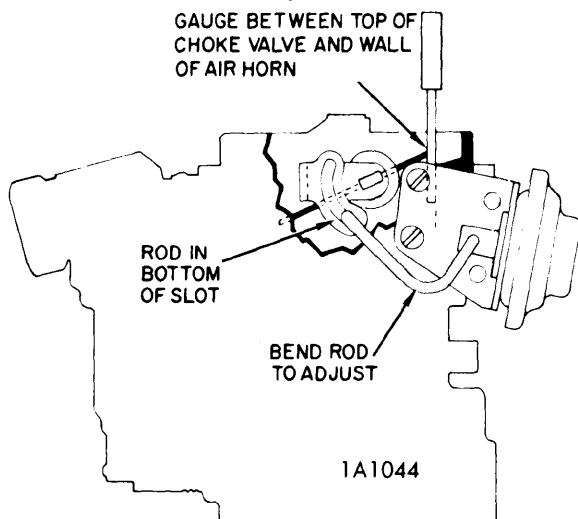

PRIMARY VACUUM BREAK ADJUSTMENT (BUICK)

Buick Secondary - Unit is mounted opposite of primary vacuum break. Use outside vacuum source to hold diaphragm in seated position. (CAUTION - It will require approximately 8 seconds for diaphragm to fully contract. BE SURE to plug small bleed hole in diaphragm tube beneath filter element). Rotate choke valve towards a closed position with vacuum break rod at lower end of slot in choke valve lever until spring loaded diaphragm is fully extended. (CAUTION - Do not use extreme force to compress spring, use just enough force to fully compress spring without pulling vacuum diaphragm off its seat). Hold choke valve in this position and gauge clearance between upper edge of choke valve and air horn wall, if clearance is incorrect (see specifications), adjust by bending vacuum break link at existing loop as required.

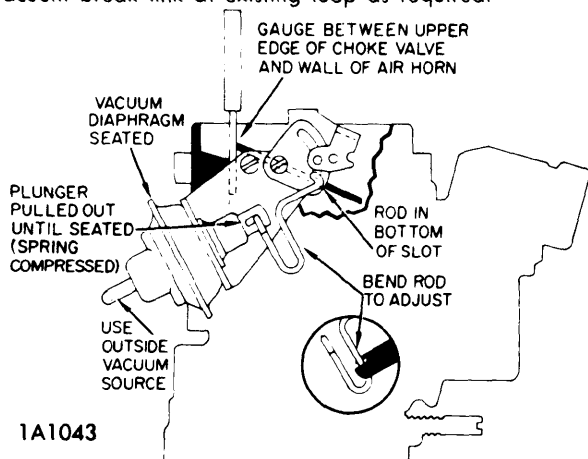

SECONDARY VACUUM BREAK ADJUSTMENT (BUICK)

Chevrolet - Remove air cleaner assembly, and on vehicles with a "Therm AC" type air cleaner, plug the sensor's vacuum take off port. Using an outside vacuum source, apply vacuum to vacuum break diaphragm until the plunger is fully seated. With vacuum break diaphragm in fully seated position, push choke valve towards the closed position. With choke valve held in this position, and choke rod in end of diaphragm plunger (see illustration), check clearance between upper edge of choke valve and air horn (see specifications). To adjust, bend at existing bend.

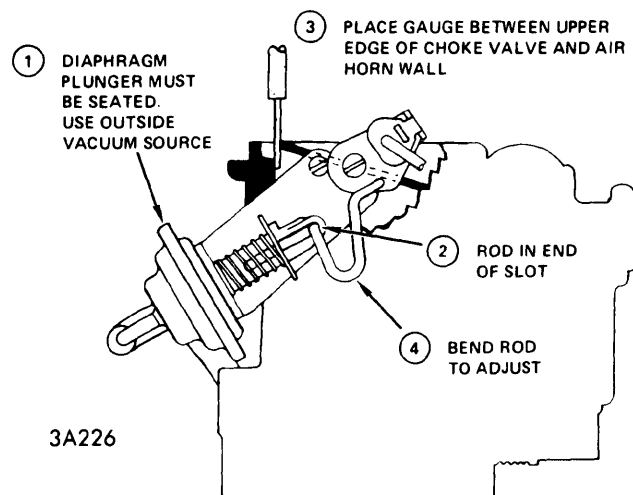

VACUUM BREAK ADJUSTMENT 2GV & 2GC

VACUUM BREAK (2GC CARBS)

Pontiac - Using an outside vacuum source apply vacuum to vacuum break diaphragm until it is fully seated. Pull diaphragm plunger out until rod is fully seated in slot in plunger. With choke valve held in closed position, measure clearance between upper edge of choke valve and air horn wall (see specifications). Bend at existing bend to adjust. **NOTE** Be sure fast idle screw is on highest step of cam.

Oldsmobile - Using an outside vacuum source to fully seat vacuum diaphragm, make sure that fast idle screw is on high step of fast idle cam. Push choke valve fully closed until spring loaded diaphragm plunger is fully extended with rod at outer end of plunger slot. Check clearance between choke valve and air horn wall. If clearance is incorrect (see specifications), adjust by bending at existing bend.

INTERMEDIATE CHOKE ROD (2GC)

Remove thermostatic cover, coil assembly, and inside baffle plate. Place fast idle screw on highest step of fast idle cam. Close choke valve. Edge of coil lever must line up with edge of .120" plug gauge inside choke housing. Bend vacuum break link at large loop to correct clearance.

ROCHESTER 2GC & 2GV 2-BARREL (Cont.)

UNLOADER (ALL MODELS)

With throttle valves held wide open, and choke valve held toward closed position with a rubber band, bend unloader tang on throttle lever to obtain specified clearance (see specifications) between upper edge of choke plate and air horn wall. See illustration.

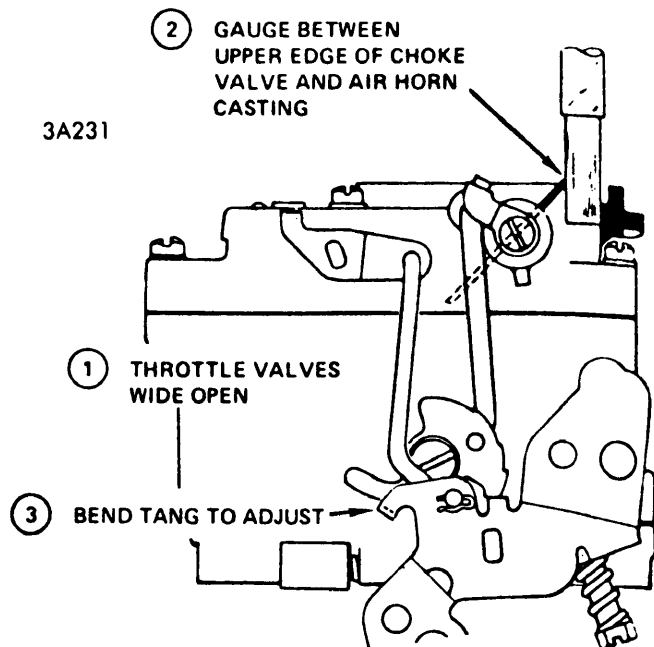

UNLOADER ADJUSTMENT

AUTOMATIC CHOKE (2GV CARBS)
(CHOKE COIL ROD)

Disconnect choke rod at choke valve lever and check choke valve rod length for each car model as detailed below.

Buick - Close choke valve completely. Pull up on choke rod to end of travel. End of rod should just fit into gauge notch in lever. To adjust, bend rod at angle.

Chevrolet - Hold choke valve completely open. With thermostatic coil rod disconnected from upper lever, push downward on rod to end of travel. With rod in fully downward position, bottom of rod should be even with bottom of slotted hole in lever. To adjust, bend lever at point shown in illustration with screwdriver end.

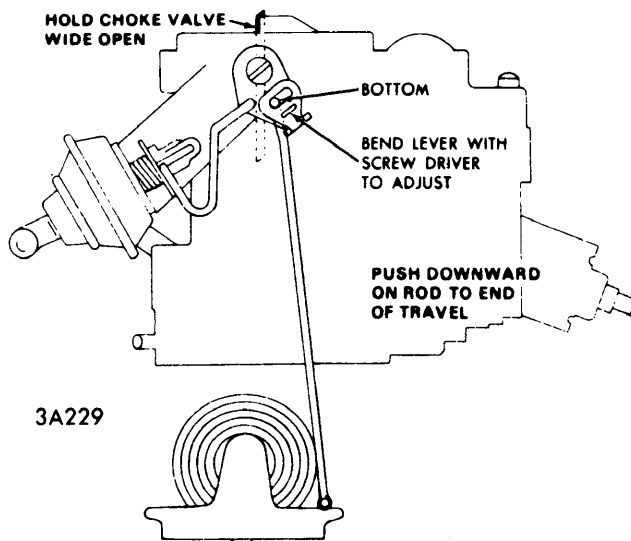

CHOKE COIL ROD ADJUSTMENT - 2GV

AUTOMATIC CHOKE (2GC CARBS)
(CHOKE COIL ROD)

Oldsmobile - Loosen three retaining screws on choke coil cover. Rotate cover until index mark on cover is aligned with correct mark on choke coil housing (see specifications).

Pontiac - Place fast idle screw on highest step of cam. Loosen three retaining screws on choke coil cover. Rotate cover until index mark on cover is aligned with correct mark on choke coil housing (see specifications).

OVERHAUL

Carburetor cleaning and overhaul is generally the result of a customer complaint that cannot be remedied by external adjustments or parts replacement with the carburetor installed on the engine.

Flooding, stumble on acceleration and other performance complaints are, in many instances, caused by dirt, water or other foreign matter in the carburetor fuel bowl, jets or passages. To aid in diagnosing the cause of complaint, the carburetor should be carefully removed from the engine so as not to agitate or drain the fuel in the bowl. Contents of the fuel bowl may then be examined as the carburetor is disassembled.

When cleaning and overhauling a carburetor, identify the carburetor by the model number stamped on the main body,

adjacent to the fuel inlet fitting. Using this number, always order and install a complete Repair Kit which contains the necessary parts and gaskets.

Disassembly

1) Remove fuel inlet fitting, gasket, fuel filter and spring. Remove pump rod by removing lower retaining clip and rotating pump rod until lug on upper end of rod passes through upper pump lever. Remove fast idle cam attaching screw, then remove fast idle cam and rod assembly by rotating until lug on upper end of choke rod passes through slot in upper choke lever and collar assembly.

2) Remove vacuum break diaphragm hoses, from both units (if so equipped). Remove primary vacuum break diaphragm by removing two attaching screws, remove break rod from

ROCHESTER 2GC & 2GV 2-BARREL (Cont.)

lever by rotating rod until end slides out of slot in lever and lug on other end of rod out of slot of diaphragm plunger shaft. Remove secondary vacuum break unit (if equipped) by removing lever from end of choke shaft, then remove lever from diaphragm plunger rod and rod from plunger shaft. Remove bracket attaching screws and remove diaphragm and bracket assembly.

3) Remove air horn attaching screws and guide air horn gently upward from bowl. Invert air horn and remove float hinge pin and float assembly, remove float needle from arm, then remove float needle seat and gasket. Remove power piston by depressing stem and allowing it to snap free. Remove pump plunger assembly from inner pump arm by rotating assembly until end of shaft will slide out of hole in inner pump lever. Loosen set screw on inner arm and remove outer lever and shaft assembly. **NOTE** - Plastic washer used between outer pump lever and air horn casting, do not immerse in carburetor cleaner.

4) Remove choke valve retaining screws and remove choke valve from shaft. Remove shaft, then remove lever and collar assembly from shaft, noting position of choke lever in relation to trip lever on choke shaft, for easier assembly.

5) Remove pump plunger return spring from well, then remove check ball by inverting bowl and shaking into hand, remove pump inlet screen. Remove main jets, power valve and gasket. Remove venturi attaching screws (3), cluster and gasket. **NOTE** - Center cluster has smooth shank and fibre gasket to seal accelerator pump by-pass.

6) Remove plastic main well inserts, then using needle-nose pliers, remove pump discharge ball spring "T" retainer and remove discharge spring and ball. **NOTE** - Throttle body assembly is serviced as a complete unit. Invert carburetor and remove throttle body to bowl attaching screws, throttle body and body to bowl gasket. On 2GC carburetors, remove choke cover attaching screws, retainer, cover and coil assembly and gasket. Also on 2GC, remove baffle plate from inside choke housing, then remove choke

housing attaching screws (2), choke housing and gasket; remove screw from end of intermediate choke shaft, then remove intermediate choke lever, choke coil lever, shaft assembly and dust seal from choke housing.

Cleaning & Inspection

Clean all carburetor castings and metal parts in cleaning solvent. Do not immerse choke housing, coil assembly, pump plunger, or vacuum break diaphragm in solvent. Clean pump plunger in clean gasoline. Clean vacuum break diaphragm with clean cloth. Blow out all passages with compressed air. Inspect all parts for wear or damage and replace as necessary.

Reassembly

Use all new gaskets. Reassemble carburetor by reversing disassembly procedure and noting the following:

Idle Mixture Screws & Limiter Caps - After installing mixture screws and springs, back out screws 2 turns as a preliminary idle adjustment. Do not install new limiter caps until idle mixture has been completed.

Choke Valve Installation - Install valve with identifying mark "RP" upward, center choke valve before tightening screws. **NOTE** - Valve can be centered by installing fast idle lever and choke trip lever on end of shaft and maintaining .020" clearance between fast idle lever and air horn casting, or between choke trip lever and choke lever and collar assembly. Stake choke valve screws lightly after tightening. Choke valve should move freely in housing.

Accelerating Pump Assembly - Lubricate pump shaft with suitable lubricant (light grease) when installing in bowl cover. Make certain that pump check balls are not interchanged. Inlet check ball is aluminum, discharge check ball is steel. **NOTE** - Some models may have a two-piece pump plunger assembly in place of an inlet check ball.

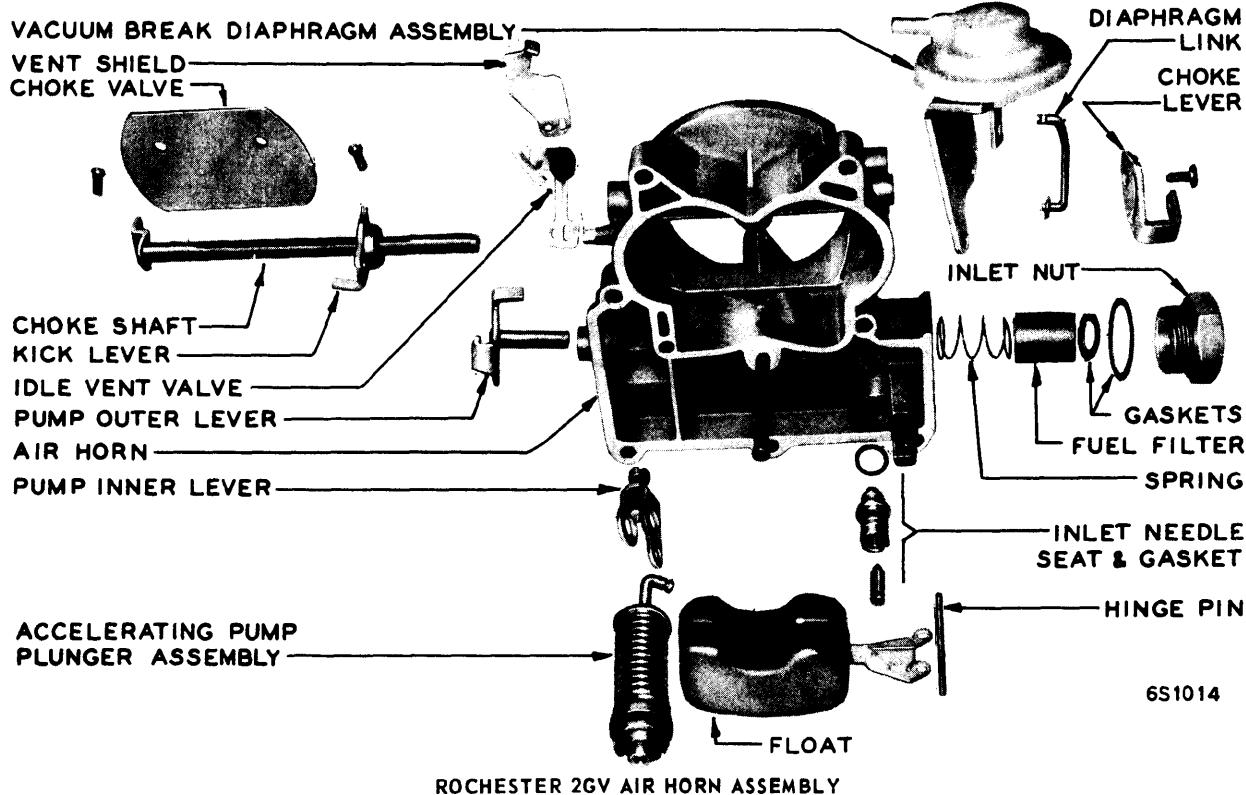

6S1014

ROCHESTER 2GC & 2GV 2-BARREL (Cont.)

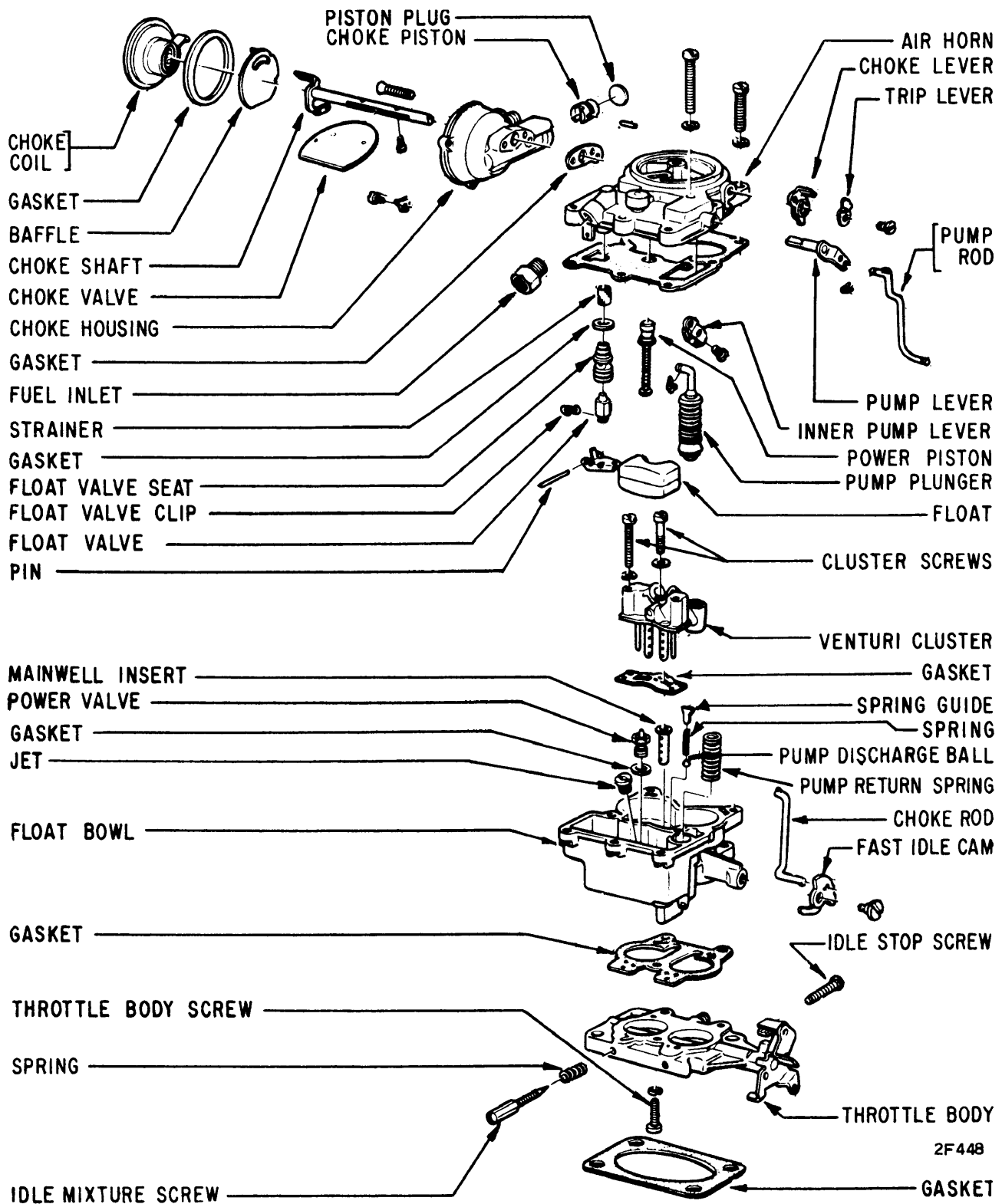

ROCHESTER 2-BARREL CARBURETOR (AUTO CHOKE ON AIR HORN)