

## HOLLEY 2-BARREL MODEL 2210

### CHRYSLER CORP.

#### Holley Carburetor No.

Application	Man. Trans.	Auto. Trans.
360" V8 (Exc. Calif.).....		R-6452A
(Calif.).....		R-6575A
400" V8 (Exc. Calif.).....		R-6454A
(Calif.).....		R-6472A

system is designed to afford a more rapid choke opening at temperatures above 63°F and slower opening at lower temperatures.

### CARBURETOR IDENTIFICATION

Holley part number stamped on fuel bowl. Prefix letter "R" indicates complete carburetor assembly. Suffix letter "A" indicates an assembly. A suffix numeral indicates modification from original specifications.

### DESCRIPTION

2-Bbl. downdraft of conventional design. Choke valve in air horn is operated by remote thermostatic choke coil and connecting rod. Features new for 1973 are as follows:

#### ELECTRIC ASSIST CHOKE SYSTEM

System is composed of an electric heating element mounted adjacent to the conventional thermostatic choke coil (see illustration), and a thermostatic choke control switch. The

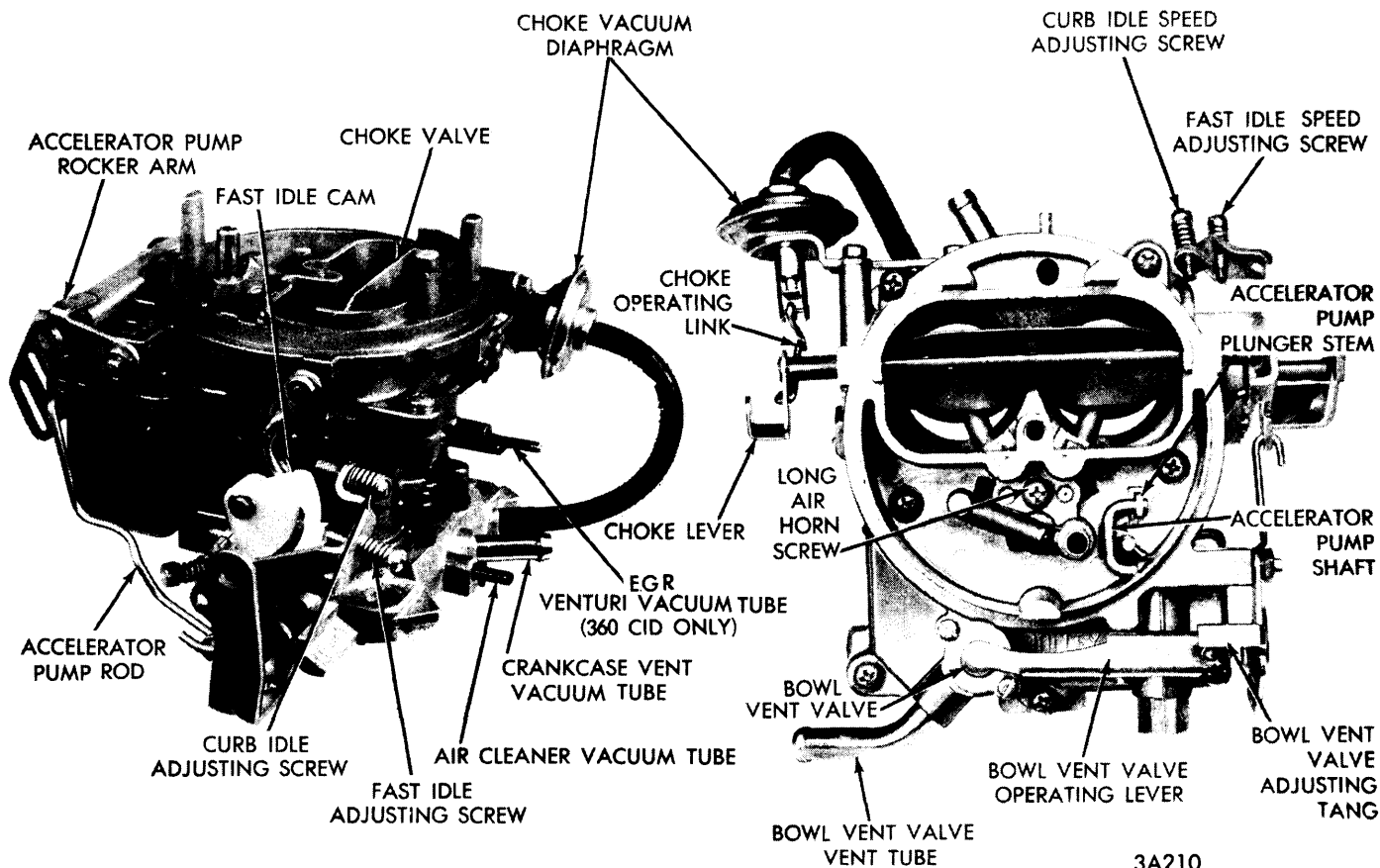
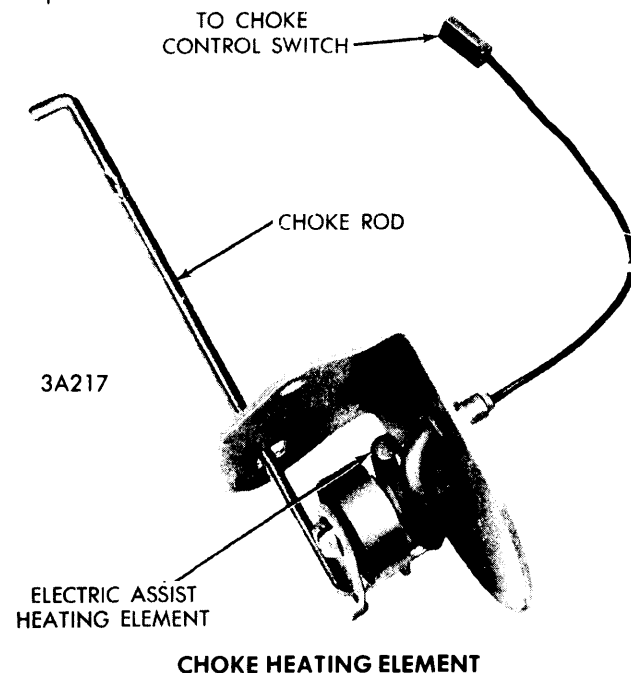

HOLLEY MODEL 2210 CARBURETOR ASSEMBLY

## HOLLEY 2-BARREL MODEL 2210 (Cont.)

CARBURETOR ADJUSTMENT SPECIFICATIONS							
Holley Carb. No.	Idle Speed (Engine RPM)		Accel. Pump <sup>⊙</sup> Setting	Float Setting	Fast Idle Cam Setting	Vacuum Kick Setting	Choke Unloader Setting
	Hot	Fast					
R-6452A	750	1900	.250"	.180"	.110"	.150"	.170"
R-6454A	700	1800	.250"	.180"	.110"	.150"	.170"
R-6472A	700	1800	.250"	.180"	.110"	.150"	.170"
R-6575A	750	1900	.250"	.180"	.110"	.150"	.170"

⊙ With pump connector rod in #3 slot.

**NOTE** — Since the choke heating element receives its electrical input from the ignition circuit (through the control switch), a short in the wiring or within the heater itself will also result in a short in the ignition circuit.

#### ELECTRIC CHOKE ASSIST CONTROL SWITCH

Connected in series between the ignition circuit and the choke heater, the switch will energize the choke heater when underhood temperature is above 63°F. When the control switch is warmed to approximately 110°F by engine heat and a small electrical heating element within the switch, the switch will de-energize the choke heater. Adjustment is not possible on either the choke assist heating element, the choke thermostatic coil or the control switch.

**NOTE** — For testing procedures on both the choke assist and control switch, see appropriate article in *Exhaust Emission Manual*.

#### NEW VACUUM PORTS & NIPPLES

Model 2210 carburetors used on vehicles with 360" and 400" engines equipped with EGR (Exhaust Gas Recirculation) systems have an additional vacuum port and nipple. These ports function to control the EGR system by signalling the EGR control valve.

**360" Engine** — Carburetors used on these engines obtain vacuum control of the EGR system by utilizing a **Venturi Vacuum Control System**. The vacuum port is located in the side of the carburetor above the throttle valves. Because of the comparatively low vacuum obtained above the throttle valves, a "Vacuum Amplifier" is required to operate the EGR control valve.

**400" Engine** — Carburetors used on these engines use a **Ported Vacuum Control System**. This control system has a slot type port in the carburetor throttle body which is exposed to an increasing percentage of manifold vacuum as the throttle valves open. The port is connected through an external nipple directly to the EGR control valve. Vacuum flow and intensity is dependent on manifold vacuum, throttle position, and exhaust gas back pressure.

#### ADJUSTMENT

##### Idle Speed & Mixture

Set the following conditions before making adjustments. Engine running at normal operating temperature automatic transmission in NEUTRAL (not PARK), air cleaner in position, timing set to specification, A/C OFF.

**Idle Speed** — Use idle speed stop screw to obtain specified idle RPM (see Specifications).

**Idle Mixture** — Requires special procedure. See *Chrysler Corporation Tune-Up in Exhaust Emission Manual*.

**NOTE** — If idle speed changes as idle mixture is adjusted, readjust to specification.

##### Fast Idle Speed & Cam Position

Fast idle speed adjustment must be made on car with engine running. Cam position adjustment should be made first, and can be performed either on the vehicle or on the bench.

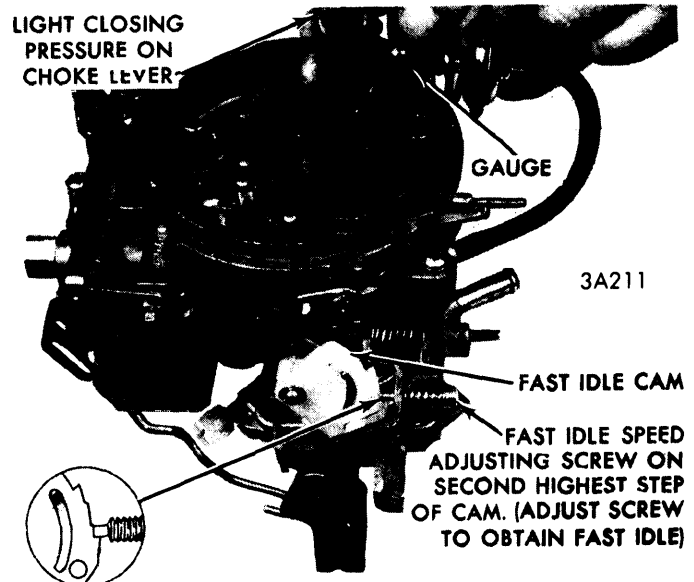

ADJUSTING FAST IDLE CAM POSITION

## HOLLEY 2-BARREL MODEL 2210 (Cont.)

**Cam Position** – With fast idle speed adjusting screw on second highest speed step of fast idle cam move choke valve toward closed position with light pressure on choke lever. Insert drill gauge (see Specifications) between top of choke valve and air horn. If slight drag not obtained as gauge removed adjust clearance by bending connector rod at angle.

**Fast Idle Speed** – With engine at normal operating temperature but not running and transmission in Park or Neutral and with curb idle speed and mixture at specifications proceed as follows:

- 1) Open throttle slightly and close choke valve to position fast idle adjusting screw on second highest speed step of fast idle cam.
- 2) Start engine and determine stabilized RPM. Adjust fast idle speed screw to secure specified fast idle RPM. (See Specifications).
- 3) Reposition fast idle speed screw on cam after each adjustment to provide correct throttle closing torque.

### AUTOMATIC CHOKE

New choke unit contains electric assist heating element controlled by thermostatic switch. Both the choke and control switch are serviced as an assembly only. No adjustment is necessary or possible. *NOTE* – For testing procedures, see appropriate article in Exhaust Emission Manual.

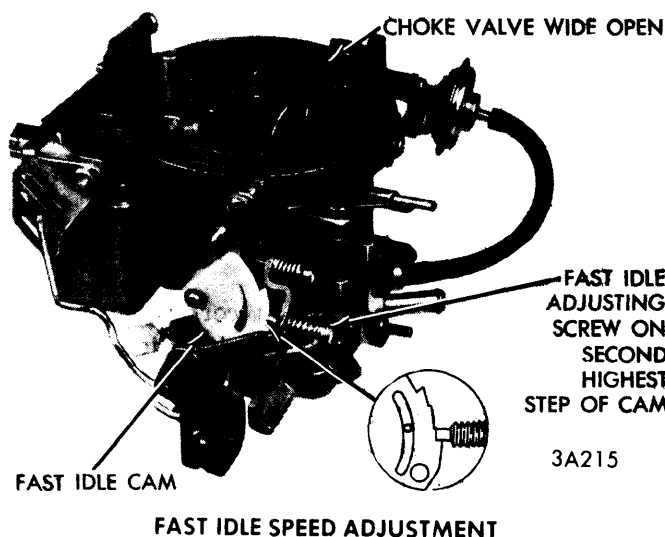

### Vacuum Break (Kick)

*NOTE* – Adjustment can be made on or off car, using an auxiliary vacuum source (distributor test machine, or another vehicle), or on the car with engine running. When using auxiliary vacuum source, remove vacuum break hose from carburetor, NOT from vacuum break diaphragm. If adjustment is made with engine running, back off fast idle screw until choke will close to kick position with engine at curb idle (note number of turns, to properly reset fast idle after adjustment). If auxiliary vacuum source is used, open throttle valve (engine not running) and move choke to closed position. Release throttle, then release choke. Apply a minimum of 10" or more of mercury. Insert drill (see Specifications) between top of choke valve and

wall of air horn. Apply sufficient pressure on choke rod lever to give minimum choke valve opening without distorting diaphragm link. *NOTE* – Diaphragm internal spring must be fully compressed, as will be noted by extension of diaphragm stem. A slight drag should be felt as drill is withdrawn, if not, adjust by opening or closing U-bend in diaphragm link. *CAUTION* – Do not apply twisting or bending force to diaphragm.

### Choke Unloader

With throttle valves wide open insert drill gauge (see Specifications) between upper edge of choke valve and air horn. With slight pressure on choke shaft lever, slight drag should be felt as gauge removed. Bend unloader tang on throttle lever if adjustment needed.

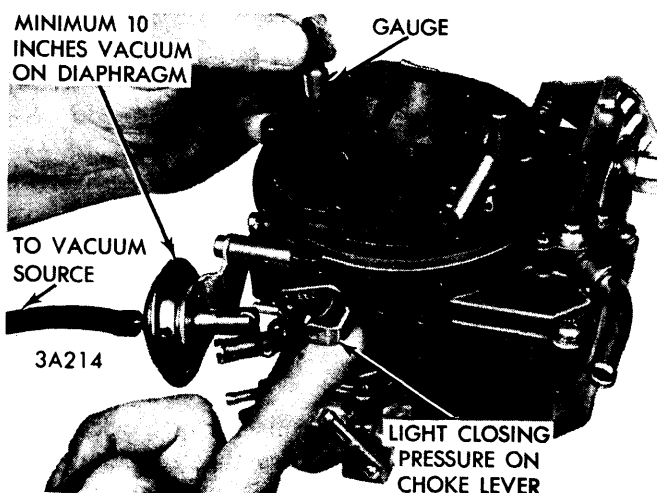
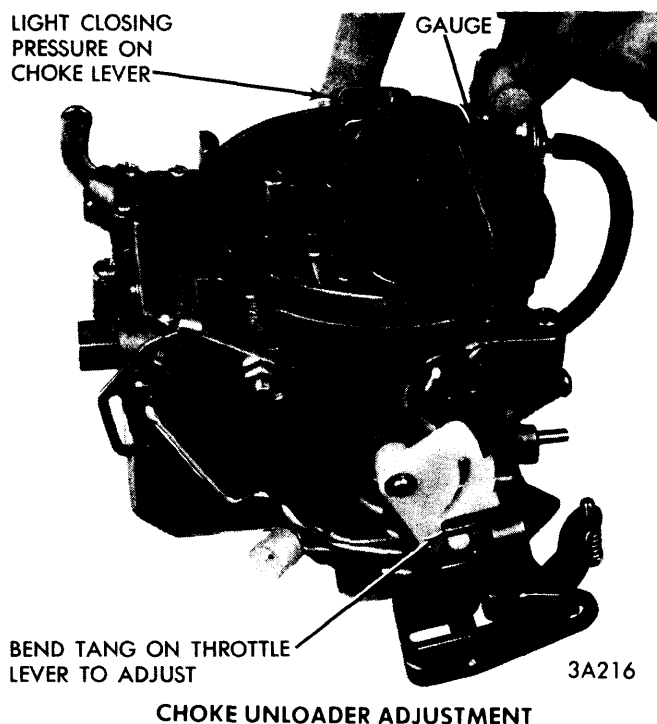

ADJUSTING CHOKE VACUUM KICK

## HOLLEY 2-BARREL MODEL 2210 (Cont.)

### Accelerator Pump

Seat throttle valves in bores by backing off curb idle speed screw and opening choke valve. Pump connector rod must be installed in correct slot of accelerator pump rocker arm (see Specifications). Measure distance between top of air horn and end of plunger shaft (see Specifications). If adjustment is required, bend pump operating rod, at loop of rod, until correct setting has been obtained.

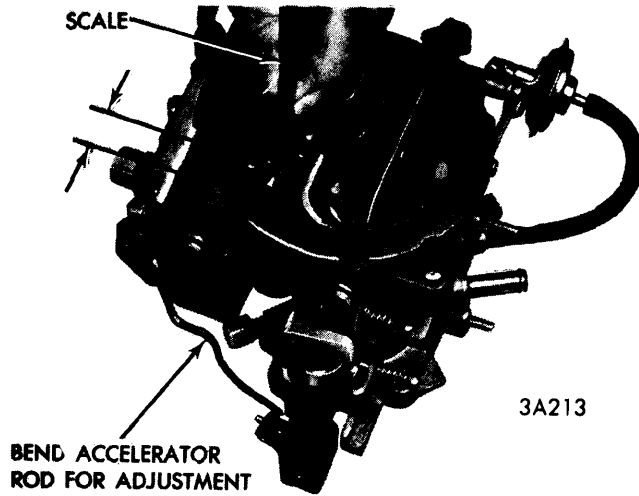

ACCELERATOR PUMP ADJUSTMENT

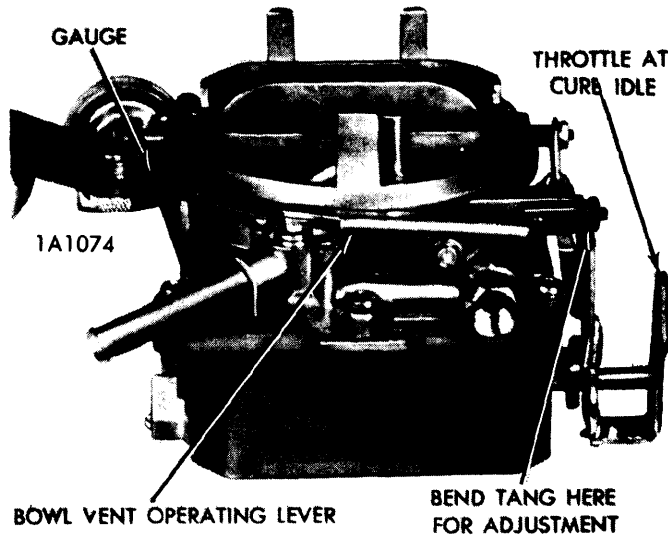

ADJUSTING BOWL VENT

### BOWL VENT VALVE ADJUSTMENT

With throttle valves at curb idle position, clearance between bowl vent valve plunger stem and operating rod should be .015" (see illustration). To adjust, bend tang on pump lever and obtain .015" clearance.

### Float Setting

*NOTE - When measuring float setting, be sure that weight of float only is forcing needle on seat.*

With air horn inverted measure clearance between top of float and float stop (see Specifications). Drill or gauge must be perfectly level when measuring. Bend float lip as required if adjustment necessary.

### Float Drop

With air horn in normal position bottom edge of float should be parallel to underside surface of air horn. Bend tang on float arm to obtain correct adjustment.

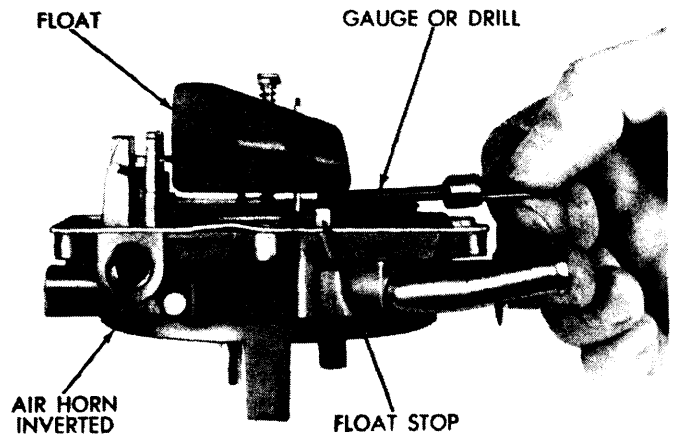

CHECKING FLOAT SETTING

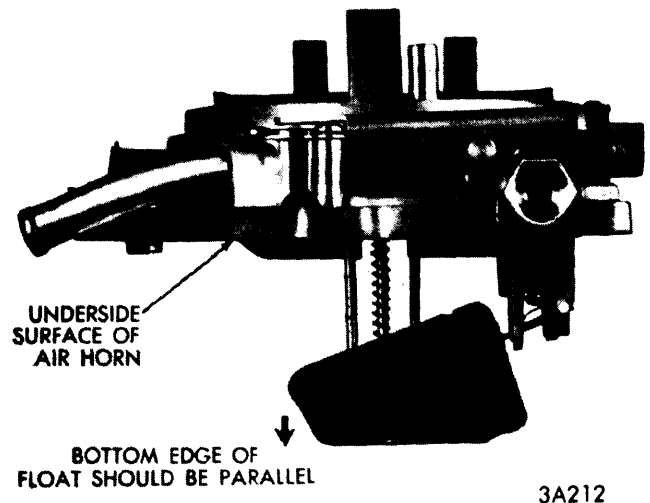

CHECKING FLOAT DROP

---

**HOLLEY 2-BARREL MODEL 2210 (Cont.)**
**OVERHAUL****Disassembly**

With carburetor mounted on elevating legs (so as not to damage throttle valves and provide a suitable working base), remove pump rocker arm from flats on pump shaft, disengage accelerator pump rod from center slot in arm and from hole in throttle lever and proceed as follows:

- 1) Remove nut and washer that attaches choke lever to choke shaft. Disengage fast idle connector rod from lever and fast idle cam. Remove vacuum diaphragm hose from throttle body fitting. Remove choke diaphragm and mounting bracket screws from air horn.
- 2) Remove choke diaphragm, and at the same time, disengage choke operating link from the choke operating lever. Set choke unit aside for separate cleaning. **CAUTION** - A liquid cleaner may damage the diaphragm material. Remove retaining clip that retains bowl vent valve lever on stub shaft on air horn. Slide lever off shaft, being careful not to lose lever spring (note position of spring).
- 3) Remove air horn attaching screws (8) and lift air horn straight up from main body. **CAUTION** - Use extreme care in handling air horn so as not to bend or damage main well tubes.
- 4) Disengage accelerator pump plunger from pump shaft by pushing up on bottom of plunger, then tilting slightly toward center, then slide off pump shaft. Slide plunger stem from air horn and remove compression spring. Slide pump shaft out of air horn.
- 5) Remove fuel inlet fitting and gasket. Invert air horn and remove screw that attaches fuel baffle to air horn. Remove float and fuel inlet needle, then remove needle valve seat.
- 6) Using a special tool (C-4141), remove vacuum power piston. The assembly is staked in position and the staking must be removed, using a suitable sharp tool. **WARNING** - Do not attempt to remove main well tubes from air horn since they are a press fit.
- 7) Remove bowl vent valve cover and remove vent valve, spring and seal. Remove seal from bottom of valve. Remove main metering jets and power valve assembly. Invert main body and drop out accelerator pump discharge check needle from discharge passage.
- 8) Remove fast idle cam from stub shaft. Remove throttle body from main body. Turn idle limiter caps to stop (top on throttle side and bottom of stop on choke side). Remove limiter plastic caps. Count number of turns to seat the screws. Same number of turns (from the seat) must be maintained when carburetor is reassembled. Remove idle mixture screws.

**Cleaning**

- 1) Clean carburetor parts either in denatured alcohol or suitable carburetor cleaning solvent. Avoid placing the plastic parts or diaphragm in ANY liquid. Clean the external surfaces of plastic components and the vacuum diaphragm with a clean cloth or soft brush. Depressing the stem of the diaphragm will afford an additional hole for the removal of dirt. **NOTE** - Compressed air can be used to remove loose dirt but should not be connected to the vacuum diaphragm fitting.
- 2) If a commercial cleaner or solvent recommends the use of water as a rinse, it should be HOT. After rinsing, all traces of water must be blown from the passages with air pressure. It is recommended to further rinse all parts in clean kerosene or gasoline.
- 3) Under no circumstances should jets or orifices be cleaned with a wire or drill. Such a procedure may enlarge the jets or orifices and destroy the factory calibration.

**Reassembly**

Reverse disassembly procedure, using all new gaskets. Note the following:

- 1) If the tapered portion of the idle mixture screws is grooved or ridged, install a new screw. Turn screws lightly against their seat with fingers (DO NOT USE A SCREW-DRIVER). Back off the number of turns (from the seat) counted at disassembly. Install new limiter caps with tab against stop (screws should be equal number of turns on both sides).
- 2) Test freeness of choke mechanism in air horn. Choke shaft must float free in bearing bores.
- 3) When installing vacuum power piston in its cylinder, lock in position by prick punching rim of cylinder in at least three places. Compress piston to be sure no binding exists.
- 4) Before installing air horn, adjust float setting. Invert air horn so that weight of float only is forcing needle against seat. Measure the clearance between top of float and float stop. Clearance should be .200" (#7 drill)(13/64"). Hold air horn in upright position and check float drop. Bottom edge of float should be parallel to underside surface of air horn. Bend tang on float arm to adjust.
- 5) Test the vacuum diaphragm before installing on the air horn. Depress the diaphragm stem, then place finger over the fitting to seal the opening. Release the stem. If the stem moves more than 1/16" in 10 seconds, replace the diaphragm.