

1968-69 ROCHESTER 2GC & 2GV 2-BARREL

1968 MODELS

BUICK	Model	Rochester Carburetor No.	
		Synchro-mesh	Auto. Trans.
350" V8.....	2GV.....	7028141	7028140

CHEVY II, CHEVELLE, & CHEVROLET

307" 200 HP V8			
(No Air Cond.)..	2GV	7028101	7028110
(Air Cond.).....	2GV	7028103	7028112

CAMARO

327" 210 HP V8			
(No Air Cond.)..	2GV	7028101	7028110
(Air Cond.).....	2GV	7028103	7028112

OLDSMOBILE

350" V8			
(No Air Cond.)..	2GC	7028157.....	7028157
(Air Cond.)	2GC	7028156	7028156

400" V8

(No Air Cond.)..	2GC	7028158.....	7028158
(Air Cond.).....	2GC	7028159	7028159

455" V8

(No Air Cond.)..	2GC	7028155.....	7028158
(Air Cond.).....	2GC	7028159	7028159

PONTIAC & TEMPEST

350" V8.....	2GV	7028071	7028062
400" V8.....	2GV	7028066	7028060

1969 MODELS

BUICK	Model	Rochester Carburetor No.	
		Synchro-mesh	Auto. Trans.
350" V8.....	2GV.....	7029141	7029140

CHEVY NOVA, CHEVELLE

307" 200 HP V8	2GV 1/4	7029101	7029110
(with Air Cond.)..	2GV 1/4	7029103	7029112
350" 255 HP V8.....	2GV 1/2	7029113	7029114
(with Air Cond.)..	2GV 1/2	7029115	7029116

CAMARO

327" 210 HP V8.....	2GV 1/4	7029127	7029110
(with Air Cond.)..	2GV 1/4	7029129	7029112
350" 255 HP V8.....	2GV 1/2	7029113	7029114
(with Air Cond.)..	2GV 1/2	7029115	7029116

CHEVROLET

307" 200 HP V8.....	2GV 1/4	7029101	7029110
(with Air Cond.)..	2GV 1/4	7029103	7029112
327" 235 HP V8.....	2GV 1/2	7029102	7029102
(with Air Cond.)..	2GV 1/2	7029104	7029104
350" 255 HP V8.....	2GV 1/2	7029113	7029114
(with Air Cond.)..	2GV 1/2	7029115	7029116
396" 265 HP V8.....	2GV 1/2	7029117	7029118
(with Air Cond.)..	2GV 1/2	7029119	7029120

OLDSMOBILE

350" V8.....	2GC	7029155.....	7029156
400 & 455" V8.....	2GC	7029158.....	7029158
(with Air Cond.)..	2GC	7029159	7029159

PONTIAC, TEMPEST, FIREBIRD

350" V8.....	2GV	7028071	7029062
400" V8.....	2GV	7028066	7029060

► CHANGES, CAUTIONS, CORRECTIONS

► **C.C.S." & "A.I.R." ENGINES NOTE:** These engines have special exhaust emission controls as follows: Specially calibrated distributors and carburetors, closed positive crankcase ventilation system, and related control units. **C.C.S. Engines** - Have "thermo air cleaner" (vacuum powered, thermostatically controlled cleaner air intake for control of carburetor air temperature). **A.I.R. Engines (Chevrolet Synchro-mesh)** - Air pump used for air injection in engine at exhaust valve ports.

► **1968 TEMPEST & FIREBIRD 350" V8 & 400" GTO V8, & PONTIAC 400" V8 CORRECTION FOR IRREGULAR EXHAUST NOISE, ROUGH IDLE OR DOWNSHIFT CLUNK ON 2-SPEED AUTOMATIC TRANSMISSIONS (Automatic Trans. Cars Before 10/10/67):** Production change listed below for these engines will eliminate this complaint on later cars. Rework vacuum system and change idle speed setting as follows:

1) Remove yellow-stripe hose from carburetor port to TVS and vacuum hose from TVS to retard port on distributor vacuum unit and discard these hoses (do not remove steel hose fittings from TVS). Cap these two fittings using No. 9781338 Caps or connect tubes with short piece of discarded hose to exclude foreign particles from TVS. Cap open port on carburetor with same type cap but DO NOT cap port on distributor vacuum unit. Check and adjust ignition timing.

2) Set idle speed to revised increased RPM: **Solenoid Active Idle Speed in Drive** - 650 RPM (was 600 RPM), **Solenoid Inactive Idle Speed** - 575 RPM (Was 500 RPM).

► **1968 TEMPEST & FIREBIRD 350" V8 & 400" GTO V8, & PONTIAC 400" V8 SPARK RETARD & IDLE SPEED PRODUCTION CHANGE (Engines with Automatic Transmission Only):** At approximately 10/10/67, the following changes were made to improve idle, reduce exhaust noise, and eliminate downshift clunk on two-speed automatic transmissions:

1) Vacuum hoses from carburetor port below throttle valves to TVS and from TVS to retard side of distributor vacuum unit were eliminated (this eliminates timing retard action at idle).

2) Engine idle speed was increased as follows: **Solenoid Active Idle Speed in Drive** - 650 RPM (was 600 RPM), **Solenoid Inactive Idle Speed** - 575 RPM (was 500 RPM).

NOTE - Revised engines will have new decal listing these revised idle speeds.

► **1968 PONTIAC & TEMPEST V8 ENGINES IDLE STOP SOLENOID BRACKET MISPOSITION CORRECTION:** If idle stopscrew cannot be adjusted out sufficiently for correct "solenoid active" idle speed setting, loosen left front carburetor-to-manifold nut, position solenoid bracket properly and hold bracket in this position while tightening nut to 15 ft. lbs. torque.

CARBURETOR IDENTIFICATION

Rochester carburetor number is stamped on upper part of tag attached to carburetor. A letter ("A", "B", etc.) stamped in box on lower left corner of tag indicates successive engineering changes or modifications made in production (each succeeding letter indicates all previous modifications are also included).

1968-69 ROCHESTER 2GC & 2GV 2-BARREL (Continued)

DESCRIPTION

2-Barrel downdraft types with manual choke (2G), integral automatic choke (2GC), and separate "well" type automatic choke (2GV Carburetors). All carburetors have a Vacuum Break assembly. Some carburetors have plastic cellular floats and require special Float Level and Float Drop settings (see Adjustments).

Adjustable Part Throttle (A.P.T.) Feature (Chevrolet Carburetors 1968) - Consists of a tapered metering screw located in channel on bottom of float bowl which controls supplementary fuel for main metering system. *This adjustment is set at factory and sealed. CAUTION - No attempt should be made to adjust this screw or change setting in the field.*

Adjustable Off - Idle Feature (1968 Buick, Oldsmobile, Pontiac & Tempest Carburetors) - Consists of an adjusting screw on side of carburetor controlling an air passage for off-idle fuel mixture adjustment. *This adjustment is set at factory and sealed. CAUTION - This adjustment cannot be made in the field.*

Idle Stop Solenoid - Used on some carburetors. Consists of a solenoid controlled throttle stopscrew mechanism connected in ignition circuit which controls idle speed with engine running. When ignition turned off, solenoid allows throttle valves to close further as determined by conventional throttle stopscrew setting. Carburetors with idle stop solenoid require special idle speed adjustment. See Adjustments.

ADJUSTMENT

If initial adjustment required to warm up engine, set each idle mixture screw 2 turns out (Buick), 1½ turns out (1968 Chevrolet), 3 turns out (1969 Chevrolet), 1½ turns out (Oldsmobile), 4 turns out (Pontiac) from a lightly seated position. On cars with Idle Stop Solenoid, check solenoid position as follows:

Idle Stop Solenoid Position - With throttle stopscrew set for approximately 575 RPM idle speed (normal setting), loosen clampscrew and slide solenoid away from throttle lever. Energize solenoid (or hold solenoid plunger in outer extended position), adjust solenoid stopscrew so that head of screw is $7/8" \pm 1/16"$ out of solenoid body (see illustration), move solenoid assembly inward until screw lightly contacts throttle lever, make certain electrical connection is positioned 90° inward and tighten solenoid clampscrew. Back off throttle stopscrew so that throttle valves are completely closed.

Idle Speed & Mixture

Engine must be idling at normal operating temperature with choke valve wide open and fast idle inoperative. With Auto. Trans. in Drive, Air Conditioner OFF, idle stop solenoid energized (normal running condition) and Hot Idle Compensator Valve closed (where used), adjust each model as directed below.

Buick - Disconnect vacuum hose at distributor and plug hose (to prevent vacuum switch operation and resultant distributor advance). Adjust throttle stopscrew for correct hot engine idle (see Specifications), adjust both idle mixture screws for highest engine RPM, then readjust throttle stopscrew for 20 RPM higher than the specified idle speed, finally turn each idle mixture screw in (to lean mixture) until engine speed drops off 10 RPM (total of 20 RPM for both screws) so that engine speed is at specified RPM.

Chevrolet - Adjust throttle stopscrew for specified hot engine idle RPM (see Specifications), adjust both idle mixture screws evenly for highest steady idle speed, then readjust throttle stopscrew for specified idle speed. Turn each idle mixture screw in evenly until engine speed decreases 20 RPM (lean roll point), finally turn screw out 1/4 turn. Recheck idle speed and readjust if necessary.

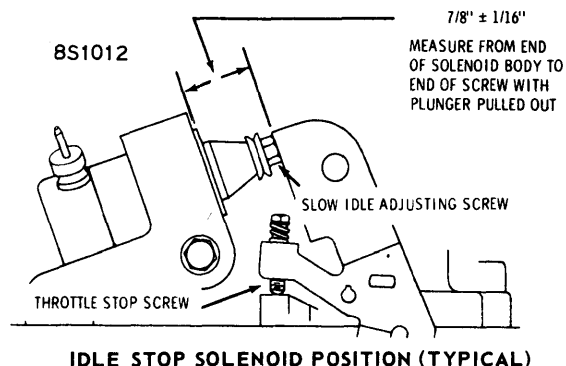

Oldsmobile - Remove air cleaner, disconnect air cleaner vacuum hose at intake manifold and plug manifold fitting. Disconnect vacuum hose at distributor and plug end of hose. 1) Adjust idle stop solenoid stopscrew (where used) or throttle stopscrew and both idle mixture adjusting screws alternately for best idle at specified hot engine idle RPM (see Specifications), then turn each idle mixture screw in for 10-15 RPM drop in engine speed (total drop of 20-30 RPM for both screws).

2) On carburetors with idle stop solenoid, disconnect lead at solenoid (throttle lever will seat against regular stopscrew), adjust this stopscrew for idle speed of 400 RPM.

3) Recheck idle speed with air cleaner installed.

Pontiac, Tempest & Firebird - Adjust throttle stopscrew for specified hot engine idle RPM (see Specifications), adjust both idle mixture screws evenly by turning screws in to lean mixture for best lean carburetor setting. Recheck idle speed. If necessary to readjust idle speed, repeat idle mixture adjustment.

Fast Idle Speed
(On Engine)

NOTE - Separate fast idle speed adjustment is not required except on cars listed below. On all other cars, fast idle speed will be correct when hot or slow idle speed is correctly adjusted.

Oldsmobile Models - Perform all preliminary operations as detailed for Idle Speed & Mixture Adjustment (above). With engine at normal operating temperature and idling with transmission in Neutral (Synchro-mesh), Park (Auto. Trans.) position fast idle adjusting screw on low step of fast idle cam and against shoulder of second step, turn fast idle screw in or out for engine speed of 900 RPM.

Slow-Closing Throttle
Dashpot

See CARBURETOR on car model Tune-Up pages for adjustment of this unit (when used).

Throttle Linkage
(Auto. Trans. Cars)

See CARBURETOR on car model Tune-Up pages.

1968-69 ROCHESTER 2GC & 2GV 2-BARREL (Continued)

CARBURETOR ADJUSTMENT SPECIFICATIONS									
Rochester Carb. No.	Hot Idle Speed (Engine RPM) ①		Float Level Setting	Float Drop Setting	Pump Rod Setting	Idle Vent Setting	Choke Rod Setting	Unloader Setting	Auto. Choke Setting
	Synchro-mesh	Auto. Trans.							
7028060	-	650 ②⑥	9/16"	1 3/4"	1 11/32"	-	.085"	.180"	③
7028062	-	650 ②⑥	9/16"	1 3/4"	1 11/32"	-	.085"	.180"	③
7028066	800 ②	-	9/16"	1 3/4"	1 11/32"	-	.085"	.180"	③
7028071	700 ②	-	9/16"	1 3/4"	1 11/32"	-	.085"	.180"	③
7028101	700	-	3/4"	1 3/4"	1 1/8"	.025"	.060"	.200"	④
7028103	700	-	3/4"	1 3/4"	1 1/8"	.025"	.060"	.200"	④
7028110	-	600 ⑤	3/4"	1 3/4"	1 1/8"	.025"	.060"	.200"	④
7028112	-	600 ⑤	3/4"	1 3/4"	1 1/8"	.025"	.060"	.200"	④
7028140	-	550	15/32"	1 9/32"	1 11/32"	.025"	.050"	.140"	③
7028141	700	-	15/32"	1 9/32"	1 11/32"	.025"	.050"	.140"	③
7028155	675 ②	-	9/16"	1 3/8"	1 7/16"	.025"	.150"	.160"	1 Lean Index
7028156	675 ②	575 ②	9/16"	1 3/8"	1 7/16"	.025"	.150"	.160"	Index
7028157	675 ②	575 ②	9/16"	1 3/8"	1 7/16"	.025"	.150"	.160"	Index
7028158	-	575 ②	9/16"	1 3/8"	1 7/16"	.025"	.150"	.160"	Index
7028159	675 ②	575 ②	9/16"	1 3/8"	1 7/16"	.025"	.150"	.160"	Index
7029101	700	-	27/32"	1 3/4"	1 1/8"	.020"	.060"	.215"	④
7029102	-	600	3/4"	1 3/4"	1 13/32"	.020"	.085"	.275"	④
7029103	700	-	27/32"	1 3/4"	1 1/8"	.020"	.060"	.215"	④
7029104	-	600	3/4"	1 3/4"	1 13/32"	.020"	.085"	.275"	④
7029110	-	600	27/32"	1 3/4"	1 1/8"	.020"	.060"	.215"	④
7029112	-	600	27/32"	1 3/4"	1 1/8"	.020"	.060"	.215"	④
7029113	700	-	3/4"	1 3/4"	1 13/32"	.020"	.085"	.275"	④
7029114	-	600	3/4"	1 3/4"	1 13/32"	.020"	.085"	.275"	④
7029115	700	-	3/4"	1 3/4"	1 13/32"	.020"	.085"	.275"	④
7029116	-	600	3/4"	1 3/4"	1 13/32"	.020"	.085"	.275"	④
7029117	700	-	3/4"	1 3/4"	1 13/32"	.020"	.085"	.275"	④
7029118	-	600	3/4"	1 3/4"	1 13/32"	.020"	.085"	.275"	④
7029119	700	-	5/8"	1 3/4"	1 13/32"	.020"	.085"	.275"	④
7029120	-	600	5/8"	1 3/4"	1 13/32"	.020"	.085"	.275"	④
7029127	700	-	3/4"	1 3/4"	1 13/32"	.020"	.085"	.275"	④
7029129	700	-	3/4"	1 3/4"	1 13/32"	.020"	.085"	.275"	④
7029140	-	600	15/32"	1 7/32"	1 11/32"	.020"	.050"	.140"	③
7029141	700	-	15/32"	1 7/32"	1 11/32"	.020"	.050"	.140"	③
7029155	675 ②	-	9/16"	1 3/8"	1 7/16"	.025"	.140"	.170"	1 Lean Index
7029156	-	575 ②	9/16"	1 3/8"	1 7/16"	.025"	.140"	.170"	Index
7029158	675 ②	575 ②	9/16"	1 3/8"	1 7/16"	.025"	.140"	.170"	Index
7029159	675 ②	575 ②	9/16"	1 3/8"	1 7/16"	.025"	.140"	.170"	Index
7028066	850	-	9/16"	1 3/4"	1 11/32"	-	.085"	.180"	③
7028071	850	-	9/16"	1 3/4"	1 11/32"	-	.085"	.180"	③
7029060	-	650	9/16"	1 3/4"	1 11/32"	-	.085"	.180"	③
7029062	-	650	9/16"	1 3/4"	1 11/32"	-	.085"	.180"	③

- ① - Auto. Trans. in DRIVE, Air Cond. OFF (except as noted).
- ② - Idle Stop Solenoid setting (see Text for throttle stopscrew setting).
- ③ - Gauging notch on lever (see text for adjustment procedure).
- ④ - Interference fit of rod (see text for adjustment procedure).
- ⑤ - On 307" Non-Emission Control (Export) Engines, set idle speed at 500 RPM on all transmissions.
- ⑥ - Revised specification. See "Changes, Cautions, Corrections".

Rochester Carburetors

1968-69 ROCHESTER 2GC & 2GV 2-BARREL (Continued)

Float Level (Metal Floats)

Invert air horn assembly with gasket in place, measure from face of gasket to lower (sharp) edge of float seam at free end of float (see illustration). If this distance not correct (see Specifications), adjust by bending float arm as shown.

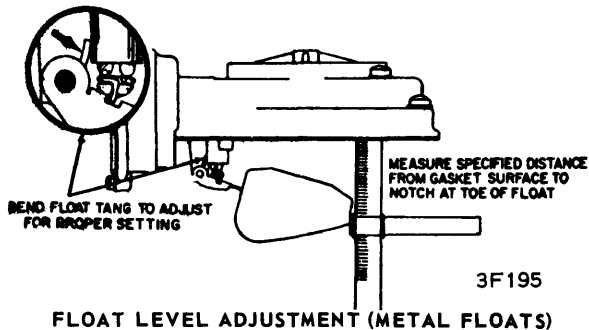

FLOAT LEVEL ADJUSTMENT (METAL FLOATS)

Float Drop (Metal Floats)

Hold air horn assembly upright (gasket in place), and measure distance from gasket to bottom of float pontoon (see illustration). Distance should be as indicated in specifications. To adjust, bend tang on float.

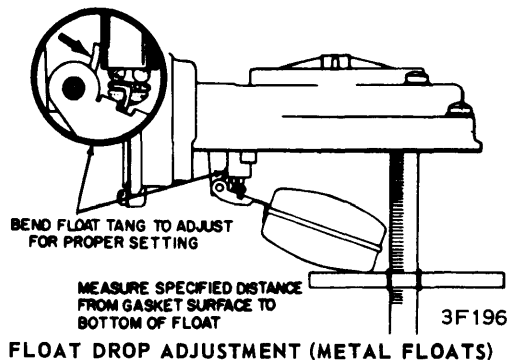

FLOAT DROP ADJUSTMENT (METAL FLOATS)

Float Level (Plastic Floats)

Invert air horn assembly with gasket in place, measure distance from gasket face to lip on free end of float (see illustration). If this distance not correct (see Specifications), adjust by bending float arm as shown.

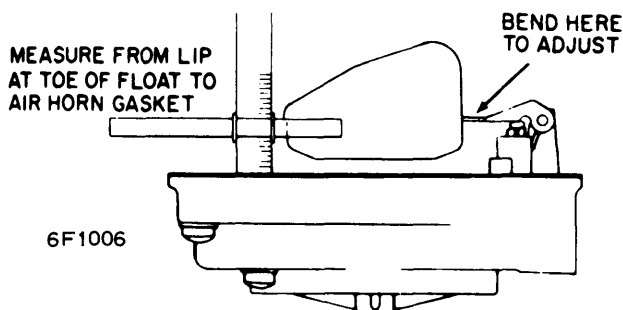

FLOAT LEVEL ADJUSTMENT (PLASTIC FLOATS)

Float Drop (Plastic Floats)

With air horn gasket in place, hold air horn upright and measure distance from gasket face to notch on free end of

float (see illustration). If this distance not correct (see Specifications), adjust by bending float arm tang as shown.

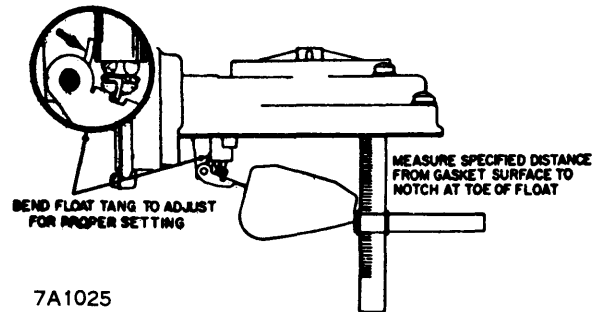

FLOAT DROP ADJUSTMENT (PLASTIC FLOATS)

Accelerating Pump

With throttle stopscrew and fast idle screw (when used) backed out so that throttle valves are completely closed, measure distance from top of air horn ring to top of pump connector rod at pump lever (see illustration). If this distance not correct (see Specifications), adjust by bending pump connector rod at the angle.

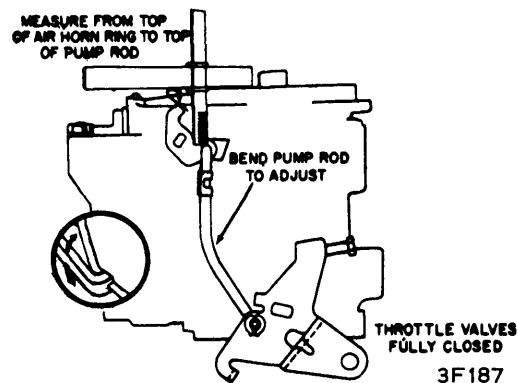

ACCELERATING PUMP ADJUSTMENT

Idle Vent

NOTE - Idle vent is not used on all carburetor models. New procedure below is required for proper emission control. On cars with idle stop solenoid, solenoid must be energized (ignition on) when checking and adjusting idle vent. After idle speed and mixture adjustment completed and with throttle valves closed in curb idle position (idle stop solenoid energized), use feeler gauge to measure vent valve opening or clearance between lower face of valve and air horn at widest opening point. If clearance not correct (see Specifications), adjust by bending actuating tang on pump lever as required.

Intermediate Choke Rod (Oldsmobile)

Remove choke thermostatic cover and coil assembly, and baffle plate. Place fast idle screw on highest step of fast idle cam. Completely close choke valve by pushing clockwise on choke coil lever in choke housing. With choke valve closed, the right side of lever should be parallel and even with left side of index mark on choke housing. To adjust bend choke rod. Replace inside baffle plate, cover and coil assembly.

1968-69 ROCHESTER 2GC & 2GV 2-BARREL (Continued)

1968 Oldsmobile - NOTE - There are three holes in upper choke lever and adjustment below should be made with intermediate choke rod connected in CENTER hole. See Note below for "tailoring" choke setting. With choke thermostat cover, coil assembly, and inner baffle plate removed, open throttle valve and hold choke valve completely closed by pushing up on intermediate choke lever (see illustration). Choke piston should be flush with end of cylinder or extend out of cylinder as specified in table below. Adjust by bending intermediate choke rod.

OLDSMOBILE CHOKE SETTING "TAILORING" FOR CLIMATIC & TEMPERATURE CONDITIONS: - Moving intermediate choke rod to next OUTER hole (away from choke shaft) will provide richer mixture during warm-up for acceleration and load, moving intermediate rod to next INNER hole will provide leaner mixture under same operating conditions.

Car & Carburetor	Choke Piston Position
Oldsmobile 7028155	Flush
7028156, 7028157	1st. Groove
7028158, 7028159	Flush

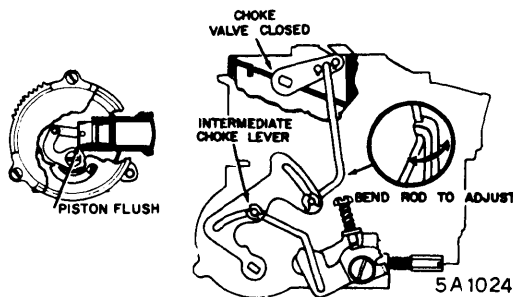

INTERMEDIATE CHOKE ROD ADJUSTMENT (OLDSMOBILE)

Vacuum Break (2GV Carbs.)

Press in on diaphragm plunger so that diaphragm is bottomed in housing and make certain choke valve is closed so that connecting rod is at end of slot in choke lever. Measure clearance between edge of choke valve and air horn wall (see table below). Adjust by bending connector rod (see illustration).

Car & Carburetor	Vacuum Break Setting	Choke Valve Clearance
Buick		
7028140, 41120"
7029140, 41110"
Chevrolet		
7028101, 3, 10, 12100"
7029101, 3, 10, 12100"
7029102, 4, 17, 18, 19, 20, 27, 29215"
7029113, 14, 15, 16200"
Pontiac & Tempest		
7028060, 62150"
7028066170"
7028071160"

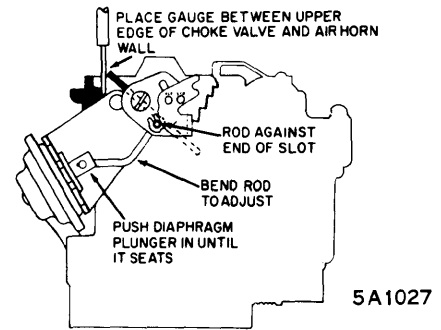

VACUUM BREAK ADJUSTMENT

Vacuum Break (Oldsmobile 2GC)

Seat vacuum break plunger and diaphragm (use vacuum source) and make sure choke valve is closed so connecting rod is in end of slot in diaphragm plunger stem. In this position bend vacuum break rod until specified gauge will just pass between upper edge of choke valve and inside air horn wall.

Car & Carburetor	Vacuum Break Setting	Choke Valve Clearance
Oldsmobile 7029155,6,8,9180"

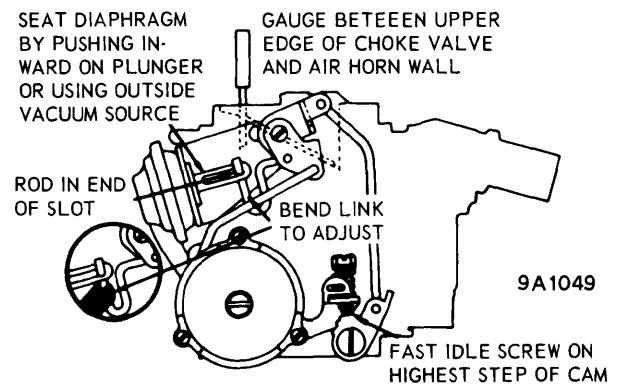

VACUUM BREAK ADJUSTMENT (OLDSMOBILE)

Choke Rod

All Models (Except Oldsmobile) - Position throttle stop-screw on second step of the fast idle cam and against shoulder of high step. Choke valve opening or clearance between upper edge of valve and air horn wall should be correct as shown in "Specifications". Adjust by bending tang on choke shaft lever and collar assembly (see illustration).

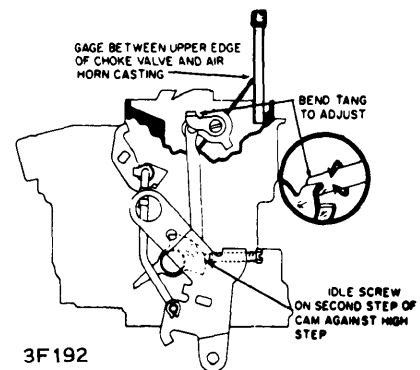

CHOKE ROD ADJUSTMENT (EXCEPT OLDSMOBILE)

Rochester Carburetors

1968-69 ROCHESTER 2GC & 2GV 2-BARREL (Continued)

Oldsmobile Models - Position fast idle adjusting screw on second step of fast idle cam and against shoulder of high step. Make certain that intermediate choke rod and choke rod are at ends of slots in intermediate choke lever by pushing upward on lever (see illustration). Choke valve opening or clearance between upper edge of valve and air horn wall should be correct as shown in "Specifications". Adjust by bending choke rod.

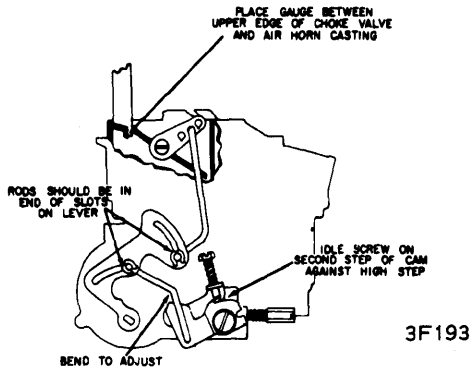

CHOKE ROD ADJUSTMENT (OLDSMOBILE)

Unloader

With throttle valves held wide open, distance between upper edge of choke valve and wall of air horn should be as indicated in specification table. To adjust, bend tang on throttle lever (Exc. Oldsmobile); bend tang on fast idle cam by inserting screw driver in slot in lever.

Automatic Choke (Oldsmobile 2GC)

Loosen three retaining screws on thermostat cover, then rotate cover until index mark is in alignment with correct mark on housing as indicated in specification table. Tighten cover retaining screws.

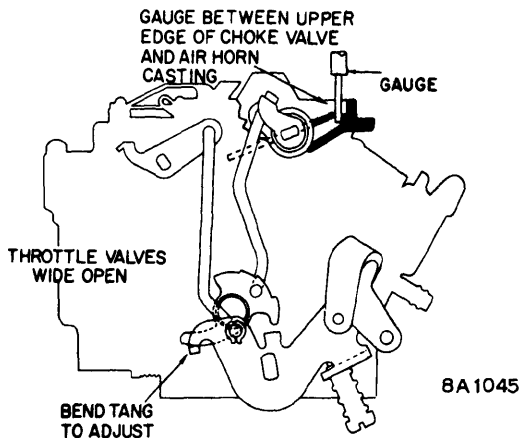

UNLOADER ADJUSTMENT (EXCEPT OLDSMOBILE)

Automatic Choke (2GV Carbs.)

Disconnect choke rod at choke valve lever, hold choke valve closed and check choke rod length for each car model as detailed below. Adjust by bending rod at offset bend. **CAUTION** - When reconnecting rod, make certain rod end enters lever hole freely without bind.

Buick - Pull upward on choke rod to limit of travel. Rod end should fit freely in gauging notch on lever. After adjustment, install rod end in lower hole in lever (lever has two holes).

Chevrolet - Press downward on rod to limit of travel. Bottom of rod end should be even with bottom of hole in choke lever (1 rod diameter interference fit).

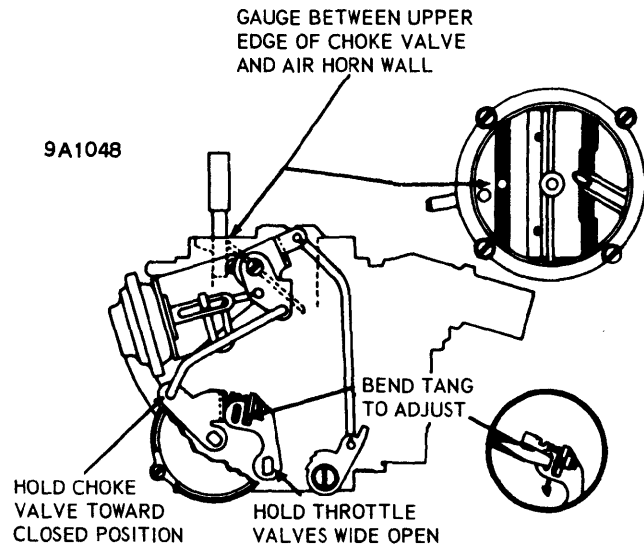

UNLOADER ADJUSTMENT (OLDSMOBILE)

Pontiac & Tempest - Pull upward on choke rod to limit of travel. Rod end should fit freely in gauging notch on lever.

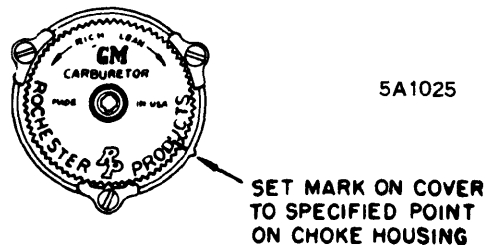

AUTOMATIC CHOKE ADJUSTMENT (2GC)

Rochester Carburetors

7-119

1968-69 ROCHESTER 2GC, 2GV 2-BARREL (Continued)

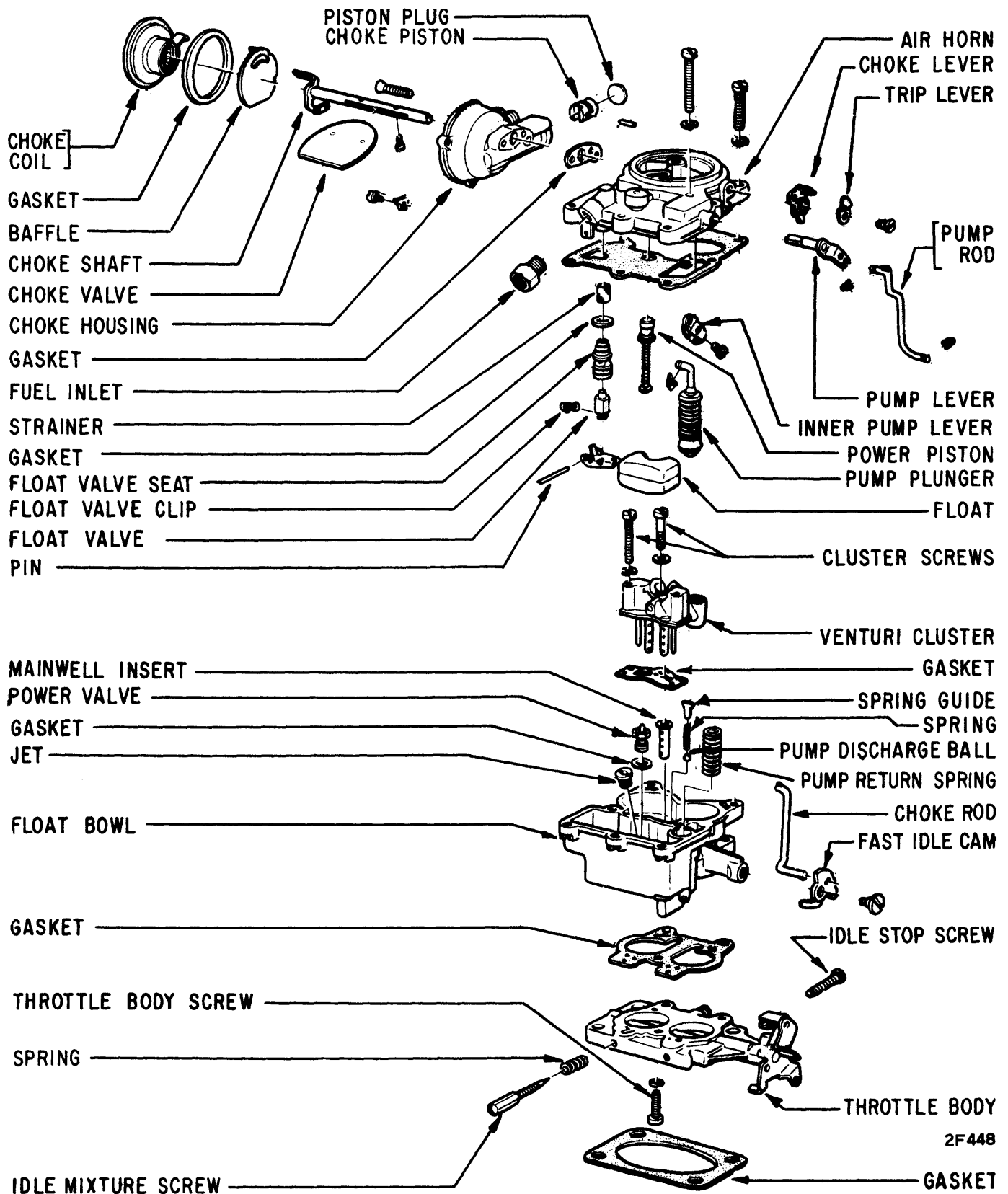

ROCHESTER 2GC 2-BARREL CARBURETOR (AUTOMATIC CHOKE ON AIR HORN)

1968-69 ROCHESTER 2GC & 2GV 2-BARREL (Continued)

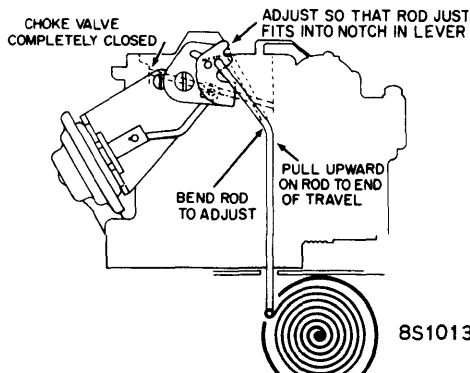

AUTOMATIC CHOKE ADJUSTMENT (2GV)
(EXCEPT CHEVROLET)

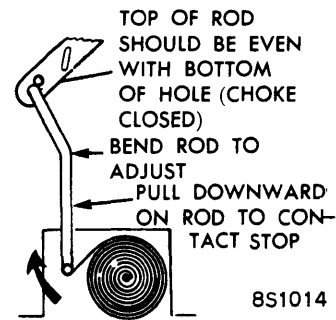

AUTOMATIC CHOKE ADJUSTMENT (2GV)
(CHEVROLET)

OVERHAUL

Disassembly

Air Horn - Remove fuel inlet fitting, gasket and screen. Remove retaining screw and vent valve and shield. Remove pump rod and choke intermediate rod, then remove choke trip lever and fast idle link and lever. **CAUTION** - If fast idle link retained by Truarc washer, do not disconnect link from cam. Remove attaching screws, separate air horn from main body, then remove float and needle valve assembly. Disconnect intake needle valve from float. Remove intake needle seat and gasket, and remove filter from needle seat bore. Remove power piston by depressing stem and allowing it to snap free (or hold stem and tap lightly on air horn). Remove pump plunger assembly from pump arm, then loosen setscrew on pump inner arm and remove pump outer lever and shaft. On all Carburetors, take out screw in end of choke shaft and disengage vacuum break lever from shaft (allow lever to hang on diaphragm rod), take out diaphragm mounting screws and remove vacuum break diaphragm assembly. If necessary to replace choke valve or shaft, remove choke valve screws, lift valve out, slide choke shaft from air horn.

Main Body (Float Bowl) - Remove pump return spring from pump cylinder, remove pump inlet filter screen and inlet check ball (if used). On carburetors with idle compensator valve, take out attaching screws and remove idle compensator and gasket. Remove main metering jets and power valve. Take out venturi cluster retaining screws and lift out venturi cluster, gasket, and separate main well inserts (if used). **CAUTION** - Do not attempt to disassemble cluster. Use needle nose pliers to lift out pump discharge spring guide, remove spring and pump discharge check ball. Invert float bowl assembly, remove three throttle body attaching screws, lift off throttle body and gasket.

Throttle Body - On carburetors with automatic choke mounted on throttle body, see Automatic Choke data below for disassembly of automatic choke. On all models, remove fast idle retaining screw and remove fast idle cam and link assembly. Remove idle mixture adjusting screws and springs. Do not disassemble throttle body further. **Throttle body is serviced as an assembly with throttle valves and shaft.**

Automatic Choke (Type mounted on Throttle Body) - Take out three choke cover attaching screws and retainers, remove choke cover and thermostatic coil assembly, cover gasket, and baffle plate. Remove two choke housing attaching screws, remove choke housing from throttle body, remove and discard housing gasket. Remove choke lever and shaft from choke housing. Remove dust seal from choke housing.

Cleaning & Inspection

Clean all carburetor castings and metal parts in cleaning solvent. Do not immerse choke housing and coil assembly, pump plunger, or vacuum break diaphragm in cleaning solvent. Clean pump plunger in clean gasoline, clean vacuum break diaphragm by wiping with clean cloth. Blow out all passages with compressed air. Inspect all parts for wear or damage and replace as necessary.

Reassembly

Use all new gaskets. Reassemble carburetor by reversing disassembly procedure and note the following:

Choke Valve Installation - Install valve with identifying mark "RP" upward, center choke valve before tightening screws (**NOTE** - Valve can be centered by installing fast idle lever and choke trip lever on end of shaft and maintaining .020" clearance between fast idle lever and air horn casting, or between choke trip lever and choke lever and collar assembly). Stake choke valve screws lightly after tightening. Choke valve should move freely in housing.

Accelerating Pump Assembly - Lubricate pump shaft with Lubriplate or light grease when installing in bowl cover. Make certain that pump check balls are not interchanged. Inlet check ball is Aluminum, discharge check ball is steel. **NOTE** - No inlet check ball is used in Chevrolet 2GV carburetors (fuel inlet is through 2-piece pump plunger assembly).

Venturi Cluster Installation - Center cluster screw must have gasket (to prevent pump discharge leakage around screw). Tighten all cluster screws evenly.

Power Piston Installation - Make certain piston travels freely in its cylinder. Stake retainer washer lightly to retain assembly in place.

1968-69 ROCHESTER 2GC & 2GV 2-BARREL (Continued)

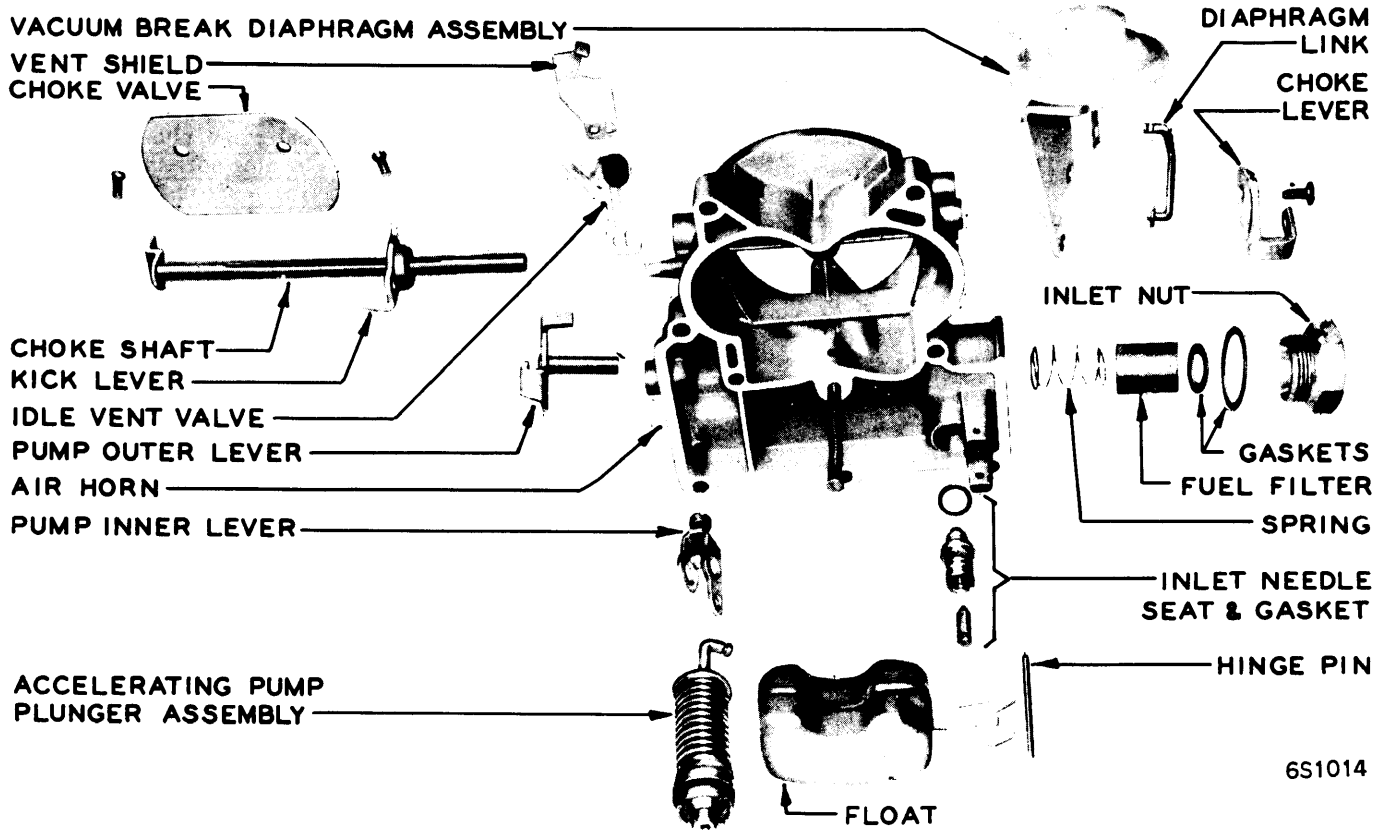

ROCHESTER 2GV 2-BARREL CARBURETOR AIR HORN ASSEMBLY