

1968-69 CORVETTE HOLLEY TRIPLE CARBURETORS

		1968		Holley Carburetor No.	
CORVETTE	Model	Synchro-mesh	Auto. Trans.		
427" 400 HP V8					
Primary	2300C	R45055A, 1A
Secondary (2)	2300	R3659A
				R4056A, 1A
427" 435 HP V8					
Primary	2300C	R4055A, 1A
Secondary (2)	2300	R3659A

		1969		Holley Carburetor No.	
CORVETTE	Model	Synchro-mesh	Auto. Trans.		
427" 400 & 435 HP V8					
Primary	2300C	R-4055-1A
Secondary (2)	2300	R-3659A
				R-4056-1A
				R-3659A

►CHANGES, CAUTIONS, CORRECTIONS

►1968 427" 400 HP V8 ENGINE IDLE SPEED AND MIXTURE PROCEDURE CORRECTION (With Synchro-mesh & Air Cond. ONLY): 1) Turn air conditioner ON and leave air cleaner on. Adjust idle stop solenoid screw to give 1,000 RPM then adjust idle mixture adjusting screw for highest steady idle speed and readjust idle stop solenoid for specified idle speed. Turn idle mixture screw in (to lean mixture) until speed drops off exactly 20 RPM to give lean roll point. Finally turn idle mixture screw out exactly ¼ turn.

2) Disconnect lead at idle stop solenoid (throttle lever will seat against regular stopscrew), adjust this stopscrew for idle speed of 500 RPM. Do not change setting of idle stop solenoid stopscrew or idle mixture screws.

TRIPLE CARBURETOR INSTALLATION

Center (primary) and two end (secondary) carburetors are mounted on a common intake manifold. Primary carburetor throttle actuation is conventional with throttle valve lever linked to accelerator pedal. Secondary carburetor throttles are actuated by vacuum diaphragm housing assemblies which are controlled by the primary carburetor.

DESCRIPTION

Model 2300C (Primary Carburetor) – Two barrel downdraft carburetor of same design as previous Holley carburetors. Automatic choke is separate well type and carburetor has vacuum break diaphragm unit to provide initial choke opening. NOTE – “-1A” Carburetors have an idle vent.

Model 2300 (Secondary Carburetors) – These carburetors are similar in design to primary carburetor except that no choke valve, power enrichment system, or accelerating pump are used and these adjustments are not required.

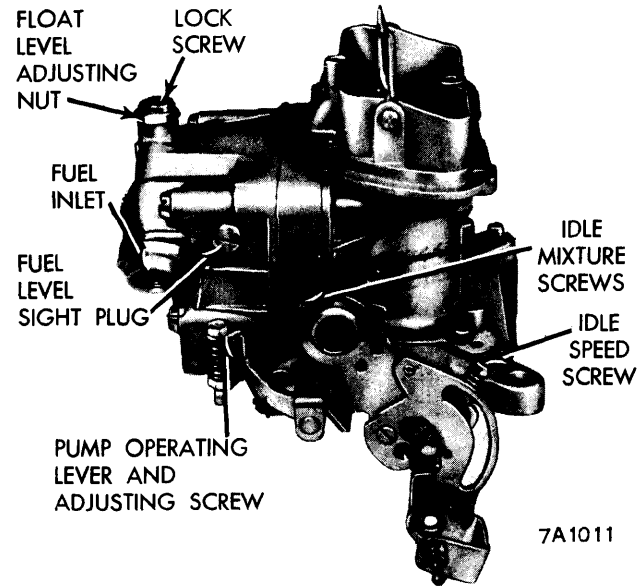

PRIMARY CARBURETOR (2300C)

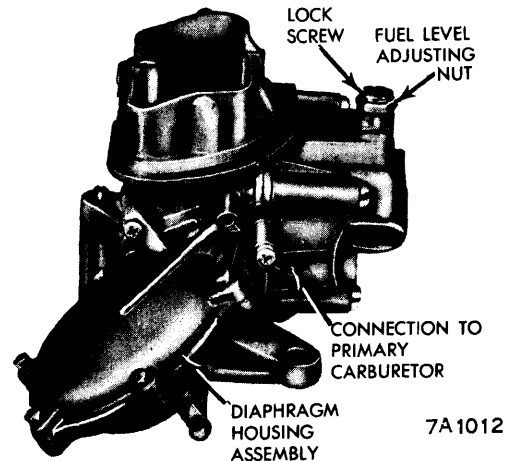

SECONDARY CARBURETOR (2300)

ADJUSTMENT

►ADJUSTMENT NOTE – For idle speed and mixture adjustment, place automatic transmission selector in Drive, Air conditioner OFF, except on 1969 427" 400 HP V8, set idle speed with air conditioner ON.

Idle Speed & Mixture

►1968 427" 400 HP ENGINE ADJUSTMENT NOTE – Later carburetors have idle stop solenoid. See “Changes, Cautions, Corrections” for idle speed adjustment procedure.

With engine at normal operating temperature and choke valve wide open, adjust idle speed screw for correct hot engine idle speed (see specifications), adjust idle mixture screw for highest steady idle speed, readjust idle speed screw for correct engine idle RPM, then turn mixture screw in until engine speed drops off 20 RPM (lean point roll), finally turn screw out exactly ¼ turn. Adjust second idle mixture screw in same manner. Readjust idle speed screw as required for specified idle speed. NOTE – Adjust idle speed for 1969 427" 435 HP V8 with idle solenoid as follows: Adjust idle speed to specifications by adjusting solenoid plunger hex only. Disconnect wire at solenoid and observe idle speed. De-energizing the solenoid allows throttle lever to seat against carburetor idle screw. Adjust carburetor idle screw as necessary to obtain 400 RPM.

1968-69 CORVETTE HOLLEY TRIPLE CARBURETORS (Continued)

Fast Idle Speed (On Engine)

With engine at normal operating temperature and idling, position fast idle lever on high step of fast idle cam, bend lever tang as necessary for correct fast idle speed (See Specifications).

Fuel Level (On Engine)

With car on level surface and engine idling, remove fuel level sight plug on side of float bowl. Fuel level should be even with threads at bottom of sight plug hole (plus or minus $1/32$ "). **NOTE** - When checking secondary carburetor fuel level, primary throttle valves should be opened slightly and secondary carburetor throttle hand operated to assure stabilized fuel level in secondary float bowl. To adjust fuel level, loosen lock screw on adjustable intake needle seat assembly, turn adjusting nut clockwise to lower fuel level or counterclockwise to raise fuel level ($1/6$ turn of adjusting nut will change fuel level approximately $1/16$ "), tighten lock screw. Allow one minute for fuel level to stabilize, then recheck fuel level and re-adjust as necessary.

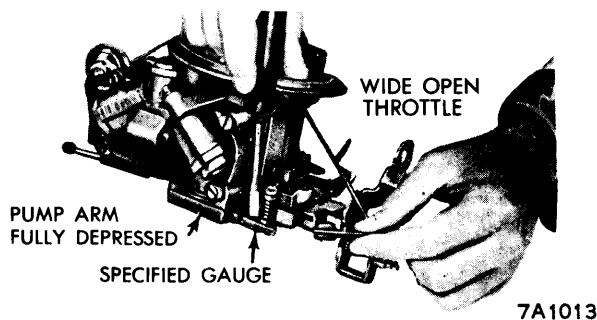

ACCELERATING PUMP ADJUSTMENT

Bowl Idle Vent

With throttle valves fully closed, check clearance between vent valve button and seat on bowl cover. This clearance should be $.085$ ". Adjust by bending vent valve rod at lower end near throttle lever.

Accelerating Pump (Primary Carb.)

Hold throttle lever in wide open position, fully compress pump lever (press lever down), measure clearance between face of adjusting nut on pump operating lever and contact surface on pump lever. This clearance should be $.015$ " (all carburetors). Adjust by turning adjusting screw in or out while holding adjusting nut. Check setting by closing throttle valves and noting pump lever action as throttle is opened. Any movement of throttle lever should be noted at operating lever adjusting screw end without lost motion.

Vacuum Break (Primary Carburetor)

Hold vacuum break stem in against stop, close choke valve by pressing on intermediate choke lever so that vacuum break connector rod is at end of slot in lever, measure choke valve opening by inserting drill rod or gauge of correct size (see Specifications) between lower edge of valve and air horn wall. If this opening not correct, adjust by bending vacuum break connector rod as necessary.

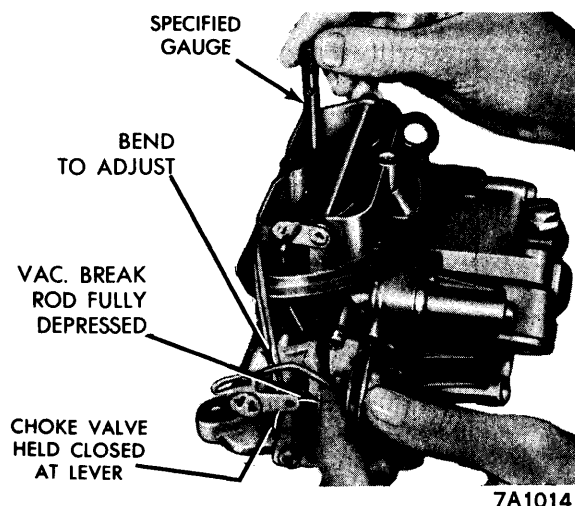

VACUUM BREAK ADJUSTMENT

Unloader (Primary Carburetor)

Hold throttle lever in wide open position, move choke valve toward closed position as far as possible with lever against unloader tang on throttle shaft, measure choke valve opening by inserting drill rod or gauge of correct size (see Specifications) between lower edge of choke valve and air horn wall. If choke opening not correct, adjust by bending choke rod at offset bend.

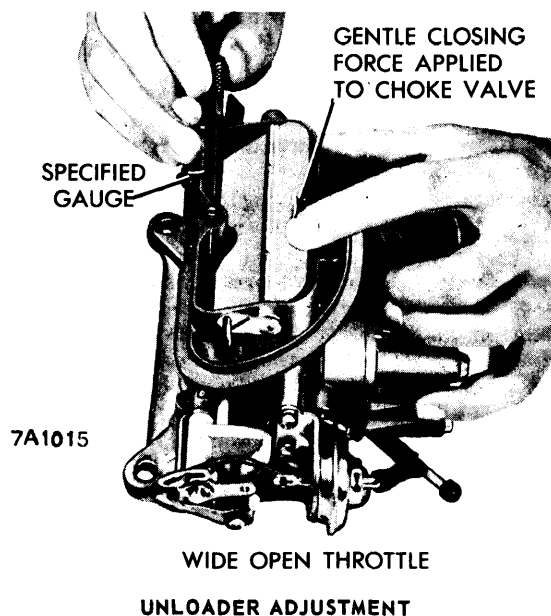

WIDE OPEN THROTTLE

UNLOADER ADJUSTMENT

Automatic Choke (Primary Carburetor)

Disconnect choke rod at intermediate lever, hold choke valve closed and pull choke rod up against its stop. Top of choke rod end should be even with bottom of hole in lever. Adjust by bending rod at offset bend, connect rod to lever. **CAUTION** - Rod end must enter hole freely and squarely.

Holley Carburetors

1968-69 CORVETTE HOLLEY TRIPLE CARBURETORS (Continued)

CARBURETOR ADJUSTMENT SPECIFICATIONS								
Holley Carb No.	Idle Speed (Engine RPM)		Initial Idle Mixture	Float Setting	Fast Idle (Off Eng.) Setting	Unloader Setting	Vacuum Break Setting	Auto. Choke Setting
	Hot	Fast ②						
R3659-A	①	2200	—	.350"	None	None	None	None
R4055-A	③ ①	2200	1 Turn	.350"	.025"	.275"	.250"	⑤
R4056-A	④ ①	2200	1 Turn	.350"	.025"	.275"	.250"	⑤
R3659-A ⑨	⑤	2200	—	.350"	None	None	None	None
R4055-1A	③ ⑤	2200	1 Turn	.350"	.025"	.250"	.275"	⑤
R4056-1A	③ ⑤	2200	1 Turn	.350"	.025"	.250"	.250"	⑤

- ① - Auto. Trans. in DRIVE.
 ② - With fast idle lever on HIGH step of fast idle cam.
 ③ - 750 RPM (Synchro-mesh Cars). Air Cond. OFF.
 ④ - 600 RPM (Auto. Trans. Cars). Air Cond. OFF.
 ⑤ - Interference fit of rod. See text for adjustment.
 ⑥ - Auto. Trans. in DRIVE, Air Cond. OFF except where noted.

- ⑦ - 400 HP - (Synchro-mesh) 800 RPM with Air Cond. ON.
 435 HP - (Synchro-mesh) 750 RPM with Air Cond. OFF.
 ⑧ - 400 HP - (Auto. Trans.) 600 RPM with Air Cond. ON.
 435 HP - (Auto. Trans.) 750 RPM with Air Cond. ON.
 400 RPM (Solenoid not energized) with Air Cond. OFF.
 ⑨ - 1969 Model carburetor.

Closing Rod (Secondary Carburetor)

With engine fully warmed, choke valve fully opened, and closing rod ends disconnected from each secondary carburetor, set idle to specifications and turn off engine. With clevis pin bottomed in primary carburetor throttle slot, adjust rear closing rod so it is 1/2 of a rod diameter short of rear secondary throttle lever hole, and install. Adjust front closing rod to just enter front secondary throttle lever hole, and install. Clevis pin should now be just above bottom of primary throttle slot.

Fast Idle Cam (Off Engine) (Primary Carburetor)

With carburetor off engine, open throttle valves slightly, close choke valve to position fast idle lever tang against top step of fast idle cam, close throttle valves. Measure throttle valve opening by inserting drill rod or gauge of correct size (see specifications) between throttle valve edge and carburetor wall on idle transfer slot side. Adjust by bending fast idle lever as necessary.

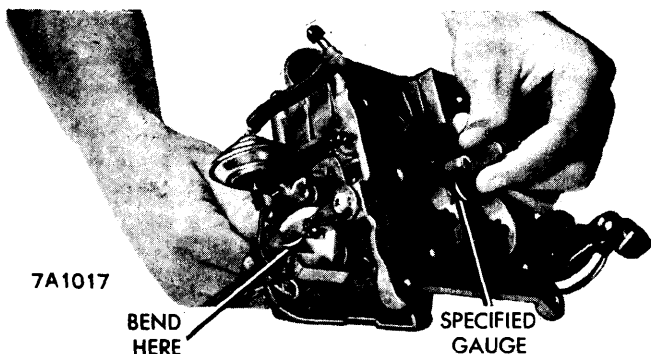

FAST IDLE CAM ADJUSTMENT

Dry Fuel Level (Off Engine) (All Carburetors)

Invert fuel bowl and float assembly so that float rests against seated intake needle, measure distance from top of float at ends and inner surface of fuel bowl (see Specifications). To adjust, loosen lock screw and turn adjusting nut on adjustable intake needle seat, snug lock screw. *NOTE - This is a preliminary adjustment. Check and adjust fuel level after carburetor installed on engine.*

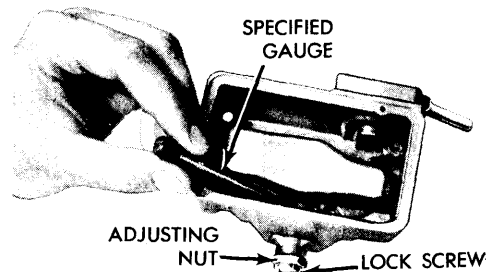

FLOAT LEVEL ADJUSTMENT (OFF ENGINE)

OVERHAUL

OVERHAUL NOTE: Model 2300 (secondary carburetors) do not have choke system, accelerating pump system, or power enrichment system. They have a different metering body assembly and special overhaul procedure is required.

Disassembly (Primary Carburetor 2300C)

Remove fuel bowl screws, remove fuel bowl assembly, metering body, splash shield and gasket. Disconnect vacuum hose from vacuum break diaphragm. Remove throttle body attaching screws and remove throttle body and gasket from main body. Disassemble parts as follows:

Fuel Bowl - Remove fuel inlet baffle, take out float hinge screws and remove float. Loosen inlet needle seat lock screw, turn adjusting nut counterclockwise to remove needle and seat assembly. Remove sight plug and gasket. Remove fuel inlet fitting, fuel filter, spring, and gasket. Take out pump cover screws, remove pump cover, diaphragm, and spring. Check pump inlet check ball for free movement, replace bowl if ball, retainer, or pump passage damaged.

1968-69 CORVETTE HOLLEY TRIPLE CARBURETORS (Continued)

Metering Body - Remove metering jets (use wide blade screwdriver) and power valve (use 1" 12-point socket). Remove vacuum fitting and idle mixture adjusting needles and seals.

Main Body - Take out vacuum break diaphragm mounting screws, disconnect link at choke lever and remove vacuum break unit. Remove choke lever and fast idle cam. Take out pump discharge nozzle retaining screw, remove nozzle and gasket, then invert main body to drop out pump discharge check valve. Further disassembly is not required for routine cleaning (choke rod seal will withstand normal cleaning procedure).

Throttle Body - If necessary to remove throttle valves or shaft for replacement, file off staked ends of attaching screws, remove screws and throttle valves, slide throttle shaft out. Remove accelerating pump cam from throttle lever.

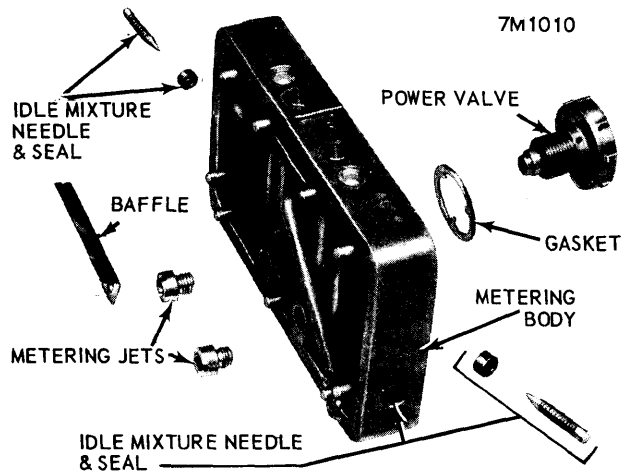

METERING BODY (PRIMARY CARBURETOR)

Fuel Bowl - Remove fuel inlet baffle, take out float hinge screws and remove float. Loosen inlet needle seat lock-screw, turn adjusting nut counterclockwise to remove needle and seat assembly. Remove sight plug and gasket. Remove fuel inlet fitting, fuel filter, spring, and gasket.

Metering Body - Take out six retaining screws and remove metering body from side of main body. Remove plate and gasket from metering body dowels.

Main Body - Main body cannot be disassembled.

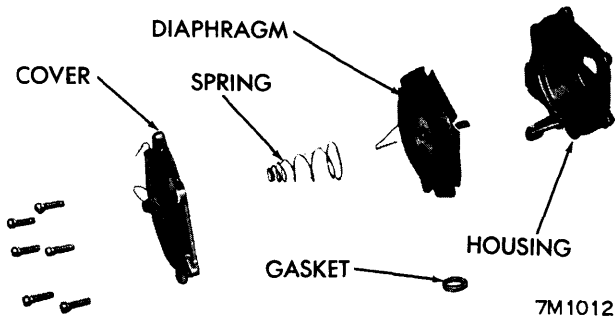

SECONDARY CARBURETOR THROTTLE DIAPHRAGM ASSEMBLY

Disassembly (Secondary Carburetor 2300)

Remove fuel bowl screws, remove fuel bowl, and gasket. Disconnect secondary diaphragm housing assembly link from throttle lever, take out mounting screws and remove diaphragm housing assembly from carburetor body. Remove throttle body attaching screws and remove throttle body and gasket from main body. Disassemble parts as follows.

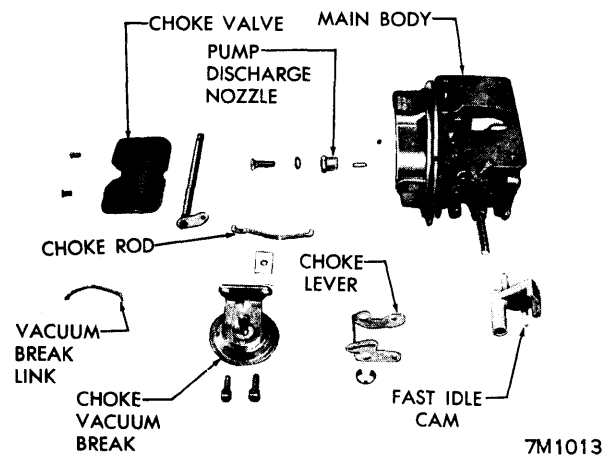

MAIN BODY ASSEMBLY (PRIMARY CARBURETOR)

Throttle Body - See Primary Carburetor (above) for replacement of throttle valves and shafts.

Secondary Diaphragm Housing Assembly - Check for leaks by pressing in on rod and holding finger over vacuum hole, then release rod. Rod should remain in. If rod moves out, disassemble housing by taking out cover screws, lift off cover, remove diaphragm and spring.

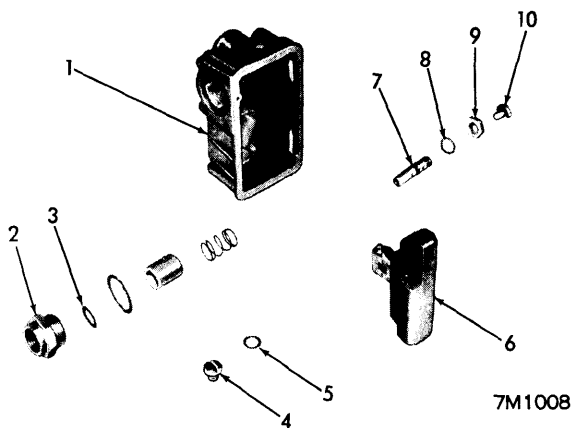

- | | |
|----------------------|-----------------------------|
| 1. Float Bowl | 6. Float |
| 2. Inlet Nut | 7. Needle and Seat Assembly |
| 3. Inlet Nut Gasket | 8. Gasket |
| 4. Sight Plug | 9. Adjusting Nut |
| 5. Sight Plug Gasket | 10. Lockscrew |

FUEL BOWL ASSEMBLY (PRIMARY CARBURETOR)

Cleaning & Inspection (All Carburetors)

Clean throttle body (if not disassembled), vacuum break, and all non-metallic parts in alcohol or gasoline, clean castings and all other parts in cleaning solvent, dry parts and blow out all passages with compressed air. Inspect all parts for wear or damage.

Holley Carburetors

1968-69 CORVETTE HOLLEY TRIPLE CARBURETORS (Continued)

Reassembly (All Carburetors)

Use all new gaskets. Assemble carburetor by reversing disassembly procedure and note the following:

Throttle Valve Installation - Install throttle shaft in throttle body, install valves on shaft with identification numbers down toward manifold but do not tighten screws, then center throttle valves by holding them closed while tightening the screws, stake screws while supporting shaft.

Idle Mixture & Idle Speed Screws - Use new seal on idle mixture screws when installing screws in metering body, set both screws one turn open from lightly seated position for preliminary setting. Install idle speed adjusting screw and spring on primary carburetor, turn screw in until it just contacts throttle lever with throttle valves closed, then turn screw in additional 1/2 turns for preliminary setting.

Choke Valve Installation - Install choke rod and seal in main body, then install choke shaft and connect upper end of choke rod to choke lever. Install choke valve on choke shaft (do not tighten screws), then hold valve closed to center it in air horn while tightening retaining screws, stake screws by squeezing with pliers. Check for binding. Choke valve should fall open of own weight.

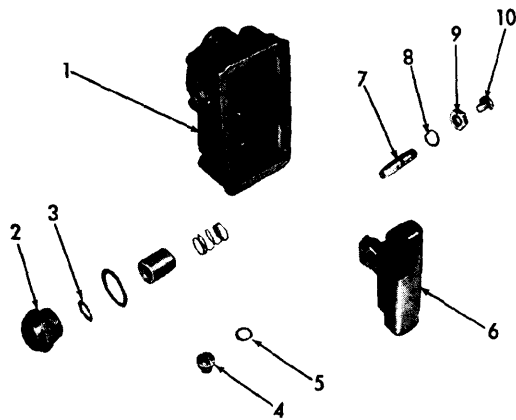

- | | | |
|---------------------|-----------------------------|------------------|
| 1. Float Bowl | 5. Sight Plug Gasket | 8. Gasket |
| 2. Inlet Nut | 6. Float | 9. Adjusting Nut |
| 3. Inlet Nut Gasket | 7. Needle and Seat Assembly | 10. Lockscrew |
| 4. Sight Plug | | |

FUEL BOWL ASSEMBLY (SECONDARY CARBURETOR)

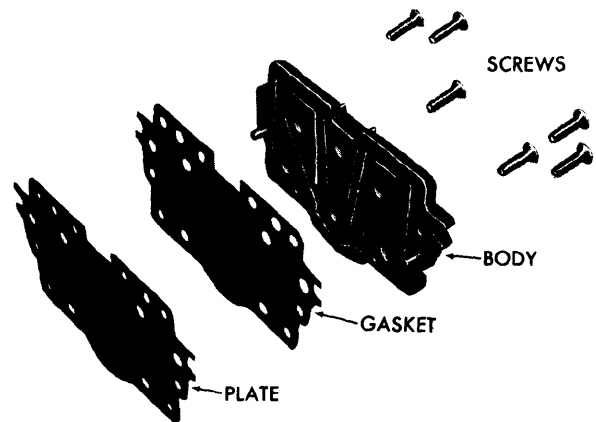

METERING BODY (SECONDARY CARBURETOR)

7M1011