

1968-69 FORD (AUTOLITE) 4-BARREL MODEL 4300

1968 U.S. Thermactor & IMCO Engines

COMET, COUGAR, FALCON, MONTEGO, & MUSTANG	Ford Carburetor No.	
	Synchro-mesh	Auto. Trans.
302" V8	C8ZF-C	C8ZF-D

FORD		
390" & 428" V8	C8AF-A, AR.....	C8AF-B, C

MERCURY		
390" & 428" V8	C8AF-A, AR.....	C8AF-B, C

THUNDERBIRD		
390" V8		C8AF-B
429" V8 (No Air Cond.)		C8SF-A, E
(With Air Cond.)		C8SF-B

LINCOLN CONTINENTAL		
460" V8		C8VF-A, F, H

LINCOLN CONTINENTAL MARK III		
460" V8		C8SF-G

1968 Export Non-Emission Engines

COMET, COUGAR, FALCON, MONTEGO & MUSTANG	Ford Carburetor No.	
	Synchro-mesh	Auto. Trans.
302" V8	C8ZF-A	C8ZF-B

1969

FAIRLANE & MONTEGO	Ford Carburetor No.	
	Synchro-mesh	Auto. Trans.
351" V8	C9ZF-C	C9OF-D
390" V8 (GT)	C9ZF-E	C9OF-E
COUGAR & MUSTANG		
351" V8	C9ZF-C	C9ZF-D
390" V8 (GT)	C9ZF-E	C9ZF-F
FORD & METEOR		
429" V8	C9AF-G	② C9AF-R
MERCURY		
429" V8		C9AF-R
THUNDERBIRD		
429" V8		C9SF-G, H
LINCOLN CONTINENTAL		
460" V8	② C8VF-J, C9LF-A	
CONTINENTAL MARK III		
460" V8		② C9LF-J

① - Carburetor number prefix and suffix with basic part number (9510) omitted.

② - Carburetor Nos. C9SF-G, H may also be used.

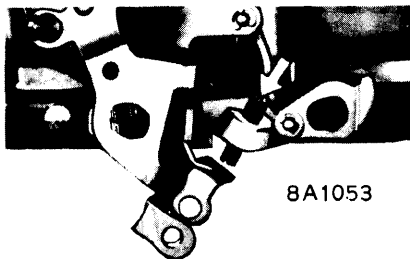

**IDLE SPEED ADJUSTMENT
(EXCEPT THUNDERBIRD)**

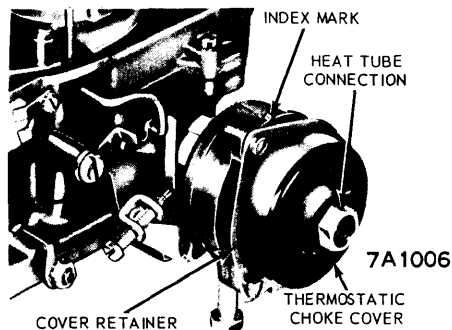

AUTOMATIC CHOKE ADJUSTMENT

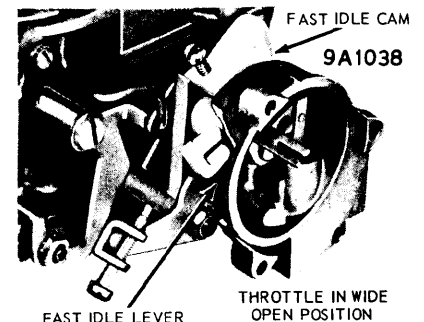

UNLOADER CLEARANCE ADJUSTMENT

► CHANGES, CAUTIONS, CORRECTIONS

► **1967-68 FORD MOTOR CO. MODEL 4300 CARBURETORS AIR CLEANER ASSEMBLY INSTALLATION CAUTION:** To prevent damage to secondary air valve link, always remove air cleaner cover and take care not to bend air valve link (watch through air cleaner).

► **1968 MERCURY MODELS WITH 390" & 428" V8 HAVING ENGINE STALL ON TRANSMISSION ENGAGEMENT AND AUDIBLE VACUUM LEAK CORRECTION:** Problem may be caused by incorrect carburetor spacer to manifold gasket usage. If an .010" feeler gauge will slip under P.C.V. vacuum take-off tube, remove carburetor and install these gaskets: C8SZ-9447-A is installed between carburetor and spacer with label "front" to front of engine. C8SZ-9447-B is installed between manifold and spacer, with tab projection between rear bolt holes.

► **THERMACTOR & IMCO ENGINES NOTE:** These engines have specially calibrated carburetors and distributors with related control units, and closed-positive crankcase ventilation system. **Thermactor Engines** - Have air pump for air injection in engine at exhaust valve ports.

CARBURETOR IDENTIFICATION

Carburetor number prefix and suffix (example C8AF-A) is stamped on tag attached to carburetor by one air horn screw. First letter on second line of tag ("A" etc.) indicates design changes which may affect parts replacement.

DESCRIPTION

Four barrel downdraft carburetors of same design used on previous models except for design changes as follows:

Fuel Bowl Vent Valve - External bowl vent with adjustable vent valve used only on Lincoln Continental & Mark III, and Thunderbird carburetors. All other carburetors have internal bowl vents without a valve.

Secondary Air Valve Torsion Spring - Not used (replaced by spring located in secondary valve dashpot cylinder). No adjustment required.

Idle Speed Adjusting Screw - All carburetors have throttle lever stopscrew for idle speed adjustment.

Idle Limiter Caps - These caps installed on idle mixture adjusting screw to limit range of adjustment for exhaust emission control. *Do not remove or deform caps and make certain ear on cap contacts stop on carburetor body to provide positive stops for mixture screw adjustment range.*

Ford Carburetors

1968-69 FORD (AUTOLITE) 4-BARREL MODEL 4300 (Continued)

ADJUSTMENT

ADJUSTMENT NOTE - Before making idle speed and mixture adjustment, turn both idle mixture screws counter-clockwise to limit of travel with limiter cap ear against stop on carburetor body. On all carburetors except 1968 Thunderbird, turn throttle stopscrew in 1½ turns beyond point where screw contacts throttle lever (for initial idle speed setting). On 1968 Thunderbird carburetors, turn idle air bypass screw out 3½ turns from lightly seated position for initial idle speed setting. Stabilize engine and underhood temperature by running engine at 1500 RPM for 20 minutes, then make adjustment as follows:

Idle Speed & Mixture

With engine at normal operating temperature (choke valve wide open and fast idle inoperative), disconnect parking brake release vacuum line at power cylinder and block this line (where used), place automatic transmission selector lever in Drive, turn headlights ON (to place alternator under load), turn air conditioner ON (if used). With air cleaner installed (**NOTE** - if necessary to remove air cleaner for adjustment, final idle speed and mixture setting must be checked with air cleaner in place), make certain hot idle compensator closed, adjust throttle stopscrew (idle air bypass screw on 1968 Thunderbird) for correct engine idle speed (see specifications), turn both idle mixture adjusting screws inward (clockwise) for smoothest possible idle within range of adjusting screw limiters. Recheck idle speed and repeat idle mixture adjustment if necessary.

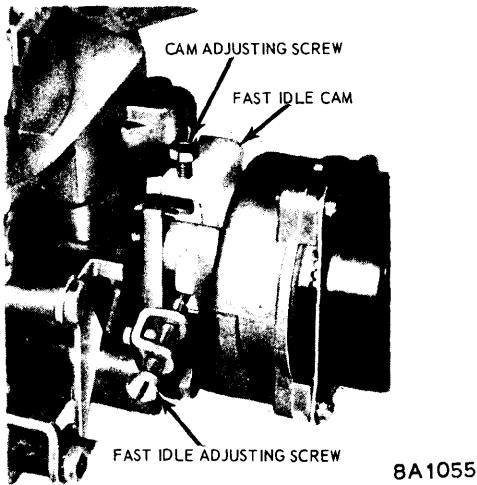

FAST IDLE SPEED ADJUSTMENT

Fast Idle Speed

Rotate fast idle cam so that fast idle speed screw contacts kick-down (center) step of cam, adjust fast idle screw for specified fast idle engine speed (see Specifications).

Throttle Linkage Adjustment (Auto. Trans. Cars)

See **CARBURETOR** on car model *Tune-Up* pages.

Accelerating Pump

Pump link (operating arm) and bracket have three holes for pivot pin engagement and pump stroke is adjusted by moving pin as required. **NOTE** - Vent valve adjusting lever is mounted on pump link at pivot pin. Vent valve must be checked and adjusted whenever pump link setting changed (used on some carburetors only).

Pump Stem Height - With throttle valves closed, use scale to measure pump stem height or distance from bowl cover to top of pump plunger stem. If this distance not correct (see specifications below), adjust by bending pump connector rod as required. Check Vent valve setting after making this adjustment.

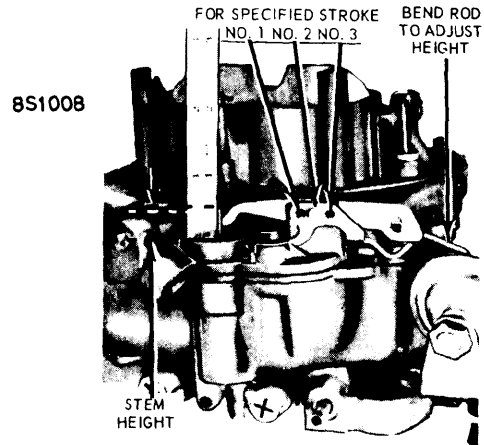

ACCELERATING PUMP HEIGHT

Pump Stem Height

Engine	Pump Stem Measurement
1968 302", 390", 428" V8	.4375"
1968 429", 460" V8	.3125"
1969 351", 390" V8	.480" ± .015"
1969 429", 460" V8	.425" ± .015"

Recommended Setting - See Specifications for pump setting on each model and illustration for numbering of pivot pin engagement holes. **CAUTION** - Pump lever supports should be set for .010" total clearance between pump lever and supports.

Pump Adjustment - Disconnect pump rod from pump link before removing pump pivot pin. Line up holes in vent lever, pump link, and pivot hole in main body casting before attempting to reinstall pivot pin, make certain pivot pin retainer is properly installed on pin.

Fuel Bowl Vent Valve

NOTE - Adjustable vent valve used only on 1968 carburetors and on 1969 Lincoln Continental, Mark III and Thunderbird carburetors. Vent valve must be checked and adjusted whenever accelerating pump setting is changed. With throttle valves in closed position, check clearance between vent valve and valve seat with a feeler gauge (see specifications). If valve opening not correct, adjust by bending vent valve lever end (which contacts pump arm) up or down as necessary.

1968-69 FORD (AUTOLITE) 4-BARREL MODEL 4300 (Continued)

CARBURETOR ADJUSTMENT SPECIFICATIONS									
Ford Carb. Number	Idle Speed (Engine RPM)		Float Level		Fuel Bowl Vent Valve ^④	Choke Valve Pull-down	Fast Idle Cam Clearance	Accel. Pump Setting	Automatic Choke Setting
	Hot ^①	Fast ^②	Primary Valve	Auxiliary Valve ^③					
C8AF-A	625	1300	25/32"	1/16"	.070"	.120"	.100"	#3	1 Rich
C8AF-B	550	1400	25/32"	1/16"	.070"	.140"	.100"	#3	2 Rich
C8AF-C	550	1400	-	-	-	-	-	-	-
C8AF-AE	600	1350	25/32"	1/16"	.070"	.140"	.120"	-	2 Rich
C8AF-AR	625	1300	3/4"	1/16"	.070"	.120"	.100"	#3	1 Rich
C8AF-AS	550	1400	25/32"	1/16"	.070"	.160"	.100"	-	Index
C8SF-A, B, E	550	1500	25/32"	1/16"	.070"	.230"	.160"	#2	1 Rich
C8SF-G	550	1500	25/32"	1/16"	.070"	.230"	.160"	#2	1 Rich
C8VF-A, F, H	550	⑤	25/32"	1/16"	.070"	.230"	.160"	⑥	1 Rich
C8ZF-C	625	1250	13/16"	1/16"	.070"	.120"	.090"	#2	Index
C8ZF-D	550	1400	13/16"	1/16"	.070"	.140"	.100"	#1	Index
C8SF-G ^③	550	1300 ^⑦	25/32"	1/16"	.070"	.230" ^④	.160" ^④	#2	1 Rich
C8SF-H	550	1300 ^⑦	25/32"	1/16"	.070"	.230" ^④	.160" ^④	#2	1 Rich
C8VF-J	550	1300 ^⑦	25/32"	1/16"	.070"	.230" ^④	.160" ^④	#2	1 Rich
C9AF-G	650	1200 ^⑦	25/32"	1/16"	None	.270" ^④	.220" ^④	#2	Index
C9AF-R	575	1300 ^⑦	25/32"	1/16"	None	.230" ^④	.160" ^④	#2	1 Rich
C9LF-A, J	550	1300 ^⑦	25/32"	1/16"	.070"	.230" ^④	.160" ^④	#2	1 Rich
C90F-D	575	1400 ^⑦	13/16"	1/16"	None	.160" ^④	.100" ^④	#2	1 Lean
C90F-E	550	1400 ^⑦	13/16"	1/16"	None	.250" ^④	.230" ^④	#3	1 Lean
C9ZF-C	675	1250 ^⑦	13/16"	1/16"	None	.170" ^④	.130" ^④	#2	2 Lean
C9ZF-D	575	1400 ^⑦	13/16"	1/16"	None	.160" ^④	.100" ^④	#2	1 Lean
C9ZF-E	700	1300 ^⑦	13/16"	1/16"	None	.230" ^④	.210" ^④	#3	Index
C9ZF-F	550	1400 ^⑦	13/16"	1/16"	None	.250" ^④	.230" ^④	#3	1 Lean

- ① - Auto. Trans. in DRIVE, headlights ON.
 ② - Fast idle screw on center step of fast idle cam.
 ③ - Plus or minus 1/64".
 ④ - Plus or minus .010".

- ⑤ - 1500 (C8VF-F), 1300 (C8VF-H).
 ⑥ - #1 (C8VF-F), #2 (C8VF-H).
 ⑦ - Plus or minus 1/32".
 ③ - 1969 Carburetor with same number as a 1968 model.

Choke Valve Pull-down & Fast Idle Cam Linkage

Make these adjustments in order as follows:

Choke Valve Pull-down - Disconnect heat tube at thermostatic choke cover, remove cover and coil assembly. Bend a .036" wire gauge at a 90° angle approximately 1/8" from end, insert bent end of gauge between piston slot and upper edge of right hand slot in choke housing, rotate choke lever counterclockwise until gauge held snugly in piston slot and maintain light pressure on choke lever to hold gauge in place. Use gauge or drill of correct size (see Specifications) to check clearance between lower edge of choke valve and air horn wall. If this pull-down clearance not correct, adjust by bending adjusting arm on choke shaft lever up or down as necessary. Remove piston gauge.

Fast Idle Cam Linkage - Install choke cover and thermostatic coil loosely (make certain coil end engages choke lever slot), rotate cover to a 90° Rich position, position fast idle speed screw on kick-down (center) step of fast idle cam and hold it in this position. Use gauge or drill of correct size (see Specifications) to check clearance between lower edge of choke valve and air horn wall. If fast idle cam clearance not correct, adjust by turning fast idle cam adjusting screw in or out as necessary

(CAUTION - This is not the fast idle speed adjusting screw - see illustration). Adjust automatic choke to specified setting.

Unloader

Hold throttle valves in wide open position, rotate choke valve toward closed position until pawl on fast idle lever contacts fast idle cam. Use gauge or drill of correct size to check clearance between lower edge of choke valve and air horn wall. This clearance should be .300" (all carburetors). If clearance not correct, adjust by bending pawl on fast idle lever forward or backward as necessary.

Automatic Choke

NOTE - Heat tube connection on cover must be loosened to remove or adjust choke cover (hold heat connection on cover with wrench while loosening or tightening connector nut). Loosen choke cover and thermostatic coil retainer screws, rotate cover to align index mark on cover flange with correct graduation of scale on housing (see Specifications). Tighten retainer screws and heat tube connection.

1968-69 FORD (AUTOLITE) 4-BARREL MODEL 4300 (Continued)

7A1009

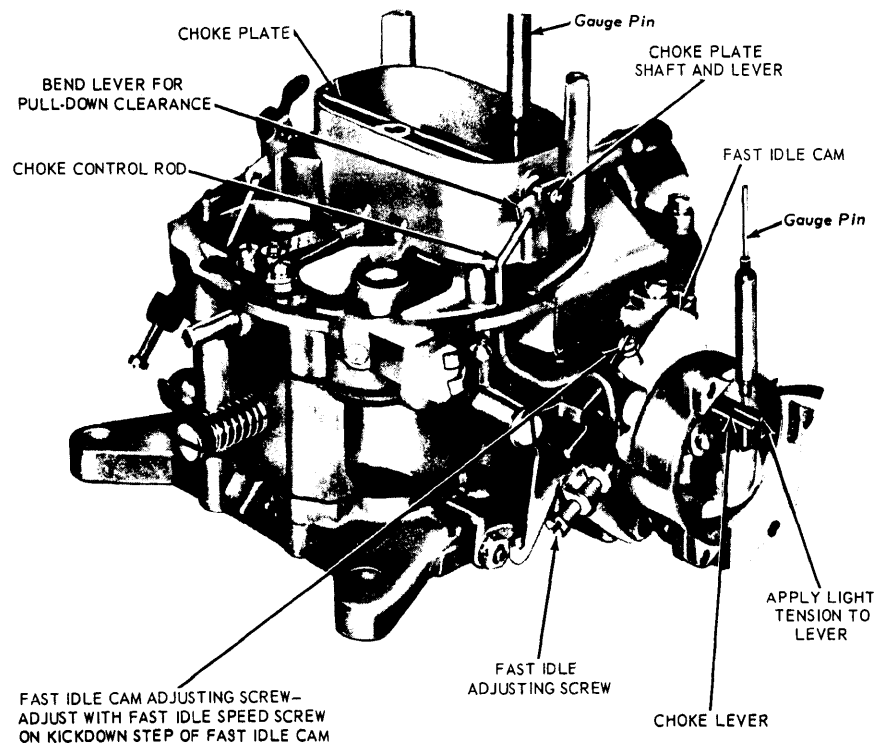

CHOKE VALVE PUL L-DOWN & FAST IDLE CAM ADJUSTMENT

Secondary Air Valve Spring

Spring is located in secondary air valve dashpot cylinder and no adjustment is required.

Float Level

CAUTION - Two fuel inlet valves used and float level must be adjusted exactly as detailed below. It is recommended that a Float Gauge and Float Bending tool be made up to dimensions shown in illustration for this purpose.

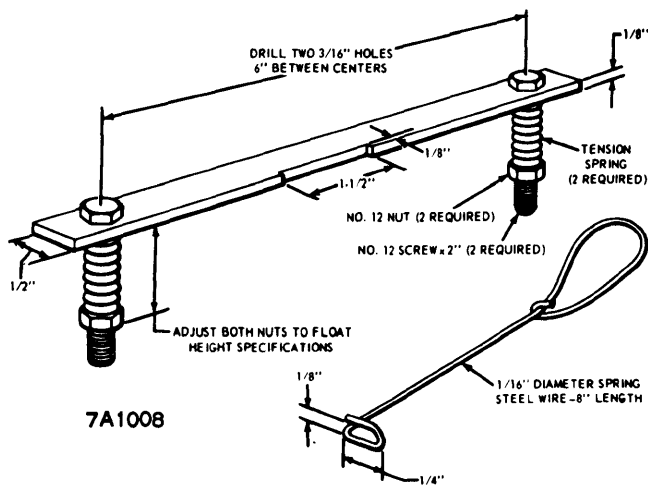

7A1008

FLOAT LEVEL GAUGE & BENDING TOOL

Float Level (Primary Fuel Valve) - Adjust nuts on float level checking gauge for correct float level setting (see Specifications). With air horn and float assembly removed and inverted, install float gauge over floats with locating bolts installed in outboard holes of air horn. Both floats should just touch underside of float gauge bar. Align floats by slightly twisting float arms, adjust float height by bending primary needle tab (inner tab on float arm) up or down as necessary. **CAUTION** - Raise floats so that tab clears primary needle when bending tab.

Auxiliary Fuel Valve - After adjusting primary fuel valve and with float gauge installed (above), check clearance between auxiliary fuel valve pin and tab on rear of float arm. If clearance not correct (see Specifications), adjust by bending this tab up or down as required.

Secondary Throttle Valve Opening

Secondary throttle lever is mechanically linked to primary throttle lever and secondary throttle valves begin to open when primary throttle valves 3/4 open (secondary lockout lever actuated by choke mechanism locks secondary throttle valves closed when engine is cold). Check secondary throttle linkage by opening primary throttle valves until clearance between lower edge of valves and carburetor wall is exactly 7/16" (all models). Use 7/16" gauge or drill rod to check this clearance. At this point, pawl on throttle lever should just contact secondary throttle over-travel spring.

Dashpot

With throttle valves closed at curb idle position, depress dashpot plunger fully and check clearance between dashpot plunger stem and throttle lever. If this clearance not correct (see specifications below), adjust by loosening locknut and turning dashpot in or out of mounting bracket as required.

1968-69 FORD (AUTOLITE) 4-BARREL MODEL 4300 (Continued)

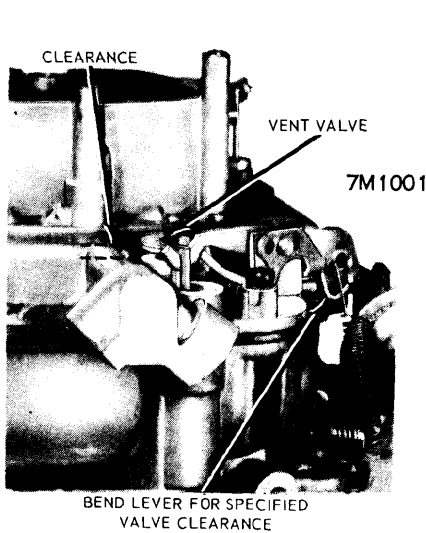

FUEL BOWL VENT VALVE ADJUSTMENT

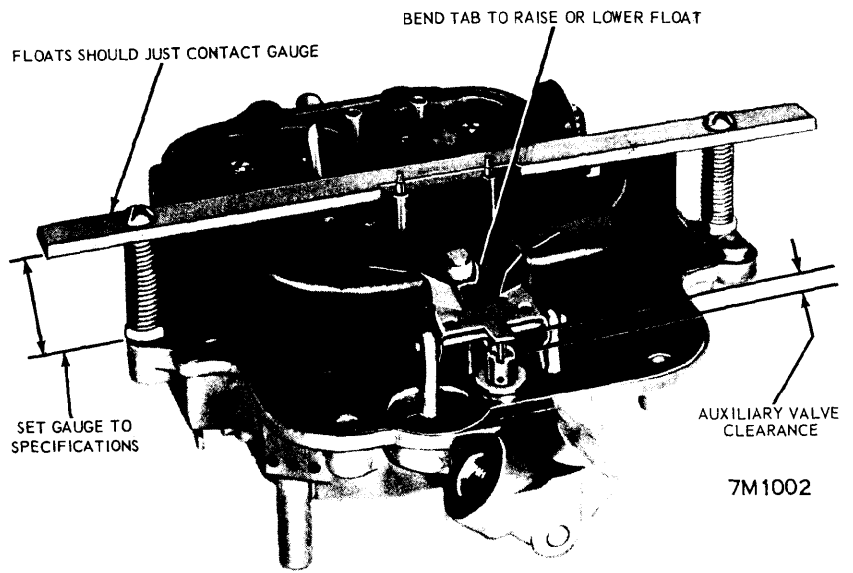

FLOAT LEVEL ADJUSTMENT

Dashpot Setting

Carburetor	Dashpot Stem Clearance
C8AF-A, AR, AS, B, C	3/32" (.093")
C8AF-AE	
C8OF-AA, AB, C, D	.100"
C8SF-A, F	3/32" (.093")
C8VF-A, F	3/32" (.093")
C8ZF-C	1/16" (.060")
C8ZF-D	3/32" (.093")
C8SF-G, H, C8VF-J	3/32" (.093")
C9AF-G, C9LF-A, J; C9ZF-C	3/32" (.093")
C9ZF-E	1/8" (.062")

OVERHAUL

IDLE LIMITER CAP REPLACEMENT NOTE - If idle limiter caps have been removed for carburetor overhaul or adjustment, see replacement procedure in "Ford Motor Co. IMCO & Thermactor Engines on Page 2-433.

NOTE - Carburetor consists of three main castings: Air Horn, Main Body, and Throttle Body, which are separated and then disassembled separately as follows:

Disassembly

Air Horn - 1) Disconnect choke control rod from automatic choke lever and accelerating pump rod from throttle lever. Remove all air horn-to-main body retaining screws (**NOTE** - One screw retains fuel bowl external vent valve), carefully lift air horn off main body.

2) Remove float pivot pin and lift out float assembly, use correct size screwdriver (or jet removal tool) to remove main and auxiliary fuel inlet seat assemblies and gaskets.

3) Disconnect secondary air valve lever rods from dampener piston assembly and air valve, remove dampener piston and rod assembly.

4) If necessary to remove secondary air valves or shaft, scribe index mark on air valve housing and body casting, remove valve retaining screws and valves, then slide shaft out of air horn.

5) If necessary to remove choke valve or shaft, remove staking marks on choke valve retaining screws or file off flared portion of screws, remove retaining screws and valve, then slide shaft out of air horn.

6) Take out attaching screws and remove hot idle compensator valve assembly. *Do not remove power valve vacuum valve assembly unless it is to be replaced.* Remove staked areas and remove valve assembly carefully to avoid damage to air horn casting.

Main Body - 1) Invert main body assembly and catch accelerating pump discharge needle which will fall out.

2) Use 3/8" deep socket to remove power valve and jet tool to remove main metering jets from within fuel bowl.

3) Remove check ball retainer from bottom of accelerating pump cylinder with long nosed pliers, then invert main body and catch pump inlet ball check which will drop out.

4) Remove throttle body-to-main retaining screws from bottom of throttle body and separate the two castings.

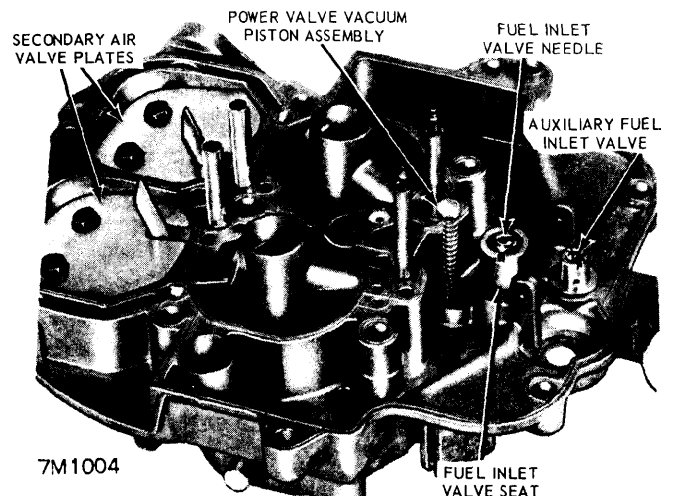

AIR HORN ASSEMBLY

Ford Carburetors

1968-69 FORD (AUTOLITE) 4-BARREL MODEL 4300 (Continued)

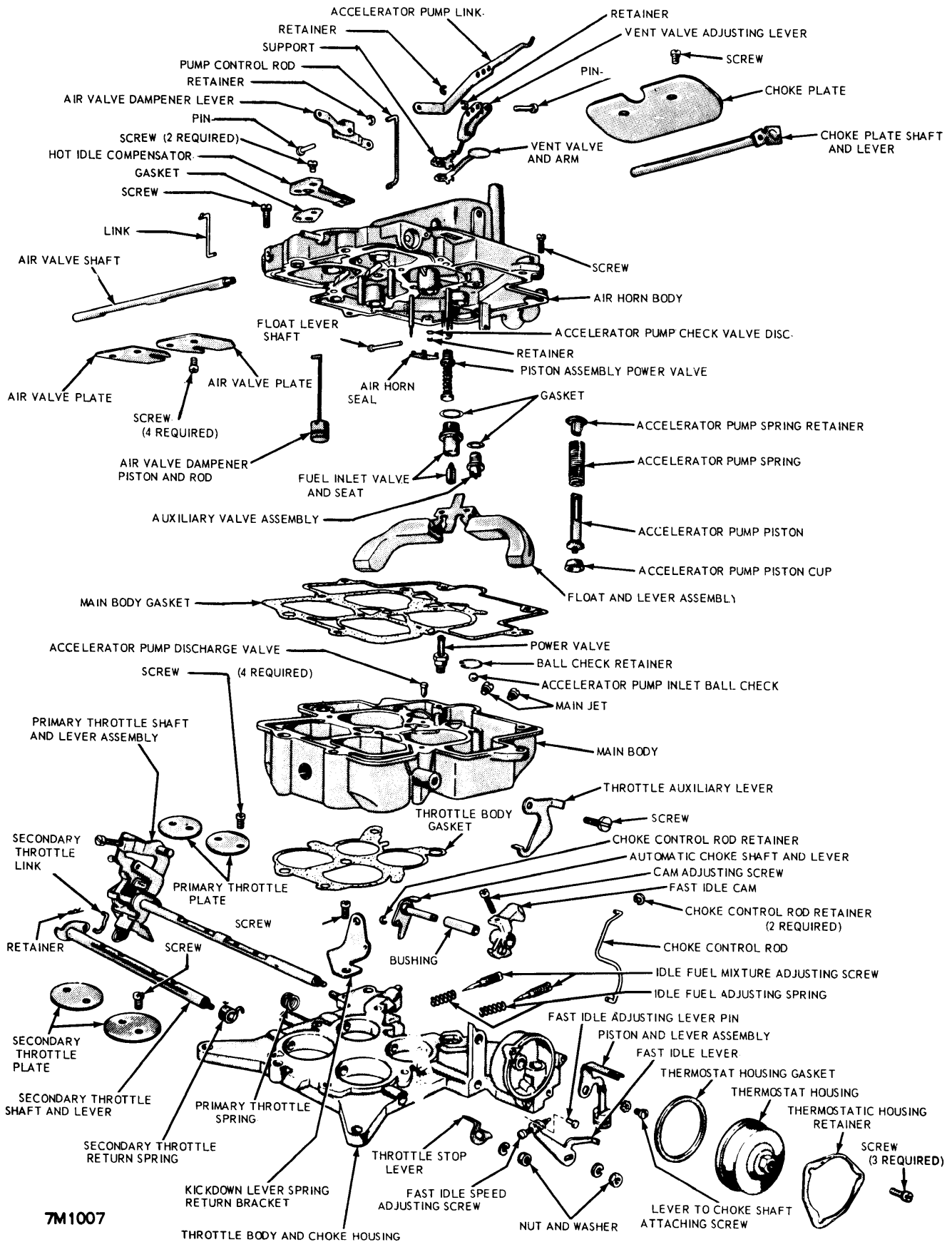

7M1007

FORD (AUTOLITE) 4-BARREL MODEL 4300 CARBURETOR ASSEMBLY

1968-69 FORD (AUTOLITE) 4-BARREL MODEL 4300 (Continued)

7S1026

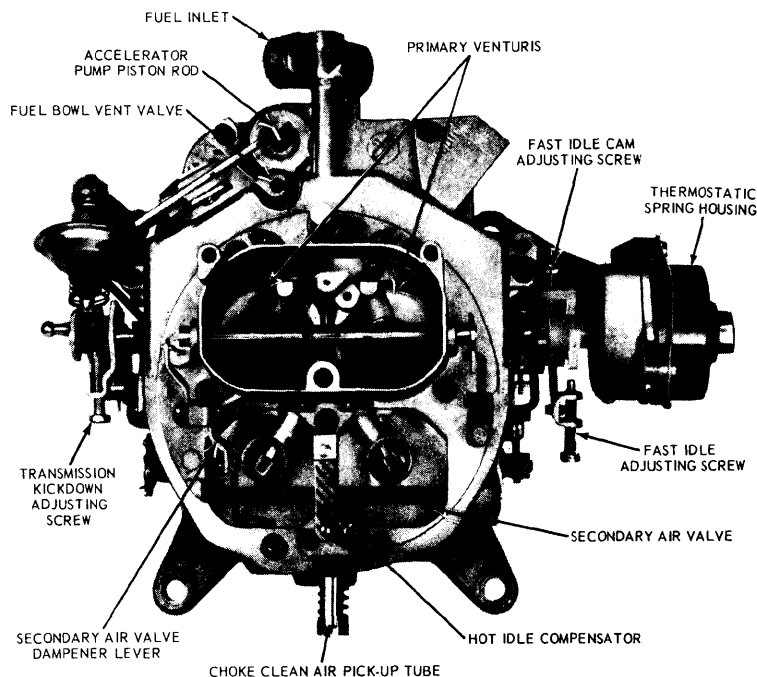

FORD MODEL 4300 CARBURETOR ASSEMBLY (TOP VIEW)

Throttle Body - 1) CAUTION - Do not remove idle mixture limiter caps, screws, and springs. Remove automatic choke housing cover screws, remove retainer, cover, gasket, and thermostatic spring assembly. Remove choke piston lever retaining screw, then remove piston assembly.

2) Remove secondary throttle-to-primary throttle lever connecting link. If necessary to remove primary or secondary throttle valves or shafts, remove staking marks on throttle valve attaching screws, remove screws and valves.

3) After valves removed, remove nut from secondary throttle shaft, slide shaft and return spring out of throttle body.

4) After valves removed, remove nut from primary throttle shaft and remove fast idle lever and adjusting screw, then slide primary throttle shaft and lever assembly out of throttle body. Remove throttle lever assembly retainer, slide lever and springs off shaft.

5) If necessary to remove fast idle cam or bushings, press bushing out of choke housing and bushing column. CAUTION - Housing and column must be properly supported during bushing removal and installation to prevent bending or breaking of the column.

Cleaning & Inspection

Clean all castings and metal parts in cleaning solution (plastic fast idle cam and air valve spring cover can be cleaned in the solution but floats and gaskets should not be immersed in the solution). Rinse parts in hot water, soak in gasoline, and dry with air. Blow out all passages, jets, and tubes with air. Inspect all parts for wear, distortion or damage. Make certain power valve piston and rod move freely. **CAUTION - Do not remove calibrating shims from power valve piston rod for cleaning and use care not to distort rod.**

Reassembly

Use all new gaskets. Reassemble carburetor by reversing disassembly procedure with particular attention to the following points:

Primary Throttle Valve Installation - Install return spring (coiled clockwise) on primary throttle shaft and insert shaft in throttle body. Position throttle valves on shaft with ground flat edge of valves facing upwards and toward idle mixture needles, install valve screws just snug. Rotate shaft to closed position, tap valves lightly to properly seat them in throttle bore (when viewed against a light, little or no light should be visible around valves), then tighten valve screws securely.

Fast Idle Cam & Bushing Installation - Start bushing through choke housing, position fast idle cam between

Ford Carburetors

1968-69 FORD (AUTOLITE) 4-BARREL MODEL 4300 (Continued)

housing and bushing column and slide bushing through fast idle cam, then support bushing column and press bushing into position in column. Clean bushing with 1/4" reamer before installing choke shaft and lever.

Choke Valve Installation - Insert choke shaft in air horn with lever end on automatic choke side, install choke valve and tighten attaching screws just snug, then close valve and tap lightly to position it in air horn, tighten attaching screws and stake screws to prevent loosening. Install a new seal on choke control rod, press seal into air horn and attach control rod to choke shaft lever (**CAUTION** - Seal must grip ledge in air horn at all four points to prevent unfiltered air entering carburetor).

Air Valve Installation - Slide air valve shaft in air horn with slotted end of shaft in air valve spring chamber. Position plain air valve in air horn opening adjacent to spring chamber and tighten attaching screws just snug, install air valve in other air horn opening with control rod eye facing upward, install attaching screws just snug. Close air valves and tap valves lightly to position them in air horn, then tighten attaching screws and stake the screws to prevent loosening.

NOTE - On 1968 carburetors, spring must be installed with outer hook at bottom of spring cavity when air valves are open (vertical) and hook opening must face toward left. Install housing retainer but do not tighten attaching screw until air valve spring tension adjusted (see specifications).

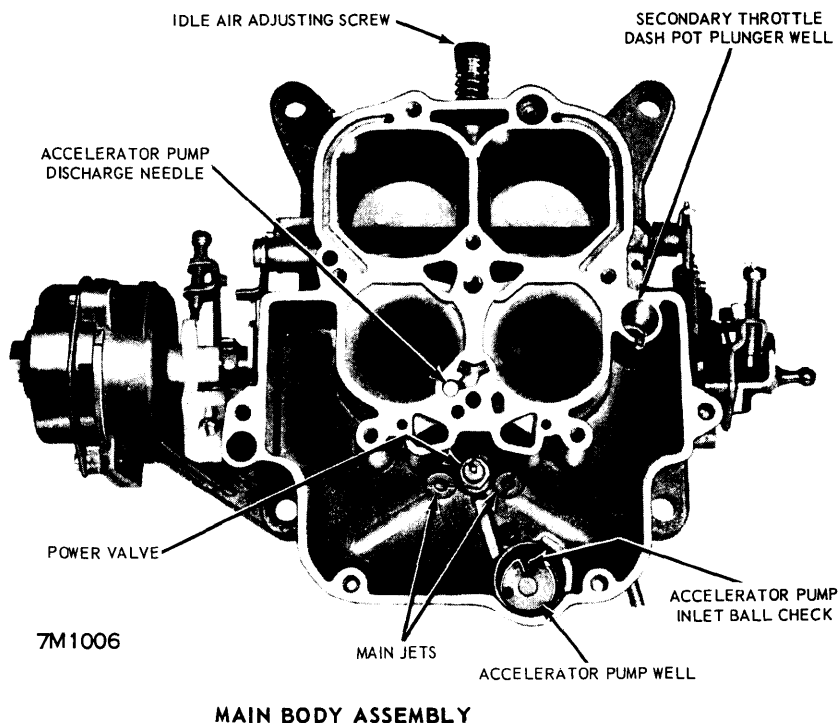

MAIN BODY ASSEMBLY

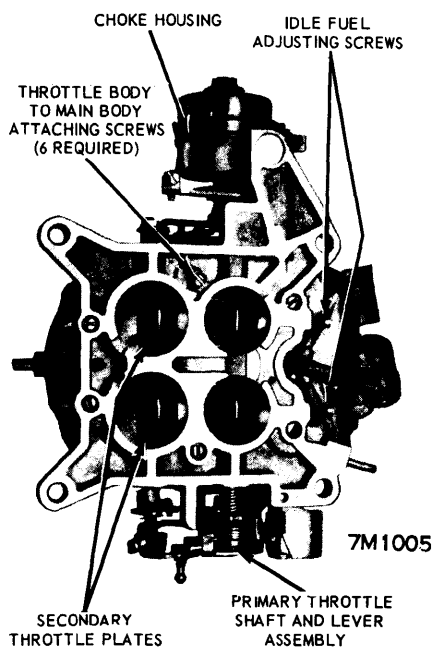

THROTTLE BODY ASSEMBLY