

## STROMBERG WWC 2-BARREL

<b>1960 DODGE V8</b>	<b>Stromberg Code No.</b>
361" Engine .....	3-188
<b>1961 CHRYSLER, DE SOTO, DODGE V8</b>	
361" Engine .....	3-188, 3-188A
<b>1962 CHRYSLER &amp; DODGE V8</b>	
361" Engine .....	3-201
<b>1963 CHRYSLER &amp; DODGE V8</b>	
361" Engine .....	3-221, 3-221A
<b>1964 CHRYSLER &amp; DODGE V8</b>	
361" Engine (Synchro-mesh) .....	3-244
361" Engine (Auto. Trans.) .....	3-242
<b>1965 CHRYSLER, DODGE &amp; PLYMOUTH V8</b>	
361" & 383" Engines (Synchro-mesh) .....	3-254
361" & 383" Engines (Auto. Trans.) .....	3-255
<b>1966 CHRYSLER, DODGE, PLYMOUTH</b>	
383" V8 (Std. - No "CAP")	
(Auto. Trans.) ① .....	3-262
383" V8 (With "CAP")	
(Auto. Trans.) ① .....	3-263
<b>1967 CHRYSLER, DODGE, PLYMOUTH</b>	
383" V8 (Std. - No "CAP")	
(Auto. Trans.) ① .....	3-276

① - Carter Model BBD Carburetor also used.

### ► CHANGES, CAUTIONS, CORRECTIONS

- **"CAP" CARBURETOR NOTE:** These "CAP" carburetors are special units used on cars with "Cleaner Air Package" and require special adjustment procedures for Idle Speed & Mixture Adjustment and Fast Idle Speed adjustment.
- **HARD COLD STARTING CORRECTION (Carburetors with Choke Vacuum Piston in Air Horn):** May be caused by piston sticking due to gum formations. Correct by removing air cleaner and squirting carburetor cleaner, alcohol, or lacquer thinner through piston link opening while operating choke by hand to remove gum formations and free piston.
- **1962 CHRYSLER & DODGE LEAN CONDITION CORRECTION:** Correct complaints of lean road load performance by installing .066" metering jets to replace original .065" jets. **CAUTION - Do not use Stromberg 38811-68 or 69 jets in these carburetors (use only in earlier carburetors).**
- **1963 361" ENGINE HARD STARTING & SLOW WARM-UP CORRECTION:** Remove choke unit and note position of index mark on indexing disc. If choke is indexed two notches lean, reindex to 1 notch rich.
- **1963 CHRYSLER & DODGE (361" ENG.) STALLING AFTER COLD START CORRECTION & CARBURETOR PRODUCTION CHANGE:** Stromberg WWC 3-221 has been replaced in production with WWC 3-221A to correct the above condition. To rework WWC 3-221, proceed as follows: Remove choke vacuum piston assembly from air horn and increase the size of bleed holes (4 holes) in piston, using a No. 54 drill. Adjust choke vacuum piston (see "Adjustments" below) so a 7/64" drill will fit between choke valve and air horn wall. Install a Welch plug and seal cylinder, then adjust hot idle and fast idle speeds to specifications.
- **1963 361" ENGINE HARD STARTING (DUE TO CHOKE NOT OPERATING PROPERLY):** This condition which may occur intermittently could be caused by choke thermostat coil catching on cast surface of choke

pocket. To check if coil is caught, a "twanging" noise will be heard when choke assembly is unbolted and removed from choke well. To correct, mark location of index mark on disc, then loosen choke coil adjusting locknut and rotate coil so free end of coil hangs down. Grind away the outer bend (see illustration), keeping contact face of coil as long as possible. Bend contact face of coil 10-15° toward choke rod, being careful not to distort coils of thermostat. Remove any sharp edges caused by grinding, then turn index disc until notch is opposite the 1 notch rich mark and tighten locknut.

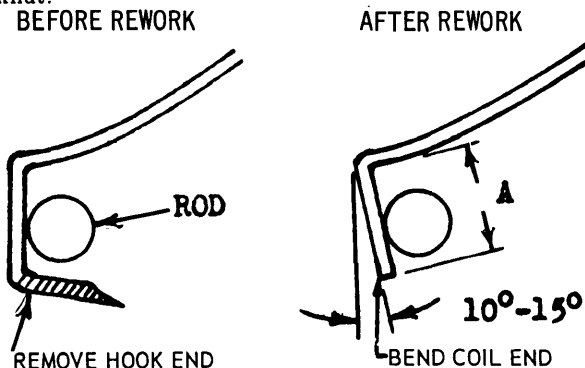

1963 CHOKE COIL REWORK 3F250

- **1965 361" & 383" ENGINE SURGE AT CONSTANT SPEED OR ON LIGHT ACCELERATION (Auto. Trans. with Code 3-255 Carburetors):** NOTE - Carburetors marked "A" or "B" following code number stamped on bowl cover have been corrected in production and do not require modification. This condition caused by lean mixture and can be corrected as follows: Remove carburetor and disassemble main body. Enlarge restrictions at bottom of two "Idle Down Channel Passages" (see illustration for location) using a 1.45 mm. (.057") drill. NOTE - No. 53 (.0595") drill may be used but any larger drill than .0595" will cause excessive richness and must not be used. Blow out all passages to remove drill chips, reassemble carburetor, make certain float level set to correct specifications as listed.

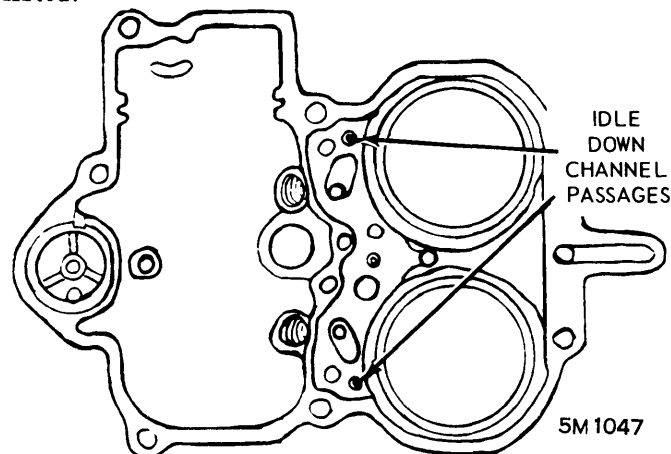

CODE 3-255 CARBURETOR SURGE CORRECTION

### CARBURETOR IDENTIFICATION

Stromberg code number is stamped on float bowl cover or on tag attached to carburetor by air horn screw. Prefix figure ("3") indicates vehicle make, following number indicates a particular carburetor model. Suffix

## STROMBERG WWC 2-BARREL (Continued)

letter (A, B, etc.) indicates changes in parts, jet calibration, or specifications as listed.

## DESCRIPTION

Two barrel downdraft type with main discharge nozzles and tubes, and idle tubes, mounted in separate venturi cluster which includes auxiliary venturis. All carburetors are used with separate "cross-over" or well type automatic choke. These carburetors have different design features requiring different adjustments as follows:

**Choke Vacuum Piston (1963 & Earlier Carburetors)** - Piston located in cylinder in air horn and linked directly to choke valve provides initial choke opening for starting. See "Choke Vacuum Piston" adjustment.

**Vacuum Kick Diaphragm (1964 & Later Carburetors)** - Vacuum diaphragm unit mounted on air horn and linked to choke shaft lever used instead of choke vacuum piston. See "Vacuum Kick (Choke Vacuum Diaphragm)" adjustment.

**Spring-Staged Choke (1965 & Later Carburetors)** - This reduces choke valve closing torque when engine cranked at low temperatures and results in better starting mixtures at both low and moderate temperatures. See "Spring-Staged Choke" adjustment.

## ADJUSTMENT

- **CARBURETOR RECONDITIONING NOTE:** After overhauling carburetor, it is important that following adjustments be made in the order indicated: Fast Idle Cam Position, Choke Vacuum Piston or Vacuum Kick Adjustment, Unloader, Accelerating Pump Travel, and Bowl Vent Valve.

## Idle Mixture &amp; Speed

**NOTE** - Adjust idle speed with **Headlights ON (Cars with Alternator)**, **Automatic transmission selector lever in "N"**, and **Air Conditioner ON**. Proceed as follows:

**Std. Carburetors** - With engine at normal operating temperature, turn air conditioning ON (if used), adjust idle speed to correct engine RPM (see Specifications)

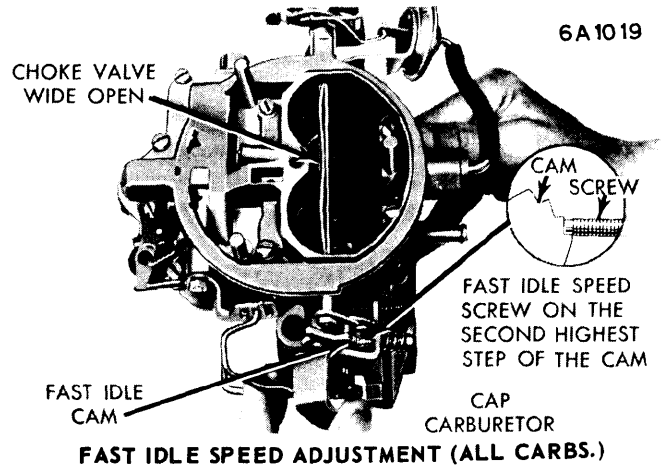
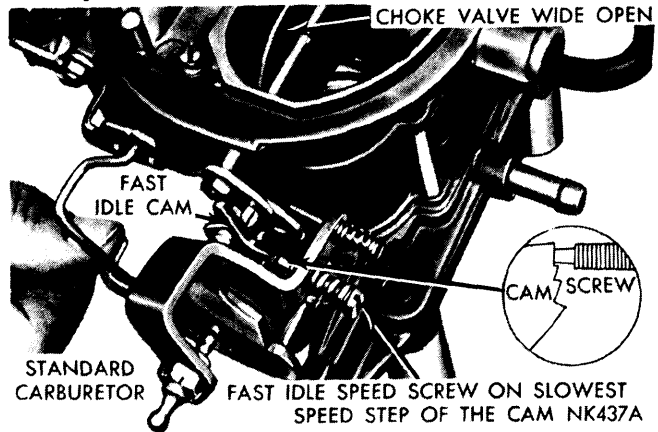

## CARBURETOR ADJUSTMENT SPECIFICATIONS

Stromberg Code No.	Idle Speed (Engine RPM)		Initial Idle Mixture	Fast Idle Cam Position	Float Level Setting	Unloader Setting	Bowl Vent	Accel. Pump Travel	Choke Piston or Vac. Kick	Auto. Choke Setting
	Hot ①	Fast								
3-188	500 ④	1400 ③	1/2-5/8	1/4"	1/8"	1/4"	5/64"	9/16"	.182" ⑤	1 Rich
3-188A	500 ④	1400 ③	1/2-5/8	1/4"	1/8"	1/4"	5/64"	9/16"	.182" ⑤	1 Rich
3-201	500 ④	1400 ③	1 1/2	15/64"	1/8"	15/64"	5/64"	9/16"	.170" ⑤	1 Rich
3-221	500	1400 ③	1 1/2	1/4"	1/8"	15/64"	5/64"	7/16"	.170" ⑤⑥	1 Rich
3-221A	500	1400 ③	1 1/2	1/4"	1/8"	15/64"	5/64"	7/16"	7/64" ⑤	1 Rich
3-242	500	700 ②	1 1/2	1/4"	5/32"	15/64"	1/16"	7/16"	7/32" ⑦	1 Rich
3-244	500	600 ②	1 1/2	17/64"	5/32"	15/64"	1/16"	7/16"	11/64" ⑦	1 Rich
3-254	500	700 ②	1 1/2	#41 Drill	5/32"	15/64"	1/16"	11/32"	#17 Drill ⑦	1 Rich
3-255	500	700 ②	1 1/2	#41 Drill	5/32"	15/64"	1/16"	7/16"	#35 Drill ⑦	1 Rich
3-262	500	700 ②	1 1/2	#38 Drill	5/32"	15/64"	.040"	7/16"	#28 Drill ⑦	2 Rich
3-263	600	1300 ⑤	1 1/2	#38 Drill	5/32"	15/64"	.020"	7/16"	#28 Drill ⑦	Index
3-276	550	700 ②	1 1/2	#42 Drill	5/32"	15/64"	.040"	7/16"	#42 Drill ⑦	2 Rich

① - Auto. Trans. in "N" (Neutral). Air Conditioner ON.

② - With fast idle screw on LOW step of cam.

③ - With fast idle screw on TOP step of cam.

④ - 550 RPM with Air Conditioner ON.

⑤ - Vacuum Piston Setting. .182" (No. 14 Drill), .170" (No. 18 Drill), 7/64" (No. 35 Drill).

⑥ - 7/64" for reworked carburetors. See "Changes, Cautions, Corrections".

⑦ - Vacuum Kick Setting.

⑧ - With fast idle screw on SECOND step of cam (and against shoulder of highest step).

## STROMBERG WWC 2-BARREL (Continued)

with choke valve wide open and fast idle adjusting screw not contacting fast idle cam. Adjust both idle mixture screws equally for maximum engine RPM and smooth idling. Recheck idling speed. If necessary to readjust idle speed, repeat idle mixture adjustment.

**"CAP" Carburetors** - Exhaust Analyser must be used to assure correct fuel mixture setting.

### Fast Idle Speed (On Engine)

**Std. Carburetors** - With hot idle speed correctly adjusted and engine idling at normal operating temperature with transmission in neutral, position fast idle screw on correct step of fast idle cam as listed in specifications, turn fast idle screw in or out for correct fast idle speed (see Specifications).

**"CAP" Carburetors** - **CAUTION** - Ignition timing and Distributor Control Valve Adjustments must be correct before adjusting fast idle speed. See special "CAP" adjustment procedure. With air cleaner in place and engine idling at normal operating temperature, open throttle and position fast idle screw on second step of fast idle cam (see illustration). Turn fast idle screw in or out for correct fast idle speed (see Specifications).

### Fast Idle Cam Position

**1960-63 Carburetors** - Back off throttle stopscrew so that throttle valves tightly closed. Position fast idle cam so that fast idle adjusting screw is on second step of cam and against shoulder of highest step, turn fast idle screw in until it just contacts cam, then turn screw in additional 3½ turns. Move choke valve toward closed position as far as possible with light pressure, measure clearance between upper edge of choke valve and air horn wall using drill or gauge of correct size (see Specifications). If clearance not correct, adjust by bending fast idle connector rod at upper angle. Reset idle speed.

**1964 & Later Carburetors** - Position fast idle cam so that fast idle adjusting screw is on lowest step and against shoulder of next highest step (1964), on second step and against shoulder of highest step (1965 and

later carburetors), of fast idle cam. Move choke valve toward closed position as far as possible with light pressure, measure clearance between upper edge of choke valve and air horn wall using drill or gauge of correct size (see Specifications). If clearance not correct, adjust by bending fast idle connector rod at the upper angle.

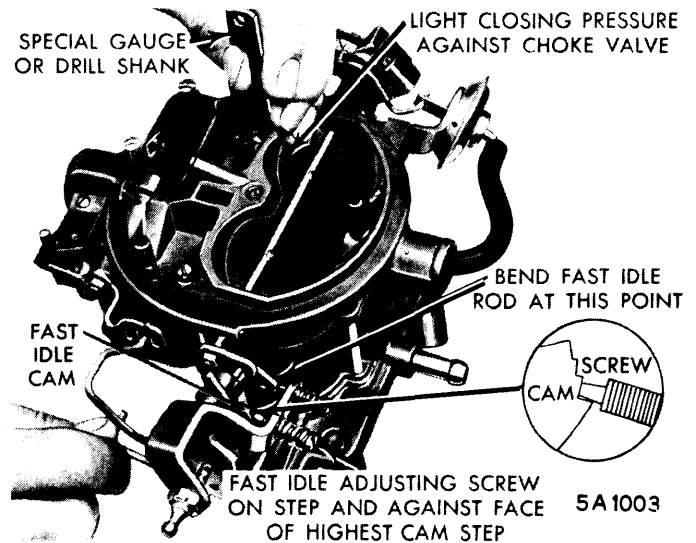

**FAST IDLE CAM POSITION (TYPICAL)**  
(1964 & LATER CARBURETORS)

### Choke Vacuum Piston (1960-63 Carburetors)

On 1960-61-62 carburetors, insert a No. 59 drill (.041") through vacuum passage on underside of choke piston cylinder and engage top groove of vacuum piston. On 1963 carburetors, remove welch plug from end of choke piston cylinder and insert the bent end of a .036-.040" wire gauge (see illustration) into slot in piston wall and rotate hooked end so that it engages end groove in piston. On all models, apply slight closing pressure on choke valve so that drill or gauge hook is gripped

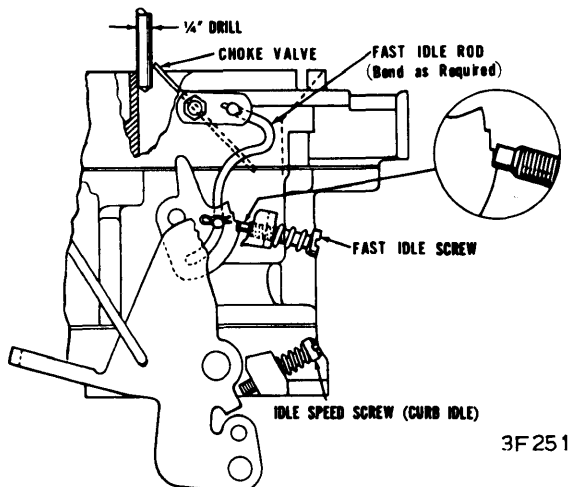

**FAST IDLE CAM POSITION (1960-63 CARBS.)**

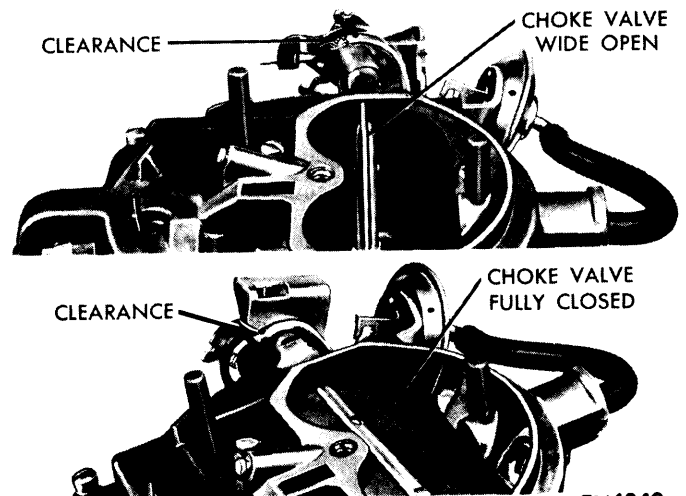

**CHOKE OPERATING LINK CLEARANCE**  
(WITH VACUUM KICK)

## STROMBERG WWC 2-BARREL (Continued)

between piston and end of slot or hole in cylinder wall. Measure clearance between upper edge of choke valve and air horn wall using drill or gauge of correct size (see Specifications). If clearance not correct, adjust by bending ear on choke connector rod bracket on choke valve.

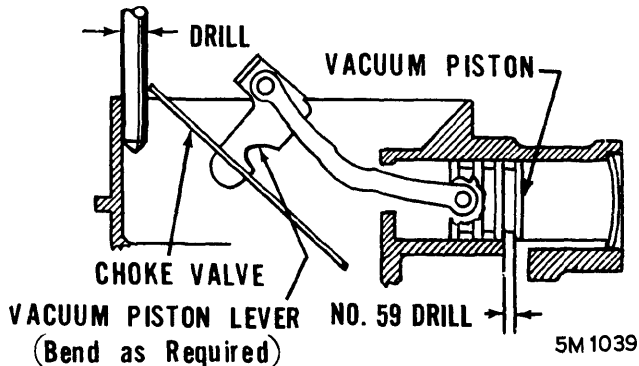

1960-62 CHOKE VACUUM PISTON ADJUSTMENT

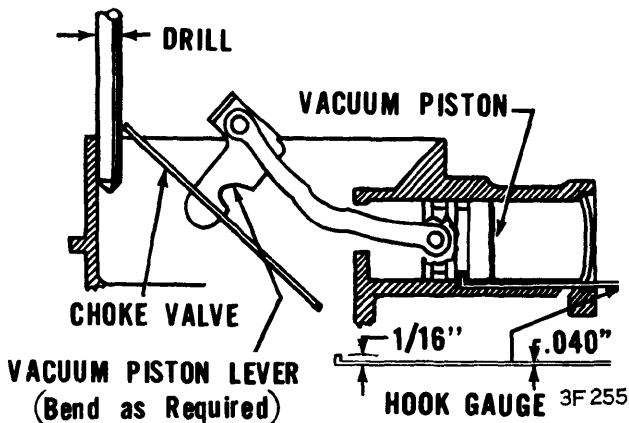

1963 CHOKE VACUUM PISTON ADJUSTMENT

Vacuum Kick (Choke Vacuum Diaphragm)  
(1964 & Later Carburetors)

**All Carburetors - NOTE -** A separate vacuum source (Distributor Tester or another engine) with minimum vacuum of 10" of Hg. must be used to energize the diaphragm for adjustment.

**Checking -** With engine not running, open throttle valve and move choke valve to closed position. Disconnect vacuum hose from diaphragm and connect hose from test vacuum source to this point. Insert a gauge or drill rod of correct size (see Specifications) between edge of choke valve and air horn wall, apply closing pressure on choke shaft lever to provide smallest choke valve opening possible without distorting diaphragm link (**CAUTION - Link must deflect wire spring on lever before it reaches end of travel within slot.**) At this point a slight drag should be noted as gauge is withdrawn from choke valve. If choke opening not correct, adjust as follows:

**Adjustment -** Disengage and remove choke operating link from diaphragm and choke lever (**CAUTION - Damage will result if attempt made to bend link on carburetor.**) Bend operating link at the angle to provide correct choke opening (see illustration). **NOTE - A**

.010" change in link length will change choke valve opening .010" - use a 2" micrometer to check original and adjusted length. Reinstall link and recheck choke valve opening.

**Final Check -** Reinstall vacuum hose on diaphragm fitting. With no vacuum applied to diaphragm, some clearance should exist between choke operating link and choke lever slot in both the open and closed positions (see illustration) to allow full opening and closing of the choke valve. With vacuum applied (engine running), choke valve must have free movement between kick position and wide open choke position. If binding exists, link has been improperly bent. Correct as necessary.

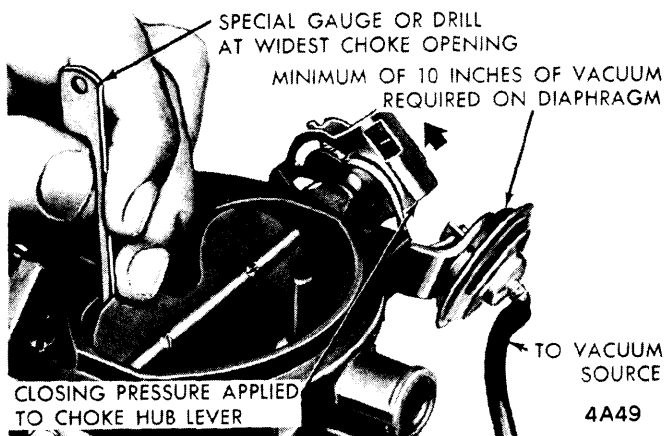

VACUUM KICK SETTING

## Unloader

With choke valve held lightly closed, open throttle valves to wide open position. Clearance between top edge of choke valve and wall of air horn should be correct (see Specifications). Adjust by bending tang (long narrow extension) on throttle lever. Check to make certain throttle valves open fully and close freely with choke valve wide open. (Continued)

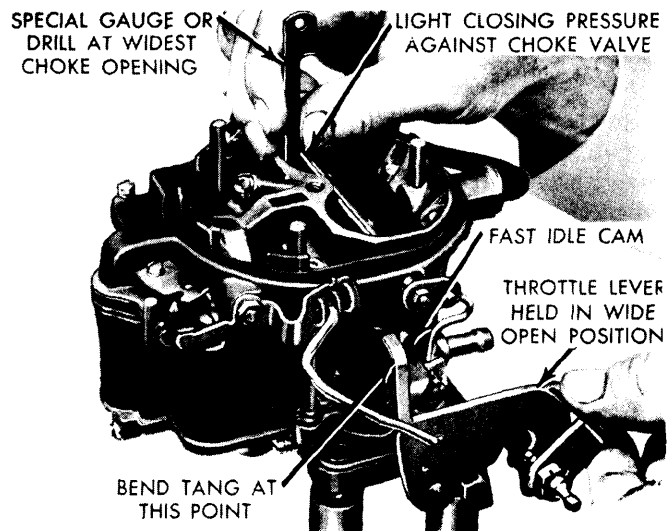

UNLOADER ADJUSTMENT (TYPICAL)

## STROMBERG WWC 2-BARREL (Continued)

### Accelerating Pump

With throttle valves fully closed, pump travel from fully closed to fully open positions should be as indicated in "Specification Table", measured at small raised boss near connecting rod end of pump lever. To adjust, bend pump rod at right angle bend. **NOTE - Pump rod must be installed in center slot of pump arm.**

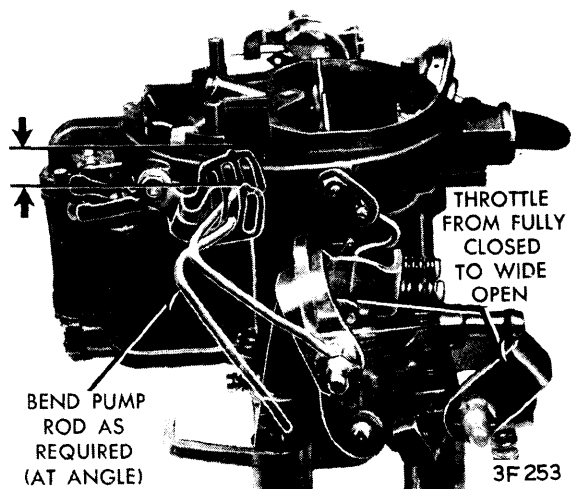

ACCELERATING PUMP ADJUSTMENT

### Bowl Vent

With idle speed screw backed out, hold throttle valves in closed position and choke valve wide open. Opening of vent valve at center of hole with rubber valve hanging free should be as indicated in "Specification Table". To adjust, bend bowl vent lever (extension of accelerating pump lever). **CAUTION - Make sure that vent valve is not distorted and that it properly seals the bowl vent hole when throttle valve is open.**

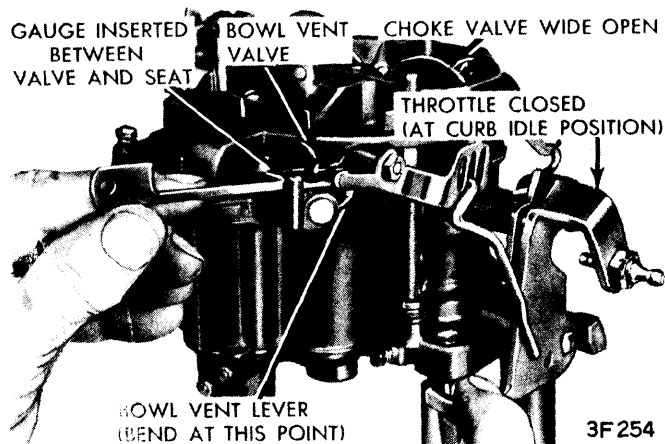

BOWL VENT ADJUSTMENT

### Float Level

With float installed, invert carburetor assembly so that weight of float holds inlet needle valve closed and

make certain hinge pin does not drop out of float hinge (hold down with fulcrum pin spring). **CAUTION - Inlet needle has synthetic rubber tip and excessive closing pressure must not be applied which would compress tip and result in false setting.** Use gauge or "T" scale to measure distance from top edge of fuel bowl to crown of float at center (see Specifications). To adjust, remove float and fulcrum spring and bend float lever tip as required (**CAUTION - Do not attempt to adjust float in carburetor.**). After adjustment, float lip must be perpendicular (within 10°) to top surface of inlet needle.

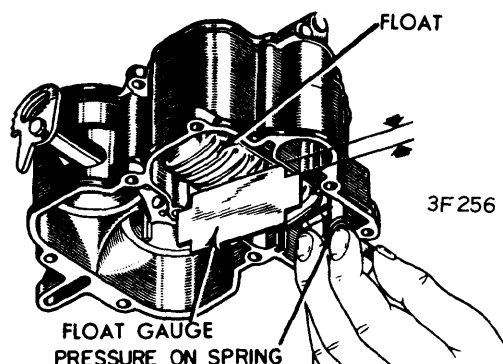

FLOAT LEVEL ADJUSTMENT

### Automatic Choke

Separate "cross-over" or well type mounted in manifold. Should not require adjustment and setting should not be changed except as directed in "Changes, Cautions, Corrections". **NOTE - This unit serviced as an assembly and repair should not be attempted.**

### Spring-Staged Choke

With choke valve closed, press on hub lever with the finger (see illustration), check clearance between shaft lever and hub lever tangs with a feeler gauge. This clearance should be .010-.040". Adjust by bending hub lever tang as required. (Continued)

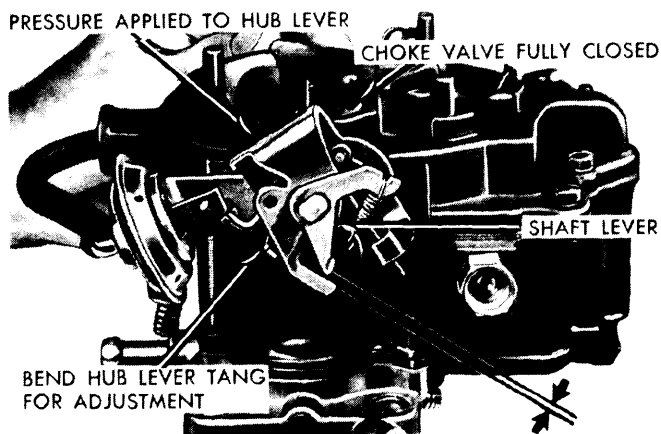

SPRING-STAGED CHOKE ADJUSTMENT

# Stromberg Carburetors

## STROMBERG WWC 2-BARREL (Continued)

### OVERHAUL

#### Disassembly

Remove accelerator pump rod and fast idle rod from carburetor and complete disassembly as follows:

**Air Horn** - Remove air horn attaching screws (install the two short screws through main body into throttle body to hold the bodies together), then remove vacuum diaphragm hose. Remove choke operating link, then remove vacuum diaphragm and bracket assembly. Separate air horn from main body and remove pump plunger and spring (keep plunger in gasoline to prevent leather drying out). Remove vacuum power piston from air horn using an open end wrench and a wood block to pry it out

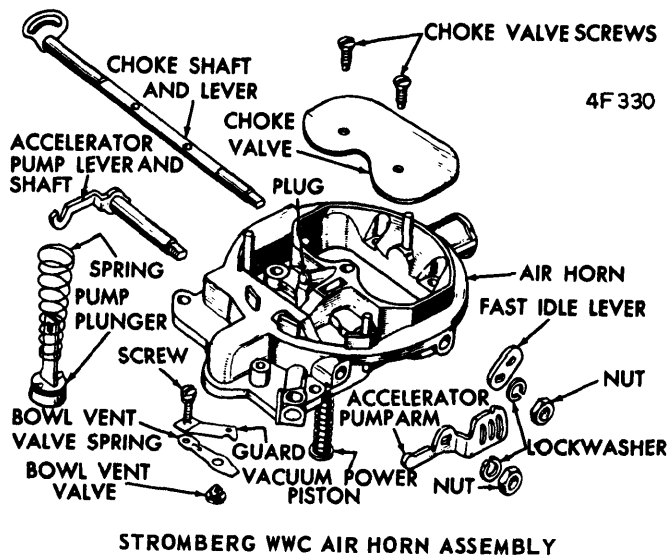

STROMBERG WWC AIR HORN ASSEMBLY

**Main Body** - Remove venturi cluster, then remove float fulcrum pin spring, fuel inlet needle valve, seat and gasket. Remove float baffle, float and fulcrum pin. Invert main body and remove discharge check ball and accelerator pump inlet check ball. Use a suitable tool and remove power bypass jet and main metering jets. Remove the two air horn screws used to hold throttle and main bodies together and separate the throttle body and main body.

**Throttle Body** - Remove idle mixture screws and springs from throttle body. *NOTE - It is not advisable to remove throttle shaft and valves unless necessary to install new parts.* If these parts must be removed, scribe throttle valves along side of throttle shaft and mark valves and throttle body to assure reassembly in same position and barrel, then remove valves, throttle shaft and lever.

#### Reassembly

Reverse disassembly procedure and note the following:

**Throttle Body** - If throttle valves and shaft were removed insert throttle valves in same position in same

barrel that valves were removed from, leaving screws loose. Close throttle, align valves to scribe marks and check for best closing before tightening screws. *NOTE - Throttle valves must be installed with notch toward idle discharge holes.*

**Main Body** - Install accelerator pump inlet check ball (3/16") in pump well and discharge check ball (1/8") in discharge passage.

**Air Horn** - Install vacuum power piston and lock in position by prick punching on retaining rim. Compress piston plunger to make sure no binding exists. If piston sticks or binds enough to cause rough operation, install a new piston assembly.

**Vacuum Kick Diaphragm** - Before installing, check for internal leakage by depressing diaphragm stem and placing finger over vacuum fitting to seal passage, then release stem. If stem moves more than 1/16" in 10 seconds, leakage is excessive and unit should be replaced.

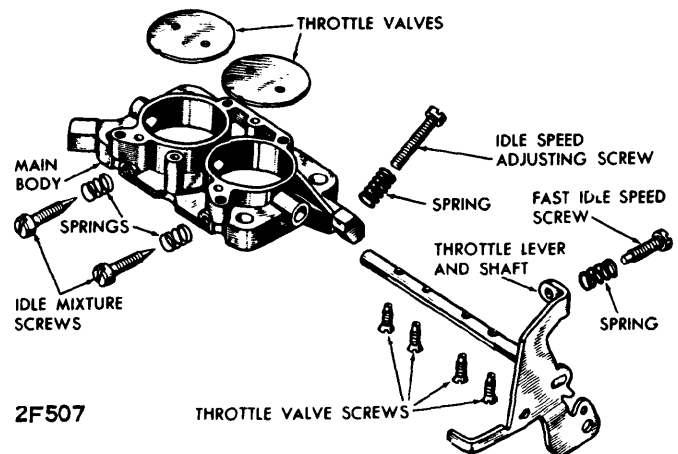

STROMBERG WWC THROTTLE BODY ASSEMBLY

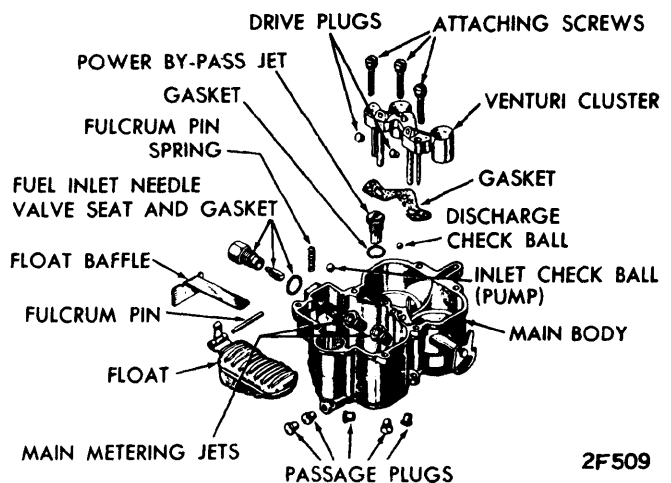

STROMBERG WWC MAIN BODY ASSEMBLY