

# Rochester Carburetors

## ROCHESTER 4 MC & 4MV 4-BARREL

### 1965 MODELS

CHEVROLET	Rochester Carburetor No.		
	Model	Synchro-mesh	Auto. Trans.
396" 325 HP V8 (No A.I.R.)	Early.....	4MV..... 7025201	7025200
	Later.....	4MV..... 7025221	7025220

### 1966 MODELS

BUICK	Rochester Carburetor No.		
	Model	Synchro-mesh	Auto. Trans.
400" V8 (No A.I.R.)	.....	4MC.....	7026242
	(With A.I.R.)	.....	4MC..... 7036242
425" V8 (No A.I.R.)	.....	4MC.....	7026240
	(With A.I.R.)	.....	4MC..... 7036240

### CHEVY II

327" 275 HP V8 (No A.I.R.)	.....	4MV..... 7026203	7026202
	(With A.I.R.)	.....	4MV..... 7036203

### CHEVELLE

327" 275 HP V8 (No A.I.R.)	.....	4MV..... 7026203	7026202
	(With A.I.R.)	.....	4MV..... 7036203

396" 360 HP V8 (No A.I.R.)	.....	4MV..... 7026207	7026206
	(With A.I.R.)	.....	4MV..... 7036207

### CHEVROLET & CORVETTE

327" 275 HP V8 (No A.I.R.)	.....	4MV..... 7026203	7026202
	(With A.I.R.)	.....	4MV..... 7036203

396" 325 HP V8.. (No A.I.R.)	.....	4MV..... 7026201	7026200
	(With A.I.R.)	.....	4MV..... 7036201

427" 390 HP V8 (No A.I.R.)	.....	4MV..... 7026205	7026204
	(With A.I.R.)	.....	4MV..... 7036205

### OLDSMOBILE

330" V8 (No A.I.R.)	.....	4MV..... 7026254	7026254
	(With Air Cond.)	.....	4MV..... 7026255
(With A.I.R.)	.....	4MV..... 7036254	7036254

400" & 425" V8 (No A.I.R.)	.....	4MV..... 7026250	7026250
	(With Air Cond.)	.....	4MV..... 7026256
(With A.I.R.)	.....	4MV..... 7036250	7036250

### PONTIAC TEMPEST

230" 6 Cyl.	.....	4MV..... 7026261	7026260
-------------	-------	------------------	---------

### 1967 MODELS

#### BUICK

400" V8 (No A.I.R.)	.....	4MV..... 7027148	7027146
	(With A.I.R.)	.....	4MV..... 7027149
430" V8 (No A.I.R.)	.....	4MV.....	7027240
	(With A.I.R.)	.....	4MV..... 7027241

#### CADILLAC

Std. (No. A.I.R.)	.....	4MV.....	7027230
	With Air Cond.	.....	4MV..... 7027231
(A.I.R. Cars)	.....	4MV.....	7037230
With Air Cond.	.....	4MV.....	7037231
Eldorado (No A.I.R.)	.....	4MV.....	7027234
With Air Cond.	.....	4MV.....	7027235
(A.I.R. Cars)	.....	4MV.....	7037234
With Air Cond.	.....	4MV.....	7037235
Limousine	.....	4MV.....	7027233

### 1967 MODELS (Continued)

CHEVY II, CHEVELLE, CORVETTE	Rochester Carburetor No.		
	Model	Synchro-mesh	Auto. Trans.

327" 275 HP V8 (No A.I.R.)	Early.....	4MV..... 7027203	7027202
	Later.....	4MV..... 7027213	7027212
(With A.I.R.)	Early.....	4MV..... 7037203	7037202
	Later.....	4MV..... 7037213	7037212

396" 325 HP & 427" 385 HP V8 (No A.I.R.)	Early.....	4MV..... 7027201	7027200
	Later.....	4MV..... 7027211	7027210
(With A.I.R.)	Early.....	4MV..... 7037201	7037200
	Later.....	4MV..... 7037211	7037210

### CAMARO

327" 275 HP & 350" 295 HP V8 (No A.I.R.)	Early.....	4MV..... 7027203	7027202
	Later.....	4MV..... 7027213	7027212
(With A.I.R.)	Early.....	4MV..... 7037203	7037202
	Later.....	4MV..... 7037213	7037212

396" 325 HP V8 (No A.I.R.)	.....	4MV..... 7027211	7027210
	(With A.I.R.)	.....	4MV..... 7037211

### OLDSMOBILE

330" V8 (No A.I.R.)	.....	4MV..... 7027036	7027036
	(K-50 Opt.) <sup>Ⓞ</sup>	.....	4MV..... 7027135
(With A.I.R.)	.....	4MV..... 7027153	7027153

400" & 425" V8 (except Toronado) (No A.I.R.)	.....	4MV..... 7027156	7027156
	(K-50 Opt.) <sup>Ⓞ</sup>	.....	4MV..... 7027032
(With A.I.R.)	.....	4MV..... 7027157	7027157

425" V8 Toronado (No A.I.R.)	.....	4MV.....	7027131
	(K-50 Opt.) <sup>Ⓞ</sup>	.....	4MV..... 7027132
(With A.I.R.)	.....	4MV.....	7027130

### PONTIAC

400" & 428" V8 (No A.I.R.)	.....	4MV..... 7027263	7027262
	(With A.I.R.)	.....	4MV..... 7037263

### TEMPEST

230" 6 Cyl. (No A.I.R.)	.....	4MV..... 7027261	7027260
	(With A.I.R.)	.....	4MV..... 7037261

Ⓞ - "Climatic Combustion Control" option. See Description.

## ► CHANGES, CAUTIONS, CORRECTIONS

► **"A.I.R." CARBURETOR NOTE:** These carburetors are used on engines with Air Injection Reactor exhaust emission control system and are special units with different jet calibrations and specifications.

► **1966 BUICK FUEL SYSTEM LEAK-DOWN TESTING CAUTION (Cars with Rochester 4MC Carbs.):** If test indicates excessive leak-down in carburetor, disassemble carburetor and check for leakage at inlet needle seat diaphragm assembly.

► **1966 BUICK ROUGH IDLE & POOR PERFORMANCE CORRECTION (All Cars with Rochester 4MC Carbs.):** Terne-coated steel plate must be installed between carburetor aluminum throttle body and mounting gasket on intake manifold to seal off exhaust gas in manifold exhaust gas channel (omission of plate will allow exhaust gas to foul up choke housing, leak into intake manifold and

## ROCHESTER 4MC & 4MV 4-BARREL (Continued)

blow out through vacuum advance and crankcase vent lines). When correcting above complaint, make certain plate is installed (plate and gasket can be observed where they project at front corners of carburetor).

- ▶ **1966 BUICK ROCHESTER 4MC CARBURETOR LOOSE THROTTLE LEVER CORRECTION:** If this condition found on early carburetors, correct by installing new Throttle Lever Screw Kit, No. 1396859, as follows: Remove and discard old throttle lever retaining screw, assemble nut on new screw with lockwasher away from screw head, install this assembly on throttle lever, torque screw to 15 in. lbs., then torque locknut to 20 in. lbs. **NOTE** - On later carburetors, screw threads projecting through lever are peened or riveted to prevent screw loosening and no correction required on these carburetors.
- ▶ **1966 BUICK HARD STARTING & LACK OF POWER WITH WARM ENGINE (Cars with Rochester 4MC Carbs.):** May be caused by bent secondary air valve lockout tang resulting in upper offset end of choke rod becoming jammed over the tang (prevents choke closing and secondary air valve opening). Correct by repositioning choke rod offset under the lockout tang, then move choke rod and lockout tang sideways away from each other to remove all slack and bend lockout tang so that it is flush with end of choke rod. Check air valve lockout adjustment (see Adjustments).
- ▶ **1966 BUICK STALLING AFTER STARTING CORRECTION (All Models):** Make certain correct starting technique used (push accelerator pedal to floor once only to allow choke to close and position fast idle cam, do not tap throttle again until engine begins to pick up speed, then tap throttle to position fast idle cam on warm-up step to prevent excessive speed during prolonged warm-up). Check following adjustments: Fast Idle Speed, Fast Idle Cam Position, Vacuum Break Setting (change setting as indicated in Specifications), and Automatic Choke Setting. **NOTE** - For repeated complaints, choke may be set not more than 2 Notches Richer than specified setting (richer setting may result in car not starting in extreme cold weather due to overchoking).
- ▶ **CADILLAC CARBURETOR INSTALLATION CAUTION:** *Stainless steel shim must be installed between manifold gasket and carburetor with side marked "top" upward. Carburetor will not idle if this shim omitted.*
- ▶ **1966 CHEVY II, CHEVELLE, CHEVROLET & CORVETTE HARD COLD STARTING & STALLING AFTER START CORRECTION:** Make certain correct starting technique used (depress accelerator to floor once only to allow choke to close and position fast idle cam, do not hold throttle open or pump throttle for a cold start). Change Vacuum Break Setting as follows: .160" (7026202 & 7036202), .200" (7026203 & 7036202). **NOTE** - This supercedes previous setting of .230" on these carburetors.
- ▶ **1967 OLDSMOBILE V8 HOT ROUGH IDLE CORRECTION (Rochester 4MV Carbs. with Day Stamp between 250 and 285):** If hot rough idle occurs with carburetors with day stamp between 250 and 285 (stamped on left rear corner of throttle body) and without Black Stripe on idle Compensator cover, correct this condition by replacing idle compensator. Correct idle compensator will have pointed valve (incorrect valve has dished center).
- ▶ **1967 OLDSMOBILE V8 ROUGH OR RICH IDLE OR HARD HOT STARTING CORRECTION (Rochester 4MV Carbs. with carburetor tag letter "H" or "J"):** May be caused by plugged left or right idle air bleed. If gasoline fumes are evident or gasoline seepage is noted at ends of primary throttle shaft after engine has been shut off for short time, idle bleeds are probably plugged. To check for this condition, remove air horn and check air bleeds with .042" (1/32") drill. See illustration for air bleed locations.

- ▶ **1966 PONTIAC TEMPEST CARBURETOR LOADING DURING WARM-UP CORRECTION (Sprint Models with Rochester 4MV Carbs.):** Correct by replacing Choke Thermostatic Spring assembly with new type: Part No. 7036190 (Synchro-mesh), 7036191 (Auto. Trans.).

### CARBURETOR IDENTIFICATION

Rochester carburetor number is stamped on round tag in cavity on side of float bowl.

### DESCRIPTION

Four-Barrel downdraft carburetors with automatic choke and large secondary bores incorporating an air valve. The float system, located between primary throttle bores, uses a single, diaphragm assisted, nitrophenyl plastic float. The primary side has small bores and concentric venturi clusters. Idle, power, accelerating pump, metering, choke and fast idle systems operate in primaries. A split type choke allows carburetor to remain on fast idle after choke thermostatic has opened choke valves, and a vacuum break diaphragm controls choke opening in response to manifold vacuum. Fuel metering in primaries is controlled by manifold vacuum operating on tapered metering rods. The large bore secondary side has no venturi clusters, but uses a main discharge nozzle in each bore. Spring-loaded air valves, mounted above the nozzles, open and close in response to air flow past secondary throttle valves. These air valves control metering of fuel in secondaries with a cam linked to tapered secondary metering rods. Model 4MC carburetors have integral automatic choke and vacuum break diaphragm assembly mounted on carburetor. Model 4MV carburetors are used with separate well type automatic choke and have separate vacuum break diaphragm unit mounted on carburetor. Secondary air valve dashpot designs used as follows:

**1965-66 Air Valve Dashpot** - A fuel filled dashpot located in carburetor main body is linked to air valves by a lever and link assembly. See *Air Valve Adjustment*.

**1967 Air Valve Dashpot** - Air valve is linked to vacuum Break diaphragm unit which serves as the air valve dashpot. Connector rod has offset which engages vacuum break lever tang to provide regular choke valve control for starting and engine warm-up.

**Oldsmobile "Climatic Combustion Control"** - This device consists of a thermostatically controlled heated air inlet in the air cleaner (heated air drawn from stove on right hand exhaust pipe) which provides carburetor air temperature of 100°F when underhood temperature is less than 100°F.

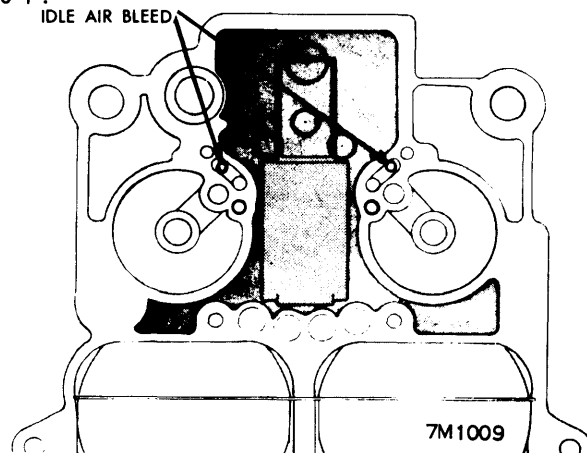

4MV IDLE AIR BLEED LOCATIONS

# Rochester Carburetors

## ROCHESTER 4 MC & 4MV 4-BARREL (Continued)

1965-66 CARBURETOR ADJUSTMENT SPECIFICATIONS (Table No. 1)							
Rochester Carb. No.	Slow Idle Speed (Engine RPM) ①		Fast Idle Speed (Eng. RPM)	Float Level Setting	Pump Rod Setting	Idle Vent Setting	Air Valve Setting
	Synchro-mesh	Auto. Trans.					
7025200	.....	②	2000 ⑦	3/16"	9/32" ⑧	13/32"	1 1/16"
7025201	450-550	.....	2000 ⑦	3/16"	9/32" ⑧	13/32"	1 1/16"
7025220	.....	②	2000 ⑦	3/16"	9/32" ⑧	13/32"	1 1/16"
7025221	450-500	.....	2000 ⑦	3/16"	9/32" ⑧	13/32"	1 1/16"
7026200	.....	450-500 ②	2000 ⑦	1/4"	9/32" ⑧	3/8"	1 1/4"
7026201	450-500	.....	2000 ⑦	1/4"	9/32" ⑧	3/8"	1 1/4"
7026202	.....	450-500 ②	2200 ⑦	1/4"	9/32" ⑧	3/8"	1 1/8"
7026203	450-500	.....	2200 ⑦	1/4"	9/32" ⑧	3/8"	1 1/8"
7026204	.....	500-600 ②	2000 ⑦	1/4"	9/32" ⑧	3/8"	1 1/4"
7026205	500-600	.....	2000 ⑦	1/4"	9/32" ⑧	3/8"	1 1/4"
7026206	.....	500-600 ②	2000 ⑦	1/4"	9/32" ⑧	3/8"	1 1/4"
7026207	500-600	.....	2000 ⑦	1/4"	9/32" ⑧	3/8"	1 1/4"
7026240	.....	500 ④	600 ⑥	1/4"	9/32" ⑧	3/8"	1 3/16"
7026242	.....	500 ④	600 ⑥	1/4"	9/32" ⑧	3/8"	1 3/16"
7026250	⑬	⑭	700 ⑥	11/32"	9/32" ⑧	3/8"	1 1/8"
7026254	600 ③	500 ⑤	700 ⑥	11/32"	9/32" ⑧	3/8"	1 1/8"
7026255	.....	550	700 ⑥	11/32"	9/32" ⑧	3/8"	1 1/8"
7026256	.....	550	700 ⑥	11/32"	9/32" ⑧	3/8"	1 1/8"
7026260	.....	500 ③	.....	7/32"	9/32" ⑧	3/8"	1 1/8"
7026261	600 ③	.....	.....	7/32"	9/32" ⑧	3/8"	1 1/8"
7036200	.....	450-500 ②	2000 ⑦	1/4"	9/32" ⑧	3/8"	1 1/4"
7036201	450-550	.....	2000 ⑦	1/4"	9/32" ⑧	3/8"	1 1/4"
7036202	.....	600 ③	2200 ⑦	1/4"	9/32" ⑧	3/8"	1 1/8"
7036203	700 ③	.....	2200 ⑦	1/4"	9/32" ⑧	3/8"	1 1/8"
7036204	.....	550	2000 ⑦	1/4"	9/32" ⑧	3/8"	1 1/4"
7036205	600	.....	2000 ⑦	1/4"	9/32" ⑧	3/8"	1 1/4"
7036206	.....	550	2000 ⑦	1/4"	9/32" ⑧	3/8"	1 1/4"
7036207	550	.....	2000 ⑦	1/4"	9/32" ⑧	3/8"	1 1/4"
7036240	.....	550 ③	600 ⑥	1/4"	9/32" ⑧	3/8"	1 3/16"
7036242	.....	550 ③	600 ⑥	1/4"	9/32" ⑧	3/8"	1 3/16"
7036250	⑬	⑭	700 ⑥	11/32"	9/32" ⑧	3/8"	1 1/8"
7036254	600 ③	600 ③	700 ⑥	11/32"	9/32" ⑧	3/8"	1 1/8"

- ① - Auto. Trans. in Drive. Air Conditioner ON (Except as noted).  
 ② - Set as low as possible for smooth idling in Drive to prevent creep and harsh shifts in service.  
 ③ - Air Conditioner OFF.  
 ④ - 550 RPM on Air Cond. cars (Air Cond. OFF).  
 ⑤ - 575 RPM on Air Cond. cars (Air Cond. OFF).  
 ⑥ - 600 RPM (400" Eng.), 500 RPM (425" Eng. without Air Cond.), 575 RPM (425" Eng. with Air Cond.). Air Conditioner OFF.  
 ⑦ - Cam follower on LOW step of fast idle cam.  
 ⑧ - Cam follower on HIGH step of fast idle cam.  
 ⑨ - Pump rod in INNER hole of pump lever.  
 ⑩ - 600 RPM (400" Eng.), 550 RPM (425" Eng.) Air Conditioner OFF.

### ADJUSTMENT

- **ADJUSTMENT NOTE:** All adjustments, except Float Level may be made with carburetor installed on engine. On automatic transmission cars, idle speed adjustment must be made with transmission in Drive and idle stator switch closed (stator blades in high angle position). On Air Conditioned Cars, turn Air Conditioner ON (except as noted in Specifications and special notes following).
- **BUICK AUTOMATIC LEVEL CONTROL EQUIPPED CARS CAUTION:** When making idle adjustment, compressor must be disconnected by removing vacuum hose at compressor tank end and plugging this hose.

- **CADILLAC IDLE ADJUSTMENT SETTING CAUTIONS:** Disconnect parking brake vacuum hose at vacuum release cylinder and plug the hose (**CAUTION - Hose must be disconnected at this point so that calibrated leakage of Neutral Safety Switch and other components will not be excluded**). On cars with Automatic Climate Control air conditioning, place control lever in "Auto" position, disconnect and plug vacuum line from power servo on firewall above engine.

(Continued)

## ROCHESTER 4MC & 4MV 4-BARREL (Continued)

1965-66 CARBURETOR ADJUSTMENT SPECIFICATIONS (Table No. 2)							
Carb Rochester Carb. No.	Choke Rod Setting	Split Choke Spring	Vacuum Break Setting	Unloader Setting	Air Valve Lockout	Secondary Throttle Lockout	Auto. Choke Setting
7025200	.150"	.....	.160"	.325"	.....	.015"	⊙
7025201	.150"	.....	.245"	.325"	.....	.015"	⊙
7025220	.120"	.....	.160"	.325"	.....	.015"	⊙
7025221	.150"	.....	.245"	.325"	.....	.015"	⊙
7026200	.100"	.....	.160"	.300"	.015"	.....	⊙
7026201	.100"	.....	.245"	.300"	.....	.015"	⊙
7026202	.110"	.....	.160" ⑩	.245"	.015"	.....	⊙
7026203	.110"	.....	.200" ⑪	.300"	.....	.015"	⊙
7026204	.100"	.....	.160"	.300"	.015"	.....	⊙
7026205	.100"	.....	.245"	.300"	.....	.015"	⊙
7026206	.100"	.....	.215"	.300"	.015"	.....	⊙
7026207	.100"	.....	.275"	.300"	.....	.015"	⊙
7026240	.140"	.....	⊙	.325"	.030"	.....	Index
7026242	.140"	.....	⊙	.325"	.030"	.....	Index
7026250	.120"	.300" ⑫	.170"	.300"	.015-.035"	.....	R ⊙
7026254	.120"	.300" ⑫	.170"	.300"	.015-.035"	.....	R ⊙
7026255	.130"	.300"	.200"	.300"	.015"	.....	R ⊙
7026256	.120"	.300"	.190"	.300"	.015"	.....	R ⊙
7026260	.062"	.300" ⑬	.140"	.300"	.015"	.....	⊙
7026261	.062"	.300" ⑬	.140"	.300"	.015"	.....	⊙
7036200	.100"	.....	.160"	.300"	.015"	.....	⊙
7036201	.100"	.....	.245"	.260"	.....	.015"	⊙
7036202	.110"	.....	.160" ⑩	.260"	.015"	.....	⊙
7036203	.110"	.....	.200" ⑪	.300"	.....	.015"	⊙
7036204	.100"	.....	.160"	.300"	.015"	.....	⊙
7036205	.100"	.....	.245"	.300"	.....	.015"	⊙
7036206	.100"	.....	.215"	.300"	.015"	.....	⊙
7036207	.100"	.....	.275"	.300"	.....	.015"	⊙
7036240	.140"	.....	⊙	.325"	.030"	.....	Index
7036242	.140"	.....	⊙	.325"	.030"	.....	Index
7036250	.120"	.300" ⑫	.170"	.300"	.015-.035"	.....	R ⊙
7036254	.120"	.300" ⑫	.170"	.300"	.015-.035"	.....	R ⊙

⊙ - See text for adjustment procedure.

⑩ - .100" (Step "A"), .200" superseding .230" to correct stalling after start (Step "B").

⑪ - Spring in UPPER notch of bracket.

⑫ - Spring in CENTER notch of bracket.

⑬ - Supersedes previous specification of .230" to correct hard cold starting.

### ADJUSTMENT (Continued)

► **CHEVROLET AUTOMATIC LEVEL CONTROL EQUIPPED CARS CAUTION:** Idle adjustment must be made exactly as follows to prevent rough idle when compressor operating: Adjust level control reservoir pressure to 70 lbs. (use Schrader valve on compressor), adjust idle mixture with compressor operating, then with compressor off (crimp hose or disconnect hose and block vacuum source), check idle speed and adjust as necessary, finally readjust idle mixture for best compromise between compressor operating and compressor not operating conditions.

► **OLDSMOBILE AUTOMATIC LEVEL CONTROL EQUIPPED CARS CAUTION:** When making idle adjustment, automatic level control compressor must NOT be operating.

### Idle Speed & Mixture

**IDLE SETTING CAUTION** - Be sure that idle compensator is closed when adjusting idle speed. If necessary, idle compensator valve may be closed manually. After idle speed is adjusted, press down on idle compensator to see if speed is affected. If speed drops off, readjust idle speed making certain that compensator valve is closed. Adjust idle speed and mixture for each model as follows:

**Buick** - With engine at normal operating temperature and choke valve wide open, adjust throttle stopscrew for correct idle speed (see Specifications), adjust both idle mixture screws evenly for highest engine RPM or vacuum read-

# Rochester Carburetors

## ROCHESTER 4MC & 4MV 4-BARREL (Continued)

1967 CARBURETOR ADJUSTMENT SPECIFICATIONS (Table No. 1)							
Rochester Carb. No.	Slow Idle Speed (Engine RPM) ①		Fast Idle Speed (Eng. RPM)	Float Level Setting	Pump Rod Setting②	Idle Vent Setting	Air Valve Dashpot Setting
	Synchro-mesh	Auto. Trans.					
7027032	⑮	⑰	700 ⑥ ⑫	1/4"	9/32"	3/8"	.030"
7027036	600 ③	500 ⑤	700 ⑥ ⑫	1/4"	9/32"	3/8"	.030"
7027130	.....	500 ⑰	700 ⑥ ⑫	1/4"	9/32"	3/8"	.030"
7027131	.....	500 ⑰	700 ⑥ ⑫	1/4"	9/32"	3/8"	.030"
7027132	.....	500 ⑰	700 ⑥ ⑫	1/4"	9/32"	3/8"	.030"
7027135	600 ③	500 ⑤	700 ⑥ ⑫	1/4"	9/32"	3/8"	.030"
7027146	.....	550 ②	600 ⑫	7/32"	13/32" ⑨	1/2"	.030"
7027147	.....	600 ③	600 ⑫	7/32"	13/32" ⑨	1/2"	.030"
7027148	550 ②	.....	600 ⑫	7/32"	9/32"	3/8"	.030"
7027149	600 ③	.....	600 ⑫	7/32"	9/32"	3/8"	.030"
7027153	650 ③	600 ③	700 ⑥ ⑫	1/4"	9/32"	3/8"	.030"
7027156	⑮	⑰	700 ⑥ ⑫	1/4"	.....	3/8"	.030"
7027157	⑮	⑰	700 ⑥ ⑫	1/4"	9/32"	3/8"	.030"
7027200, 10	.....	⑩	2000 ⑦	9/32"	9/32"	3/8"	.015"
7027201, 11	⑩	.....	2000 ⑦	9/32"	9/32"	3/8"	.015"
7027202, 12	.....	500	2200 ⑦	9/32"	9/32"	3/8"	.015"
7027203, 13	500	.....	2200 ⑦	9/32"	9/32"	3/8"	.015"
7027230	.....	480-500	1700 ⑦	15/64"	11/32" ⑨	.....	.030"
7027231	.....	480-500	1700 ⑦	15/64"	11/32" ⑨	.....	.030"
7027233	.....	480-500	1700 ⑦	15/64"	11/32" ⑨	.....	.030"
7027234	.....	480-500	1700 ⑦	15/64"	11/32" ⑨	.....	.030"
7027235	.....	480-500	1700 ⑦	15/64"	11/32" ⑨	.....	.030"
7027240	.....	550 ②	600 ⑥	9/32"	9/32"	7/16"	.030"
7027241	.....	600 ③	600 ⑥	9/32"	13/32" ⑨	7/16"	.030"
7027260	.....	500 ③	2800 ⑦	7/32"	9/32"	3/8"	.030"
7027261	600 ③	.....	2600 ⑦	7/32"	9/32"	3/8"	.030"
7027262	.....	⑬	2500 ⑦	1/4"	3/16"	3/8"	.030"
7027263	⑮	.....	2500 ⑦	1/4"	3/16"	3/8"	.030"
7037200, 10	.....	⑩	2200 ⑦	9/32"	9/32"	3/8"	.015"
7037201, 11	700 ③	.....	2200 ⑦	9/32"	9/32"	3/8"	.015"
7037202, 12	.....	⑪	2200 ⑦	9/32"	9/32"	3/8"	.015"
7037203, 13	700 ④	.....	2200 ⑦	9/32"	9/32"	3/8"	.015"
7037230	.....	550 ③	1700 ⑦	15/64"	11/32" ⑨	.....	.030"
7037231	.....	550 ③	1700 ⑦	15/64"	11/32" ⑨	.....	.030"
7037234	.....	550 ③	1700 ⑦	15/64"	11/32" ⑨	.....	.030"
7037235	.....	550 ③	1700 ⑦	15/64"	11/32" ⑨	.....	.030"
7037260	.....	600 ③	2800 ⑦	7/32"	9/32"	3/8"	.030"
7037261	700 ③	.....	2600 ⑦	7/32"	9/32"	3/8"	.030"
7037262	.....	600 ③	2500 ⑦	1/4"	3/16"	3/8"	.030"
7037263	700 ③	.....	2500 ⑦	1/4"	3/16"	3/8"	.030"

① - Automatic Trans. in Drive, Air Conditioner ON (except as noted).

② - Set 50 RPM higher on air conditioned cars with Air Conditioner OFF.

③ - Air Conditioner OFF.

④ - Air Conditioner OFF (327" & 350" Engines).

⑤ - 575 RPM on air conditioned cars with Air Conditioner OFF.

⑥ - Cam follower on LOW step of fast idle cam.

⑦ - Cam follower on HIGH step of fast idle cam.

⑧ - Pump rod in INNER hole of pump lever.

⑨ - Pump rod in OUTER hole of pump lever.

⑩ - 500 RPM (396" Eng.), 550 RPM (427" Eng.).

⑪ - 600 RPM with Air Cond. OFF (327" V8 Engine), 500 RPM with Air Cond. ON (350" V8 Engine).

⑫ - 800 RPM on Air Cond. Cars (Air Cond. ON).

⑬ - 500 RPM (400" Eng.), 600 RPM (428" Eng.), with Air Cond. OFF.

⑭ - 600 RPM (400" Eng.), 700 RPM (428" Eng.), with Air Cond. OFF.

## ROCHESTER 4MC & 4MV 4-BARREL (Continued)

1967 CARBURETOR ADJUSTMENT SPECIFICATIONS (Table No. 2)							
Rochester Carb. No.	Choke Rod Setting	Secondary Metering Rod	Vacuum Break Setting	Unloader Setting	Air Valve Lockout	Secondary Throttle Lockout	Auto. Choke Setting
7027032	.140"	7/8"	.200"	.325"	.020"	.....	R ⑮
7027036	.140"	7/8"	.200"	.325"	.020"	.....	R ⑮
7027130	.140"	7/8"	.200"	.325"	.020"	.....	R ⑮
7027131	.140"	7/8"	.200"	.325"	.020"	.....	R ⑮
7027132	.140"	7/8"	.200"	.325"	.020"	.....	R ⑮
7027135	.140"	7/8"	.200"	.325"	.020"	.....	R ⑮
7027146	.130"	27/32"	.200"	.325"	.045"	.....	Notch ⑮
7027147	.130"	27/32"	.200"	.325"	.045"	.....	Notch ⑮
7027148	.130"	27/32"	.215"	.325"	.....	.015"	Notch ⑮
7027149	.130"	27/32"	.215"	.325"	.....	.015"	Notch ⑮
7027153	.140"	7/8"	.200"	.325"	.020"	.....	R ⑮
7027156	.140"	7/8"	.200"	.325"	.020"	.....	R ⑮
7027157	.140"	7/8"	.200"	.325"	.020"	.....	R ⑮
7027200, 10	.100"	27/32"	.160"	.325"	.015"	.....	⑳
7027201, 11	.100"	27/32"	.245"	.325"	.....	.015"	㉑
7027202, 12	.110"	27/32"	.160"	.260"	.015"	.....	㉒
7027203, 13	.100"	27/32"	.200"	.300"	.....	.015"	㉒
7027230	.090"	7/8"	.180"	.300"	.015"	.....	Center ⑮
7027231	.090"	7/8"	.180"	.300"	.015"	.....	Center ⑮
7027233	.090"	7/8"	.180"	.300"	.015"	.....	Center ⑮
7027234	.090"	7/8"	.180"	.300"	.015"	.....	Center ⑮
7027235	.090"	7/8"	.180"	.300"	.015"	.....	Center ⑮
7027240	.130"	53/64"	.200"	.325"	.045"	.....	Notch ⑮
7027241	.130"	53/64"	.200"	.325"	.045"	.....	Notch ⑮
7027260	.085"	53/64"	.245"	.325"	.020"	.....	Center ⑮
7027261	.085"	53/64"	.245"	.325"	.020"	.....	Center ⑮
7027262	.040"	53/64"	.180"	.325"	.020"	.....	Center ⑮
7027263	.090"	53/64"	.230"	.325"	.020"	.....	Center ⑮
7037200, 10	.100"	27/32"	.160"	.325"	.015"	.....	㉑
7037201, 11	.100"	27/32"	.245"	.325"	.....	.015"	㉑
7037202, 12	.110"	27/32"	.160"	.260"	.015"	.....	㉒
7037203, 13	.110"	27/32"	.230"	.300"	.....	.015"	㉒
7037230	.090"	7/8"	.180"	.300"	.015"	.....	Center ⑮
7037231	.090"	7/8"	.180"	.300"	.015"	.....	Center ⑮
7037234	.090"	7/8"	.180"	.300"	.015"	.....	Center ⑮
7037235	.090"	7/8"	.180"	.300"	.015"	.....	Center ⑮
7037260	.085"	53/64"	.245"	.325"	.020"	.....	Center ⑮
7037261	.085"	53/64"	.245"	.325"	.020"	.....	Center ⑮
7037262	.040"	53/64"	.180"	.325"	.020"	.....	Center ⑮
7037263	.090"	53/64"	.230"	.325"	.020"	.....	Center ⑮

- ⑮ - 600 RPM (400" Eng.), 550 RPM (425" Eng. - No Air Cond.), 575 RPM (425" Eng. with Air Cond.), Air Cond. OFF. 500 RPM on Comfortron cars with Comfortron Air Cond. ON.
- ⑯ - 650 RPM (400" Eng.), 600 RPM (425" Eng.) with Air Cond. OFF. 500 RPM on Comfortron cars with Comfortron Air Cond. ON.
- ⑰ - 550 RPM (400" Eng. - No Air Cond.), 600 RPM (400" Eng. with Air Cond.), 500 RPM (425" Eng. No Air Cond.), 575 RPM (425" with Air Cond.), with Air Cond.

OFF. 500 RPM on Comfortron Cars with Comfortron Air Cond. ON.

- ⑱ - 600 RPM (400" Eng.), 500 RPM (425" Eng. - No Air Cond.), 575 RPM (425" Eng. with Air Cond.), Air Cond. OFF. 500 RPM on Comfortron Cars with Comfortron Air Cond. ON.
- ㉑ - Use indicated notch as gauging point, see text for adjusting procedure.
- ㉒ - "Interference" fit of rod. See text for adjusting procedure.

## ROCHESTER 4 MC &amp; 4MV 4-BARREL (Continued)

ing, turn each adjusting screw in until engine speed drops off 20 RPM or vacuum reading drops  $\frac{1}{2}$ ", then turn screw out exactly  $\frac{1}{4}$  turn. If engine speed or vacuum reading has not returned to maximum, continue to turn screw out  $\frac{1}{8}$  turn at a time until maximum speed or vacuum reading is just regained (this "lean side of best idle" setting is particularly important on A.I.R. cars). Recheck idle speed. If necessary to readjust idle speed, repeat idle mixture adjustment.

**Cadillac** - With engine at normal operating temperature and choke valve wide open, adjust throttle stopscrew for correct idle speed (see Specifications), adjust each idle mixture screw alternately and evenly as follows: Adjust mixture screw for highest engine RPM, then turn screw in until engine speed falls off 20 RPM ("lean idle speed fall off" point). On A.I.R. cars, turn screw out exactly  $1\frac{1}{8}$  turns from this lean idle fall off point for final setting. On other engines, turn screw out until engine speed increases and again falls off 20 RPM ("rich idle fall off" point), finally position mixture screw midway between the rich idle and lean idle fall off points. Recheck idle speed. If necessary to readjust idle speed, repeat idle mixture adjustment.

**Chevrolet** - With engine at normal operating temperature and choke valve wide open, adjust throttle stopscrew for correct idle speed (see Specifications), adjust both idle mixture screws evenly for highest steady vacuum and engine speed. On A.I.R. cars, turn each adjusting screw in until engine speed drops off 20-30 RPM ("lean roll" position), then turn screw out exactly  $\frac{1}{4}$  turn for final setting. Recheck idle speed. If necessary to readjust idle speed, repeat idle mixture adjustment.

**Oldsmobile** - With engine at normal operating temperature and choke valve wide open, adjust throttle stopscrew for correct idle speed (see Specifications), adjust both idle mixture screws for smoothest possible idle and highest engine speed and vacuum reading, finally turn each screw out  $\frac{1}{4}$  turn (speed and vacuum will drop off slightly). Recheck idle speed and mixture after air cleaner installed.

**Pontiac & Tempest** - With engine at normal operating temperature and choke valve wide open, adjust throttle stopscrew for correct idle speed (see Specifications), adjust both idle mixture screws for highest engine speed and vacuum. Recheck idle speed. If necessary to readjust idle speed, repeat idle mixture adjustment.

## Fast Idle Speed (On Engine)

With engine at normal operating temperature, position fast idle cam follower on correct step of fast idle cam as indicated in the specifications, adjust fast idle screw for specified engine fast idle RPM (see Specifications).

## Slow-Closing Throttle Dashpot &amp; Idle Speed-Up Controls

See CARBURETOR on car model Tune-Up pages for adjustment of these units (when used).

## Float Level

**NOTE** - This is an "Off-Car" adjustment. Measure from top of float bowl gasket surface with gasket removed to top of float at toe end with gauging point  $\frac{1}{16}$ " back from toe radius (supersedes previous  $\frac{3}{16}$ " gauging point). **CAUTION** - Do not position gauge over float mold numbers - these numbers will be relocated on later floats. Make certain retaining pin is held firmly in place and tang of float is seated in float needle. Distance from float toe to gasket surface of bowl should be as specified (see Specifications). Adjust by bending float up or down as necessary (see illustration).

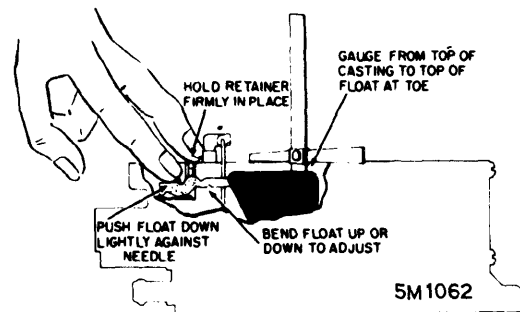

FLOAT LEVEL ADJUSTMENT

## Pump Rod

Make certain pump rod connected in correct hole of pump lever (see Specifications). With throttle valves completely closed, measure from top of choke valve wall (next to vent stack) to top of pump stem. Distance should be as specified in Specification table. Adjust by bending pump lever as follows: Wedge lever with a screwdriver, tighten a crescent wrench securely on lever and bend lever downward (if specification too small), bend lever upward (if specification too large). **CAUTION** - To make certain throttle valves are completely closed when checking pump rod, it is recommended that actuating link between primary and secondary throttle lever be disconnected for this check.

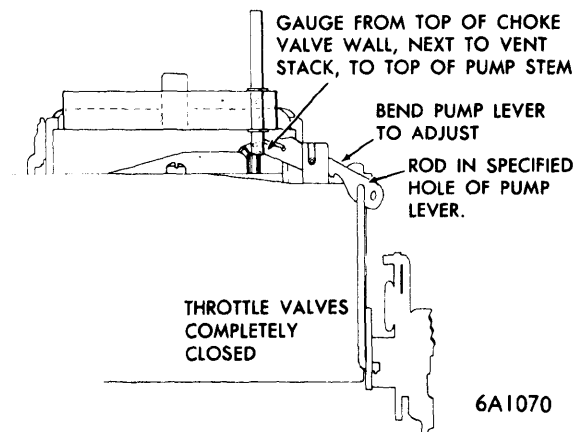

PUMP ROD ADJUSTMENT

## Idle Vent Adjustment

With pump rod adjustment completed, open primary throttle valves to a point where idle vent just closes. Distance from top of choke valve wall next to vent stack to top of pump plunger stem should be as specified. Bend wire tang on pump lever to adjust; see illustration. (Continued)

## ROCHESTER 4MC & 4MV 4-BARREL (Continued)

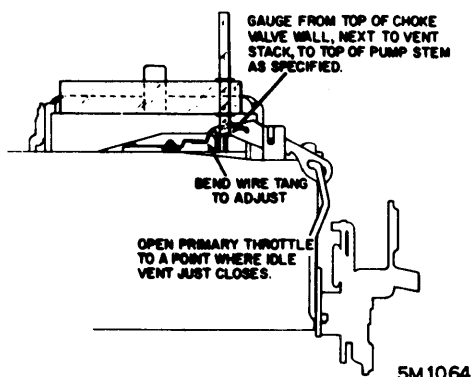

IDLE VENT ADJUSTMENT

### Fast Idle Setting (Off Engine)

With primary throttle valves completely closed and cam follower positioned on high step of fast idle cam, turn fast idle screw in until it makes contact with lever, then turn screw in additional 3 turns (All 1965-66 carburetors and 1967 Chevrolet, Pontiac, Tempest), 1 turn (1967 Cadillac). This is a preliminary setting only. See "Fast Idle Speed (On Engine)" for final adjustment.

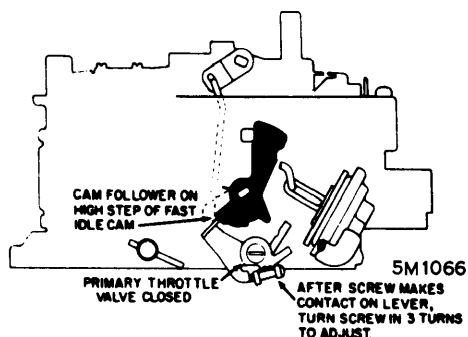

FAST IDLE SETTING (OFF ENGINE)

### Choke Rod

With fast idle adjustment completed and cam follower on second step of fast idle cam and against high step (see illustration), rotate choke valve toward closed position by pressing down on thermostatic coil lever tang (4MC carburetors) or by pressing down on vacuum break lever tang and pushing down on lower edge of choke valve to make certain that connector rod is at bottom of slot in choke valve lever (4MV carburetors). Measure clearance between

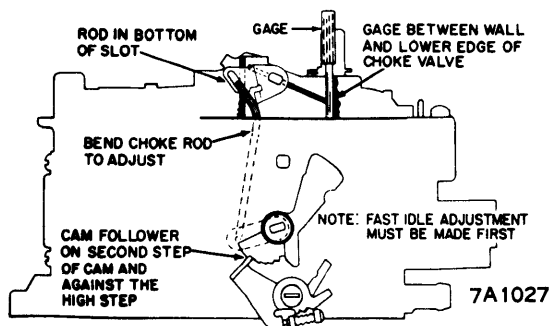

CHOKE ROD ADJUSTMENT

lower edge of choke valve and air horn wall at choke lever end. If this clearance not correct (see Specifications), adjust by bending choke rod (see illustration).

### Air Valve (1965-66 Carburetors)

NOTE - See Air Valve Dashpot adjustment for 1967 carburetors.

With air valve wide open (against stop tang), distance between upper inside edge of air valve and back of choke valve wall (at torsion spring end) should be as specified in table. Bend stop tang on dashpot lever to adjust.

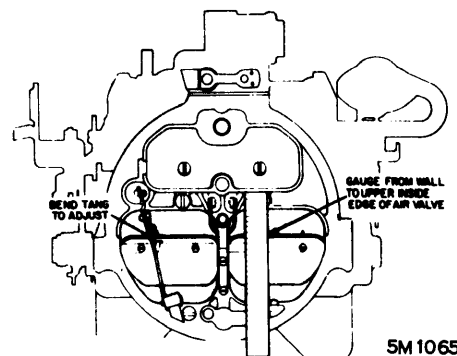

1965-66 AIR VALVE ADJUSTMENT

### Air Valve Dashpot (1967 Carburetors)

CAUTION - Air Valve Dashpot must be adjusted before checking and adjusting Vacuum Break.

NOTE - Air valve dashpot is same vacuum diaphragm unit used for Vacuum Break operation (above). With vacuum break diaphragm stem inward against its seat (see Vacuum Break adjustment above), and with air valve closed in normal position, check clearance between connector rod and end of slot in air valve lever. If clearance not correct (see Specifications), adjust by bending connector rod at existing bend at air valve end (see illustration).

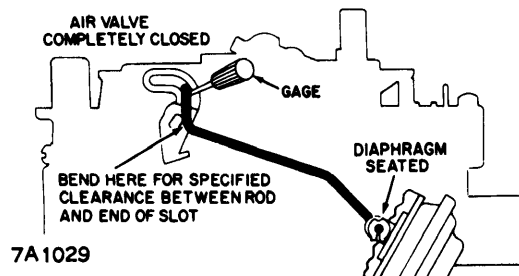

1967 AIR VALVE DASHPOT ADJUSTMENT

### Vacuum Break (4MC Carbs.)

Remove thermostatic cover and coil assembly and baffle. Two adjustments required (see illustration):

Step "A" - With choke valve closed and choke rod at bottom of slot in choke shaft lever, align thermostatic coil pick-up tang directly over index tab on inside of choke housing (see illustration), measure clearance between vacuum break tang on choke lever and end of vacuum break

## ROCHESTER 4MC &amp; 4MV 4-BARREL (Continued)

plunger pin (see Specifications). Adjust by bending vacuum break tang as required.

**Step "B"** - With vacuum break diaphragm seated (plunger pin extended) and choke rod at bottom of slot in choke shaft lever, measure clearance between lower edge of choke valve and air horn wall (see Specifications). Adjust by turning adjusting screw on vacuum break cover as necessary. Install baffle plate and thermostatic cover and coil assembly, adjust automatic choke setting.

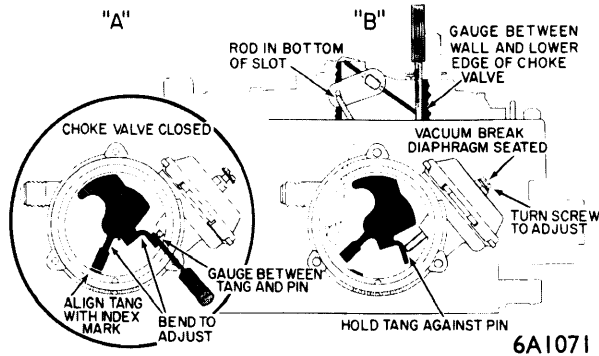

VACUUM BREAK ADJUSTMENT (4MC CARBS.)

### Vacuum Break (1965-66 4MV Carburetors)

Make certain that choke spring pick-up located in specified notch of vacuum break bracket (see Specifications). Hold choke valve toward closed position with a rubber band on vacuum break lever, hold vacuum break diaphragm stem against its seat so that vacuum link is at end of slot. Distance between lower edge of choke valve and air horn wall (at choke lever end) should be as specified in Specification table. Adjust by bending vacuum link.

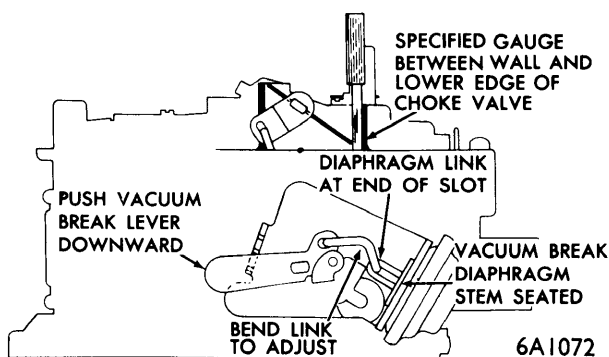

VACUUM BREAK ADJUSTMENT (1965-66 4MV CARBURETORS)

### Vacuum Break (1967 4MV Carburetors)

**CAUTION** - Adjust Air Valve Dashpot first, then check and adjust Vacuum Break as follows:

Hold vacuum break diaphragm stem inward against its seat (an outside vacuum source of at least 6" of Hg. connected to vacuum break diaphragm fitting can be used to

hold stem depressed). Push up lightly on vacuum break lever until lever tang contacts vacuum break rod and move choke valve toward closed position so that choke rod is at bottom of slot in choke valve lever. Measure clearance between lower edge of choke valve and air horn wall at choke lever end. If this clearance not correct (see Specifications), adjust by bending vacuum break lever tang as required (see illustration).

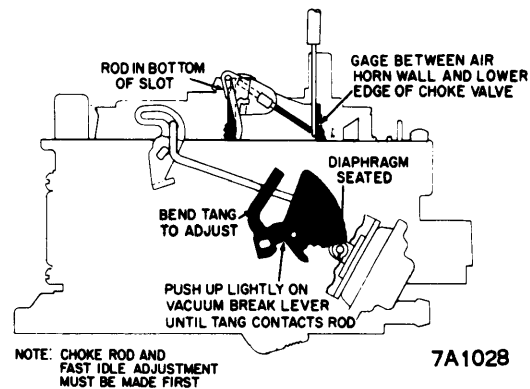

VACUUM BREAK ADJUSTMENT (1967 4MV CARBURETORS)

### Split Choke Spring (1966 4MV Carbs.)

**NOTE** - This adjustment not required on Chevrolet carburetors. Make certain split choke spring end engaged in correct notch of vacuum break bracket as indicated in specifications, open choke valve by pressing upward on vacuum break lever to end of travel and make certain choke rod is at upper end of slot in choke lever. Check dimension between end of torsion spring and tang on lever (see illustration and Specifications). Adjust by bending tang as necessary.

**NOTE** - On Pontiac Tempest, after split choke spring adjustment completed, engage choke spring end in center notch of vacuum break bracket (this is correct operating position).

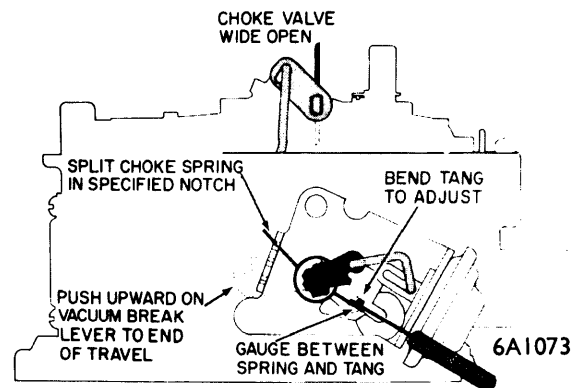

1966 SPLIT CHOKE SPRING ADJUSTMENT

### Unloader

With choke valve held closed by a rubber band on vacuum break lever, open primary throttle to wide open position. With valves held open, dimension between lower edge of

## ROCHESTER 4 MC & 4MV 4-BARREL (Continued)

choke valve and air horn wall should be as specified in table. Bend tang on fast idle lever to adjust.

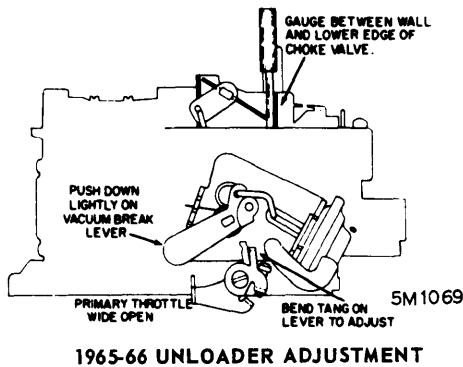

1965-66 UNLOADER ADJUSTMENT

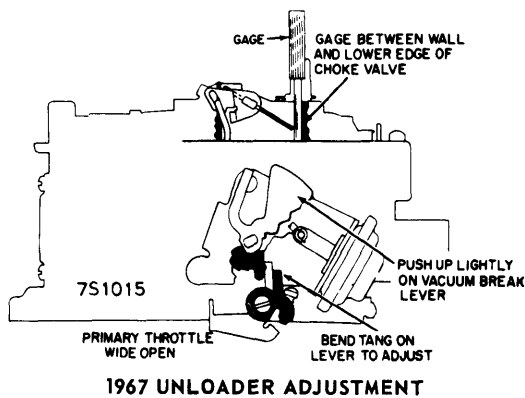

1967 UNLOADER ADJUSTMENT

### Air Valve Lockout (Buick, Cadillac, Chevrolet, Pontiac)

**NOTE** - This adjustment not required on Buick or Chevrolet Synchro-mesh Transmission Cars (see Secondary Throttle Lockout).

**Opening Clearance** - With choke valve wide open, apply sufficient force to vacuum break lever or thermostat tang to move choke rod to top of slot in choke lever, move air valve in direction of open valve, bend upper end of air valve lockout lever as required to obtain specified opening (see Specifications) between lockout tang and front edge of air valve.

**1966 Lockout Action** - With the cam follower against the rise to lowest effective step of fast idle cam, apply light force to vacuum break lever or thermostat tang in direction of closed choke, rotate choke valve to its wide open stop by applying force to up side of valve and make certain choke rod is at bottom of slot in choke lever. Move air valve in direction of open valve. Air valve must be locked closed. If adjustment required, recheck opening clearance.

**1967 Lockout Action** - Rotate choke valve to its wide open stop by applying force to up side of valve and make certain choke rod is at bottom of slot in choke lever. Move air valve in direction to open valve. Air valve must be locked closed. If adjustment required, recheck opening clearance.

**NOTE** - On Cadillac, air valve will be limited to an 8° opening (wide open throttle with choke operating) in this lockout position.

### Air Valve Lockout (Oldsmobile)

**Opening Clearance** - With the cam follower positioned against rise to lowest step of fast idle cam, apply light force to vacuum break lever in direction of closed choke,

rotate choke valve to its wide open stop by applying force on up side of choke valve so that choke rod is at bottom of slot in choke lever. Move air valve in direction of open valve, bend upper end of air valve lever as required to obtain specified opening (see Specifications) between lockout tang and front edge of air valve.

**Lockout Action** - After checking clearance (above), rotate choke valve in direction of closed choke so that choke rod is at upper end of slot in choke lever. Move air valve in direction of open valve. Air valve must be locked closed. If adjustment required, recheck opening clearance.

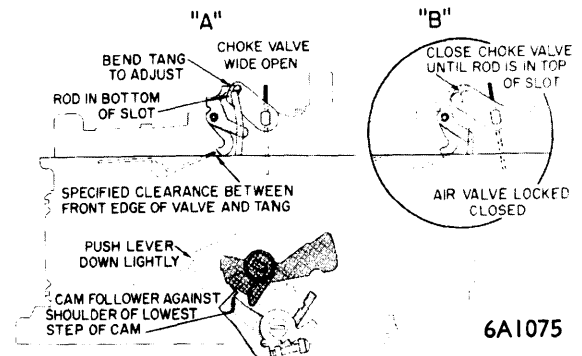

AIR VALVE LOCKOUT ADJUSTMENT (OLDSMOBILE)

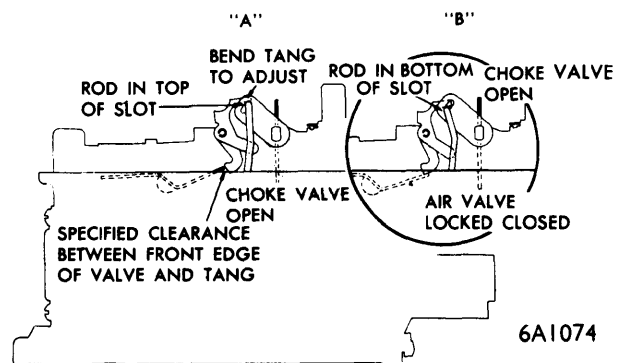

AIR VALVE LOCKOUT ADJUSTMENT (BUICK, CHEVROLET, PONTIAC)

### Secondary Throttle Lockout

With choke valve and both primary and secondary throttle valves fully closed, check clearance between lockout lever and lockout pin on secondary throttle shaft. Lever should not contact pin and clearance must not exceed specified figure (see Specifications). Adjust by bending lockout pin as necessary. (Continued)

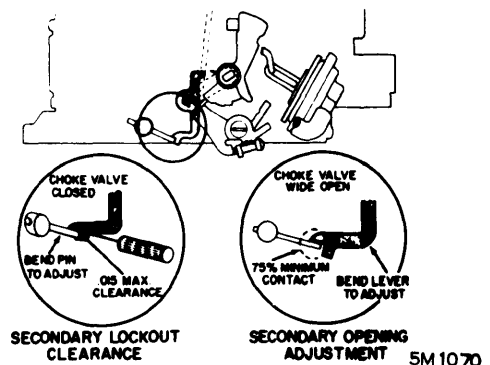

SECONDARY THROTTLE LOCKOUT ADJUSTMENT

## ROCHESTER 4MC &amp; 4MV 4-BARREL (Continued)

Secondary Throttle Opening  
(1965-66 Carburetors)

Holding choke valve and primary throttle valves wide open and secondary throttle valves closed, lock-out pin should have a minimum of 75% contact on lock-out lever. To adjust, bend lock-out lever.

**Buick & Pontiac Tempest** - Check for full opening of secondary throttle valves as follows: Open primary throttle valves until actuating link just contacts tang on secondary lever. At this point, bottom of link should be in center of slot in secondary lever. Adjust by bending tang on secondary lever as necessary.

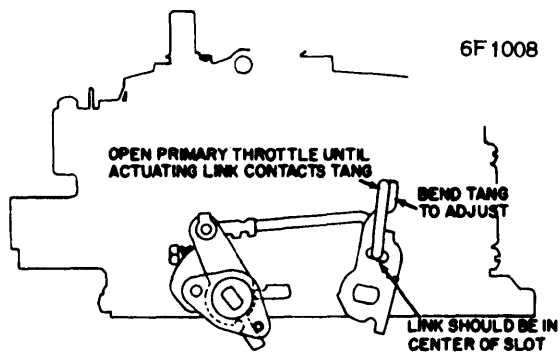

1965-66 SECONDARY OPENING ADJUSTMENT

Secondary Throttle Opening  
(1967 Carburetors)

This adjustment required to ensure proper opening of secondary throttle valves. Open primary throttle valves until actuating link just contacts tang on secondary throttle lever (see illustration). At this point, bottom of link should be centered in slot on secondary lever (except Oldsmobile - see Note below). Adjust by bending tang on secondary lever as required.

**Chevrolet Note** - Early type carburetors are adjusted as above. Check and adjust later type carburetors as follows:

**Chevrolet 1967 Later Type Carburetors** - Open primary throttle valves until actuating link contacts extended tang on secondary lever. At this point, bottom of link should be in center of secondary lever slot and there should be .070" clearance between link and tang (see illustration). Adjust by bending tang on secondary lever.

**Oldsmobile Note** - On all 1967 Oldsmobile carburetors, clearance between link and tang at point illustrated should be .070".

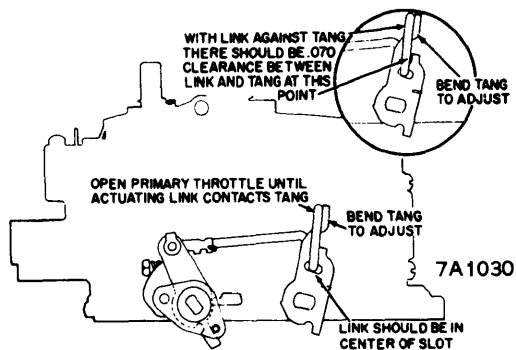

1967 SECONDARY OPENING ADJUSTMENT

## Secondary Throttle Closing

This adjustment required to ensure proper closing of secondary throttle valves. With primary throttle valves closed in correct curb idle position (see Idle Speed Adjustment) and with cam follower not contacting fast idle cam, check clearance between actuating link and front of slot in secondary lever when tang on Primary actuating lever is against pin (see illustration). This clearance should be .020" (all carburetors). Adjust by bending tang on primary actuating lever as required.

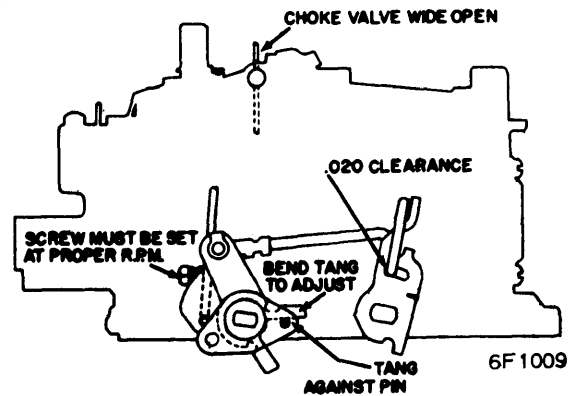

1965-66 SECONDARY CLOSING ADJUSTMENT

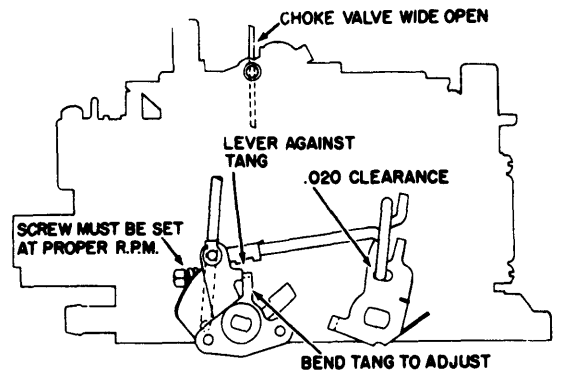

1967 SECONDARY CLOSING ADJUSTMENT

## Secondary Metering Rod

Check adjustment by measuring from top of each metering rod to top of air horn casting adjacent to air cleaner stud hole. If this dimension not correct (see table below), adjust by bending metering rod hanger at point shown (see

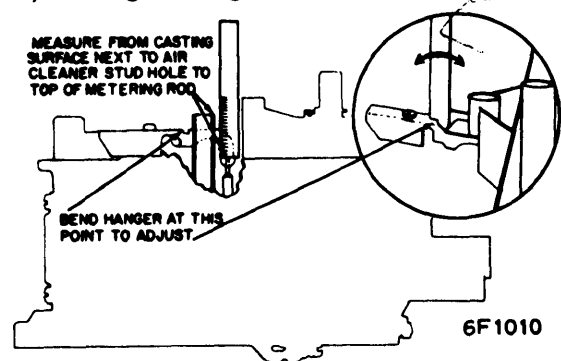

SECONDARY METERING ROD ADJUSTMENT

## ROCHESTER 4MC & 4MV 4-BARREL (Continued)

illustration). **CAUTION** - Both metering rods must be adjusted evenly.

### Secondary Metering Rods

Car Model	Metering Rod Dimension
1966 Buick All Carbs.	53/64"
1967 Buick 7027240, 7027041	53/64"
All Other Carbs.	27/32"
1967 Cadillac All Carbs.	7/8"
1965 Chevrolet All Carbs.	27/32"
1966 Chevrolet 7026200, 01, 04, 05	27/32"
7036200, 01, 04, 05	27/32"
All Other Carbs.	53/64"
1967 Chevrolet All Carbs.	27/32"
1966-67 Oldsmobile All Carbs.	7/8"
1966-67 Pontiac & Tempest All Carbs.	53/64"

### Secondary Air Valve Spring Wind-up

If adjustment required, use 1/16" Allen wrench to loosen lock screw, turn adjusting screw counterclockwise until all spring tension removed. Hold air valve closed and turn adjusting screw clockwise until torsion spring just contacts pin in shaft, then wind-up spring by continuing to turn adjusting screw clockwise the exact amount shown in table below. Hold adjusting screw in this position and tighten lock screw securely.

### Air Valve Spring Setting

Car Model	Adjusting Screw Turns
1966 Buick All Carbs.	5/8
1967 Buick All Carbs.	1/2
1967 Cadillac All Carbs.	7/8
1965-66 Chevrolet All Carbs.	1
1967 Chevrolet All Carbs.	7/8
1966 Oldsmobile 330" Eng. 7026254, 7036254	1/2
330" Eng. 7026258	5/8
400" & 425" Eng. All Carbs.	3/4
1967 Oldsmobile 330" Eng. All Carbs.	5/8
400" & 425" Eng. All Carbs.	3/4
1966-67 Pontiac & Tempest All Carbs.	1/2

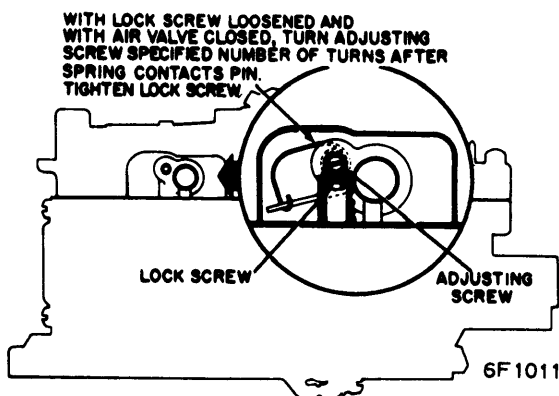

SECONDARY AIR VALVE SPRING WIND-UP

### Automatic Choke (4MC Carburetors)

Loosen choke cover retaining screws and rotate cover and thermostatic coil assembly to align reference mark on cover with correct graduation of scale on housing (see Specifications). **NOTE** - For centered "Index" setting, align cover mark with center mark of housing scale.

### Automatic Choke Coil Rod (4MV Carburetors)

**1967 Buick** - With operating rod disconnected from choke lever, hold choke valve completely closed with upward pressure on lever, pull upward on choke operating rod to end of travel. End of rod should fit freely in gauging slot on edge of lever. Adjust rod length by bending at the rod loop. Connect rod in lever hole marked "STD" except on A.I.R. cars or all cars operated at altitudes above 3500 ft. in which case rod should be connected in hole marked "ALT".

**1967 Cadillac** - Choke assembly must be removed from manifold to disengage connector rod from vacuum break lever for adjustment (temporarily install coil assembly with rod disconnected for gauging operation, then connect rod and reinstall coil assembly). Close choke valve completely by pressing upward on vacuum break lever, pull choke connector rod upward to end of travel. At this point, rod end should fit freely in center notch on side of lever (midway between "L" and "R" notches). Adjust by bending the rod at the existing bend.

**1965 Chevrolet** - Disconnect automatic choke rod from vacuum break lever. With choke valve completely closed and choke rod at bottom of slot in choke lever, pull up on choke coil rod to limit of its travel. In this position, bottom of rod end should be even with top of hole in vacuum break lever. Adjust by bending the rod as necessary. Connect rod and install clip. **CAUTION** - Rod end must be square and enter vacuum break lever hole freely.

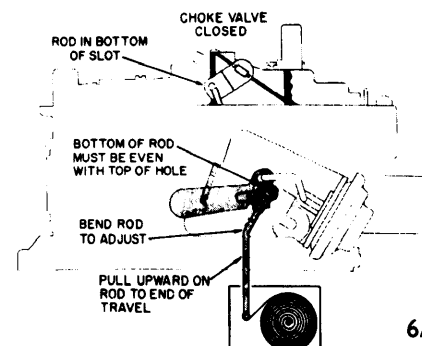

AUTOMATIC CHOKE ROD ADJUSTMENT (1966 CHEVROLET & PONTIAC)

**1966-67 Chevrolet** - Disconnect choke rod from the vacuum break lever, close choke valve completely by pressing on vacuum break lever, check choke connector rod length for each engine as directed below. Adjust rod by bending at the offset (rod end must be square and enter lever hole freely).

**327" 275 HP & 350" 295 HP V8** - Press rod downward to end of travel. At this point, top of rod end should be 1/2-rod diameter below top of hole in lever.

**All Other Engines** - Pull rod upward to end of travel. At this point, top of rod end should be 1/2-rod diameter above top of hole in lever.

**1966 Oldsmobile** - Disconnect choke rod from vacuum break lever. With choke valve completely closed and choke rod at bottom of slot in choke lever, pull forward on choke coil rod until rod is against stop in choke coil cover. At this point, rod end should freely fit in upper "R" notch on end

## ROCHESTER 4MC &amp; 4MV 4-BARREL (Continued)

of vacuum break lever (see Note below). Adjust by bending outer loop of rod as necessary for correct fit, then connect rod and install clip.

**OLDSMOBILE VACUUM BREAK LEVER NOTE** - Lever has three notches on outer end for gauging of choke coil rodlength as follows: Upper "R" (rich), Center, Lower "L" (lean). Rod end should freely engage correct notch.

**1967 Oldsmobile** - Disconnect choke rod from the vacuum break lever, close choke valve completely by pressing on vacuum break lever, pull forward on connector rod until rod contacts stop in choke housing. At this point, rod end should fit freely in "R" notch on side of lever. Adjust by bending the rod at the offset. **NOTE** - Choke rod on Toronado carburetors is GOLD with loop at end, rod on all other carburetors is BLACK with offset at end.

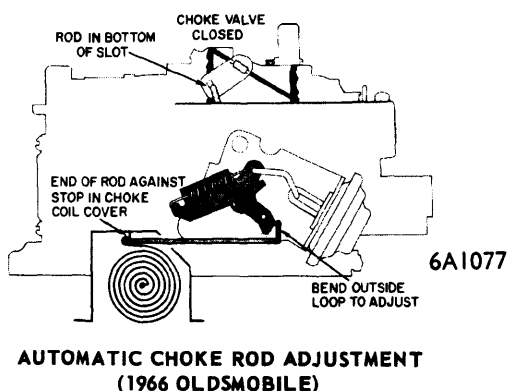

**1966 Pontiac Tempest** - Disconnect the carburetor choke coil rod from hole in vacuum break lever, hold choke valve completely closed and push downward on vacuum break lever, pull outward on choke rod to limit of its

travel. Inner side of choke rod should be 1/2 hole diameter beyond outer side of hole in vacuum break lever. Adjust by bending rod at existing bend on thermostatic coil end of rod. Connect rod.

**1967 Pontiac & Tempest** - With choke rod disconnected from vacuum break lever, close choke valve completely by pressing upward on vacuum break lever, pull upward on connector rod until rod contacts stop in choke housing. At this point, rod end should fit freely in center notch on upper side of vacuum break lever counterweight (see illustration). Adjust by bending connector rod at the offset.

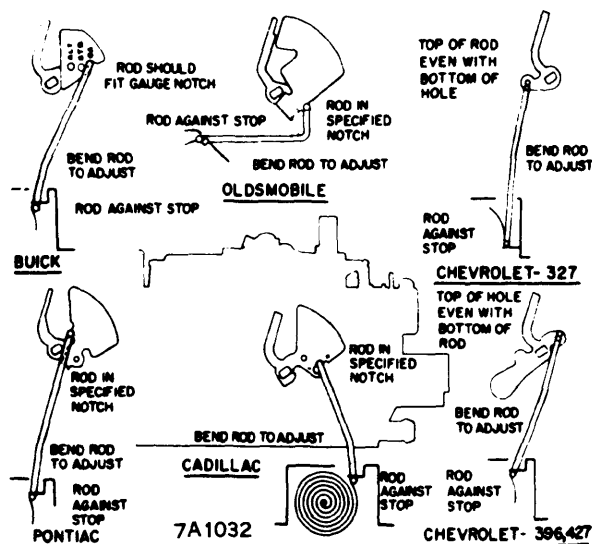

## OVERHAUL

**NOTE** - Overhaul of Model 4MC and 4MV carburetors is the same except for automatic choke and vacuum break assemblies as detailed under Float Bowl disassembly below.

## Disassembly

**Air Horn** - Remove idle vent valve assembly. Disconnect choke rod from upper choke shaft lever and pump rod from pump lever. Remove air horn-to-bowl attaching screws (2 screws are next to primary venturi), and remove air horn by lifting straight up. Air horn gasket should remain on bowl. **CAUTION** - Be careful not to bend two small main well air bleed tubes pressed into air horn. **DO NOT REMOVE**. Hold air valve wide open, then tilt and slide secondary metering rods from holes in hanger. Disconnect dashpot from air valve link by rotating bend through hole in lever, then remove dashpot from air horn by rotating bend through air horn. **NOTE** - Further disassembly of air horn is not required for cleaning. If parts replacement is required, proceed as follows: Take out choke valve attaching screws, remove choke valve and shaft. Remove pump lever roll pin, remove pump lever. **CAUTION** - Air valves, air valve shaft, and secondary metering rod hanger are calibrated and must not be removed. If damaged, replace air horn assembly.

**Float Bowl** - Remove pump plunger from pump well. Remove air horn gasket from dowels on secondary side, then remove gasket from around power piston and primary metering rods. Remove pump return spring from pump well, plastic filler over float valve, and power piston and main metering rods (use needle nosed pliers to pull straight up on metering rod hanger directly over power piston). Remove power piston spring, disconnect tension spring from top of each metering rod, rotate rods and remove from hanger. Remove float assembly by pulling up slightly on retaining pin to remove pin, then slide float assembly toward front of bowl to disengage needle pull clip. **NOTE** - Be careful not to distort pull clip. Remove float needle retainer and needle assembly. **CAUTION** - Needle seat is factory staked and should not be removed or restaked. If damaged, replace float bowl. Remove pull clip and retainer from needle and remove primary metering jets. **CAUTION** - Do not remove secondary metering discs. Remove pump discharge check ball retainer and check ball, remove baffle from secondary side of bowl. On 4MV Carburetors, remove vacuum hose from tube connection on bowl and from vacuum break assembly, remove retaining screw from choke assembly and remove assembly from float bowl (**NOTE** - If further disassembly of choke is necessary, remove clip from vacuum break link at vacuum break lever and remove rod, spread retaining ears on bracket next to vacuum break assembly

## ROCHESTER 4MC & 4MV 4-BARREL (Continued)

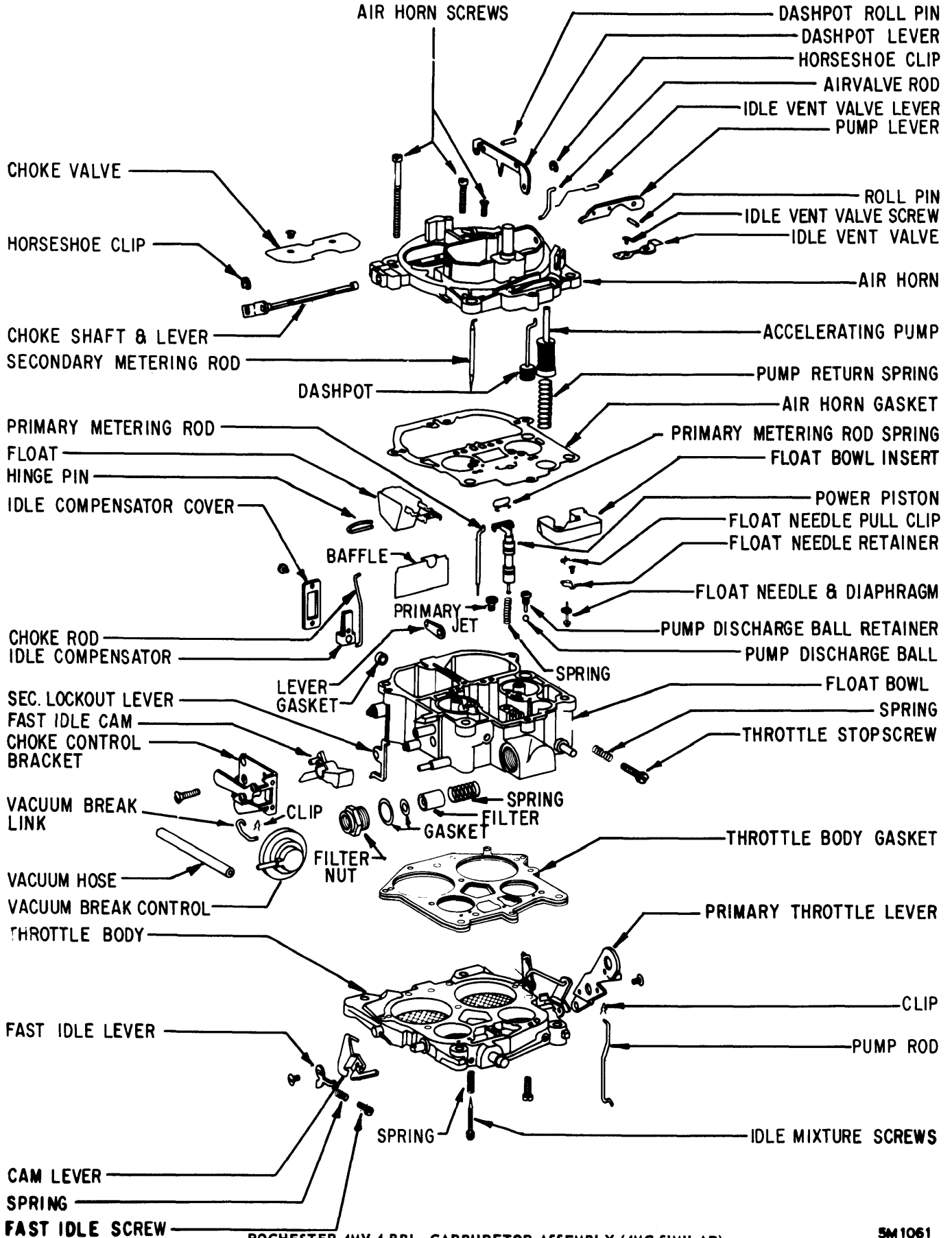

ROCHESTER 4MV 4-BBL. CARBURETOR ASSEMBLY (4MC SIMILAR)

5M1061

## ROCHESTER 4MC &amp; 4MV 4-BARREL (Continued)

and then remove the vacuum break assembly from the lever). On 4MC carburetors, remove the choke coil retaining screws and clips, remove choke cover and coil assembly, remove baffle, take out retaining screw in choke housing assembly and remove assembly from float bowl. On all carburetors, remove fast idle cam from choke assembly. Remove lower choke rod and actuating lever from inside of float bowl well. Remove hot idle compensator cover, then remove hot idle compensator and O-ring from float bowl. Remove fuel inlet filter nut, gasket, filter, and spring. Remove throttle body-to-bowl attaching screws, remove throttle body and insulator gasket.

**Throttle Body** - Remove pump rod from throttle lever by rotating rod out of primary throttle lever. Remove idle mixture screws and springs. **CAUTION** - Be careful not to damage secondary throttle valves. Further disassembly of throttle body is not required.

### Cleaning & Inspection

**CAUTION** - No rubber parts, plastic parts, diaphragms, or pump plungers should be immersed in carburetor cleaner. However, the plastic cam on air valve shaft may be cleaned normally in carburetor cleaner. If air valve or cam are damaged, or air valve is binding, air horn assembly must be replaced. Blow out all passages with compressed air, inspect all parts for wear or damage, replace parts as necessary.

### Reassembly

Reverse disassembly procedure using all new gaskets. When reassembling float bowl, be sure to adjust float level and make all other adjustments. See "Adjustment".

**Air Horn Installation** - To prevent distortion of the air horn and binding of choke valve or air valve, tighten all air horn screws in correct sequence as shown in the illustration.

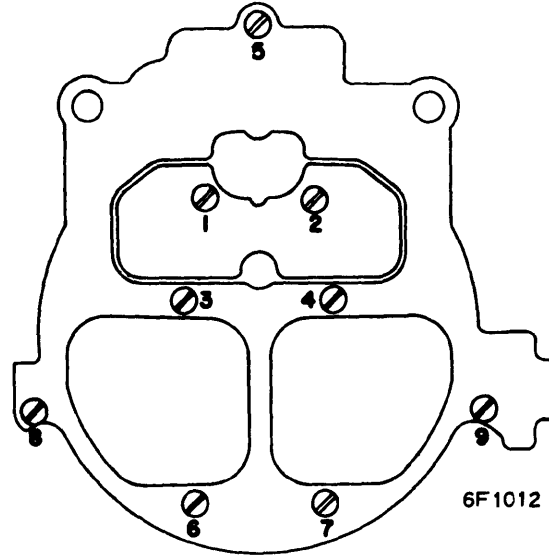

AIR HORN SCREW TIGHTENING SEQUENCE