

ROCHESTER H & HV SINGLE BARREL

1960 MODELS

	Rochester No.
CORVAIR	
All Models (Early).....	H 7015300
Powerglide (Late).....	H 7015310
Powerglide (Limited Production).....	H 7015312
Synchro-mesh (Late).....	H 7015311
Synchro-mesh (Limited Production).....	H 7015313
High Performance Engine.....	H 7015319

1961 MODELS

CORVAIR	
Powerglide (Early).....	H 7019100
Powerglide (Late).....	H 7019110
Synchro-mesh (Early).....	H 7019101
Synchro-mesh (Late).....	H 7019111
High Performance Engine (Early).....	H 7019107
High Performance Engine (Late).....	H 7019117

1962 MODELS

CORVAIR	
Powerglide.....	HV 7020101
Synchro-mesh.....	HV 7020100

1963 MODELS

CORVAIR	
Powerglide.....	HV 7023101
Synchro-mesh.....	HV 7023100
High Performance Engine.....	HV 7023102

1964 MODELS

CORVAIR	
Powerglide.....	HV 7024022
Synchro-mesh.....	HV 7024023
High Performance Engine.....	HV 7024024
Air Conditioned.....	HV 7024025

1965 MODELS

CORVAIR	
95 HP All Trans.	HV 7025023
110 HP Synchro-mesh	HV 7025023
Auto. Trans.	HV 7025024
95 & 110 HP Air Cond.	HV 7025025
140 HP Primary	HV 7025023
Secondary.....	H 7025226

1966 MODELS

CORVAIR	
95 HP Engines (No A.I.R.)	
(Synchro-mesh)	HV 7026023
(Auto. Trans.).....	HV 7026024
95 HP Engines (With A.I.R.)	
(Synchro-mesh).....	HV 7036015
(Auto. Trans.).....	HV 7036014
110 HP Engines (With A.I.R.)	
(Synchro-mesh).....	HV 7036023
(Auto. Trans.).....	HV 7036024
140 HP Engines (No A.I.R.)	
(Synchro-mesh) Primary Carb.....	HV 7026023
Secondary Carb.....	H 7026026
(Auto. Trans.) Primary Carb.....	HV 7036023
Secondary Carb.....	H 7026026
140 HP Engines (With A.I.R.)	
(Synchro-mesh) Primary Carb.....	HV 7036023
Secondary Carb.....	H 7026026
(Auto. Trans.) Primary Carb.....	HV 7026024
Secondary Carb.....	H 7026026

1967 MODELS

CORVAIR	
95 & 110 HP Engines (No A.I.R.)	
(Synchro-mesh).....	HV 7026023
(Auto. Trans.).....	HV 7026024
95 & 110 HP Engines (With A.I.R.)	
(Synchro-mesh).....	HV 7026015
(Auto. Trans.).....	HV 7036014

► CHANGES, CAUTIONS, CORRECTIONS

► **"A.I.R." CARBURETOR NOTE:** These carburetors are used on engines with Air Injection Reactor exhaust emission control system and are special units with different jet calibrations and specifications.

► **1960 CORVAIR LIMITED PRODUCTION CARBURETORS (7015312 & 7015313) NOTE & FLOAT SETTING ADJUSTMENT CAUTION:** These two carburetors with spring loaded needle valve and seat assembly, and with special float (dimple embossed on side of float at toe end), were used in limited production. Float setting on these carburetors is different than for carburetors with solid type needle valves. See "Float Level" below.

► **1960 CORVAIR CARBURETOR FLOAT ASSEMBLY, NEEDLE VALVE & SEAT ASSEMBLY REPLACEMENT NOTE (Carburetors No. 7015312 & 7015313 or Earlier Carburetors with an "A" Stamped on Metal Identification Tag):** It is recommended that needle & seat assembly, Part No. 7015789 and float assembly, Part No. 7015241 (without dimple) be used for service replacement on carburetors No. 7015312 & 7015313. Use float assembly, Part No. 7015241 for service replacement on carburetors No. 7015310 & 7015311 which have letter "A" stamped on Tag.

► **1961 CORVAIR (ALL SERIES) ERRATIC IDLE OR PERIODIC MISS CORRECTION:** If smooth idle is not obtained after correct adjustment of accelerator linkage and carburetor synchronization (with correct fast idle setting of .045"), drill throttle plates as follows: Remove carburetors from engine and drill a 1/16" hole (80 HP Eng.); 3/32" hole (98 HP Eng.) in each throttle plate 1/4" from edge of plate in vicinity of carburetor idle air bleed passage (see illustration below for exact location). *NOTE - It is not necessary to remove throttle plates for drilling.*

► **1961 CORVAIR ENGINE SURGE CORRECTION (CARB. NOS. 7019100 & 7019107):** On Carburetor No. 7019100, install Main Metering Jet, Part No. 7002650 and Venturi Cluster, Part No. 7020344 to replace the original parts. On Carburetor No. 7019107, install Main Metering Jet, Part No. 7002651, Venturi Cluster, Part No. 7020342, Cluster Gasket, Part No. 7020195, and Main Well Insert, Part No. 7009212.

► **1961 CORVAIR FLAT SPOT ON ACCELERATION CORRECTION (CARB. NO. 7019100):** If this condition exists on carburetors with two holes in accelerating pump actuating lever, check to see if pump is on index (scribe mark on accelerating pump shaft lever in line with cast tang on carburetor bowl cover). If pump is on index, proceed as follows to correctly adjust stroke: Disconnect pump rod from inboard hole in lever and connect rod to outboard hole, then bend pump rod to align index mark with cast tang. Reconnect rod in inboard hole. **DO NOT RE-INDEX.**

► **1961-62 CORVAIR ENGINE POOR IDLE & STALLING CORRECTION:** Poor engine idling or stalling immediately after a hot start, or during long idling periods in slow traffic can be corrected as follows: Remove bowl covers from both carburetors, then remove float, float needle and cover gaskets. Invert cover and drill two 3/16" holes as shown

ROCHESTER H & HV SINGLE BARREL (Continued)

in illustration. **NOTE** - Holes must be drilled straight through to break out inside the air horn. Remove chips and burrs and reassemble carburetors. The above procedure will provide additional internal venting.

CARBURETOR IDENTIFICATION

Rochester carburetor number is stamped on tag attached to carburetor. **NOTE** - A.I.R. carburetors have square tag, all other carburetors have triangular tags.

DESCRIPTION

1961-62 Model H Carburetors - Single barrel downdraft type. These carburetors have different choke assemblies as follows:

1960 Models - Single barrel downdraft type without choke assembly, fast idle, or unloader mechanism. The automatic choke, fast idle, and unloader are part of the separate air horn assembly which is centrally located between the two carburetors.

1961 Models - Single barrel downdraft type with manual choke assembly and fast idle.

1965-66 Model H (Secondary) Carburetors - Used with HV carburetors on 140 HP Engines (4 carburetor installation).

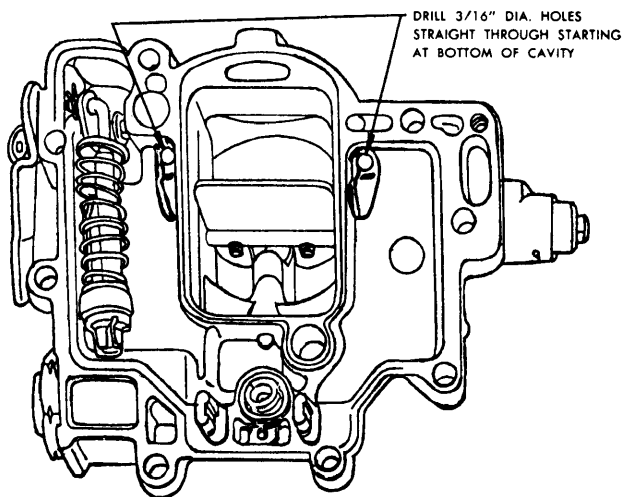

5M1000

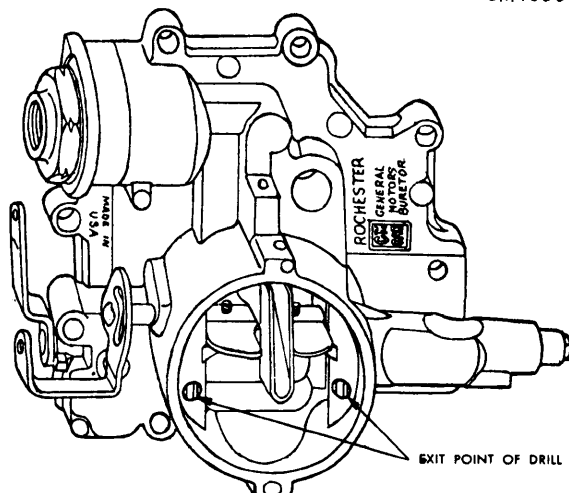

1961-62 CARBURETOR DRILLING LOCATIONS TO CORRECT STALLING

Same design as HV carburetors except that no choke, idle and low speed system, or power enrichment system is used. Late 1965 & 1966 carburetors have lockout linkage to prevent operation during engine warm up (see illustration) which is released by tang on primary carburetor choke shaft. See *Adjustments*.

1962 & Later HV Carburetors - Single barrel downdraft type with separate Well Type automatic choke. Automatic choke consists of a thermostatic coil assembly mounted on lower side of cylinder head and linked directly to carburetor choke valve shaft. A vacuum break diaphragm mounted on carburetor air horn replaces conventional choke vacuum piston. On 1964 and later carburetors, a vapor vent valve is used which is operated by a tang on the throttle shaft lever. On 1965 and later carburetors (except A.I.R.), a power enrichment needle in a passage next to the main well raises as venturi pressure drops in main well to allow additional fuel flow from fuel bowl (not adjustable).

ADJUSTMENT

Final Adjustment

Make all final adjustments with carburetor installed on engine.

Synchronization, Idle Speed & Mixture - See *CARBURETOR on Car Model Pages* for adjustment procedures.

Fast Idle (1960-61 Models) - See *CARBURETOR on Car Model pages*.

Fast Idle (1962-67 Models) - **NOTE** - Make this adjustment after final idle mixture and speed adjustments are completed. Stop engine and place throttle lever on second highest step of fast idle cam. Bend tang on throttle lever to obtain correct clearance between idle speed screw and throttle lever (see "Fast Idle Setting" in Specifications). If clearance not correct, adjust by bending throttle lever tang as necessary. **NOTE** - This adjustment can be made with carburetor off engine by first positioning idle speed screw as follows: With throttle lever in closed position, turn idle speed screw in until firm drag secured on paper strip placed between screw and throttle lever (do not use feeler stock), then turn screw in an additional 1½ turns. With idle speed screw in this position, check fast idle as above.

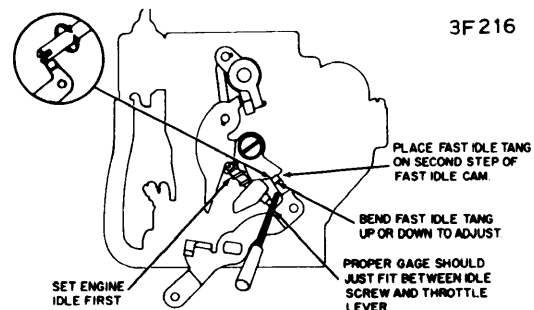

3F216

FAST IDLE ADJUSTMENT

Automatic Choke (1960 Models) - With fast idle cam in slow idle position and with modifier link connected to cross shaft lever, loosen lever and pointer screw and rotate pointer to index mark. **NOTE** - Lever must be pointed toward rear of car. Tighten screw to lock lever and pointer in position.

Automatic Choke (1962-65 Models) - Disconnect choke rod at choke shaft lever. With choke valve held closed, pull control rod up against stop in thermostat bracket and adjust control rod until it freely enters hole in choke shaft lever, then lengthen rod two full turns. **CAUTION** - Turn

ROCHESTER H & HV SINGLE BARREL (Continued)

rod in vertical position. Do not "crank" rod at offset part. Check choke position after engine is at normal operating temperature. Choke valve should be open and fast idle cam should be clear of throttle lever.

Automatic Choke (1966-67 Models) - Disconnect choke rod at choke shaft lever. With choke valve completely closed, pull choke rod upward to limit of travel. Bottom of rod should be even with top of hole in choke valve lever (see illustration). Adjust by turning rod in or out as required. **CAUTION** - Rotate vertical section of rod, do not "crank" rod by turning offset portion,

Vacuum Break Diaphragm (1962-67 Models) - Press diaphragm plunger in until seated, close choke valve to point where connecting link is at end of slot in choke lever (see illustration). Check choke valve opening by inserting gauge of correct size (see Specifications) be-

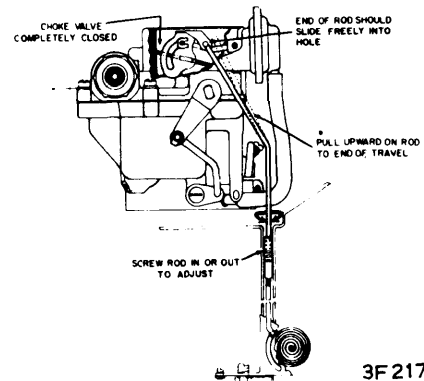

AUTOMATIC CHOKE ADJUSTMENT ("HV" CARBURETORS)

CARBURETOR ADJUSTMENT SPECIFICATIONS								
Rochester Carb. No.	Eng. Idle Speed ^① (Eng. RPM)	Fast Idle Setting	Idle Vent Setting	Float Level Setting	Float Drop Setting	Vacuum Break Setting	Choke Rod Setting	Unloader Setting
7015300	500	1 7/32"	1 3/4"245"
7015310	500	1 7/32"	1 3/4"245"
7015311	500	1 7/32"	1 3/4"245"
7015312	500	1 7/32"	1 3/4"245"
7015313	500	1 7/32"	1 3/4"245"
7015319	800	1 7/32"	1 3/4"245"
7019100	500 ^②	.045"	1 7/32"	1 3/4"
7019101	500 ^②	.045"	1 7/32"	1 3/4"
7019107	^③	.045"	1 7/32"	1 3/4"
7019110	500 ^②	.045"	1 7/32"	1 3/4"
7019111	500 ^②	.045"	1 7/32"	1 3/4"
7019117	^③	.045"	1 7/32"	1 3/4"
7020100	500 ^④	.060"	1 7/32"	1 3/4"	.160"	.160"	.245"
7020101	500 ^④	.050"	1 7/32"	1 3/4"	.160"	.160"	.245"
7023100	500	.050"	1 3/16"	1 3/4"	.160"	.170"	.245"
7023101	500	.065"	1 3/16"	1 3/4"	.160"	.170"	.245"
7023102	600	.050"	1 3/16"	1 3/4"	.160"	.170"	.245"
7024022	500	.075"	.015"	1 1/16"	1 13/16"	.190"	.190"	.325"
7024023	500	.075"	.015"	1 1/16"	1 13/16"	.190"	.190"	.325"
7024024	600	.075"	.015"	1 1/16"	1 13/16"	.190"	.190"	.325"
7024025	600	.075"	.015"	1 1/16"	1 13/16"	.190"	.190"	.325"
7025023	^⑤	.075"	.015"	1 1/16"	1 13/16"	.190"	.190"	.325"
7025024	^⑤	.075"	.015"	1 1/16"	1 13/16"	.190"	.190"	.325"
7025025	^⑤	.075"	.015"	1 1/16"	1 13/16"	.190"	.190"	.325"
7025026	None	None	None	1 1/16"	1 13/16"	None	None	None
7026023	^⑤	.075"	.015"	1 1/16"	1 9/16"	.190"	.190"	.325"
7026024	^⑤	.075"	.015"	1 1/16"	1 9/16"	.190"	.190"	.325"
7026026	None	None	None	1 1/16"	1 9/16"	None	None	None
7036014	^⑥	.075"	.015"	1 1/16"	1 9/16"	.190"	.190"	.325"
7036015	700	.075"	.015"	1 1/16"	1 9/16"	.190"	.190"	.325"
7036023	700	.075"	.015"	1 1/16"	1 9/16"	.190"	.190"	.325"
7036024	600	.075"	.015"	1 1/16"	1 9/16"	.190"	.190"	.325"

① - Automatic Trans. in Drive "D".
 ② - 650 RPM for Air Conditioned Cars.
 ③ - 600 RPM (Synchro-mesh), 500 RPM (Auto. Trans.), 650 RPM (Air Conditioned Cars).
 ④ - 600 RPM for High Perf. Engines, 550 RPM (Air Conditioned Cars).

⑤ - 95 HP 450-500 RPM (Synchro-mesh)
 110 & 140 HP 600-650 RPM (Synchro-mesh)
All Engines (Auto. Trans.) - 500 RPM. Set as low as possible for smooth idling to prevent creep in Drive and harsh shifts in service.
 ⑥ - 500 RPM (95 HP Eng.), 600 RPM (110 HP Eng.).

ROCHESTER H & HV SINGLE BARREL (Continued)

tween lower edge of valve and air horn wall. Adjust by bending connecting link at the angle as shown. **NOTE** - With this adjustment, throttle lever fast idle tang should rest on second step of fast idle cam. See *Choke Rod (Carburetor Off Engine) adjustment*.

Idle Vent (1964-67 Models) - Close throttle valve to point where vent valve just begins to open. At this point, measure throttle valve opening by inserting gauge of correct size (see Specifications) between edge of valve and bore directly opposite idle mixture screw. If throttle opening not correct, adjust by bending tang on throttle lever as required (see illustration). **CAUTION** - Do not bend vent valve spring arm (will cause distortion).

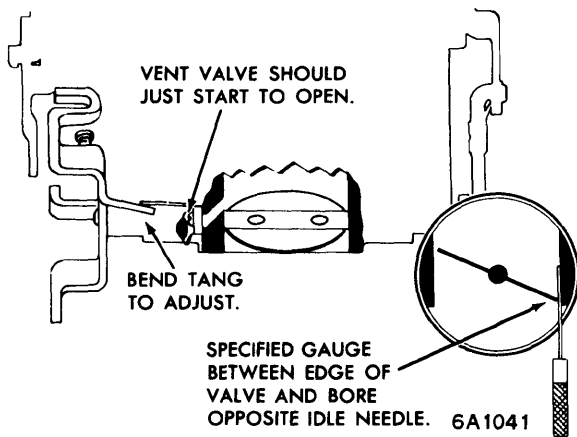

IDLE VENT VALVE ADJUSTMENT

Unloader (1960 Models) - Adjust swivel on fast idle link to obtain $\frac{1}{4}$ " clearance between top of choke valve and wall of air horn with wide open throttle (through detent on automatic transmission cars).

Unloader (1962-67 Models) - Hold throttle valve wide open and measure clearance between lower edge of choke valve and air horn wall using gauge of correct size (see Specifications). Adjust by bending unloader tang on throttle lever.

Pump Rod (1960-61 Models) - Back off idle speed screw until throttle valve is completely closed, then while holding throttle valve closed, check to see that scribe mark on accelerator pump lever is aligned with mark cast into bowl cover. To adjust, bend pump rod at lower end.

Pump Rod (1962-67 Models) - Back out idle speed screw until throttle valve is completely closed, then bend pump rod as necessary to align index mark on upper pump lever with sharp edge of air horn casting. **NOTE** - On automatic transmission cars, make adjustment with rod in outer hole, then reinstall rod in inner hole for proper operation.

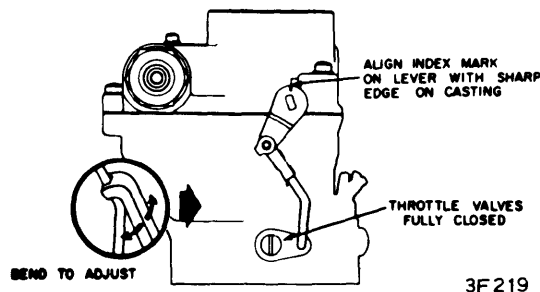

PUMP ROD ADJUSTMENT ("HV" CARBS.)

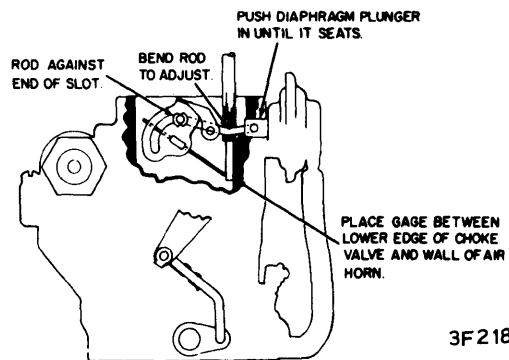

VACUUM BREAK DIAPHRAGM ADJUSTMENT ("HV" CARBS.)

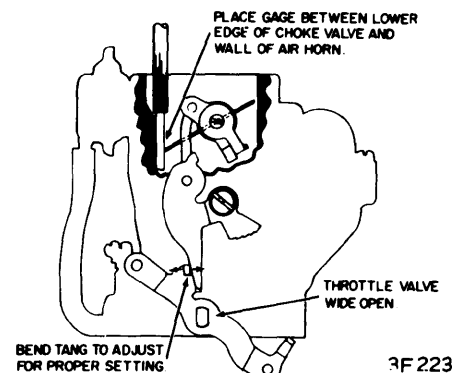

UNLOADER ADJUSTMENT ("HV" CARBS.)

Secondary Carburetor Lockout (1965-66 Model H Carbs.)

NOTE - This secondary carburetor lockout used on late 1965 and all 1966 4-Carburetor installations.

Adjustment - Three separate adjustments required. Adjustment (3) must be made after all carburetors installed on engine.

1) With throttle valve closed and edge of throttle lever lockout tang flush with lockout lever (see illustration), bend throttle lever tang as required for clearance of .020" between throttle lever tang and notch in lockout lever.

(Continued)

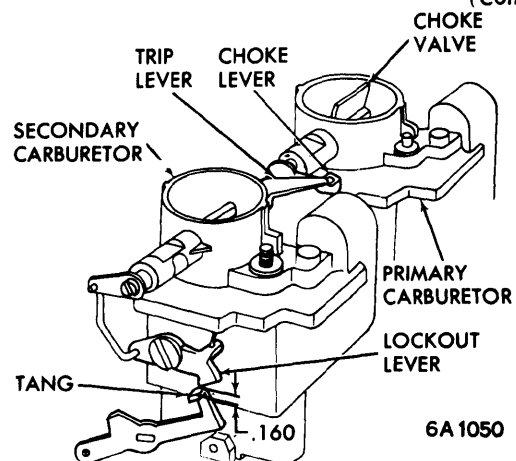

1965-66 PRIMARY & SECONDARY CARBURETOR LOCKOUT LINKAGE ADJUSTMENT

ROCHESTER H & HV SINGLE BARREL (Continued)

- 2) With throttle lever in locked out position, bend stop tang on lockout lever as required for clearance of .060" between stop tang and bottom surface of air horn (see illustration).
- 3) Make certain that choke valve on mating primary carburetor is in full open position, insert a .160" gauge (Tool Set J-9789) between secondary carburetor lockout lever and lockout tang on throttle lever, bend secondary carburetor trip lever to just contact primary carburetor choke lever. Adjust both secondary carburetors in same manner.

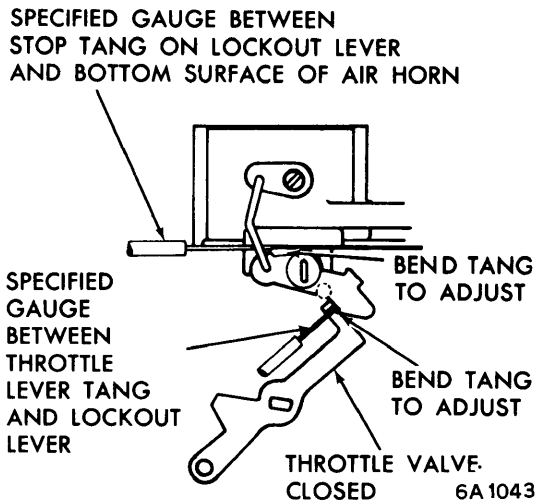

1965-66 SECONDARY CARBURETOR LOCKOUT (MODEL H SECONDARY CARBURETORS)

Initial Adjustment Carburetor Off Engine

- **1960 CORVAIR FLOAT LEVEL ADJUSTMENT NOTE:** Spring loaded needle valve and seat assemblies were used in limited production on Carburetors No. 7015012 & 7015013 in conjunction with a new float assembly identified by a dimple embossed on side of float at toe end. Adjustment

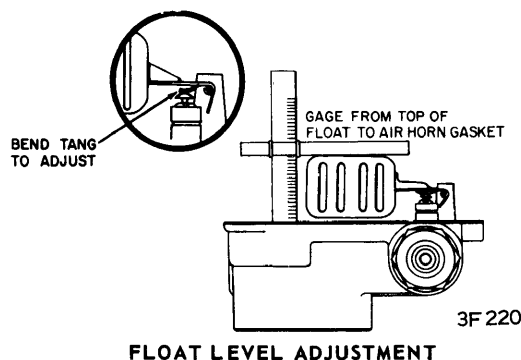

FLOAT LEVEL ADJUSTMENT

specifications and procedures are different than for solid type needle and seat assemblies.

Float Level (1960 Models with Spring Loaded Needle Valve)-With bowl cover inverted, gasket in place, distance from gasket surface to "dimple" on side of float at "toe" end should be 7/16". To adjust, bend float tang.

Float Level (1962-67 Models) - With gasket in place and air horn inverted so that weight of floats is holding needle valve closed, measure from gasket surface to bottom of each float (see illustration). If float setting not correct (see Specifications), adjust by bending float lever tang which contacts inlet needle. Top of floats should be parallel with air horn surface. **NOTE** - Floats should be aligned to prevent interference with sides of bowl when assembly installed.

Float Drop (All Models) - With air horn assembly upright and floats hanging free, measure from gasket surface to bottom of each float (see illustration). If this distance not correct (see Specifications), adjust by bending tang at rear of float arm.

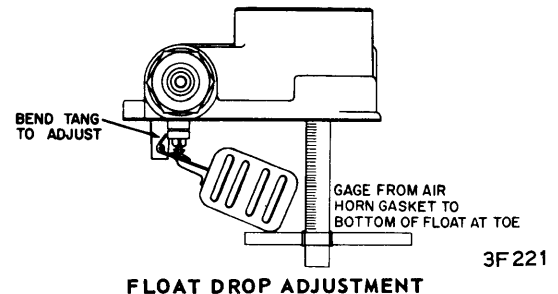

FLOAT DROP ADJUSTMENT

Choke Rod (1962-67 Models) - With fast idle tang on second step of fast idle cam next to highest step, close choke valve so trip lever on choke shaft lever just contacts choke tang on plastic lever and collar assembly. Clearance between lower edge of choke valve and inner wall of air horn should be as shown in Specifications. Adjust by bending tang on trip lever up or down as required (see illustration).

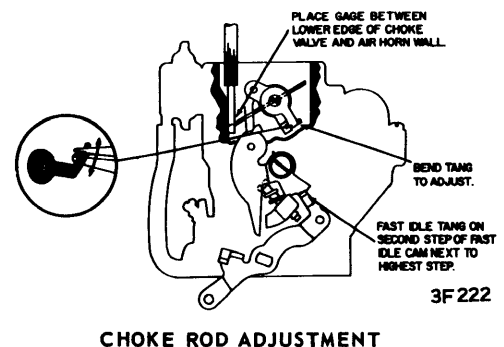

CHOKE ROD ADJUSTMENT

OVERHAUL

Disassembly

- 1) On 1960-61 Models, disconnect pump rod from pump lever, then remove fuel inlet nut, gasket, filter element, and spring. Remove bowl cover and gasket, noting location of the two longer screws on either side of accelerating pump.

- 2) On 1962-67 models, disconnect accelerating pump rod from pump lever, then remove filter element and spring. Remove choke trip lever attaching screw and remove levers from choke shaft. Remove vacuum diaphragm assembly by rotating the assembly to align notch and free it from link. Separate air horn from main body. (Continued)

Rochester Carburetors

ROCHESTER H & HV SINGLE BARREL (Continued)

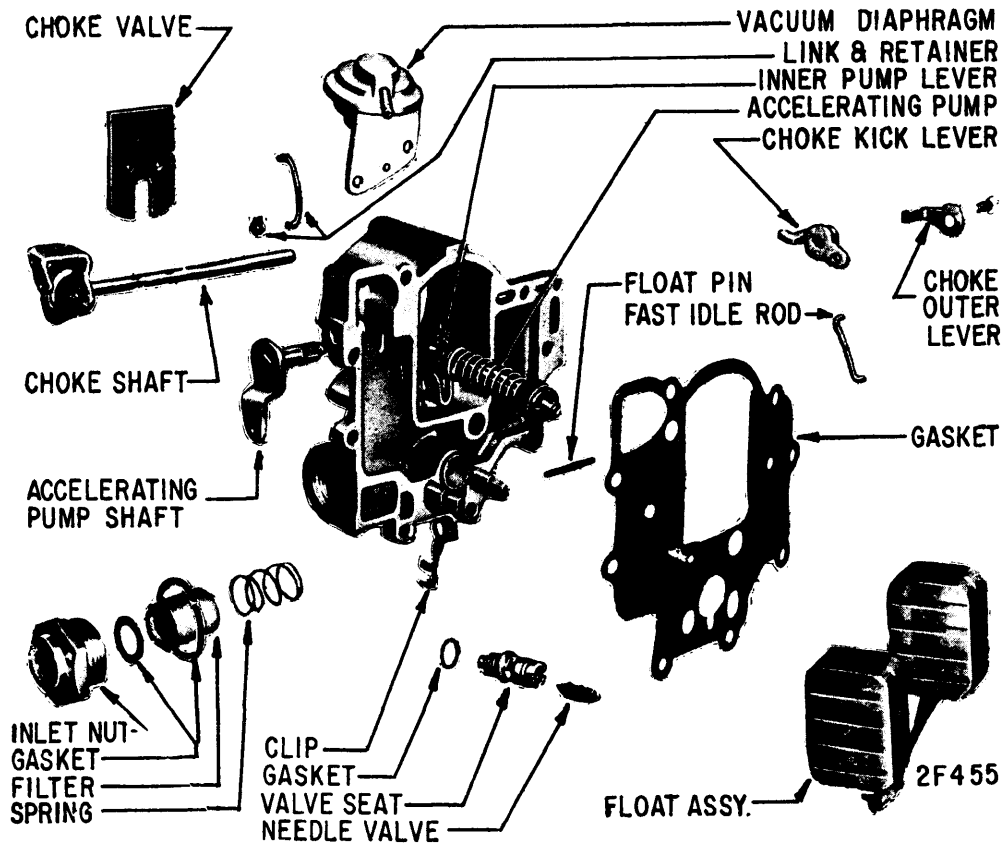

ROCHESTER MODEL HV CARBURETOR AIR HORN ASSEMBLY

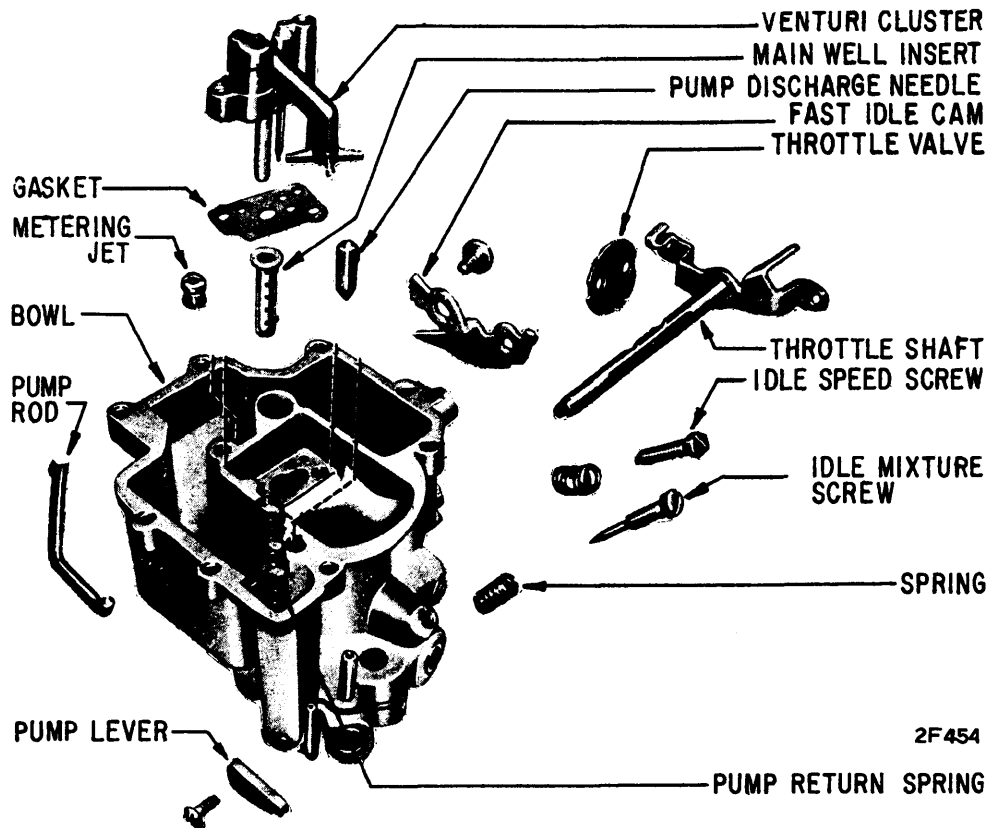

ROCHESTER MODEL HV CARBURETOR BOWL ASSEMBLY

ROCHESTER H & HV SINGLE BARREL (Continued)

3) On all models, remove float assembly and float needle valve. Remove clip from accelerating pump and remove pump, then remove clip, shaft and lever. Remove screws from venturi cluster and remove cluster, gasket, and main well insert. Remove pump discharge valve, power enrichment valve (1965 and later carburetors), idle mixture screw and main metering jet. On 1965 and later carburetors, remove idle vent assembly. If necessary, remove choke valve retaining screws and remove choke valve and shaft.

4) On 1961 Models, remove fast idle cam attaching screw, spring and throttle kick lever. On 1962 and later models, remove fast idle cam. On all models, if necessary, remove throttle valve retaining screws, valve and shaft.

Cleaning & Inspection

Clean carburetor castings and all metal parts in cleaning solution. *Do not immerse pump plunger, gasket, or vacuum break assembly in cleaning solution.* Dry parts with air and blow out all passages and jets with air. Inspect all parts for wear or damage and replace as necessary.

Reassembly

Use new gaskets and reassemble carburetor by reversing disassembly procedure. Note the following:

Choke & Throttle Valve Installation - Carefully center and seat valve in shaft and bore before tightening attaching screws. Check assembly for free movement and make certain valve and shaft do not bind.