

1968-74 GENERAL MOTORS CONTROLLED COMBUSTION SYSTEM

DESCRIPTION & OPERATION

The Controlled Combustion System uses three different controls to regulate ignition timing for optimum emission control.

1) Transmission Controlled Spark with Exhaust Gas Recirculation (TCS/EGR) – Used on all V-8 engines with manual transmission and some V-8 engines with automatic transmission.

2) Combined Emission Control with Exhaust Gas Recirculation (CEC/EGR) – Used on all 6 cylinder engines with manual transmission and all Calif. Vega models with manual transmission and non-Calif. Vegas with 2-Bbl. and manual transmission.

3) Ported Vacuum Advance with Exhaust Gas Recirculation (PVA/EGR) – Used on all 6 cylinder engines with automatic transmission.

Function of all three systems is to eliminate distributor vacuum advance when driving in low speeds. Although component usage varies between vehicles, their operation is basically the same. Distributor vacuum advance is governed by a distributor vacuum solenoid or CEC solenoid. On ported vacuum advance applications, a ported vacuum line directly from carburetor to vacuum advance unit allows retarded vacuum advance at idle or closed throttle.

NOTE – Each system is tied together (electrically or by vacuum) with an EGR system. For more information on EGR system see "General Motors Exhaust Gas Recirculation System" in this Section.

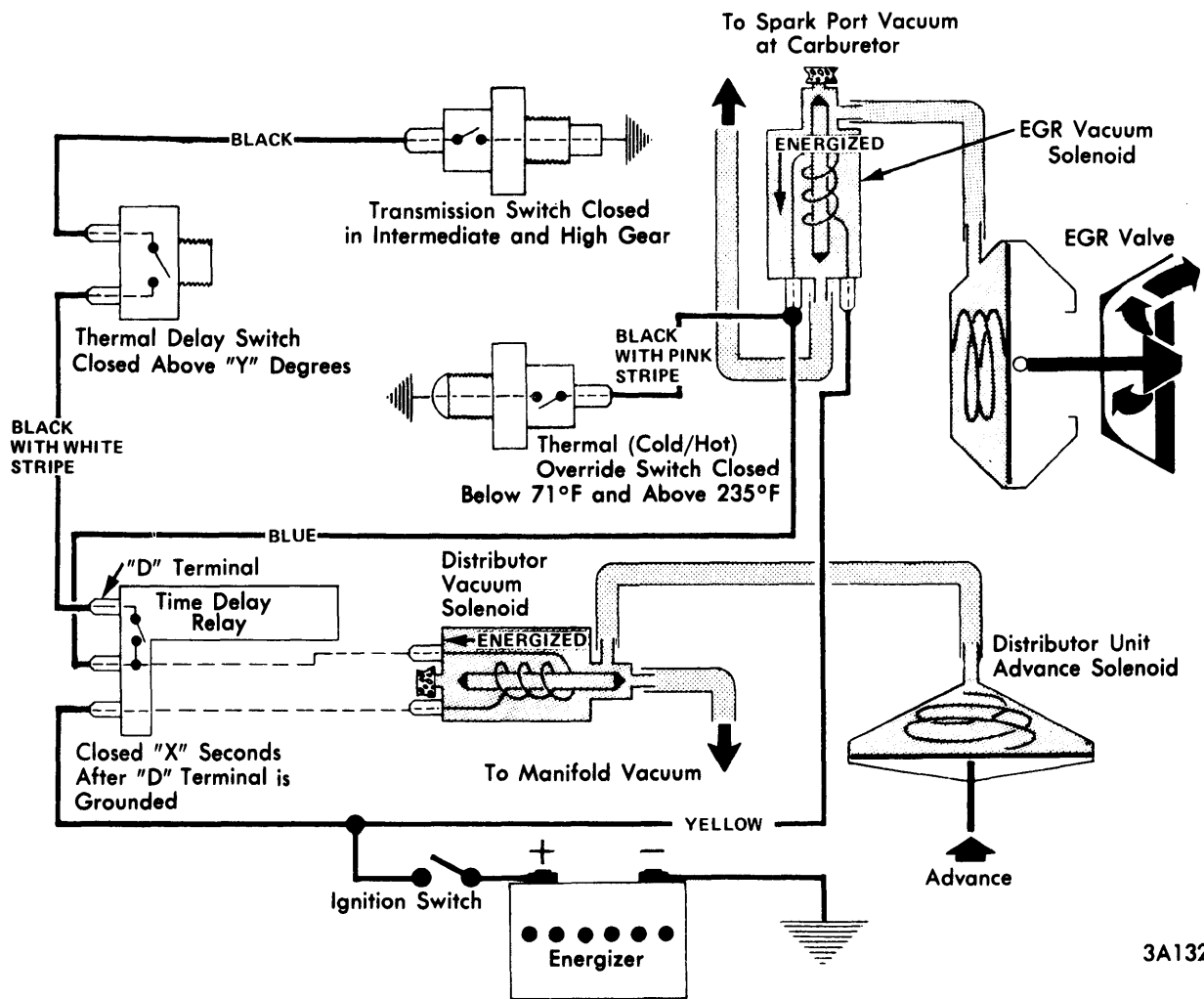

3A132

Y	
DEGREES	COLOR CODE
125°	BLACK
140°	GREY
155°	GREEN

X	
SECONDS DELAY	COLOR CODE
30	WHITE
50	BLUE

TCS/EGR SYSTEM COMPONENTS (TYPICAL)

Exhaust Emission Systems

1968-74 GENERAL MOTORS CONTROLLED COMBUSTION SYSTEM (Cont.)

TCS/EGR - When ignition is "ON", voltage is supplied through time delay relay switch to distributor vacuum solenoid and to one terminal of EGR solenoid. Both solenoids are now ready to receive ground signal. Signal is provided either by thermal override switch or transmission (controlled spark) switch. If signal is from transmission switch, time delay relay waits 33-55 seconds (depending on engine) to complete circuit to both solenoids. This provides full vacuum advance and no EGR. On typical cold start (coolant temperature below 71°F and cylinder head temperature below 125°F), thermal override switch grounds both solenoids, resulting in no EGR and full vacuum advance. When coolant temperature reaches 71°F, thermal override switch de-energizes both solenoids, resulting in full EGR and no vacuum advance. Both solenoids remain de-energized until cylinder head temperature reaches 125°F. Thermal delay switch then grounds, completing circuit between transmission switch and time delay relay. Both solenoids become energized 33-55 seconds (depending on engine) after transmission shifts into second gear or intermediate gear range, resulting in no EGR and normal vacuum advance. When coolant temperature reaches 235°F (hot idle), thermal override switch energizes both solenoids, resulting in no EGR and full vacuum advance for maximum cooling.

NOTE - Manual transmission cars use ported spark vacuum source rather than full vacuum source; therefore, when system allows for vacuum spark advance, it is cut off at closed throttle. All other features of automatic transmission are retained.

CEC/EGR - When ignition is "ON" idle stop solenoid energizes, extending plunger to contact throttle lever. This maintains wider throttle settings at idle to compensate for retarded spark condition produced by this system. Ignition circuit is completed (grounded) through CEC solenoid and cold terminal of temperature switch. At the same time, circuit from ignition switch through time relay coil to ground is completed. With either one or both circuits complete, CEC solenoid is energized, permitting vacuum advance and controlled deceleration by idle stop solenoid. In low gear, after 20 seconds (with engine temperature above 93°F) both time relay and thermostatic coolant temperature switches are open. CEC solenoid is de-energized, vacuum advance is blocked (vented to atmosphere preventing distributor from locking in advance position) and throttle is controlled by idle stop solenoid. With transmission in high gear, transmission switch is closed, grounding circuit from ignition switch. Vacuum advance is restored and CEC solenoid plunger extends, contacting throttle

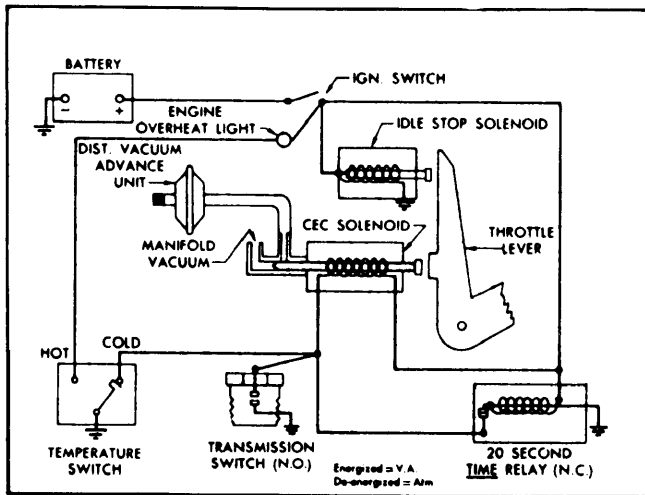

3A133 (ENGINE OFF)

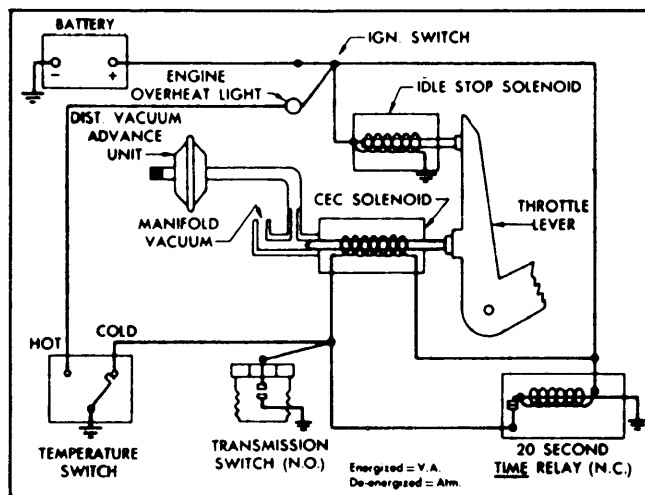

(COLD OVERRIDE AND TIME RELAY ENERGIZED)

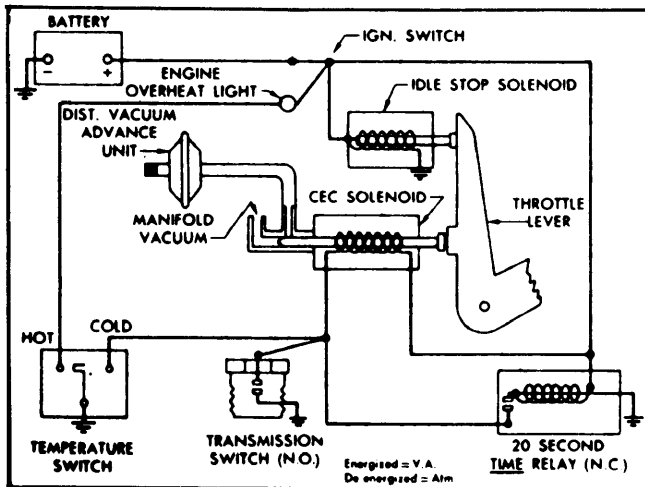

(LOW GEAR OPERATION)

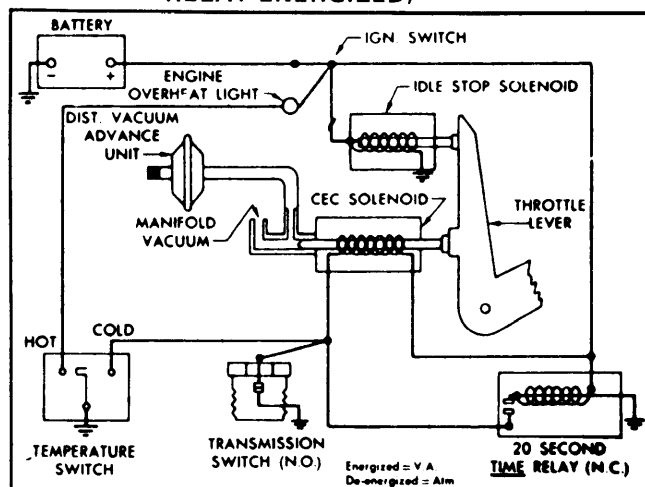

(HIGH GEAR OPERATION)

CEC/EGR SYSTEM COMPONENTS (TYPICAL)

1968-74 GENERAL MOTORS CONTROLLED COMBUSTION SYSTEM (Cont.)

lever to provide deceleration control at a preset value. When ignition is turned "OFF", idle stop solenoid allows throttle valve to close beyond idle, preventing engine dieseling. EGR system vacuum actuated valve controls exhaust gases into intake manifold and is regulated by spark port vacuum signal. At idle there is no EGR. At speed, EGR will be present, depending on throttle opening.

PVA/EGR – This system has a direct vacuum line between ported vacuum carburetor port and distributor vacuum advance. A tee fitting connects EGR valve to the same line (EGR valve also uses ported vacuum signal from carburetor). The direct line allows retarded vacuum advance at idle, or closed throttle and full vacuum advance at all other times.

Temperature Switch – Mounted on left side of block (most 6 cylinder and V-8 engines) this three-position switch has a double terminal unit with a neutral position. At coolant temperatures below 93°F, the cold terminal is grounded, completing circuit to vacuum advance solenoid. In neutral position no contact is made (circuit broken). When engine starts to overheat, the hot terminal is grounded, and "hot" light in instrument panel is activated.

Thermal Vacuum Switch – Used on some V-8 engines to advance ignition timing at idle when high (226°F) coolant temperature is reached. When activated, internal valve moves, directing vacuum advance to distributor. Some 2-Bbl. applications use vacuum reducer in line to distributor, and some 4-Bbl. applications use thermal check and delay valve between thermal vacuum switch and carburetor. Ignition timing is then advanced allowing engine to run cooler.

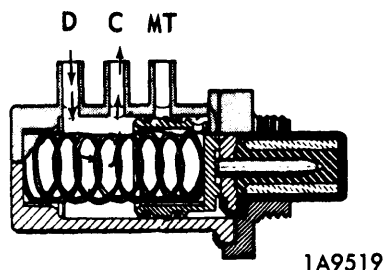

D – To Distributor Vacuum Advance
 C – To Carburetor
 MT – To Intake Manifold

THERMO VACUUM VALVE (TYPICAL)

Thermal Check and Delay Valve – Used on some 4-Bbl. applications in conjunction with thermal vacuum switch. Located in vacuum hose between carburetor ported spark port and thermal vacuum switch center port ("C"). Below 50°F (underhood air temperature) valve is in restricting position. Vacuum is metered through .005" orifice in valve. Full vacuum advance takes up to 40 seconds to occur after distributor ported vacuum drops to zero. In restricting position, pressure differential in valve causes valve to momentarily open equalizing vacuum between vacuum advance and distributor, thereby retarding vacuum advance. Above 226°F (coolant temperature) valve is by-passed when thermal vacuum switch directs vacuum to distributor. Vacuum for advance comes from intake manifold.

Vacuum Reducer Valve – Used on some 2-Bbl. applications in conjunction with thermal vacuum switch. Located in line between intake manifold elbow and lower port ("MT") of thermal vacuum switch. Valve reduces manifold vacuum 3" below advance vacuum, preventing detonation when coolant temperature is above 226°F and thermal vacuum switch "MT" port is open to distributor advance. Reducer valve has one port on manifold elbow side and two on thermal vacuum switch side. Reducer valve center port is open to vent at carburetor air horn. Other port connects to "MT" port of thermal vacuum switch.

Distributor Vacuum Advance Solenoid – Used on V-8 engines, this electrically operated two-position plunger controlled valve serves to supply or deny vacuum to distributor vacuum advance unit. When energized, the plunger opens vacuum port from carburetor while simultaneously closing air vent (fresh air) port allowing normal vacuum advance. When de-energized, the spring loaded plunger seats against vacuum inlet and opens distributor advance unit to fresh air vent.

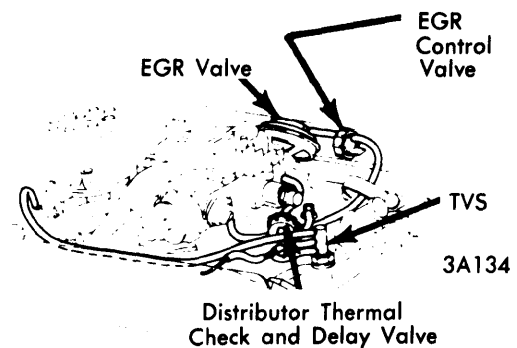

VACUUM HOSE ROUTING – TYPICAL 4-BBL.

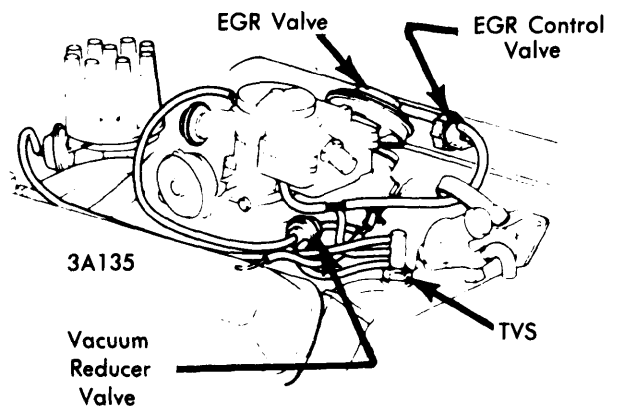

VACUUM HOSE ROUTING – TYPICAL 2-BBL.

TESTING

TCS System – At distributor vacuum and time delay solenoid, remove hose to distributor. Hook vacuum gauge to bared fitting and place gauge so it can be observed from drivers seat. Run engine until thoroughly warm (about 10 minutes at room temperature). With transmission in "N" depress throttle

Exhaust Emission Systems

1968-74 GENERAL MOTORS CONTROLLED COMBUSTION SYSTEM (Cont.)

slightly to uncover spark port. Vacuum should be present. With throttle still depressed, shift transmission into first gear. No vacuum should be present. If vacuum reading is constant at all times (caused by closed circuit), check for grounded wire in circuit, thermal override switch stuck closed (activated) or transmission switch stuck closed. If no vacuum was present during test (caused by open circuit), check for blockage in vacuum lines, carburetor fitting or carburetor. Also check for blown radio fuse, broken wire in system, thermal delay switch stuck open, solenoid coil wire broken or open, or defective time relay switch. Check all hoses for proper routing and good connections.

NOTE — This test will also diagnose CEC system and vacuum check PVA system.

ADJUSTMENT

CEC Valve Adjustment — Adjustment is to be made only after replacement of solenoid, major carburetor overhaul or after throttle body is removed and replaced. **NOTE** — CEC Valve setting is made only after completing instructions on tune-up sticker. With engine running and transmission in "N" (manual transmission) or in "D" (automatic transmission), air conditioning OFF, distributor vacuum hose disconnected and plugged, and fuel tank hose from vapor canister disconnected, manually extend CEC valve plunger to contact throttle lever. Then adjust plunger length to specified idle speed.

Transmission Switch — On manual transmission with double terminal switch (in engine compartment), disconnect wire from switch and ground one of the terminals. Connect a test lamp to

the other terminal and to a 12-volt source. Loosen adjusting screws and position switch so that test lamp will be OFF when transmission is in high gear and ON in all lower gears.

MAINTENANCE

No maintenance is required of any component in the system. If any component is not functioning properly, it should be replaced.

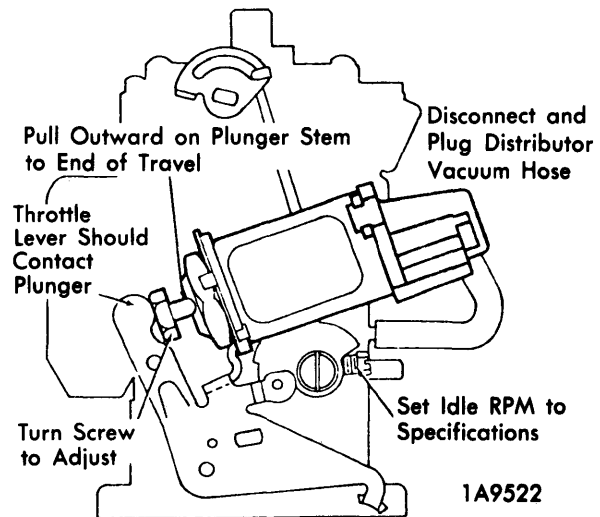

CEC VALVE ADJUSTMENT (TYPICAL)