

1974 FORD MOTOR CO. VACUUM DIAGRAMS

To find correct vacuum diagram usage, refer to engine identification label (not colored exhaust emission decal). Label is located at rear of left rocker cover on V6 or V8 engines or left side rear on four and six cylinder engines. Determine calibration and revision (see illustration). Using following table; match model, engine, transmission, calibration and revision level to determine illustration number of vacuum diagram to be used.

tion and revision (see illustration). Using following table; match model, engine, transmission, calibration and revision level to determine illustration number of vacuum diagram to be used.

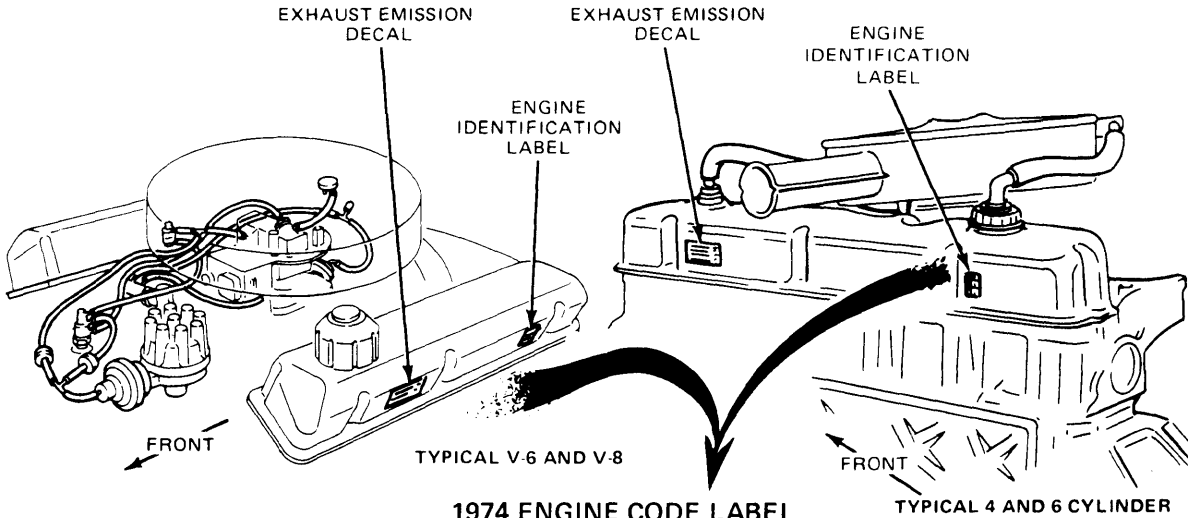

1974 ENGINE CODE LABEL IDENTIFICATION CHART

POS. 1 (YR.)	50 STATE	49 STATE	CALIFORNIA CODING)
0	0	A	L
1	1	B	M
2	2	C	N
3	3	D	P
4	4	E	R
5	5	F	S
6	6	G	T
7	7	H	U
8	8	J	W
9	9	K	X

- A - AIR-CONDITIONING
- B - NON AIR-CONDITIONING
- C - INDUSTRIAL & MARINE
- D - EXPORT
- E - OVER 6000 LBS.
- F - THERMACTOR WITHOUT A/C
- G - A/C OR NON A/C ENGINES
- H - POWER STEERING
- J - THERMACTOR WITH A/C
- K - THERMACTOR A/C OR NON A/C

BASE
(DISPLACEMENT)
(VEHICLE APPLICATION)
(INERTIA WEIGHT)
(AXLE RATIO)
(TRANSMISSION)

DESIGN LEVEL L - USED TO INDICATE INITIAL RELEASE FOR 1974

CALIB & REVISION LEVEL (ZERO) O - USED TO INDICATE INITIAL RELEASE FOR 1974

(OPTIONAL) DENOTES CARB & DIST USED ON ENGINE

CALIBRATION NUMBER
REVISION LEVEL



DENOTES PLANT SOURCED TO PRODUCE ENGINES

- D - DEARBORN ENGINE PLANT
- L - LIMA ENGINE PLANT
- C1 - CLEVELAND ENGINE PLT 1
- C2 - CLEVELAND ENGINE PLT 2
- W1 - WINDSOR ENGINE PLT 1
- W2 - WINDSOR ENGINE PLT 2

INITIAL TIMING (OPTIONAL)

RPM SETTING (OPTIONAL)

SERVICE LEVEL (CONTROLLED BY INDIVIDUAL PLANTS)

4FOE44

1974 ENGINE CODE LABEL

Exhaust Emission Systems

VACUUM SYSTEM DIAGRAMS				
Vehicle	Transmission	Calibration	Revision	Illus. No.
2000 cc 2-Bbl. Pinto — All Models Pinto — All Models Pinto — Sedan	Man. Trans. Man. Trans. Auto. Trans.	4-2A 4-2B 4-2D	R0 R0 R4	4FOE1 4FOE2 4FOE3
2300 cc 2-Bbl. Pinto — All Models — Mustang Pinto — All Models — Mustang	Auto. Trans. Man. Trans.	4-1T 4-1U	R1 R1	4FOE4, 5 4FOE6, 7
2800 cc 2-Bbl. Mustang Mustang Mustang Mustang	Auto. Trans. Man. Trans. Auto. Trans. Man. Trans.	4-4A 4-4D 4-4U 4-4V	R16 R11 R11 R3	4FOE8 4FOE9 4FOE10 4FOE8,11
200" 1-Bbl. Maverick, Comet Maverick, Comet Maverick, Comet Maverick	Man. Trans. Auto. Trans. Auto. Trans. Auto. Trans.	4-6A 4-7A 4-7B 4-7T	R2 R0 R2 R11	4FOE12, 13 4FOE14, 15 4FOE16, 17 4FOE18, 19
250" 1-Bbl. Maverick, Comet Maverick, Comet Maverick Maverick, Comet	Man. Trans. Auto. Trans. Auto. Trans. Man. Trans.	4-8C 4-9 4-9D 4-9U	R3 R3 R3 R5	4FOE16, 17 4FOE20, 21 4FOE22, 23 4FOE22, 23
302" 2-Bbl. Maverick, Comet Ranchero Torino, Montego Maverick, Comet Ranchero Maverick, Comet Torino, Torino S.W., Montego Torino S.W., Montego S.W.	Man. Trans. Man. Trans. Man. Trans. Auto. Trans. Auto. Trans. Auto. Trans. Auto. Trans. Auto. Trans.	4-10A 4-10C 4-10D 4-11A 4-11C 4-11D 4-11E 4-11F	R0 R0 R3 R0 R0 R0 R4 R3	4FOE24 4FOE25, 26 4FOE27, 28 4FOE29 4FOE30, 31 4FOE30 4FOE29, 32 4FOE33
351" 2-Bbl. (W) Torino, Montego, Cougar, Ford Montego 4 Dr. P.H.T., Ford H.T., Ford S.W. Torino, Montego, Cougar, Ford Montego 4 Dr. P.H.T., Ford H.T., Ford S.W.	Auto. Trans. Auto. Trans. Auto. Trans. Auto. Trans.	4-12 4-12B 4-12D 4-12E	R0 R0, R3 R0 R0	4FOE34, 35 4FOE34, 35 4FOE34, 35 4FOE34, 35
351" 2-Bbl. (C) Torino, Montego, Cougar, Ranchero, Ford S.W., Ford, Mercury Sedan Torino, Montego Sedan & S.W. Torino, Montego, Ranchero, Cougar, Ford, Mercury, Ford S.W.	Auto. Trans. Auto. Trans. Auto. Trans.	4-14E 4-14E 4-14N	R12 R13 R13, R15	4FOE36 4FOE36, 37 4FOE36, 37
400" 2-Bbl. Ford, Mercury S.W. Ford, Mercury Torino, Montego, Ranchero, Ford, Mercury Ford, Mercury S.W. Torino, Montego, Ranchero, Cougar	Auto. Trans. Auto. Trans. Auto. Trans. Auto. Trans. Auto. Trans.	4-17 4-17 4-17 4-17T 4-17T	R25 R29 R29 R13 R13	4FOE35 4FOE32 4FOE38 4FOE40 4FOE39
460" 4-Bbl. Ford, Montego S.W., Mercury Sedan & S.W., Thunderbird, Mark IV, Lincoln Torino, Montego, Cougar, Torino S.W., Ford, Mercury Ford, Mercury, Torino, Montego Torino, Montego, Cougar, Torino S.W., Ford, Mercury Ranchero Ranchero Torino, Torino S.W., Montego, Cougar, Ford, Mercury Torino, Montego S.W., Ford, Mercury Sedan & S.W., Lincoln, Mark IV, Thunderbird	Auto. Trans. Auto. Trans. Auto. Trans. Auto. Trans. Auto. Trans. Auto. Trans. Auto. Trans. Auto. Trans.	4-19 4-19B 4-19C 4-19E 4-19F 4-19R 4-19T 4-19T	R9 R3 R3 R7 R1 R1 R1 R8	4FOE41 4FOE41 4FOE42 4FOE41 4FOE41 4FOE43 4FOE43 4FOE43

Exhaust Emission Systems

1974 FORD MOTOR CO. VACUUM DIAGRAMS (Cont.)

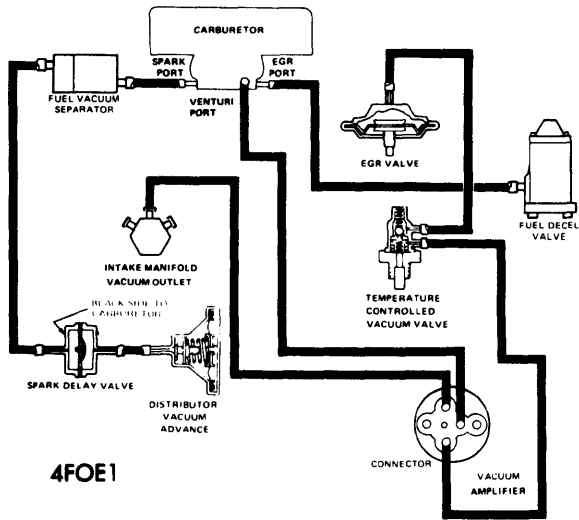

4FOE1

PINTO SEDAN & S.W. NON A/C

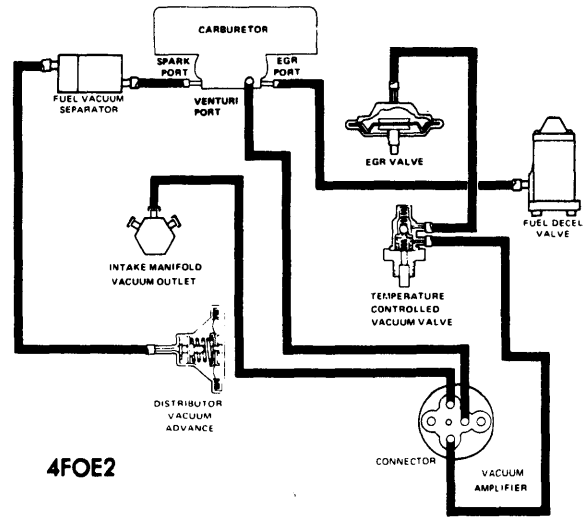

4FOE2

PINTO SEDAN & S.W. NON A/C

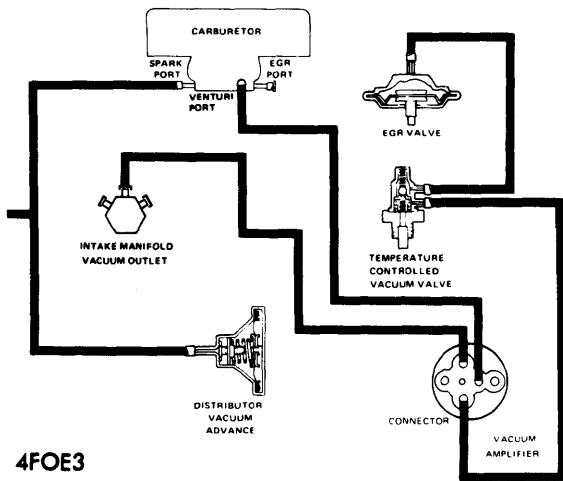

4FOE3

PINTO SEDAN A/C

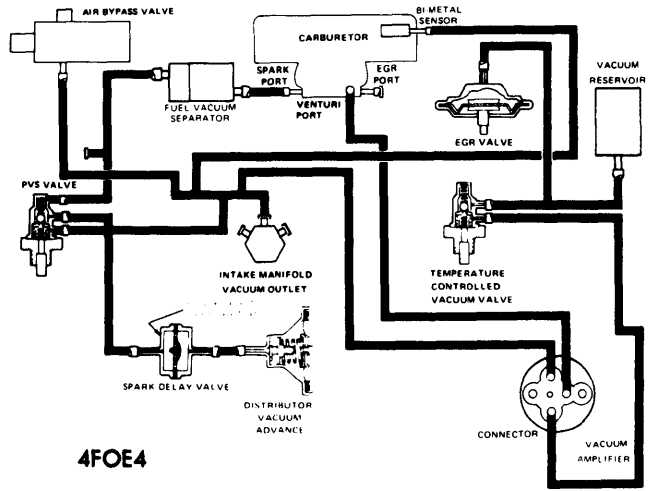

4FOE4

PINTO SEDAN & S.W., MUSTANG A/C

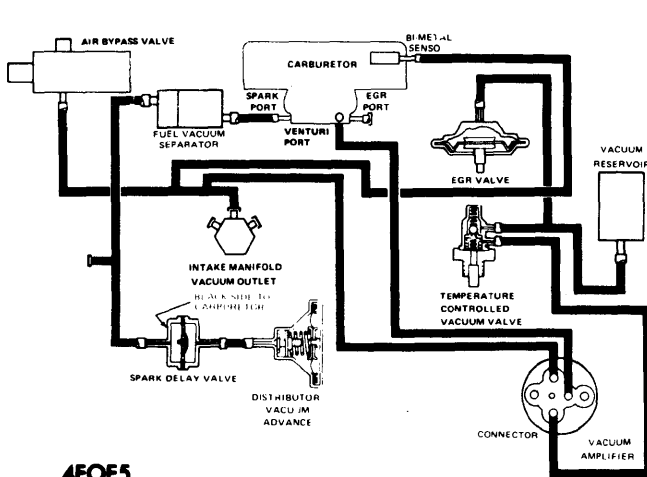

4FOE5

PINTO SEDAN & S.W., MUSTANG NON A/C

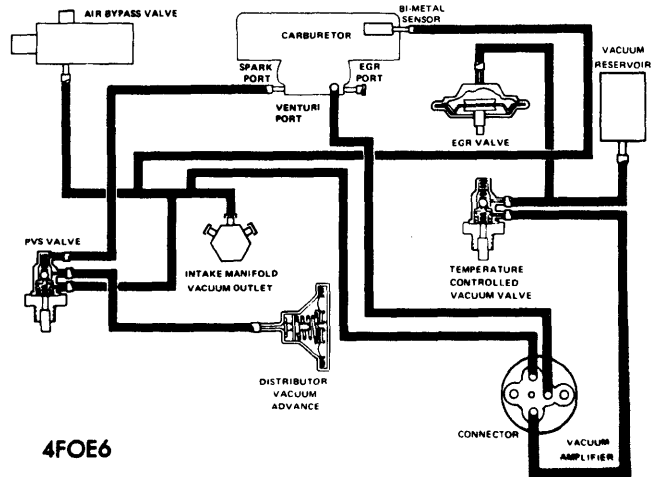

4FOE6

PINTO SEDAN & S.W., MUSTANG A/C

Exhaust Emission Systems

1974 FORD MOTOR CO. VACUUM DIAGRAMS (Cont.)

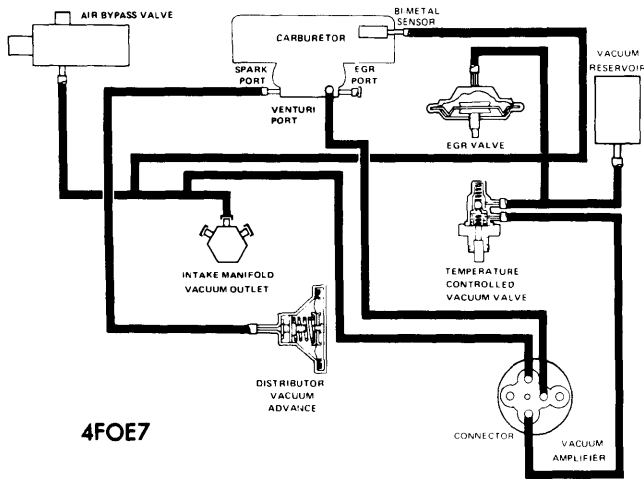

4FOE7

PINTO SEDAN & S.W., MUSTANG NON A/C

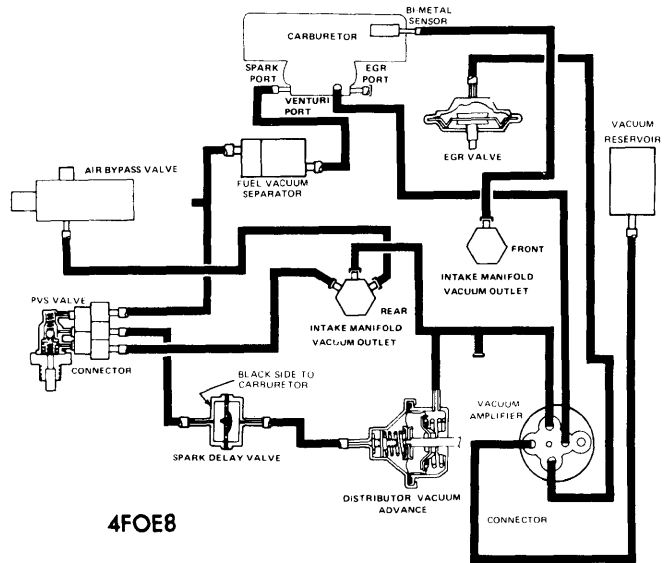

4FOE8

MUSTANG

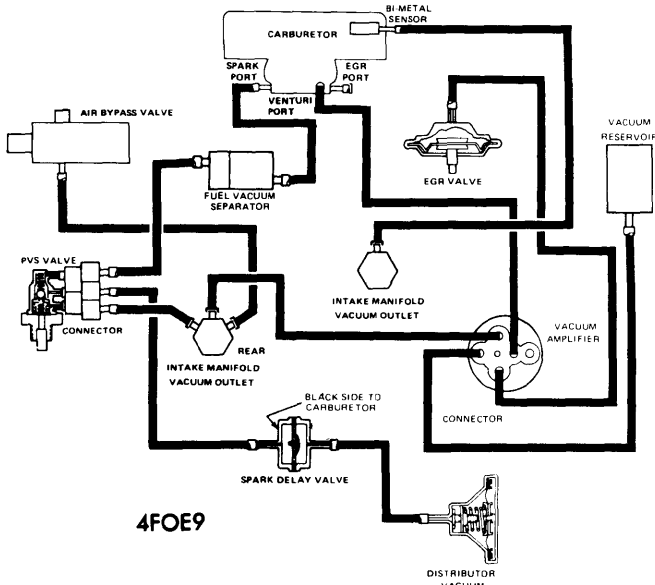

4FOE9

MUSTANG

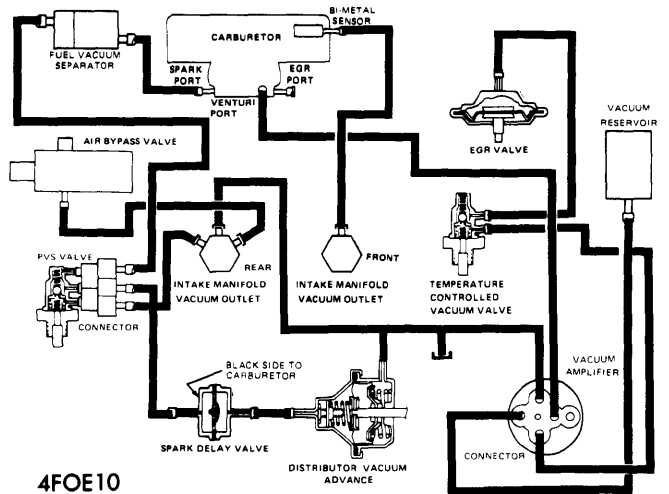

4FOE10

MUSTANG

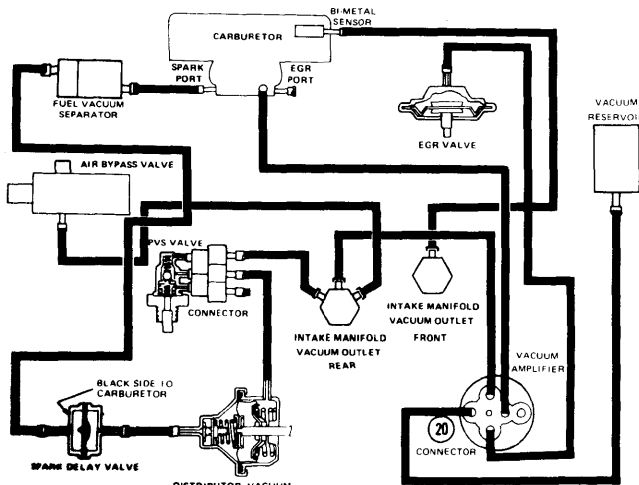

4FOE11

MUSTANG NON A/C

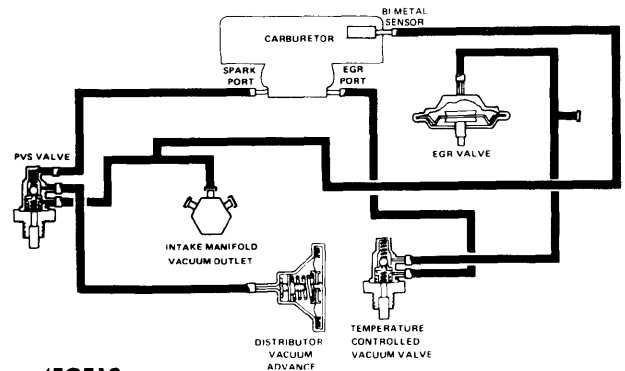

4FOE12

MAVERICK & COMET A/C

Exhaust Emission Systems

1974 FORD MOTOR CO. VACUUM DIAGRAMS (Cont.)

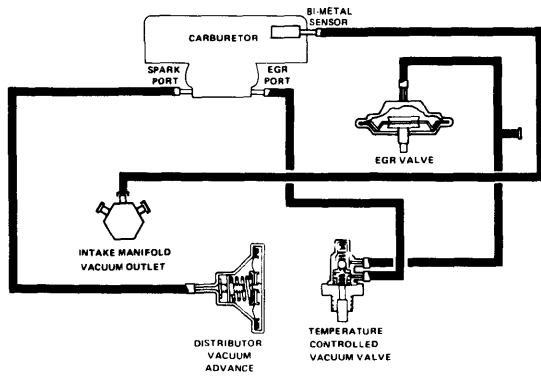

4FOE13

MAVERICK & COMET NON A/C

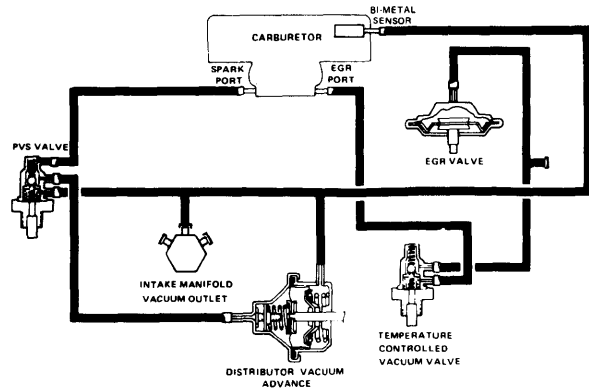

4FOE14

MAVERICK & COMET A/C

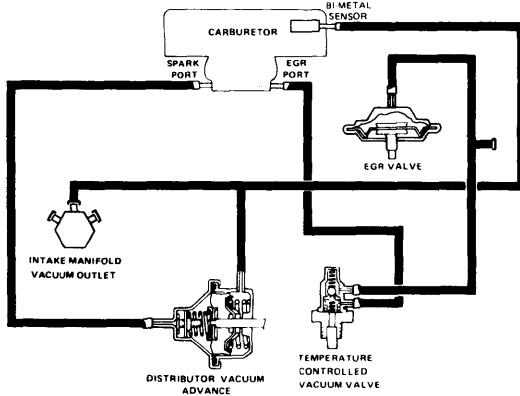

4FOE15

MAVERICK & COMET NON A/C

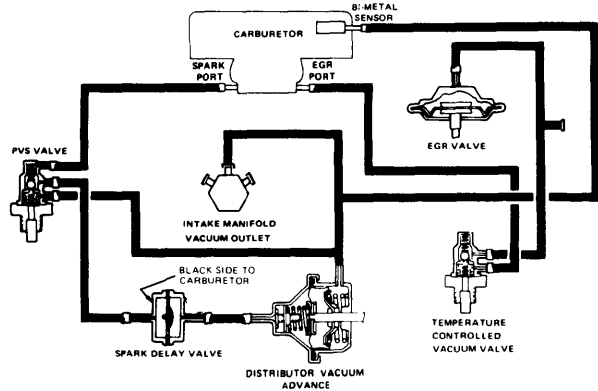

4FOE16

MAVERICK & COMET A/C

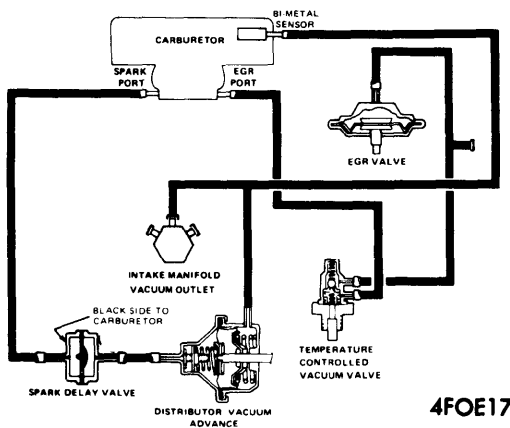

4FOE17

MAVERICK & COMET A/C

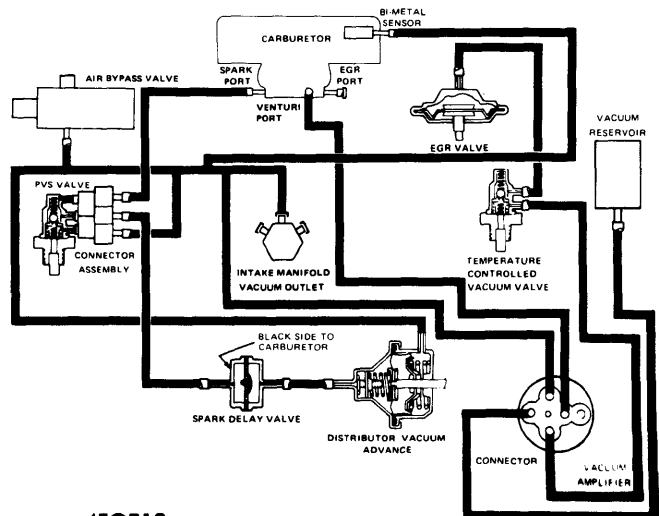

4FOE18

MAVERICK A/C

Exhaust Emission Systems

1974 FORD MOTOR CO. VACUUM DIAGRAMS (Cont.)

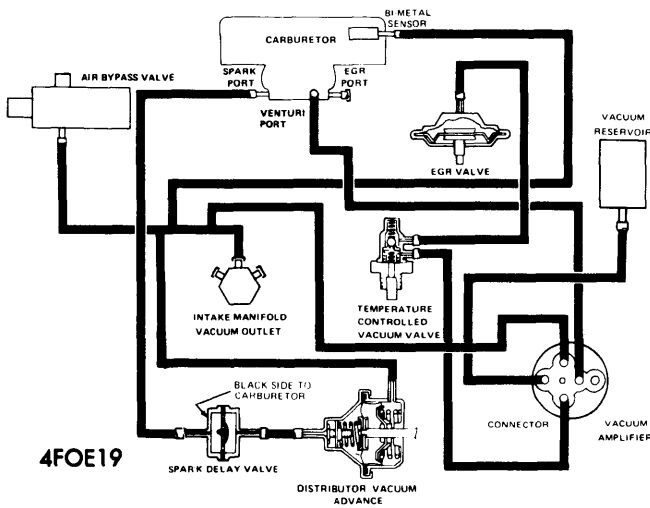

MAVERICK NON A/C

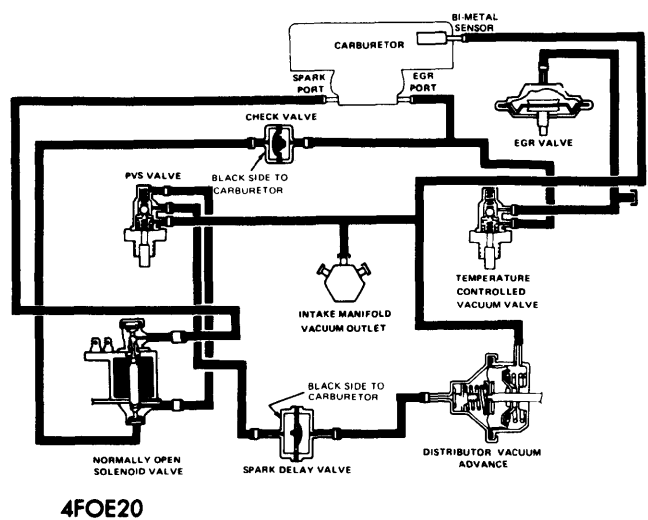

MAVERICK & COMET A/C

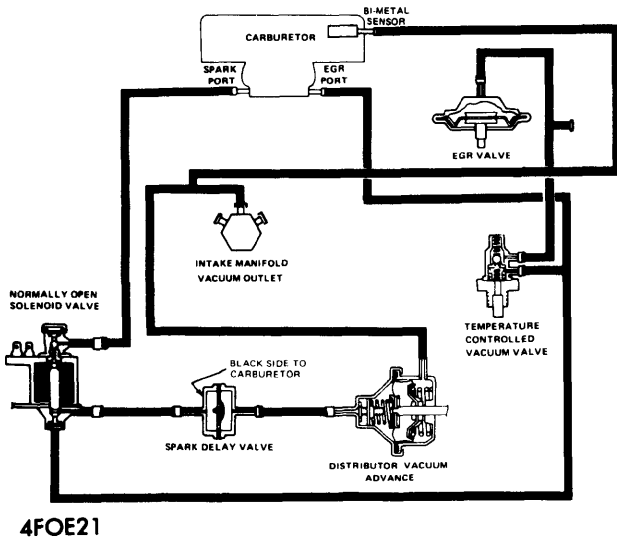

MAVERICK & COMET NON A/C

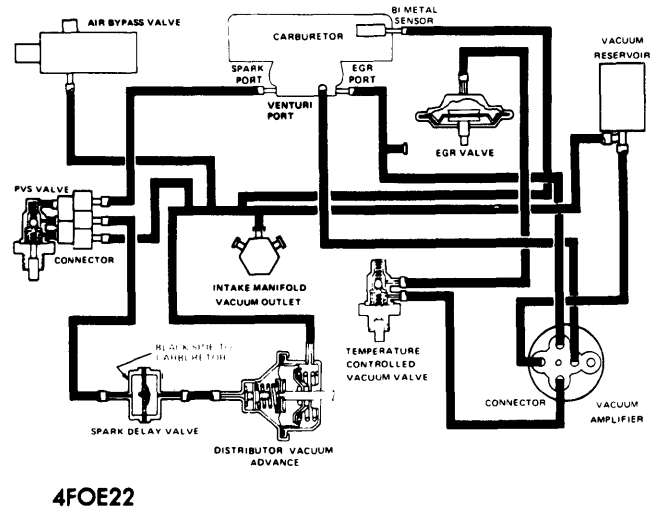

MAVERICK & COMET A/C

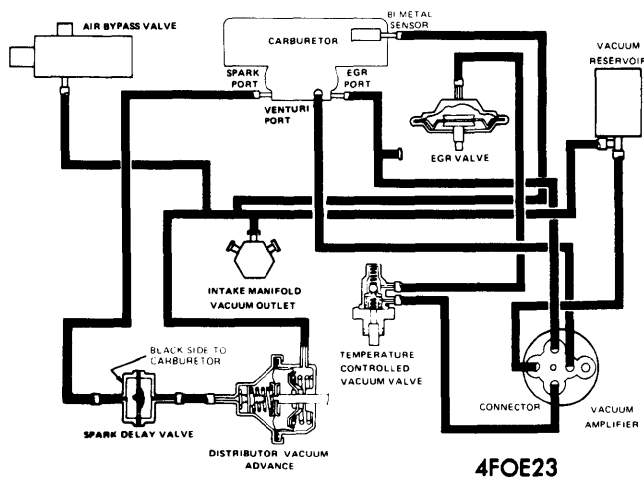

MAVERICK & COMET NON A/C

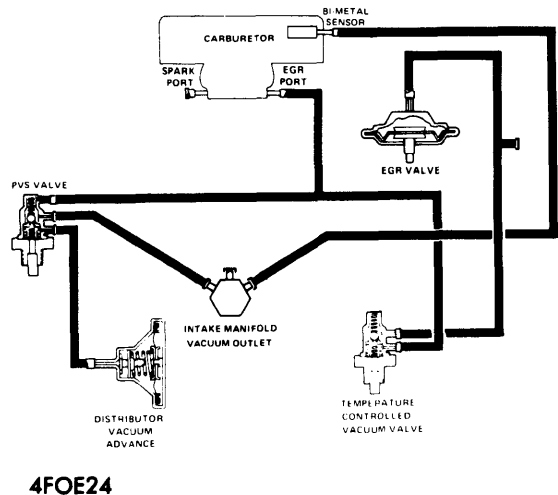

MAVERICK & COMET

Exhaust Emission Systems

1974 FORD MOTOR CO. VACUUM DIAGRAMS (Cont.)

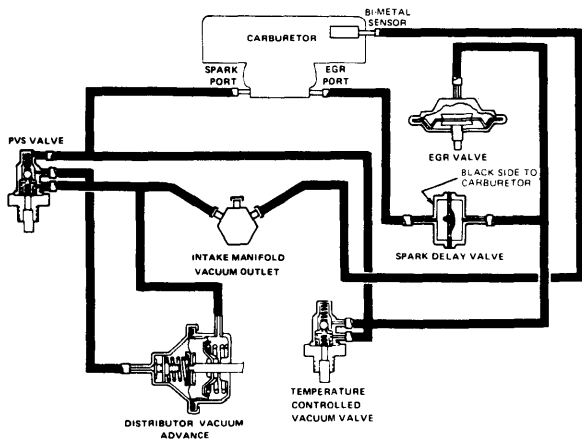

4FOE25

RANCHERO A/C

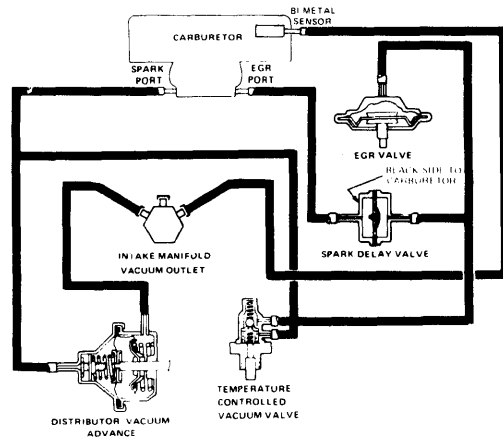

4FOE26

RANCHERO NON A/C

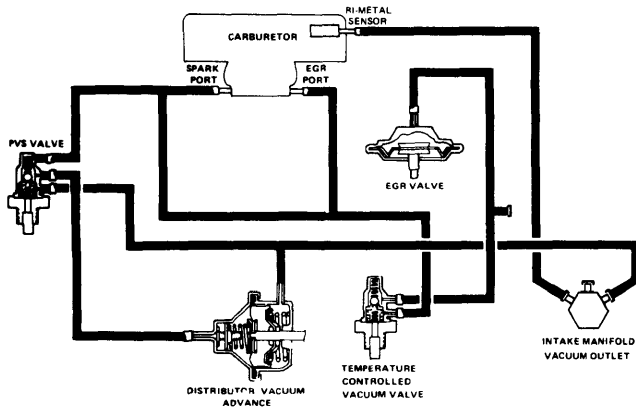

4FOE27

TORINO, MONTEGO A/C & H.D. CLUTCH

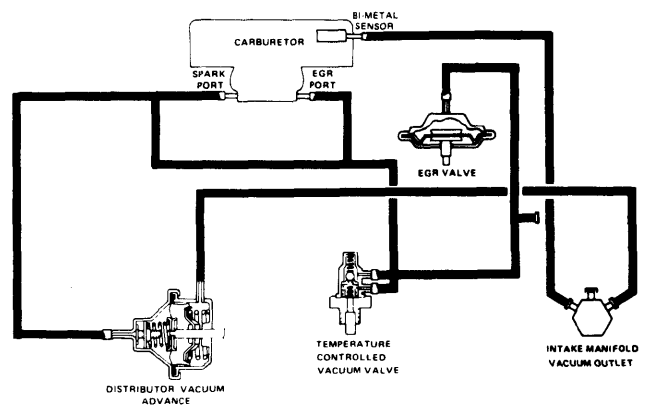

4FOE28

TORINO, MONTEGO NON A/C & H.D. CLUTCH

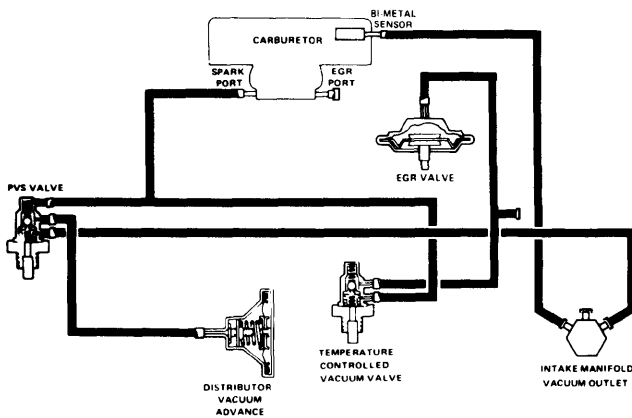

4FOE29

**MAVERICK, COMET
& TORINO, TORINO S.W., MONTEGO A/C**

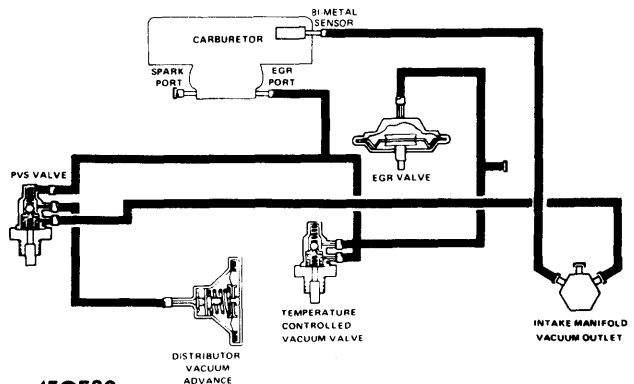

4FOE30

RANCHERO A/C, MAVERICK & COMET NON A/C

Exhaust Emission Systems

1974 FORD MOTOR CO. VACUUM DIAGRAMS (Cont.)

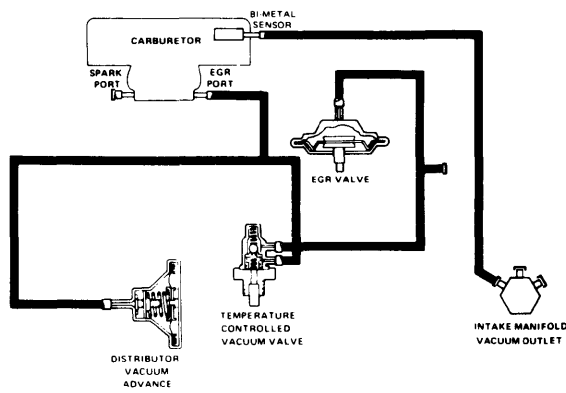

4FOE31

RANCHERO NON A/C

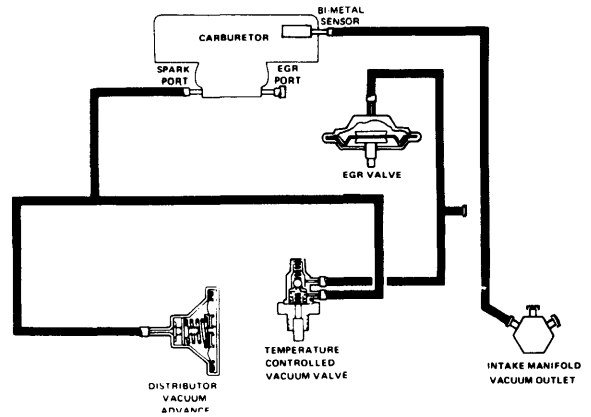

4FOE32

**TORINO, TORINO S.W.,
MONTEGO, FORD, MERCURY NON A/C**

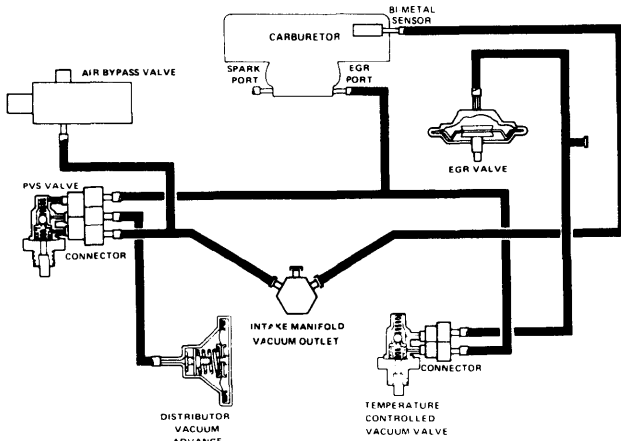

4FOE33

TORINO & MONTEGO S.W.

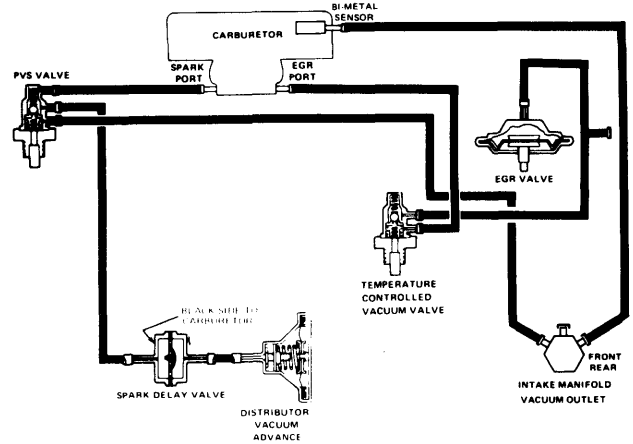

4FOE34

TORINO, MONTEGO, COUGAR

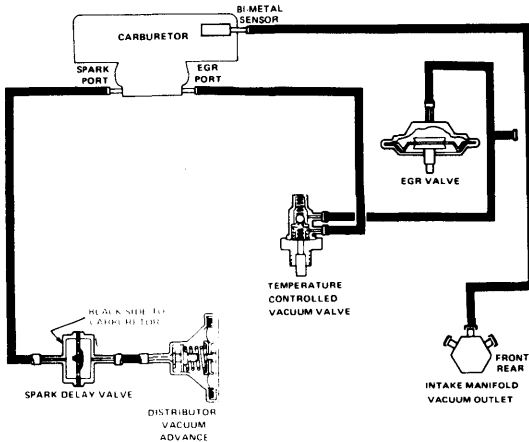

4FOE35

FORD, FORD H.T. & S.W., MERCURY S.W.

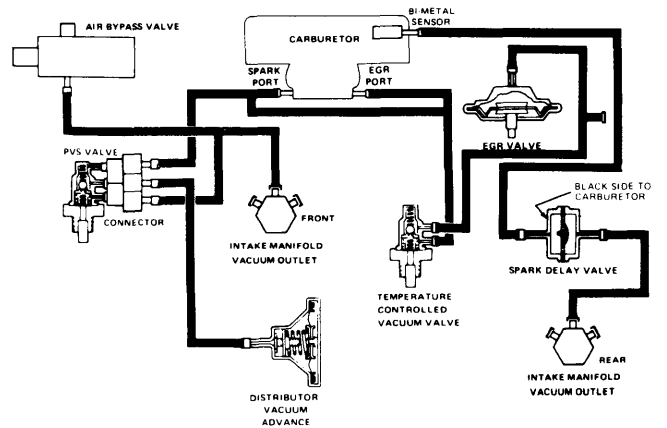

4FOE36

**TORINO,
MONTEGO SEDAN & S.W., COUGAR, RANCHERO**

1974 FORD MOTOR CO. VACUUM DIAGRAMS (Cont.)

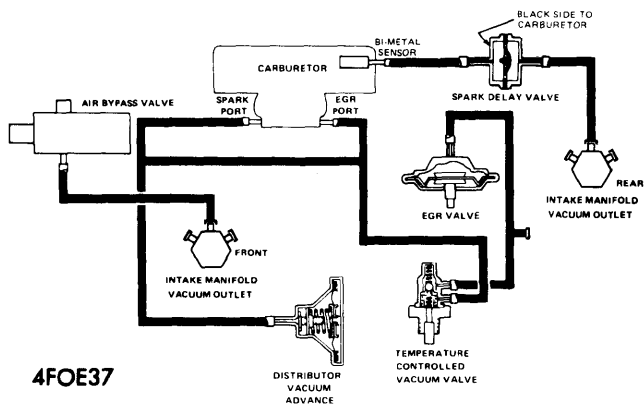

4FOE37

FORD, FORD S.W., MERCURY

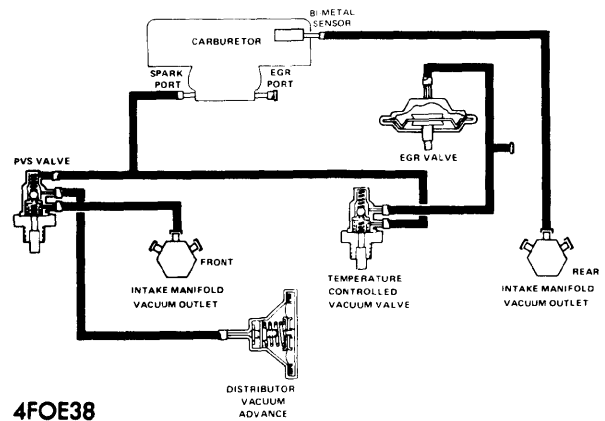

4FOE38

TORINO, MONTEGO, RANCHERO, COUGAR

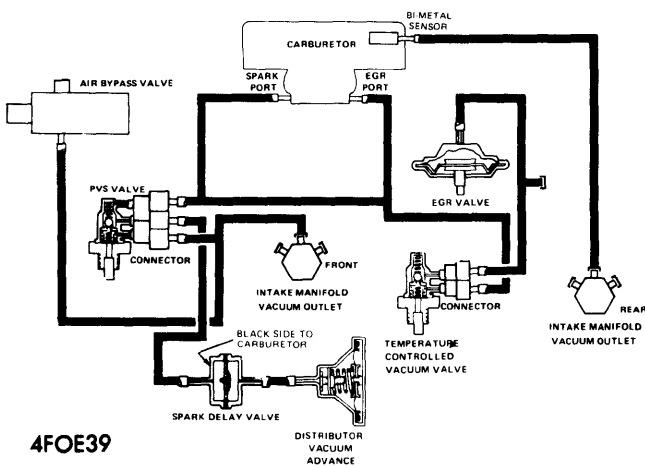

4FOE39

TORINO, MONTEGO, RANCHERO, COUGAR

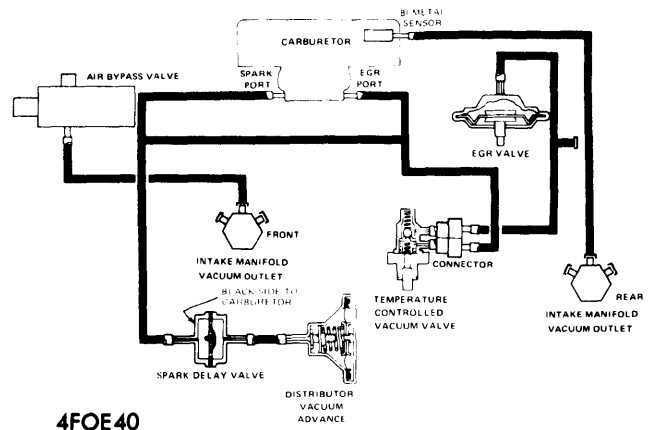

4FOE40

FORD, MERCURY S.W.

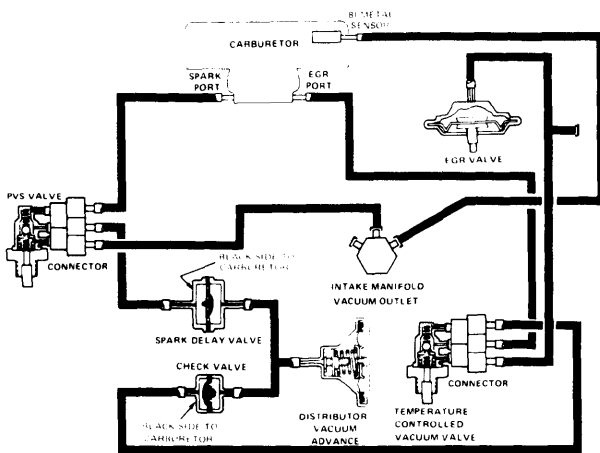

4FOE41

FORD, MONTEGO S.W.,
MERCURY, MERCURY S.W., T-BIRD, MARK IV,
LINCOLN, TORINO, COUGAR, TORINO S.W., RANCHERO

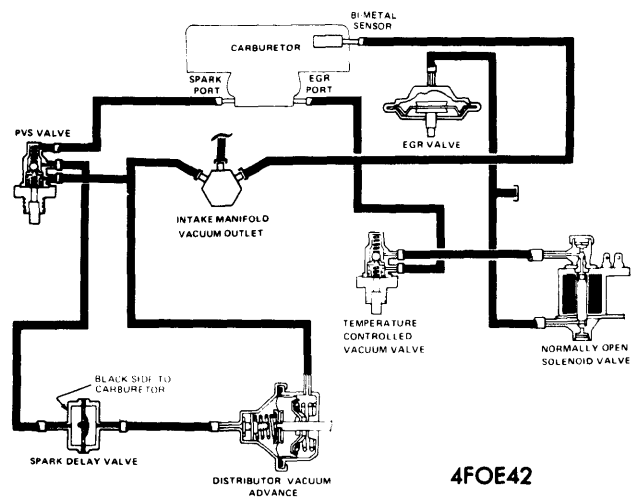

4FOE42

FORD, MERCURY, TORINO, MONTEGO

Exhaust Emission Systems

1974 FORD MOTOR CO. VACUUM DIAGRAMS (Cont.)

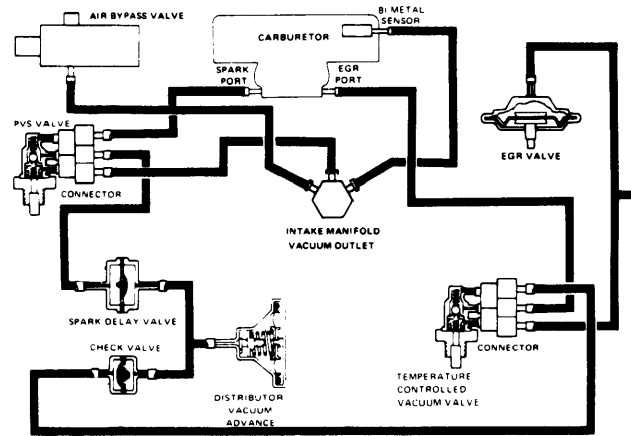

4FOE43

**TORINO, MONTEGO, COUGAR, MONTEGO S.W., TORINO S.W.,
FORD, MERCURY, MERCURY S.W., LINCOLN, MARK IV, T-BIRD**