

Exhaust Emission Systems

1968-74 FORD MOTOR CO. THERMOSTATIC AIR CLEANER

DESCRIPTION & OPERATION

A thermostatically controlled air cleaner is used on all 1968 and later cars. A valve, located within air duct assembly controls temperature of air entering carburetor, by either allowing heated air from a shroud around exhaust manifold or air from engine compartment to enter carburetor. Valve plate is controlled by either a thermostatic bulb (in air duct) or a vacuum operated motor. On some air cleaners an auxiliary air inlet valve is incorporated. A vacuum override motor is also used on 1968-70 air cleaners.

Vacuum Override Motor (1968-70) – During cold acceleration periods, additional carburetor intake air is provided by vacuum override motor control. Decrease in intake manifold vacuum during acceleration causes vacuum override motor to override thermostat control. This opens system to both engine compartment air and heated air from exhaust manifold shroud.

Temperature Operated Duct & Valve Assembly (1971-74) – A temperature operated duct and valve assembly is used on most engines. A thermostatic bulb in air duct is exposed to incoming air. A spring-loaded valve plate is connected to thermostatic bulb through linkage. Valve plate spring holds valve in closed position (heat on) until thermostatic bulb overcomes spring tension and open valve plate.

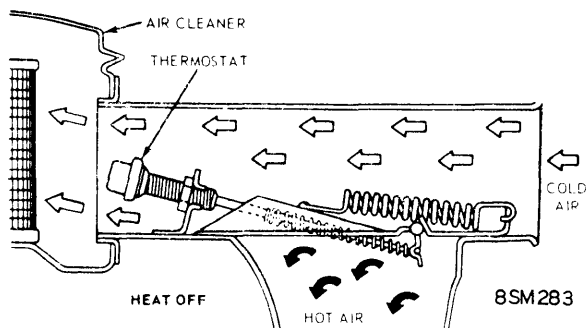

TEMPERATURE OPERATED DUCT & VALVE ASSEMBLY

Vacuum Operated Duct & Valve Assembly (1971-74) – Vacuum is controlled by a bi-metal switch located in air cleaner assembly. When engine compartment temperature is below approximately 80°F, switch is closed allowing vacuum to pass through switch and close door to engine compartment air. Warm air is then drawn from shroud around exhaust manifold. When temperature reaches 80°F, bi-metal switch opens and bleeds off vacuum. Without vacuum, hot air door is shut and carburetor receives air from engine compartment.

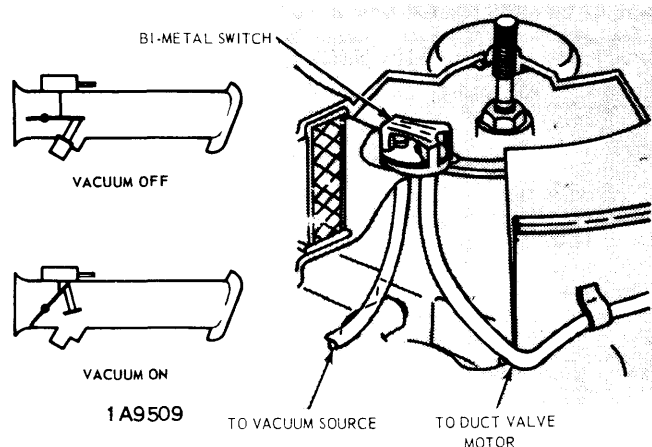

VACUUM OPERATED DUCT & VALVE ASSEMBLY

Auxiliary Air Inlet Valve – Additional carburetor air, during acceleration and full throttle periods, is provided by the auxiliary air inlet valve on the side of the air cleaner. The decrease in intake manifold vacuum during acceleration and full throttle periods causes vacuum motor to open the auxiliary air inlet valve. This provides carburetor intake system with additional engine compartment air.

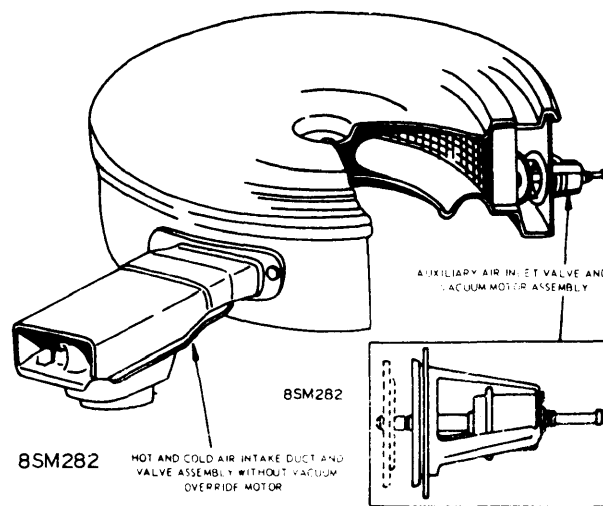

AUXILIARY INLET VALVE ASSEMBLY

TESTING

Thermostatic Bulb Test – Place duct assembly in water, be sure it is completely covered. Valve should be closed (heat on) position. Heat water to 100° F, allow 5 minutes to stabilize temperature. Valve should be in the heat on position. Increase temperature to 135° F, allow time to stabilize, valve should be in heat off position. If valve operation is unsatisfactory, and there is no plate and duct interference, and thermostat cannot be adjusted (1968-70 only), then duct and valve assembly should be replaced.

Vacuum Override Motor Test – With duct assembly installed on car, engine cold and engine compartment temperature less than 100° F, valve plate should be in approximately half open position. If not, check for possible interference of plate, duct and vacuum motor which would cause binding. Start engine and observe valve plate position while engine

1968-74 FORD MOTOR CO. THERMOSTATIC AIR CLEANER (Cont.)

is cold. Plate should be in full heat on position. If valve remains in half open position, remove vacuum hose at override vacuum motor and check for vacuum. If vacuum is less than 15" Hg, check for vacuum leaks. If vacuum is sufficient, and no binding exists, remove vacuum motor and connect to another vacuum source. If motor rod moves a minimum of $\frac{1}{2}$ ", motor is functioning correctly and should be reinstalled and a check made for interference and misalignment along with a check of thermostatic bulb. If motor rod does not move a minimum of $\frac{1}{2}$ ", motor is defective and should be replaced.

Vacuum Operated Duct & Valve Assembly – Duct valve should be open when engine is off. Start engine, valve should close during engine idle unless engine has reached normal operating temperature. If engine is cold and valve does not close during idle, check for disconnected vacuum lines to vacuum motor and bi-metal switch. Check bi-metal switch to see that bleed valve is closed. Open and close throttle rapidly. Valve should open during throttle opening. If valve does not function properly, check for a binding condition.

Bi-Metal Switch – Switch can be checked by subjecting switch to heated air or removing and immersing switch in water heated to 80° F. Only slight movement of the bi-metal is necessary to unseat the bleed valve.

Auxiliary Air Inlet Valve – Start engine and observe vacuum motor plate, it should be fully closed. Disconnect vacuum hose at vacuum motor, plate should be in full open position. If positions described above are not obtained, check for interference and alignment of plate and motor rod and vacuum from hose at the vacuum motor (minimum 15" Hg.). **NOTE** – If vacuum is not available, check hose and connection for leaks. If vacuum motor plate still remains in one position, remove vacuum motor from air cleaner and connect

it to another vacuum source to confirm that vacuum motor is not operating. If motor rod does not move when vacuum is applied, motor is defective and should be replaced.

ADJUSTMENT

Thermostatic Bulb Adjustment (1968-70) – Air intake duct thermostatic valve can be adjusted to change air temperature at which valve opens. Loosen jamb nut and turn thermostat clockwise to move valve toward heat-off position, or counterclockwise to move valve toward heat-on position. All adjustments must be verified by testing opening temperature. See "Testing" above for procedure.

