



1981 MITCHELL[®] ENGINE PERFORMANCE SERVICE & REPAIR

DOMESTIC CARS

TUNE-UP SPECIFICATIONS
Section T

TUNE-UP
Section 1

COMPUTERIZED ENGINE CONTROLS
Section 1a

FUEL SYSTEMS
Section 2

EXHAUST EMISSION SYSTEMS
Section 3

DISTRIBUTORS & IGNITION SYSTEMS
Section 4

Mitchell[®]

The Leader in Professional Estimating and Repair Information.



Mitchell International

ACKNOWLEDGMENT

Mitchell International thanks the domestic manufacturers, distributors and dealers for their generous cooperation and assistance which make this manual possible.

Chrysler Motors
Ford Motor Company
General Motors Corporation

MARKETING

Director
David R. Koontz

EDITORIAL

Senior Vice President
& Editor-in-Chief
Larry Laumann

Manager, Annual Data Editorial
Thomas L. Landis

Manager, Special Product Editorial
Ronald E. Garrett

Senior Editors
Daniel D. Fleming
Chuck Vedra
Ramiro Gutierrez
John M. Fisher
Tom L. Hall
James A. Hawes
Serge G. Pirino

Technical Editors
Scott A. Olsen
Bob Reel
David W. Himes
Alex A. Solis

Technical Editors (Cont.)

Donald T. Pellettera
David C. Rust
Reginald L. Baldwin
Michael C. May
KC Rosendale
Scott A. Tiner
James R. Warren
James D. Boxberger
David M. Finley
Raymond C. Day
Bobby R. Gifford
Linda M. Murphy
Tim P. Lockwood
Dave L. Skora
James A. Wafford
Wayne D. Charbonneau

WIRING DIAGRAMS

Manager
Matthew Krimple
Senior Editor
Lloyd Adams
Electrical Editors
Leonard McVicker
Santiago Llano
Harry Piper
Richard B. Speake
Robert Klempan

QUALITY ASSURANCE

Manager
Daryl F. Visser
Sr. QA Specialist
Nick DiVerde
QA Specialists
Trang Nguyen
Brian W. Hutchins
Julia A. Kinneer
Julia R. Selverstone

BOOK PRODUCTION

Roger Leftridge

TECHNICAL LIBRARIAN

Charlotte Norris

PRODUCT SUPPORT

Supervisor
Patrick G. San Nicolas
Product Specialists
Robert L. Rothgery
William E. Bond

GRAPHICS

Manager
Judie LaPierre
Supervisor
Ann Klimetz

Published By

MITCHELL INTERNATIONAL
9889 Willow Creek Road
P.O. Box 26260
San Diego, California 92196-0260

ISBN 0-8470-0223-3

Copyright © 1990 Mitchell International
All Rights Reserved

Customer Service Numbers:

Subscription/Billing Information:
1-800-648-8010 or 619-578-6550

Technical Information:
1-800-854-7030 or 619-578-6550

Or Write: P.O. Box 26260, San Diego, CA 92196-0260

DISCLAIMER OF WARRANTIES: Although the information contained within this volume has been obtained from sources generally believed to be reliable, no warranty (expressed or implied) can be made as to its accuracy or completeness, nor is any responsibility assumed by Mitchell International or anyone connected with it for loss or damages suffered through reliance on any information contained in this volume. SPECIFICALLY, NO WARRANTY OF MERCHANTABILITY, FITNESS FOR A PARTICULAR PURPOSE OR ANY OTHER WARRANTY IS MADE OR TO BE IMPLIED WITH RESPECT TO THIS VOLUME AND ITS CONTENTS. In no event will Mitchell International be liable for any damages, direct or indirect, consequential or compensatory, including, without limitation, lost profits, for any representations, breaches or defaults arising out of the use of this volume. Customer agrees to indemnify Mitchell International and hold it harmless against all claims and damages, including without limitation, reasonable attorney's fees arising out of the use of this volume, unless such claims or damages result from the infringement of any copyright or other proprietary right of any third party.

INTRODUCTION

This is the 1981 Supplement to Mitchell's Domestic Car Engine Performance Manual. In it you will find complete service information for Tune-Up, Computerized Engine Controls, Fuel Systems, Exhaust Emission Systems, and Distributors & Ignition Systems. This combination provides the most comprehensive and detailed information available on these systems.

Finding the Information

To find information for the vehicle on which you are working, simply turn to the contents page located at the beginning of the appropriate section. Here you will find alphabetical listings of models grouped according to subject. Just determine the proper page number, and turn to the corresponding article, or use the handy General Index that follows this Introduction.

Description

TUNE-UP SPECIFICATIONS

Section T

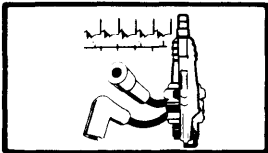

In this section you will find all Tune-Up Specifications listed in chart form. This is for fast reference when you need Ignition or Fuel System Specifications.

TUNE-UP

Section 1

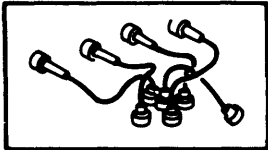

The TUNE-UP section is divided by engine size. Included in this section are Engine Identification, Tune-Up Procedures, Belt Adjustments, Filter and Cleaner Service Intervals and Refill Capacities.

COMPUTERIZED ENGINE CONTROLS

Section 1a

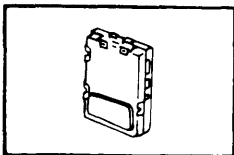

The COMPUTERIZED ENGINE CONTROLS section provides detailed coverage of all Computerized Engine Control Systems. Included are Trouble Shooting Charts, Diagnostic Codes and complete Wiring Diagrams for all control systems. In-depth Description and Operation information clarifies the inner workings of these complex systems.

FUEL SYSTEMS

Section 2

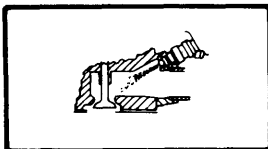

The FUEL SYSTEMS section covers such vital points as Carburetors, Fuel Injection, Turbocharger, Fuel Pumps and Trouble Shooting. Complete Specification Tables and exploded views of carburetors are included. Step-by-step procedures, supported by concise and detailed illustrations, make any fuel system repair easier and faster.

INTRODUCTION

Description (Cont.)

EXHAUST EMISSION SYSTEMS

Section 3

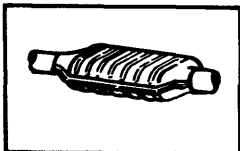

The beginning of this section includes emission control system applications. Each model and engine application requires a different combination of systems to meet Clean Air Standards. This section explains major Emission Systems and their components, Testing, Trouble Shooting and Adjustment procedures.

DISTRIBUTORS & IGNITION SYSTEMS

Section 4

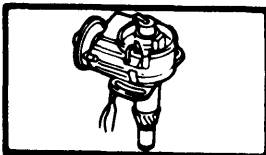

In the DISTRIBUTORS & IGNITION SYSTEMS section, you will find complete Testing & Diagnosis procedures. Exploded Views and complete Specifications help make repairs easier and more accurate.

GENERAL INDEX

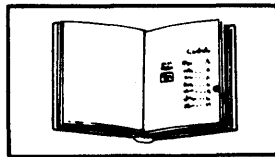

CONTENTS

MANUFACTURER	Page
American Motors	1-2
Chrysler Corp.	1-3
Ford Motor Co.	1-5
General Motors	1-7

NOTE: ALSO SEE SECTION CONTENT PAGES

1981 American Motors Index

A

APPLICATIONS

Emission Control Applications	3-10
Tool Applications	G-4

AUTOMATIC CHOKE - See Carburetor

B

BATTERY

Cold Cranking Amps	
4-Cylinder	1-7
6-Cylinder	1-11

BELT

Accessory Drive	
4-Cylinder	1-8
6-Cylinder	1-11

C

CAPACITIES - See Fuel Tank or Oil

CATALYTIC CONVERTERS - See Exhaust Emission Systems

CARBURETOR

151" 4-Cylinder Rochester 2SE & E2SE	
Adjustment	2-55
Application	2-54
Description	2-54
Identification	2-54
Overhaul	2-59
Specifications	2-63
Trouble Shooting	2-2
258" 6-Cylinder Carter BBD	
Adjustments	2-7
Application	2-7
Description	2-7
Identification	2-7
Overhaul	2-10
Specifications	2-12
Trouble Shooting	2-2

COMPRESSION PRESSURE

4-Cylinder	1-5
6-Cylinder	1-9

COMPUTERIZED ENGINE CONTROLS

Introduction	1a-2
Computer Controlled Catalytic Converter	
4-Cylinder (Calif. Only)	
Description	1a-4
Diagnosis & Testing	1a-5
Diagnostic Procedure	1a-6
Maintenance	1a-11
Removal & Installation	1a-11
Computerized Emission Control	
6-Cylinder	
Description & Operation	1a-13
Maintenance	1a-24
Removal & Installation	1a-24
Diagnosis & Testing	1a-15

CRANKCASE - See Oil

D

DISTRIBUTOR

4-Cylinder	
Description & Operation	4-19
Overhaul	4-21
Specifications	4-3
Testing	4-19
6-Cylinder	
Description & Operation	4-30
Overhaul	4-33
Specifications	4-3
Testing	4-31

E

EXHAUST EMISSION SYSTEMS

Air Injection System	
Description & Operation	3-13
Testing	3-14
Catalytic Converters	
Catalyst Replacement	3-6
Description & Operation	3-5
Service	3-5
Emission Application Table	3-10
Emission Standards	3-2
Exhaust Gas Recirculation (EGR)	
Description	3-11
Maintenance	3-12
Testing	3-12
Trouble Shooting	3-12
Fuel Vapor Control System	3-15
Positive Crankcase Ventilation	
Description & Operation	3-3
Service Procedures	3-4
Testing	3-3
Thermostatic Air Cleaners	
Description & Operation	3-7
Testing	3-8
Vacuum Diagrams	3-16

F

FILTER

Service Intervals	
4-Cylinder	1-8
6-Cylinder	1-11

FIRING ORDER

4-Cylinder	1-5
6-Cylinder	1-9

FUEL PUMP

Specifications	
4-Cylinder	1-7
6-Cylinder	1-10

FUEL TANK

Capacity	
4-Cylinder	1-8
6-Cylinder	1-11

I

IDENTIFICATION - See Vehicle Identification Number

IGNITION

4-Cylinder	
Description & Operation	4-19
Overhaul	4-21
Specifications	4-3
Testing	4-19
6-Cylinder	
Description & Operation	4-30
Overhaul	4-33
Specifications	4-3
Testing	4-31

M

MAINTENANCE REMINDER LIGHTS

1981 Reset Procedures	G-2
-----------------------------	-----

O

OIL

Capacity	
4-Cylinder	1-8
6-Cylinder	1-11

S

SPARK PLUGS

Application & Torque	
4-Cylinder	1-5
6-Cylinder	1-9

T

TIMING

Ignition	
4-Cylinder	1-5
6-Cylinder	1-9

TROUBLE SHOOTING

Carburetor	2-2
Ignition System	4-2
Tune-Up	1-2

TUNE-UP

4-Cylinder	1-5
6-Cylinder	1-9

V

VALVE

Clearance	
4-Cylinder	1-5
6-Cylinder	1-9

VEHICLE IDENTIFICATION NUMBER

4-Cylinder	1-5
6-Cylinder	1-9
VIN Code Explanation	G-3

W

WIRE RESISTANCE

4-Cylinder	1-5
6-Cylinder	1-9

A

APPLICATIONS

Emission Control Applications	3-18
Tool Applications	G-4

AUTOMATIC CHOKE - See Carburetor

B

BATTERY

Cranking Amps	
4-Cylinder	1-15
6-Cylinder	1-19
V8	1-23

BELT

Accessory Drive	
4-Cylinder	1-15
6-Cylinder	1-19
V8	1-23

C

CAPACITIES - See Fuel Tank or Oil

CARBURETOR

135" 4-Cylinder (Holley 6520)	
Adjustments	2-33
Application	2-33
Description	2-33
Identification	2-33
Overhaul	2-36
Specifications	2-36
Trouble Shooting	2-2
156" 4-Cylinder (Mikuni)	
Adjustment	2-20
Application	2-20
Description	2-20
Identification	2-20
Overhaul	2-20
Trouble Shooting	2-2
225" 6-Cylinder (Holley 1945)	
Adjustment	2-23
Application	2-23
Description	2-23
Identification	2-23
Overhaul	2-25
Specifications	2-27
Trouble Shooting	2-2
225" 6-Cylinder (Holley 6145)	
Adjustment	2-28
Application	2-28
Description	2-28
Identification	2-28
Specifications	2-28
Trouble Shooting	2-2
318" V8 (Carter BBD)	
Adjustments	2-7
Application	2-7
Description	2-7
Identification	2-7
Overhaul	2-10
Specifications	2-12
Trouble Shooting	2-2

318" V8 (Carter Thermo-Quad)

Adjustment	2-13
Application	2-13
Description	2-13
Identification	2-13
Overhaul	2-17
Specifications	2-19
Trouble Shooting	2-2

CATALYTIC CONVERTERS - See Exhaust Emission Systems

COMPRESSION PRESSURE

4-Cylinder	1-12
6-Cylinder	1-17
V8	1-20

COMPUTERIZED ENGINE CONTROLS

Introduction	1a-2
Chrysler Corp. Combustion Control Computer	
Imperial	
Adjustment	1a-37
Description	1a-32
Diagnosis & Testing	1a-33
Operation	1a-33
Chrysler Corp. Electronic Fuel Control	
4-Cylinder Equipped Models	
Description	1a-26
Maintenance	1a-30
Operation	1a-26
Removal & Installation	1a-30
Testing	1a-28
6-Cyl. & V8 Equipped Models (Exc. Imperial)	
Description	1a-38
Maintenance	1a-45
Operation	1a-38
Removal & Installation	1a-45
Testing	1a-41

CRANKCASE - See Oil

D

DISTRIBUTOR

135" (2.2L) 4-Cylinder	
Hall Effect Electronic	
Adjustments	4-7
Description	4-7
Operation	4-7
Overhaul	4-10
Testing	4-8
156" (2.6L) 4-Cylinder	
Mitsubishi Electronic	
Adjustments	4-11
Description	4-11
Operation	4-11
Overhaul	4-12
Testing	4-11
225" (3.7L) 6-Cylinder	
Chrysler Corp. Electronic	
Adjustment	4-5
Description	4-4
Operation	4-4
Overhaul	4-6
Specifications	4-3
Testing	4-5
225" (3.7L) 6-Cylinder & 318" (5.2L) V8	
Electronic Spark Control	
Description	4-14
Operation	4-15
Overhaul	4-18
Specifications	4-3
Testing	4-15

E

EXHAUST EMISSION SYSTEMS

Air Injection Systems	
Description	3-23
Operation	3-23
Service Procedures	3-24
Testing	3-24
Catalytic Converters	
Description & Operation	3-5
Service	3-5
Emission Application Table	3-18
Emission Standards	3-2
Evaporation Control System	
Description	3-25
Operation	3-25
Maintenance	3-25
Exhaust Gas Recirculation	
Description	3-19
Operation	3-19
Servicing	3-21
Testing	3-20
Trouble Shooting	3-21
Positive Crankcase Ventilation	
Description	3-3
Operation	3-3
Service Procedures	3-4
Testing	3-3
Thermostatic Air Cleaners	
Description	3-7
Operation	3-7
Testing	3-8
Vacuum Diagrams	3-26

F

FILTER

Service Intervals	
4-Cylinder	1-16
6-Cylinder	1-19
V8	1-23

FIRING ORDER

4-Cylinder	1-13
6-Cylinder	1-17
V8	1-20

FUEL INJECTION

Electronic Fuel Injection	
Adjustment	2-87
Description	2-83
Operation	2-83
Trouble Shooting	2-85

FUEL PUMP

Specifications	
4-Cylinder	1-15
6-Cylinder	1-19
V8	1-22

FUEL TANK

Capacity	
4-Cylinder	1-16
V8	1-23

1981 Chrysler Corp. Index (Cont.)

I

IDENTIFICATION - See *Vehicle Identification Number*

IGNITION

135" (2.2L) 4-Cylinder
Hall Effect Electronic

- Adjustments 4-7
- Description 4-7
- Operation 4-7
- Overhaul 4-10
- Testing 4-8

156" (2.6L) 4-Cylinder
Mitsubishi Electronic

- Adjustments 4-11
- Description 4-11
- Operation 4-11
- Overhaul 4-12
- Testing 4-11

225" (3.7L) 6-Cylinder
Chrysler Corp. Electronic Ignition

- Adjustment 4-5
- Description 4-4
- Operation 4-4
- Overhaul 4-6
- Specifications 4-3
- Testing 4-5

225" (3.7L) 6-Cylinder & 318" (5.2L) V8
Electronic Spark Control

- Description 4-14
- Operation 4-15
- Overhaul 4-18
- Specifications 4-3
- Testing 4-15

INJECTION - See *Fuel Injection*

L

LUBRICATION - See *Oil*

M

MAINTENANCE REMINDER LIGHTS

1981 Reset Procedures G-2

O

OIL

Capacity

- 4-Cylinder 1-16
- V8 1-23

S

SPARK PLUGS

Application & Torque

- 4-Cylinder 1-12
- 6-Cylinder 1-17
- V8 1-20

T

TIMING

Ignition

- 4-Cylinder 1-13
- 6-Cylinder 1-17
- V8 1-21

TROUBLE SHOOTING

- Carburetor 2-2
- Ignition System 4-2
- Tune-Up 1-2

TUNE-UP

- 4-Cylinder 1-12
- 6-Cylinder 1-17
- V8 1-20

V

VALVE

Clearance

- 4-Cylinder 1-12
- 6-Cylinder 1-17
- V8 1-20

VEHICLE IDENTIFICATION NUMBER

- 4-Cylinder 1-12
- 6-Cylinder 1-17
- V8 1-20
- VIN Code Explanation G-3

W

WIRE RESISTANCE

- 4-Cylinder 1-12
- 6-Cylinder 1-17
- V8 1-20

A

APPLICATIONS

Emission Control Applications	3-28
Tool Applications	G-4

AUTOMATIC CHOKE - See Carburetor

B

BATTERY

Cranking Amps	
4-Cylinder	1-27
6-Cylinder	1-31
V8	1-35

BELT

Accessory Drive	
4-Cylinder	1-27
6-Cylinder	1-31
V8	1-36

C

CAPACITIES - See Fuel Tank or Oil

CARBURETOR

98" 4-Cylinder (Motorcraft 740)	
Adjustments	2-37
Application	2-37
Description	2-37
Identification	2-37
Overhaul	2-39
Specifications	2-40
Testing	2-37
Trouble Shooting	2-2
140" 4-Cylinder (Holley 6500)	
Adjustment	2-29
Application	2-29
Description	2-29
Identification	2-29
Overhaul	2-30
Specifications	2-32
Trouble Shooting	2-2
200" 6-Cylinder (Holley 1946)	
Adjustment	2-23
Application	2-23
Description	2-23
Identification	2-23
Overhaul	2-25
Specifications	2-27
Trouble Shooting	2-2
255" & 302" V8 (Motorcraft 2150)	
Adjustment	2-41
Application	2-41
Description	2-41
Identification	2-41
Overhaul	2-43
Specifications	2-45
Trouble Shooting	2-2

255", 302" & 351" V8 (Motorcraft 7200 VV)	
Adjustments	2-46
Application	2-46
Description	2-46
Identification	2-46
Overhaul	2-50
Specifications	2-53
Trouble Shooting	2-2

CATALYTIC CONVERTERS - See Exhaust Emission Systems

COMPRESSION PRESSURE

4-Cylinder	1-24
6-Cylinder	1-29
V8	1-32

COMPUTERIZED ENGINE CONTROLS

Introduction	1a-2
Electronic Engine Control III	
Description	1a-65
Diagnosis & Testing	1a-71
Operation	1a-65
Removal & Installation	1a-72
MCU Engine Control System	
Description	1a-47
Diagnosis & Testing	1a-49
Operation	1a-47
Sub-Routine Test Instructions	1a-51
4 & 6-Cyl. Sub-Routines	1a-53
V8 Sub-Routines	1a-59

CRANKCASE - See Oil

D

DISTRIBUTOR

Motorcraft Dura-Spark II Ignition	
Adjustments	4-36
Description	4-34
Operation	4-34
Overhaul	4-39
Specifications	4-3
Testing	4-36
Motorcraft EEC III Ignition	
Description	4-41
Operation	4-41
Overhaul	4-47
Specifications	4-3
Testing	4-44

E

EXHAUST EMISSION SYSTEMS

Catalytic Converters	
Description & Operation	3-5
Service	3-5
Cold Start Spark Advance System	
Description	3-40
Operation	3-40
Testing	3-40
Cold Start Spark Hold System	
Description	3-40
Operation	3-40
Testing	3-40

Distributor Vacuum Vent Valve	
Description	3-45
Operation	3-45
Testing	3-45
Electric Assist Choke	
Description	3-41
Operation	3-41
Testing	3-41
Emission Application Table	3-28
Emission Components	3-29
Emission Standards	3-2
Exhaust Gas Recirculation (EGR)	
Description	3-33
Operation	3-33
Trouble Shooting	3-34
Testing	3-34
Fuel Vapor Emission Control	
Description	3-42
Operation	3-42
Maintenance	3-43
Positive Crankcase Ventilation	
Description	3-3
Operation	3-3
Service Procedures	3-4
Testing	3-3
Spark Delay Valves	
Description & Operation	3-44
Testing	3-44
Thermactor Systems	
Description	3-36
Operation	3-36
Testing	3-38
Thermostatic Air Cleaners	
Description	3-7
Operation	3-7
Testing	3-8
Vacuum Diagrams	3-46

F

FILTER

Service Intervals	
4-Cylinder	1-28
6-Cylinder	1-31
V8	1-36

FIRING ORDER

4-Cylinder	1-24
6-Cylinder	1-29
V8	1-32

FUEL INJECTION

Electronic Fuel Injection	
Adjustments	2-94
Description	2-89
Operation	2-89
Removal & Installation	2-93
Testing & Diagnosis	2-91

FUEL PUMP

Specifications	
4-Cylinder	1-27
6-Cylinder	1-30
V8	1-35

FUEL TANK

Capacity	
4-Cylinder	1-28
6-Cylinder	1-31
V8	1-36

1981 Ford Motor Co. Index (Cont.)

I

IDENTIFICATION - *See Vehicle Identification Number*

IGNITION

Motorcraft Dura-Spark II Ignition	
Adjustments	4-36
Description	4-34
Operation	4-34
Overhaul	4-39
Specifications	4-3
Testing	4-36
Motorcraft EEC III Ignition	
Description	4-41
Operation	4-41
Overhaul	4-47
Specifications	4-3
Testing	4-44

INJECTION - *See Fuel Injection*

M

MAINTENANCE REMINDER LIGHTS

1981 Reset Procedures	G-2
-----------------------------	-----

O

OIL

Capacity	
4-Cylinder	1-28
6-Cylinder	1-31
V8	1-36

S

SPARK PLUGS

Application & Torque	
4-Cylinder	1-24
6-Cylinder	1-29
V8	1-32

T

TIMING

Ignition	
4-Cylinder	1-25
6-Cylinder	1-29
V8	1-33

TROUBLE SHOOTING

Carburetor	2-2
Ignition	4-2
Tune-Up	1-2

TUNE-UP

4-Cylinder	1-24
6-Cylinder	1-29
V8	1-32

V

VALVE

Clearance	
4-Cylinder	1-24
6-Cylinder	1-29
V8	1-32

VEHICLE IDENTIFICATION NUMBER

4-Cylinder	1-24
6-Cylinder	1-29
V8	1-32
VIN Code Explanation	G-3

W

WIRE RESISTANCE

4-Cylinder	1-24
6-Cylinder	1-29
V8	1-32

A

APPLICATIONS

Emission Control Applications	3-61
Tool Applications	G-4

AUTOMATIC CHOKE - See Carburetor

B

BATTERY

Cranking Amps	
4-Cylinder Gas	1-40
V6 Gas	1-44
V8 Diesel	1-53
V8 Gas	1-50

BELT

Accessory Drive	
4-Cylinder Gas	1-40
V6 Gas	1-45
V8 Diesel	1-54
V8 Gas	1-51

C

CAPACITIES - See Oil

CARBURETOR

98" 4-Cylinder (Holley 6510-C)	
Adjustments	2-33
Application	2-33
Description	2-33
Identification	2-33
Overhaul	2-36
Specifications	2-36
Trouble Shooting	2-2
151" 4-Cyl. & 173" V6 (Rochester E2SE)	
Adjustment	2-55
Application	2-54
Description	2-54
Identification	2-54
Overhaul	2-59
Specifications	2-63
Trouble Shooting	2-2
229" & 231" V6 & 260", 265" & 267" V8 (Rochester E2MC & E2ME)	
Adjustment	2-64
Application	2-64
Description	2-64
Identification	2-64
Overhaul	2-68
Specifications	2-70
Trouble Shooting	2-2
231" & 252" V6 & 301", 305" & 350" V8 (Rochester E4MC & E4ME)	
Adjustments	2-73
Application	2-73
Description	2-73
Identification	2-73
Overhaul	2-79
Specifications	2-82
Trouble Shooting	2-2

CATALYTIC CONVERTERS - See Exhaust Emission Systems

COMPRESSION PRESSURE

4-Cylinder Gas	1-37
V6 Gas	1-41
V8 Diesel	1-52
V8 Gas	1-46

COMPUTERIZED ENGINE CONTROLS

Computer Command Control	
Buick, Cadillac, Chevrolet, Oldsmobile & Pontiac	
Description & Operation	1a-73
Diagnosis & Testing	1a-77
Diagnostic Procedure	1a-78
Maintenance	1a-95
Removal & Installation	1a-95
DFI Control System	
Description & Operation	1a-97
Diagnosis & Testing	1a-100
Diagnostic Procedure	1a-101
Maintenance	1a-121
Performance Charts	1a-115
Removal & Installation	1a-121
Trouble Code Charts	1a-103

CRANKCASE - See Oil

D

DISTRIBUTOR

Delco-Remy Electronic Spark Timing (EST)	
Description	4-23
Operation	4-23
Overhaul	4-28
Pre-Testing Diagnosis	4-25
Testing	4-25
Delco-Remy Electronic Module Retard Ignition	
Description	4-29
Operation	4-29
Overhaul	4-29
Testing	4-29

E

EXHAUST EMISSION SYSTEMS

Air Injection Reactor	
Description	3-76
Operation	3-76
Testing	3-76
Trouble Shooting	3-77
Catalytic Converters	
Catalyst Replacement	3-6
Description & Operation	3-5
Service	3-5
Early Fuel Evaporation (EFE)	
Description	3-69
Operation	3-69
Testing	3-69
Evaporative Control System	
Description	3-79
Operation	3-79
Maintenance	3-80
Emission Application Tables	3-61

Emission Standards	3-2
Exhaust Gas Recirculation (EGR)	
Gasoline Models	
Description	3-71
Operation	3-71
Maintenance	3-73
Testing	3-73
Trouble Shooting	3-72
Diesel Models	
Description	3-74
Operation	3-74
Trouble Shooting	3-75
Positive Crankcase Ventilation	
Description	3-3
Operation	3-3
Service Procedures	3-4
Testing	3-3
Pulse Air Injection Reactor	
Description	3-78
Operation	3-78
Testing	3-78
Trouble Shooting	3-78
Thermostatic Air Cleaners	
Description	3-7
Operation	3-7
Testing	3-8
Valves, Switches and Solenoids	3-66
Vacuum Diagrams	3-81

F

FILTER

Service Intervals	
4-Cylinder Gas	1-40
V6 Gas	1-45
V8 Diesel	1-54
V8 Gas	1-51

FIRING ORDER

4-Cylinder Gas	1-37
V6 Gas	1-41
V8 Diesel	1-52
V8 Gas	1-47

FUEL INJECTION

Diesel Mechanical Fuel Injection	
Adjustment	2-107
Description	2-101
Operation	2-101
Removal & Installation	2-104
Testing	2-103
Trouble Shooting	2-4
Digital Fuel Injection (DFI)	
Adjustments	2-99
Description	2-95
Operation	2-95
Removal & Installation	2-98
Trouble Shooting & Diagnosis	2-96

FUEL PUMP

Specifications	
4-Cylinder Gas	1-39
V6 Gas	1-44
V8 Gas	1-50

1981 General Motors Index (Cont.)

G

GLOW PLUGS

Diesel Engine	
Description	2-101
Removal & Installation	2-107

I

IDENTIFICATION - See *Vehicle Identification Number*

IGNITION

Delco-Remy Electronic Spark Timing (EST)	
Description	4-23
Operation	4-23
Overhaul	4-28
Pre-Testing Diagnosis	4-25
Testing	4-25
Delco-Remy Electronic Module Retard Ignition	
Description	4-29
Operation	4-29
Overhaul	4-29
Testing	4-29

INJECTION - See *Fuel Injection*

M

MAINTENANCE REMINDER LIGHTS

1981 Reset Procedures	G-2
-----------------------------	-----

O

OIL

Capacity	
4-Cylinder Gas	1-40
V6 Gas	1-45
V8 Diesel	1-54
V8 Gas	1-51

S

SPARK PLUGS

Application & Torque	
4-Cylinder Gas	1-37
V6 Gas	1-41
V8 Gas	1-46

T

TIMING

Diesel Injection Pump	1-52, 2-107
Ignition	
4-Cylinder Gas	1-38
V6 Gas	1-42
V8 Gas	1-47

TROUBLE SHOOTING

Carburetor	2-2
Diesel Fuel Injection	2-4
Ignition System	4-2
Tune-Up	1-2
Turbochargers	2-6

TUNE-UP

4-Cylinder Gas	1-37
V6 Gas	1-41
V8 Diesel	1-52
V8 Gas	1-46

TURBOCHARGER

Application	2-110
Description	2-110
Internal Inspection	2-113
Operation	2-110
Removal & Installation	2-113
Testing	2-112

V

VALVE

Clearance	
4-Cylinder Gas	1-37
V6 Gas	1-41
V8 Diesel	1-52
V8 Gas	1-46

VEHICLE IDENTIFICATION NUMBER

4-Cylinder Gas	1-37
V6 Gas	1-41
V8 Diesel	1-52
V8 Gas	1-46
VIN Code Explanation	G-3

W

WIRE RESISTANCE

4-Cylinder Gas	1-37
V6 Gas	1-41
V8 Gas	1-46

Section G

**GENERAL
INFORMATION**

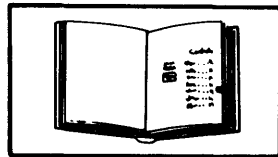

CONTENTS

	Page
Maintenance Reminder Lights	G-2
VIN Code Explanation	G-3
Tool Applications	G-4

NOTE: ALSO SEE GENERAL INDEX

Maintenance Reminder Lights

1981 RESET PROCEDURES DOMESTIC CARS

AMERICAN MOTORS

Every 30,000 miles, an emission maintenance reminder light appears on instrument panel indicating Emission service and replacement of oxygen sensor is required. Reset light activating switch as follows:

In engine compartment, locate switch between upper and lower speedometer cables next to firewall. Slide rubber boot up and, with small screw driver, turn reset screw clockwise 1/4 turn until detent resets in switch.

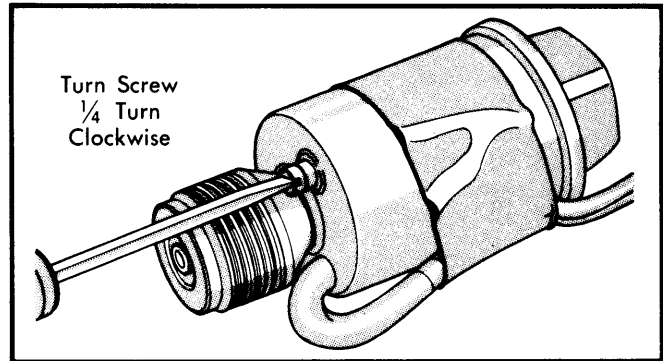

Fig. 1 Resetting Maintenance Reminder Switch American Motors

CHRYSLER CORP.

NOTE — Chrysler Corp. does not use a maintenance reminder for 1981.

FORD MOTOR CO.

NOTE — Ford Motor Co. does not use a maintenance reminder for 1981.

GENERAL MOTORS

Chevette (Gasoline Engines Only) — Every 30,000 miles a maintenance reminder "flag" appears in speedometer face, indicating replacement of oxygen sensor is necessary.

Reset Procedure — Remove instrument panel trim plate. Remove instrument cluster lens. Using pointed tool, apply light downward pressure on notches of flag until it is reset. An alignment mark will appear in left center of odometer window when flag is fully reset.

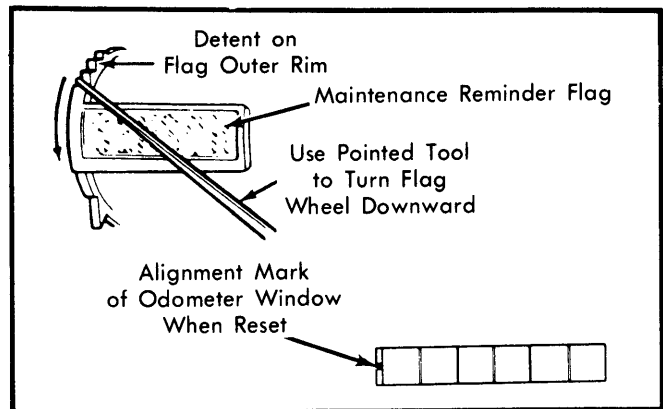

Fig. 2 General Motors Maintenance Reminder Flag Resetting Procedure

VIN Code Explanation

ALL MANUFACTURERS

1 G 1 A Z 3 7 A X E 5 1 0 0 0 0 1

① ② ③ ④ ⑤ ⑥ ⑦ ⑧ ⑨ ⑩ ⑪ ⑫ ⑬ ⑭ ⑮ ⑯ ⑰

- ① - Indicates Nation of Origin.
- ② - Indicates Manufacturer.
- ③ - Indicates Make and Type.
- ④ - Indicates Restraint System (Engine Type for AMC)
- ⑤ - Indicates Carline/Series. (Transmission/Transaxle/Transfer Case for AMC)
- ⑥ ⑦ - Indicates Body Types
- ⑧ - Indicates Engine Type and Make (Restraint System for AMC).
- ⑨ - Indicates Check Digit.
- ⑩ - Indicates Model Year.
- ⑪ - Indicates Assembly Plant.
- ⑫ ⑬ ⑭ ⑮ ⑯ ⑰ - Indicates Plant Sequential Number.

AMERICAN MOTORS VIN ENGINE CODES

Code Digit	Engine
B	2.5L (151") 2-Bbl. 4-Cyl.
C	4.2L (258") 2-Bbl. 6-Cyl.

CHRYSLER CORP. VIN ENGINE CODES

Code Digit	Engine
A	1.7L (105") 2-Bbl. 4-Cyl.
C	2.2L (135") 2-Bbl. 4-Cyl.
D	2.6L (156") 2-Bbl. 4-Cyl.
E	3.7L (225") 1-Bbl. 6-Cyl.
J	5.2L (318") EFI V8
K	5.2L (318") 2-Bbl. V8
M	5.2L (318") 4-Bbl. V8

FORD MOTOR CO. VIN ENGINE CODES

Code Digit	Engine
A	2.3L (140") 2-Bbl. 4-Cyl.
B	3.3L (200") 1-Bbl. 6-Cyl.
D	4.2L (255") 2-Bbl. V8
F	5.0L (302") 2-Bbl. V8
F	5.0L (302") EFI V8
G	5.8L (351") 2-Bbl. V8

GENERAL MOTORS VIN ENGINE CODES

Code Digit	Engine
9	1.6L (98") 2-Bbl. 4-Cyl.
D	1.8L (111") Diesel 4-Cyl.
G	1.8L (113") 2-Bbl. 4-Cyl.
5	2.5L (151") EFI 4-Cyl.
X	2.8L (173") 2-Bbl. V6
Z	2.8L (173") 2-Bbl. V6
A	3.8L (231") 2-Bbl. V6
K	3.8L (229") 2-Bbl. V6
3	3.8L (229") Turbo 4-Bbl. V6
4	4.1L (252") 4-Bbl. V6
F	4.3L (260") 2-Bbl. V8
S	4.3L (265") 2-Bbl. V8
J	4.4L (267") 2-Bbl. V8
T	4.9L (301") Turbo 4-Bbl. V8
W	4.9L (301") 4-Bbl. V8
H	5.0L (305") 4-Bbl. V8
Y	5.0L (307") 4-Bbl. V8
L	5.7L (350") 4-Bbl. V8
6	5.7L (350") 4-Bbl. V8
N	5.7L Diesel V8
9	6.0L EFI V8-6-4

Tool Applications

ALL MANUFACTURERS

DESCRIPTION

Tool applications used in this manual are noted in the text of all articles where applicable. These tools are usually specific tools that must be used to perform a specific function in Removal, Installation, Overhaul or Testing of a component.

For example; "Using Spline Adapter (J-28513) and Holding Wrench (J-28514), tighten pinion nut until end play is taken up." Although other tools could possibly be substituted, the tool references are those that are recommended by the vehicle manufacturer. These tools should be used whenever possible. Normally, in cases where a non-specific tool is called for, no tool number will be given.

For example; "Place bearing insert in rod and install guides on rod bolts. Compress piston rings using ring compressor." Since about any ring compressor that works and does not damage the components can be used, normally no specific tool number will be called out.

The following descriptions show an example of the reference in text, the maker of the tools recommended by the manufacturer and the tool maker's address. Further information on tools and local suppliers of the tools can be obtained from the tool maker. It is also possible, for example, that a Kent-Moore tool may be cross-referenced to another tool maker. In this case it is imperative that the tools be exactly the same in design, or the specific function of the tool may not be able to be performed.

AMERICAN MOTORS

American Motors Eagle tool applications called out in this manual will appear as follows: "Use Bearing Remover (J-21473-1) and Extension (J-21054-1) to drive out bearing." The "J" in front of the first set of numbers means that it is a Kent-Moore tool. The second set of numbers is the basic tool part number. Part numbers with no additional characters after the basic part number means that the tool listed is a complete tool. The last number means that it is either part of a set (-2,-3 etc.), or a revised tool number (-02,-03, or -B,-C etc.).

AMC TOOL MANUFACTURER

Kent-Moore Tool Division
29784 Little Mack
Roseville, Mich., 48066-2298
Telephone (313) 774-9500
Telex 23-5377

American Motors/Renault tool applications called out in this manual will appear as follows: "Install Spring Retainer (Sus.594-02). Adjust rocker arms using Adjuster (Mot.567)." The two or three letter code at the front of the number stands for the mechanical application, such as Mot. = Motor and Sus. = Suspension. The three digit number after the letters is the tool part number abbreviation. Renault tool numbers are actually listed as 00 00 047 600. The 476 is used for the tool abbreviation as shown in this manual. Any numbers after the three digit part number mean that there is more than one part to the tool.

RENAULT TOOL MANUFACTURER

Facom Tools Inc.
2177-0 Flintstone Dr.
Tucker, (Atlanta) Ga. 30084

CHRYSLER CORP.

Chrysler Corp. tool applications called out in this manual will appear as follows: "Assemble Pinion Locating Spacer (SP-6030) over body of main tool (SP-5385). Install Shaft Locating Sleeve (L-4507), Washer (C-4656) and Compression Nut (SP-533)."

The prefixes "C," "L" and "SP" mean that the tools are manufactured by Miller Special Tools. The number after the letter prefix is the basic tool part number. Any letters or numbers after the basic part number designate either a revised tool number or that the tool is part of a set.

CHRYSLER CORP. TOOL MANUFACTURER

Miller Special Tools
Division of Utica Tool Co., Inc.
32615 Park Lane
Garden City, Mich. 48135
Telephone (313) 522-6717

FORD MOTOR CO.

Ford Motor Co. tool applications called out in this manual will appear as follows: "Remove pinion bearing with Slide Hammer (T50T-100A with Attachment T58L-101-A). Remove bearing with Puller (T81P-3504-S, T58L-101-A and T81P-3504-T)."

Ford Motor Co. tools are manufactured by Owatonna Tools. The prefix used with Ford tool numbers means that the tools are essential tools. The number after the prefix is the basic tool part number. Any letters or numbers after the basic part number designate either a revised tool number or that the tool is part of a set.

FORD MOTOR CO. TOOL MANUFACTURER

Owatonna Tool Co. Inc.
Owatonna, Minn. 55060
Telephone (507) 455-2626
Telex 29-0876

GENERAL MOTORS

General Motors tool applications called out in this manual will appear as follows: "Install Pivot Pin Remover (J-21854-1) and remove pins. Using Pin Punch (J-22635), drive out lever pin."

The "J" in front of the first set of numbers means that it is a Kent-Moore tool. The second set of numbers is the basic tool part number. Part numbers with no additional characters after the basic part number means that the tool listed is a complete tool. The last number means that it is either part of a set (-2,-3 etc.), or a revised tool number (-02,-03, or -B,-C etc.).

GENERAL MOTORS TOOL MANUFACTURER

Kent-Moore Tool Division
29784 Little Mack
Roseville, Mich., 48066-2298
Telephone (313) 774-9500
Telex 23-5377