

# 9-58 4-Wheel Drive Steering Knuckles

## ALL MANUFACTURERS

### DESCRIPTION

Open type steering knuckles are used on all models. Open type knuckles provide a sharper turning angle, which will decrease the vehicle turning radius.

All of the vehicle weight is carried by the axle housing and steering knuckle. The axle shafts are free floating. Depending upon vehicle model, the steering knuckles can be attached to the axle housing by either ball joints or roller bearings and pivot pins.

Other than the unique components required for front-wheel drive, all steering knuckles used on light duty trucks are mechanically identical.

### OVERHAUL

#### BALL JOINT TYPE

##### Disassembly

1) Raise vehicle, and support on safety stands. Remove wheel and tire assembly. Remove brake caliper. If equipped with locking hubs, see removal and installation instructions in appropriate Locking Hubs article in this Section.

2) Remove hub lock mechanism. Remove snap ring. Pry out driving hub and spring. Remove wheel bearing lock nut. Outer wheel bearing and retainer will come off with hub. Using a brass drift punch, remove inner bearing, cone, and seal from hub.

3) Remove inner and outer bearing cups (if necessary) using a brass punch. Remove spindle. Carefully pull axle shaft assembly through hole in steering knuckle. Press ball sockets from knuckle.

4) Remove threaded sleeve from yoke. Clean all components with solvent and blow them dry with compressed air. Inspect all parts for burrs, chips, wear, flat spots or cracks. Replace all damaged parts and parts showing excessive wear.

##### Reassembly

1) Place new lower ball socket into position on knuckle. Lower socket has shorter shaft and no cotter pin hole. Using an adapter, press into place in bore.

2) Check bore to socket clearance; it must be less than .0015" (.038 mm). Install snap ring (if equipped). Install upper socket into knuckle. Check clearance as with lower socket.

3) Install threaded sleeve into axle end yoke. Adjust threaded sleeve so that approximately 2 threads are exposed above top of yoke. Assemble knuckle to yoke. Install new nut on bottom ball joint and tighten to specifications.

4) Tighten threaded sleeve to specifications (this loads ball joints correctly). Install ball joint upper nut, and tighten to specifications. To complete reassembly, reverse disassembly procedure.

**NOTE:** When aligning upper ball joint nut to install cotter pin, always tighten nut to align. Never loosen nut to align holes.

#### KING PIN TYPE

##### Disassembly

1) Raise vehicle, and support on safety stands. Remove wheel and tire assembly. Remove brake caliper. If equipped with locking hubs, see removal and installation instructions in appropriate Locking Hubs article in this Section.

2) Remove hub lock mechanism. Remove snap ring. Pry out driving hub and spring. Remove wheel bearing lock nut. Outer wheel bearing and retainer will come off with hub.

3) Using a brass drift punch, remove inner bearing, cone, and seal from hub. Remove inner and outer bearing cups (if necessary) using a brass punch. Remove spindle. Carefully pull axle shaft assembly through hole in steering knuckle.

Fig. 1: Exploded View of Ball Joint Type Steering Knuckle Assembly

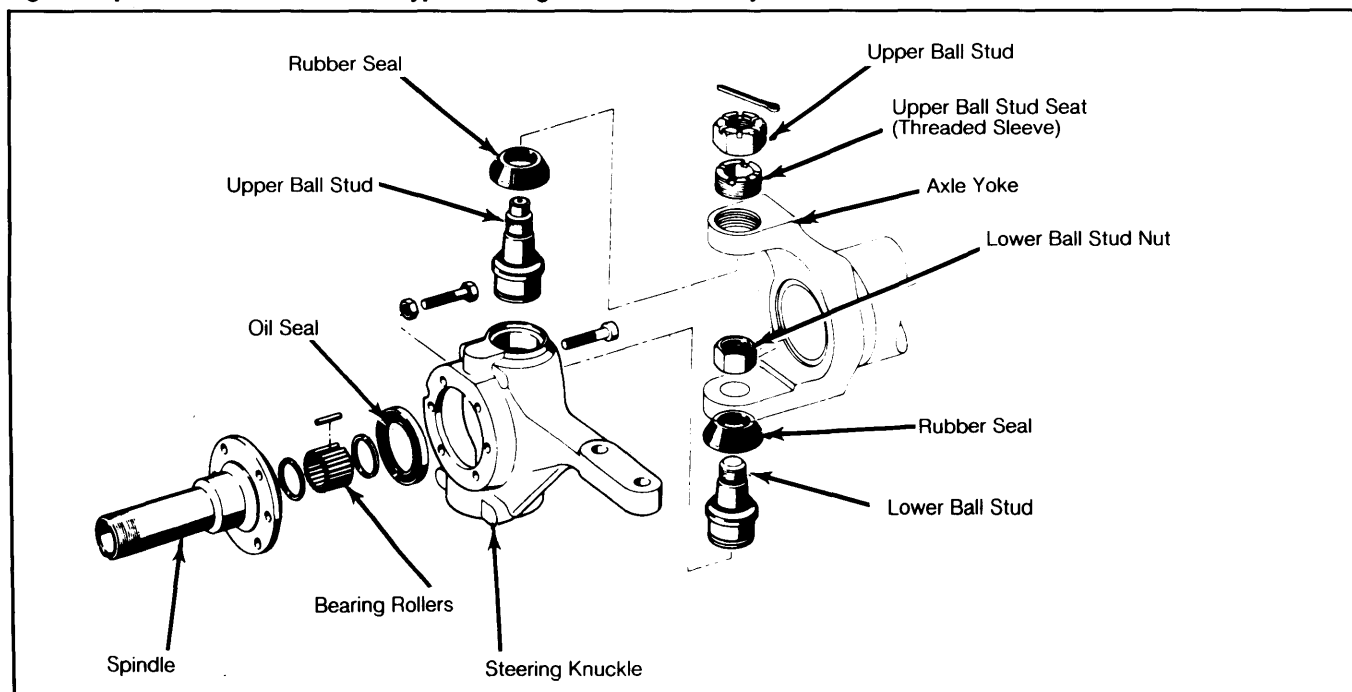

# 4-Wheel Drive Steering Knuckles

## ALL MANUFACTURERS (Cont.)

**Fig. 2: Sectional View of Ball Joint Type Steering Knuckle Assembly**

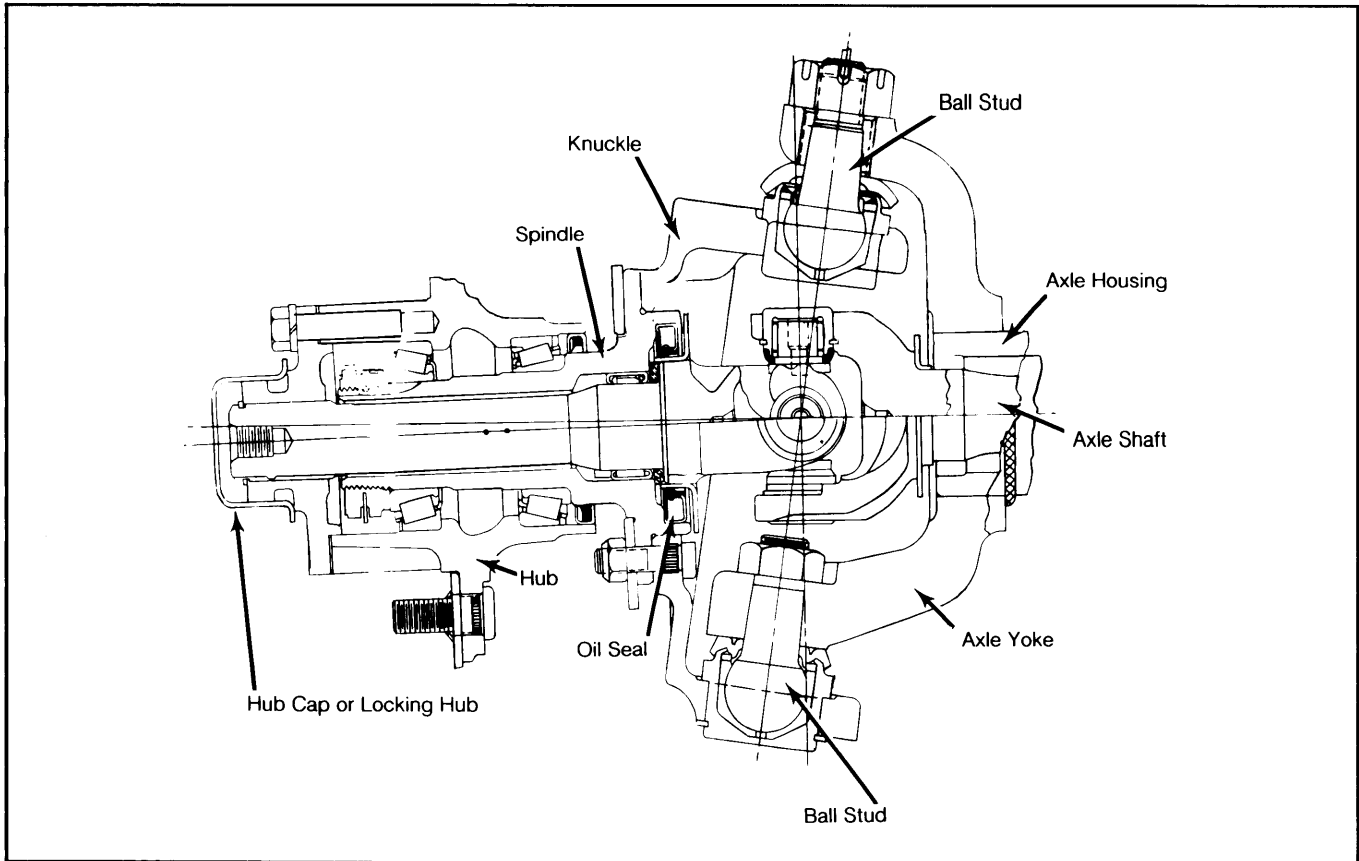

**Fig. 3: Sectional View of King Pin Type Steering Knuckle Assembly**

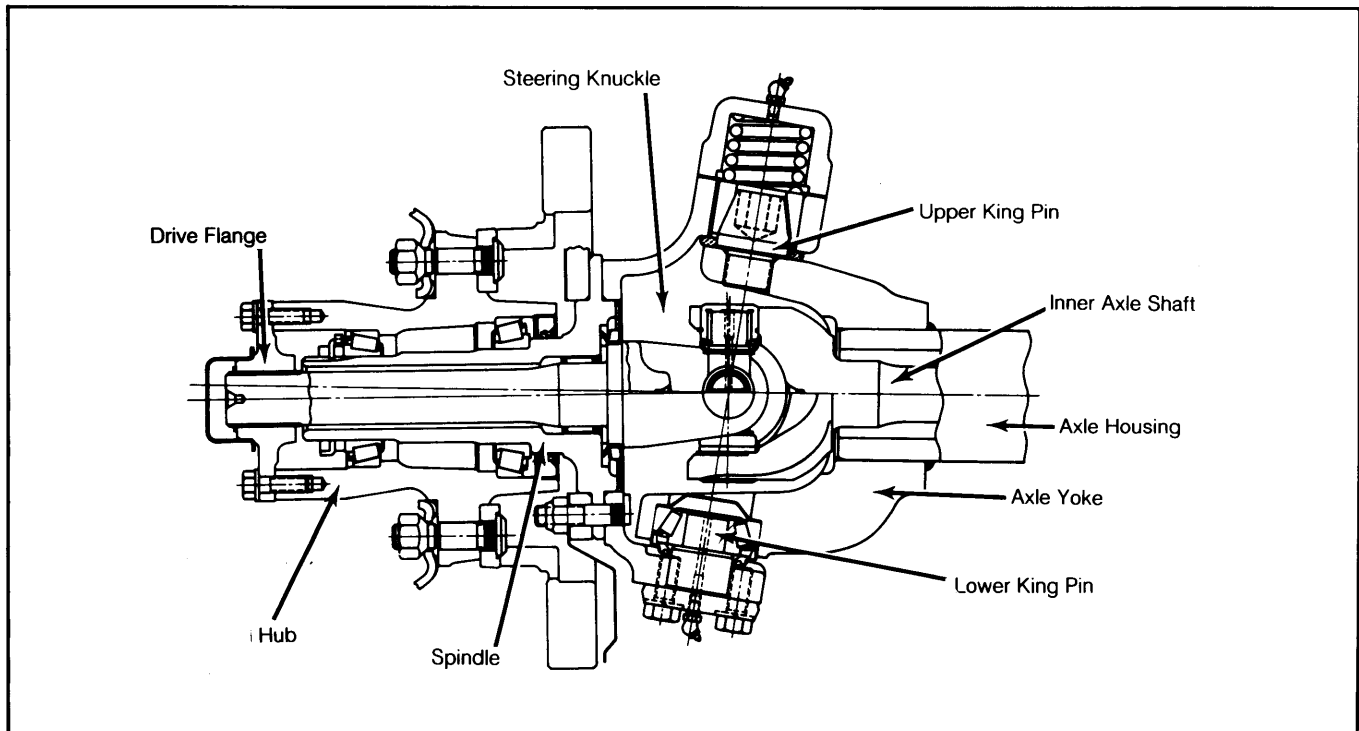

# 4-Wheel Drive Steering Knuckles

## ALL MANUFACTURERS (Cont.)

4) Disconnect steering linkage at knuckle. Remove nuts from upper king pin cap. Remove nuts alternately as spring will force cap up. Remove cap, compression spring, and gasket.

5) Remove nuts from lower cap. Remove cap and king pin. Remove upper king pin tapered bushing and knuckle from axle yoke. Remove upper king pin from yoke using puller.

6) Using a punch, drive out lower king pin bearing cup, cone, grease retainer, and seal. Drive out from top to bottom.

### Reassembly

1) Install a new grease retainer and bearing cup in bottom of yoke. Fill grease retainer with lubricant. Grease bearing cone, and install in cup. Install a new lower king pin oil seal.

2) Care must be taken not to distort seal as it is driven into place. It will protrude slightly from surface of yoke. Using socket, install upper king pin. Installation torque is 500-600 ft. lbs. (680-816 N.m).

3) Position felt seal on king pin. Install steering knuckle and tapered bushing on king pin. Install lower bearing cap and king pin. Tighten bolts alternately and evenly to specifications.

4) Install compression spring on upper king pin bushing. Install bearing cap using a new gasket. Tighten nuts alternately and evenly to specifications.

loosen lock nut on turning angle stop screw. Using a turntable to measure angle, adjust stop screw to obtain specified angle. Tighten lock nut without changing setting.

### TIGHTENING SPECIFICATIONS

Application	Ft. Lbs. (N.m)
<b>Ball Joint Type</b>	
<b>Threaded Sleeve (Upper Ball Stud Seat)</b>	
Ford & Chrysler Corp. ....	40 (54)
All Others .....	50 (68)
<b>Upper Ball Joint Nut</b>	
Chrysler Corp. ....	135 (184)
All Others .....	100 (136)
<b>Lower Ball Joint Nut</b>	
Chrysler Corp. ....	135 (184)
All Others .....	80 (109)
<b>King Pin Type</b>	
King Pin Cap Bolts .....	70-90 (95-122)
Drag Link-to-Steering Knuckle .....	60 (82)
Tie Rod-to-Steering Knuckle .....	45 (61)

## ADJUSTMENT

### BALL JOINTS

1) Raise vehicle, and position on safety stands. Disconnect tie-rod at steering knuckle. Connect a spring tension gauge to tie-rod hole in steering knuckle. Place steering knuckle in straight ahead position.

2) Measure force required to pull steering knuckle to the right after initial breakaway. The pull should not exceed 25 ft. lbs. (34 N.m). If pull required exceeds 25 ft. lbs. (34 N.m), remove upper ball joint stud nut, and loosen adjusting sleeve as required.

### TURNING ANGLE

Turning angle stop screws are located at rear of steering knuckle, just above axle centerline. To adjust,

### TURNING ANGLE ADJUSTMENT

Application	Left Wheel	Right Wheel
<b>Chrysler Corp.</b>		
W150 .....	37°	27°
W250 .....	35°	<sup>1</sup> 29°
W350/450 .....	34°	29°
D150/450 .....	33°	33°
<b>Ford</b>		
F150 & Bronco .....	36°	36°
F250 .....	33.4°	33.4°
F350 .....	30.3°	30.3°
<b>Jeep</b>		
"CJ" & Scrambler .....	31-32°	31-32°
All Others .....	37-38°	37-38°

<sup>1</sup> - If equipped with 8.75 x 16.5 tires, turning angle is 26°. If equipped with 9.50 x 16.5 tires, turning angle is 24°.