

JEEP 8⁷/₈" RING GEAR

Cherokee, CJ, J10,
Scrambler, Wagoneer; Rear Axle

DESCRIPTION

The Jeep 8⁷/₈" ring gear axle assembly is a hypoid gear type with integral carrier housing. This semi-floating axle is used as the rear drive axle on CJ, Scrambler, Cherokee, J10 and Wagoneer models.

The axle is equipped with tapered axle shafts on CJ and Scrambler models, and with flanged axle shafts on Cherokee, J10 and Wagoneer models.

Pinion bearing preload is adjusted by varying shim thickness. A removable housing cover allows access to differential for inspection or minor servicing, without removing axle assembly.

AXLE RATIO & IDENTIFICATION

This Jeep axle assembly has a 10 bolt cover. Some Jeep models use a Spicer (Dana) axle. Refer to Spicer (Dana) Semi-Floating or Full-Floating articles in this section, for correct identification. To determine drive axle ratio, refer to Drive Axle Ratio Identification article in this section.

REMOVAL & INSTALLATION

AXLE HUB

Removal (CJ & Scrambler Models)

1) Remove dust cap, nut and washer. Raise vehicle and remove tire and wheel. Remove brake drum retaining screws, and remove drum. Using puller (J-25109-01), remove hub.

2) Inspect hub for loose or damaged wheel studs. Check keyway and tapered center bore for wear or cracks. Replace hub if necessary.

CAUTION: Do not use a knockout or slide hammer-type puller to remove hub. This type of puller may damage axle assembly.

Installation of Original Hub (CJ & Scrambler Models)

1) Align axle key and hub keyway. Slide hub onto axle shaft as far as possible. Install nut and washer. Install drum retaining screws, wheel and tire.

2) Lower vehicle and tighten nut to 250 ft. lbs. (340 N.m). Tighten nut to align cotter key hole, do not back nut off.

NOTE: Installation procedures for a new hub and an old hub will differ. If axle shaft is replaced, hub must also be replaced, however, a new hub can be installed on an old axle shaft.

Installation of New Hub (CJ & Scrambler Models)

1) Align axle key and hub keyway. Slide hub onto axle shaft as far as possible. Install 2 lubricated thrust washers and axle shaft nut. Install drum retaining screws, wheel and tire. Lower vehicle. See Fig. 1.

2) Tighten axle shaft nut until distance from outer hub face to end of axle is 1⁵/₁₆". Pressing hub on to

this dimension is necessary to form hub serrations correctly.

3) Remove axle shaft nut and 1 washer. Install nut, and tighten to 250 ft. lbs. (340 N.m). Tighten nut to align cotter key hole. Do not back off nut.

Fig. 1: Jeep Hub Installation Measurement

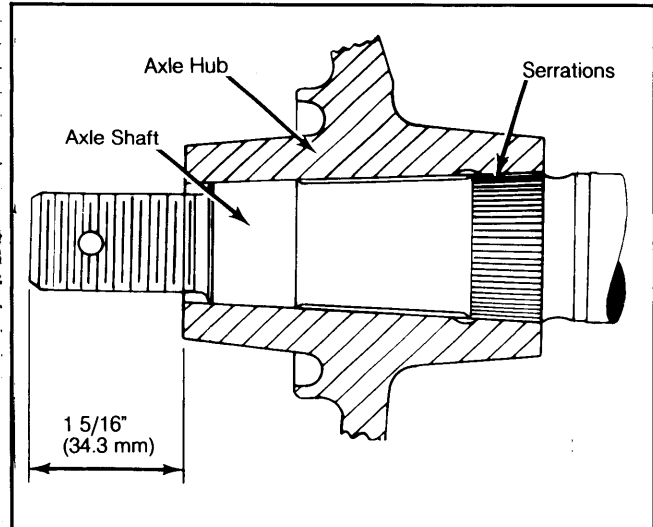

Tighten axle shaft nut until distance from outer hub face to end of axle is corrected.

AXLE SHAFTS & BEARINGS

Removal (CJ & Scrambler Models)

1) Remove axle hub as previously outlined. Disconnect parking brake cable at equalizer, and brake line at wheel cylinder. Remove backing plate, oil seal, and shims from axle shaft.

2) Using puller (J-2498), remove axle shaft. Remove and discard inner seal. Bearing cone is press fit on axle shaft, and must be removed using an arbor press and mandrel.

Installation (CJ & Scrambler Models)

1) Press new axle bearing onto shaft, with small diameter of cone towards outer end of shaft. Coat inner axle shaft seal with a light coat of oil. Coat outer surface of metal retainer with non-hardening sealer.

NOTE: Tapered axle shaft bearings have no provision for lubrication, and should be packed with a good wheel bearing lubricant before installation.

2) Install inner seal in axle housing using an installer (J-21788). Place axle shaft in housing, and align splined end with differential gears. Install outer bearing cup. Coat backing plate with sealer at mounting area.

3) Install original shims, oil seal assembly, and backing plate. Tighten backing plate bolts to 35 ft. lbs. (47 N.m). Oil seal and retainer are located on outside of backing plate.

4) If left axle was removed, end play must be adjusted. To adjust end play, remove left axle hub, if not previously removed. Strike ends of both axles with a lead hammer to seat bearings.

5) Attach axle shaft end play tool (J-2092) and a dial indicator to left axle. Move axles back and forth to

Drive Axles

JEEP 8⁷/₈" RING GEAR (Cont.)

measure end play. End play should be .004 -.008" (.10-.20 mm) with .006" (.15 mm) recommended.

6) Add shims to increase end play; remove shims to decrease end play. Install hub and drum, as previously outlined. Adjust brakes, and bleed brake hydraulic system.

Fig. 2: Removing Bearing Retaining Ring from Cherokee, J-10 & Wagoneer Models

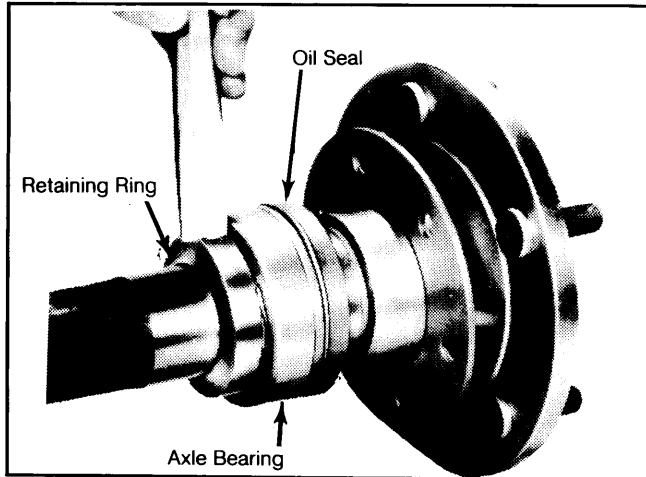

Drill retaining ring part way through, and cut with chisel.

Removal (All Other Models)

1) Raise and support vehicle, and remove rear wheels. Remove brake drum. Remove nuts and lock washers attaching support plate and retainer to axle tube flange.

2) Install slide hammer and adapter tool (J-2619-01 & J-21579) on axle flange, and remove axle shaft. Remove and discard oil seal from axle housing, and wipe seal bore in housing clean.

3) Mount axle shaft in vise. Drill a 1/4" hole in retaining ring approximately 3/4 way through ring thickness, making sure not to let drill contact axle shaft. See Fig. 2.

4) Position chisel over drilled hole in retaining ring and cut ring. Remove it from axle shaft. Cut through oil seal using hacksaw and remove seal and retainer plate, making sure not to damage seal contact surface.

5) Remove axle shaft bearing using arbor press and mandrels.

CAUTION: Do not use a torch to remove axle shaft retaining ring or bearing.

Installation (All Other Models)

1) Install retainer plate on axle shaft. Pack wheel bearing lubricant in oil seal cavity and between oil seal lips. Install seal on axle shaft with outer face of seal facing axle flange.

2) Pack new axle bearing with wheel bearing lubricant. Install bearing on axle shaft, making sure bearing cup rib ring is facing axle flange.

3) Install bearing retainer ring. Press axle shaft bearing and retaining ring on axle shaft simultaneously. Make sure both are seated properly against axle shaft shoulder.

4) Install new oil seal in axle housing using an installer (J-21788). Install axle shaft through support plate.

Coat outside diameter of bearing cup with wheel bearing lubricant before installing in bearing bore.

5) Tap flanged end of axle shaft lightly, using soft mallet to position axle shaft bearing in bearing bore of housing. Install axle shaft retainer and brake support plate to axle tube flange.

6) Install attaching lock washers and nuts. Tighten to 35 ft. lbs. (47 N.m). Install brake drums and rear wheels. Lower vehicle.

PINION FLANGE & SEAL

Removal

1) Raise and support vehicle. Remove both rear wheels and brake drums. Disconnect propeller shaft from flange. Mark propeller shaft position with flange. Connect an INCH Lb. torque wrench to flange nut. Rotate several times, and measure torque required to turn pinion.

2) Record reading for assembly. Hold flange and remove nut. Mark position of flange on drive pinion. Discard pinion nut. Using a puller, remove flange. If surface is damaged or grooved, replace flange. Pry out old seal and discard.

Installation

1) Coat seal lip with axle lubricant before installing. Install seal using installer (J-22661). Align drive pinion shaft and flange marks, and install flange on drive pinion.

2) Tighten replacement nut only enough to remove end play. Check torque required to turn drive pinion. Refer to reading recorded during flange removal.

3) Tighten nut enough to exceed recorded reading by 5 INCH Lbs. (.6 N.m). Repeat these steps until desired torque is obtained. Install propeller shaft aligning marks. Install brake drums and wheels.

CAUTION: Do not loosen and retighten nut. Do not over-tighten nut. If correct torque is exceeded, a new collapsible spacer must be installed, and drive pinion preload must be reset.

AXLE ASSEMBLY

Removal

1) Raise and support vehicle forward of rear springs. Remove wheels with tires. Mark propeller shaft position with flange, and disconnect propeller shaft. Disconnect shock absorbers and brake line at "T" fitting.

2) Plug open ends of lines to prevent dirt from entering system. Disconnect parking brake cable at equalizer. Support axle housing with a floor jack. Remove "U" bolts at spring.

3) If vehicle has springs mounted below axles, disconnect shackle bolts and lower spring from axle. Slide axle housing out from under vehicle.

Installation

To install axle assembly, reverse removal procedure. Bleed brake hydraulic system and check axle lubricant level.

OVERHAUL

DISASSEMBLY

NOTE: It is not necessary to remove complete axle assembly from vehicle for overhaul.

JEEP 8⁷/₈" RING GEAR (Cont.)

1) Remove axle shaft dust caps and retaining nuts. Raise and support vehicle. Remove axle housing cover, and drain lubricant. Remove axle hubs as previously outlined. Mark differential side bearing caps with a center punch for reassembly.

2) Loosen bearing cap bolts, until they are retained by just a few threads. This will prevent differential from falling out. Pry differential loose in housing. Remove bearing caps and differential.

3) Secure bearing shims to their respective bearing caps and cups. See Fig. 3. Use puller (J-2497-01) to remove side bearings from differential. Make sure puller pulls against bearing cone and not bearing cage or rollers.

4) Remove ring gear retaining bolts, and tap ring gear off differential using a brass hammer. Drive out pinion shaft lock pin, using a $\frac{3}{16}$ " drift punch. Drive out pinion shaft using a punch. With shaft removed, withdraw thrust block.

5) Roll pinion gears around on side gears until they can be removed. Remove side gears and thrust washers. See Fig. 4. With propeller shaft removed, hold flange and remove retaining nut. Remove flange using a puller.

6) Install housing cover with 2 bolts. Remove pinion seal. Strike end of drive pinion with a soft mallet. This will unseat front bearing cone from gear. Remove bearing cone. Remove and discard collapsible spacer. Remove housing cover, drive pinion, and rear bearing.

7) Remove front and rear bearing cups using a slide hammer and adapter. Pinion depth shims are behind rear bearing cone. Secure shims to cone for reassembly reference.

Fig. 4: Removal of Jeep Pinion Shaft Lock Pin

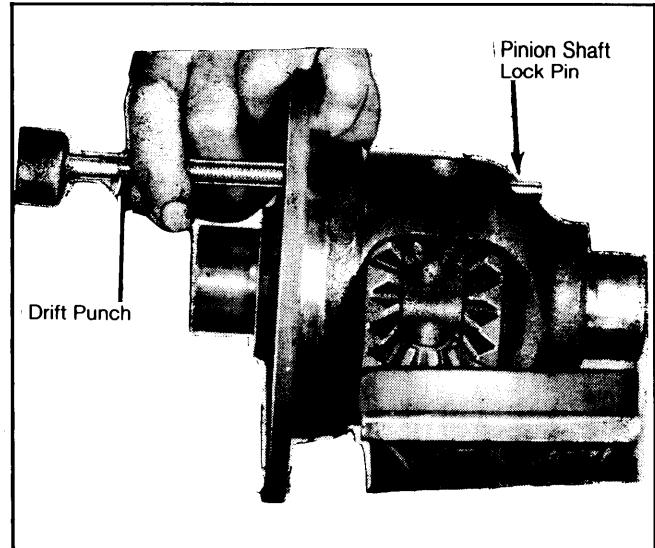

With shaft removed, withdraw thrust block.

Fig. 3: Exploded View of CJ & Scrambler Drive Axle Assembly

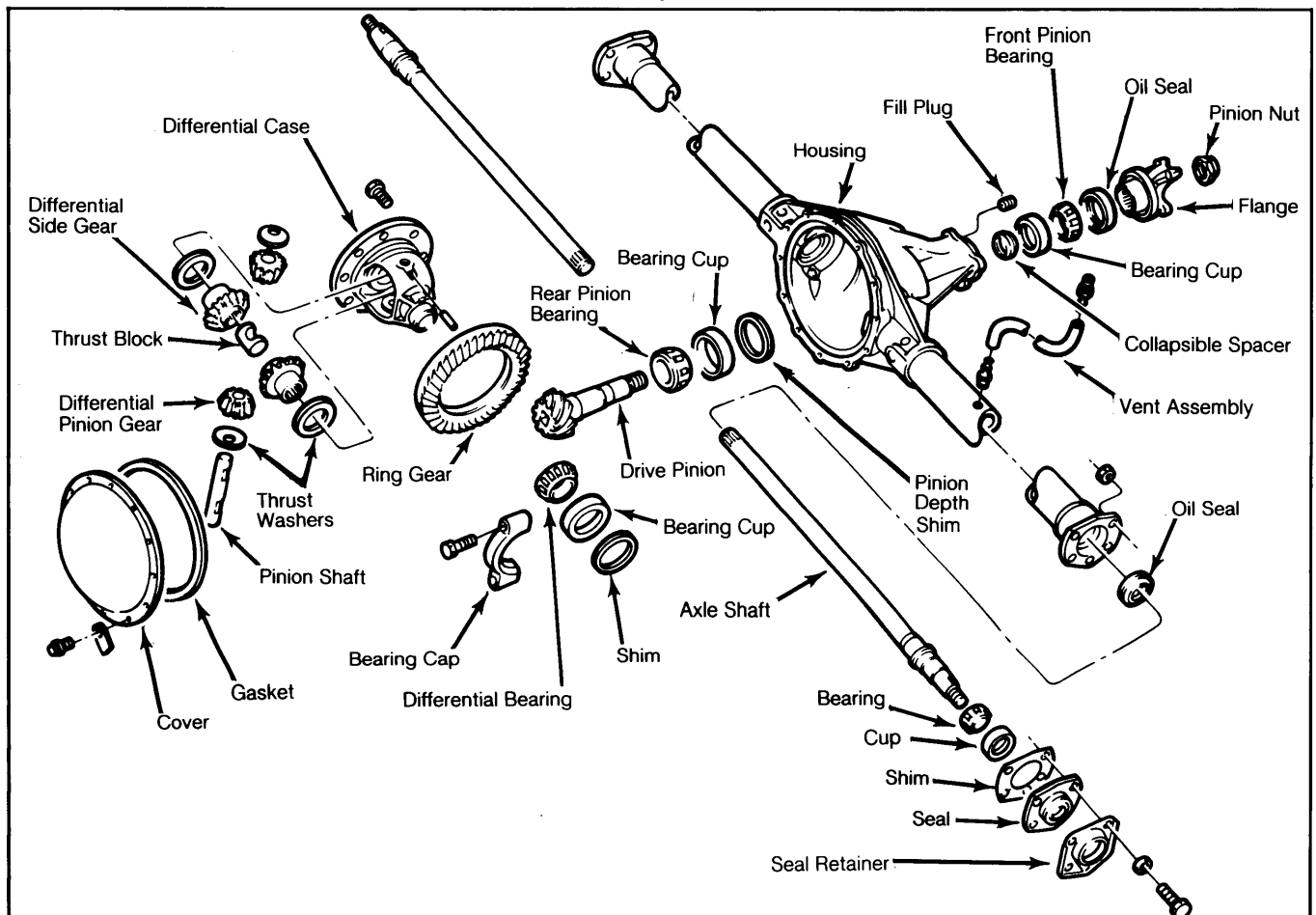

Drive Axles

JEEP 8⁷/₈" RING GEAR (Cont.)

CLEANING & INSPECTION

Clean all components in solvent. Allow bearings to air dry. Inspect all machined surfaces for smoothness or raised edges. Inspect all bearings and cups for wear or pitting and replace as necessary. Inspect all gear teeth for wear or chipping and replace as necessary.

REASSEMBLY & ADJUSTMENT

Drive Pinion Installation & Depth Adjustment

1) Pinion gear depth is distance from end face of pinion to the axle shaft centerline. This dimension is controlled by shims installed between pinion gear bearing and axle housing. See Fig. 5.

2) There are 2 numbers painted on pinion gear and 1 number painted on ring gear. The first number on pinion gear and number on ring gear identify both as a matched set.

NOTE: Ring and pinion gears should not be used if numbers do not match, or if replacement gear sets are marked .009" or more.

Fig. 5: Standard Setting Dimension & Pinion Depth Shim Location

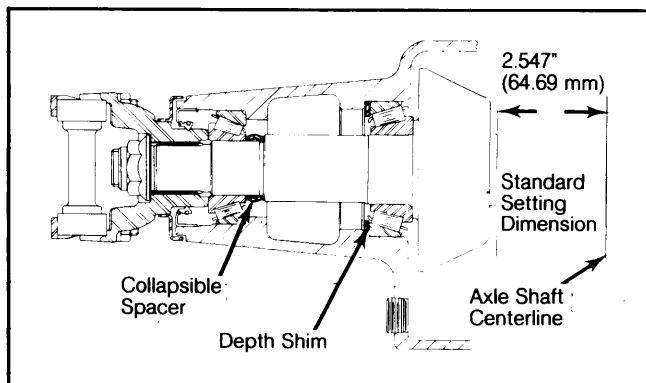

Pinion gear depth is the distance from end face of pinion to the axle shaft centerline.

3) Second number on pinion gear represents pinion depth variance. This indicates (in thousandths of an inch) the amount that the ring and pinion gear varied from standard setting to obtain the correct gear tooth contact pattern.

EXAMPLE:

- Standard pinion depth is 2.547" (64.69 mm). If pinion gear is marked "2", the set varied from the standard setting by .002" (.05 mm). This means that .002" (.05 mm) less shim will be required than for a gear set marked "0".
- Some factory-installed sets may have .010" (.25 mm) or .020" (.51 mm) machined off the pinion gear end face. Identifying numbers will appear differently.

Example:

- If gear is machined .010" (.25 mm), the identifying number will appear as +16. The "1" indicates that .010" (.25 mm) was removed from end face; and the "6" indicates that pinion depth variance is .006" (.15 mm). A gear machined .020" (.51 mm) would be identified in the same manner, only a "2" will be used rather than a "1". The marking would then be +26.

4) To determine a starting shim thickness to measure pinion depth and determine the correct shim thickness, measure thickness of shim removed during disassembly. Note pinion depth variance on old and new pinion gears.

5) Using Pinion Depth Variance Chart, determine amount to be added or subtracted from original shim thickness to determine starting shim thickness.

EXAMPLE:

- If the old pinion is marked -3 and the new pinion is marked +2, the chart indicates -.005". This means that .005" (.13 mm) would be reduced from original shim thickness to determine starting shim.

NOTE: Do not use starting shim thickness as final shim thickness.

6) Install rear bearing on pinion gear. Make sure large diameter of bearing cage faces gear end of pinion. Make sure bearing is fully pressed against rear face of gear.

7) Make sure pinion gear bearing bores in housings are clean. Install shim in rear bearing cup bore. If shim is chamfered, make sure chamfered side faces bottom of bore.

8) Install front and rear bearing cups, using mandrels and drivers. Install pinion gear in position in housing.

9) Install front bearing, rear universal joint yoke, and original pinion nut. Tighten pinion nut only enough to remove all end play.

NOTE: Do not install new pinion nut or collapsible spacer at this time. These will be installed when pinion bearing preload is adjusted.

10) Note pinion depth variance marked on pinion gear. Add or subtract this from standard pinion depth. This is correct pinion depth. Record this figure.

11) Assemble pinion depth measuring gauge arbor tool (J-5223-4) and centering discs (J-5223-23). With discs fully seated, install gauge assembly in differential bearing cup bores. Install bearing caps, and tighten bolts securely.

12) Position gauge block (J-5223-20) on end face of pinion. Make sure anvil end of gauge block is seated on gear, and that gauge block plunger is under arbor tool.

13) Attach gauge block clamp (J-5223-14) and bolt (J-5223-24) to housing cover bolt. Tighten clamp bolt down against gauge block to prevent block from moving. See Fig. 6.

14) Loosen gauge block thumb screws, and allow gauge block plunger to contact arbor tool. Now tighten thumb screw securing plunger in position. Remove clamp and then gauge block.

15) Using a 2 to 3-inch micrometer, measure distance from end of anvil on gauge block to end of plunger. This represents measured pinion depth. Record this measurement.

16) Remove bearing caps. Remove arbor and disc assembly. Remove pinion gear, bearing cup, and depth shim from axle.

17) Measure thickness of starting shim. Add this to measurement obtained in step 15). From this total,

JEEP 8⁷/₈" RING GEAR (Cont.)

subtract desired pinion depth measurement obtained in step 10). The result is the shim thickness required to obtain correct pinion depth.

EXAMPLE:

Standard Pinion Depth 2.547" (64.69 mm)
 Pinion Depth Variance +.007" (.18 mm)
 Desired Pinion Depth =2.554" (64.87 mm)

Measured Pinion Depth 2.550" (64.77 mm)
 Starting Shim Thickness +.098" (2.49 mm)
 Total Measured Pinion Depth =2.648" (67.26 mm)

Total Measured Pinion Depth 2.648" (67.26 mm)
 Desired Pinion Depth -2.554" (64.87 mm)
 Correct Shim Thickness =.094" (2.39 mm)

Fig. 6: Measuring Pinion Depth

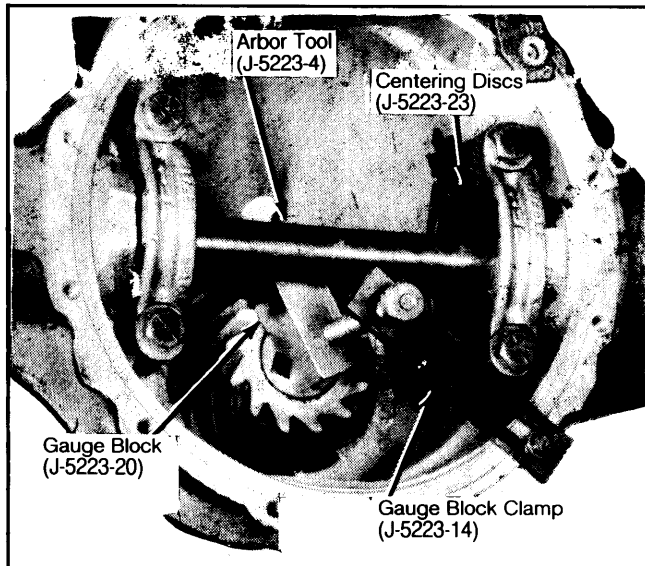

Tighten clamp down against gauge block to prevent block from moving.

Drive Pinion Bearing Preload

- 1) Install correct pinion gear depth shim(s) in housing bore. Install pinion gear and rear bearing.
- 2) Install new collapsible spacer and front bearing in housing. Install pinion oil seal using installer (J-22661). Install universal joint yoke and a new retaining nut. Tighten nut finger tight.
- 3) Now hold yoke and tighten nut. While tightening, rotate pinion to make sure bearings seat evenly.
- 4) Using an INCH Lb. torque wrench, measure torque required to turn pinion. If pinion bearing preload is not to specification, continue tightening yoke retaining nut until correct preload is obtained.

CAUTION: Do not exceed specified torque. If torque is exceeded, a new collapsible spacer must be installed, and preload must be reset. Do not loosen nut to reduce torque.

Assembling Differential Carrier

- 1) Install differential bearing onto case. Install thrust washers on differential gears (oil pocket side

toward gear). Install gears into bore in differential case. Install thrust washers behind differential pinion gears.

- 2) Mesh gears with differential gears, so holes are opposite and in line with each other. Roll gears around, until differential pinion gear holes are aligned with shaft holes in case. See Fig. 7.

Fig. 7: Installing Pinion Shaft and Thrust Block

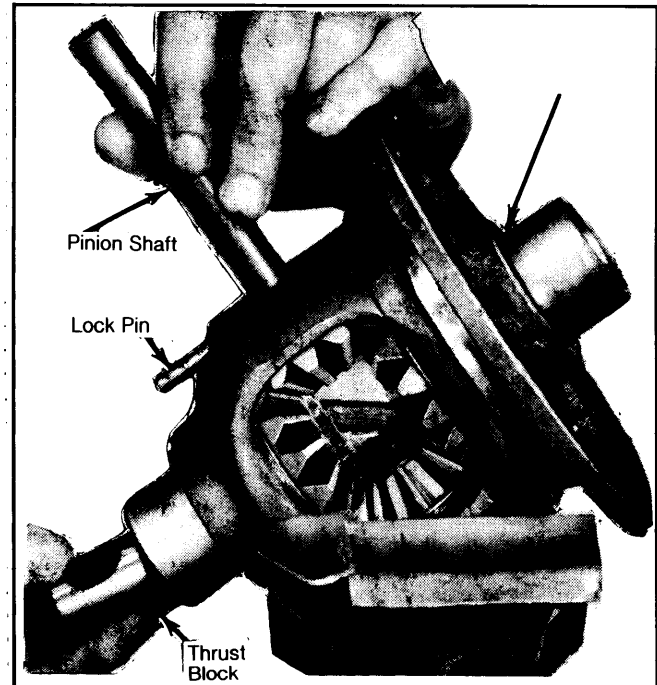

Install thrust washers behind differential pinion gears, mesh gears, and align gear and case holes

- 3) Install thrust block through a differential gear, aligning hole in block with pinion shaft holes. Install pinion shaft, with lock pin hole in shaft aligned with lock pin hole in case.

- 4) Measure any existing clearance between differential gears and case, using 2 feeler gauges on opposite sides of 1 gear. Clearance should be zero.

Adjusting Differential Bearings

- 1) Place bearing cup over each differential bearing. Install differential case assembly in axle housing. As a starting point, install an .080" (2.03 mm) shim on each side. Install bearing caps, and tighten bolts finger tight. Mount a dial indicator to housing so that plunger contacts ring gear mounting flange on differential.

- 2) Using 2 screwdrivers, pry between shims and housing. Pry assembly to one side, zero indicator. Pry assembly to opposite side and read indicator. Do not read or zero indicator while prying. The amount read on indicator is the amount of shim to be added to arrive at a no preload and no end play condition.

- 3) Shims are available in thicknesses ranging from .080" to .110" (2.03 to 2.79 mm) in .002" (.05 mm) increments. With all side play eliminated, check ring gear mounting flange for runout. Runout should not exceed .002" (.05 mm). Remove differential case from housing, and retain shims used to eliminate side play.

Ring Gear Installation

Place ring gear on differential housing case, and install retaining bolts. Two bolts installed in opposite

Drive Axles

JEEP 8⁷/₈" RING GEAR (Cont.)

holes may be used to pull ring gear into place. Tighten bolts to specifications.

Backlash Adjustment

1) Install differential assembly in housing, using shim selected to remove side play. Tighten bearing cap screws to 87 ft. lbs. (118 N.m). Attach a dial indicator to housing, so that indicator plunger contacts drive side of a tooth on ring gear and is at a right angle (90°) to it.

2) Rock ring gear, and note movement on dial indicator. Backlash should be .005-.009" (.13-.23 mm), with .008" (.20 mm) desired. To increase backlash, install a thinner shim on ring gear side. To decrease backlash, reverse procedure, however, do not change total thickness of shims.

Differential Bearing Preload

1) Differential bearings are preloaded by increasing each shim thickness by .004" (.10 mm). Install differential bearing shim in axle housing bearing bores. Assemble bearing cups on bearings (cups should completely cover rollers). Position differential so that bearings just start in axle housing bearing bores. Keep assembly square in housing and push in as far as possible.

2) Using a soft hammer, tap outer edge of bearing cups until seated in housing. Do not distort shim by hammering them into housing. Install bearing caps, aligning marks made at disassembly. Install and tighten bolts. Preloading differential bearings may change backlash setting, therefore recheck backlash and correct as necessary.

3) After all adjustments have been made, make a gear tooth pattern check to insure correct assembly. To

complete reassembly, reverse disassembly procedures. Fill rear axle with lubricant.

AXLE ASSEMBLY SPECIFICATIONS

Application	In. (mm)
Axle Shaft	
End Play004-.008 (.10-.20)
Differential Bearing	
Preload (Shims)008 (.20)
Ring Gear Backlash005-.009 (.13-.23)
Pinion Gear	
Depth (Std. Setting)	2.547 (64.69)
	INCH Lbs. (N.m)
Pinion Bearing	
Preload	17-25 (1.9-2.8)

TIGHTENING SPECIFICATIONS

Application	Ft. Lbs. (N.m)
Differential Bearing	
Cap Bolts	87 (118)
Ring Gear Bolts	105 (143)
Backing Plate Bolts	32 (44)
Rear Wheel	
Hub-to-Axle Nut	¹ 250 (340)
"U" Joint Bolt Clamp	16 (22)
¹ — CJ & Scrambler, 250 (340 N.m) Minimum.	

PINION DEPTH SHIM ADJUSTMENT CHART (INCHES)

Old Pinion Marking	New Pinion Marking								
	-4	-3	-2	-1	0	+1	+2	+3	+4
+4	+0.008	+0.007	+0.006	+0.005	+0.004	+0.003	+0.002	+0.001	0
+3	+0.007	+0.006	+0.005	+0.004	+0.003	+0.002	+0.001	0	-0.001
+2	+0.006	+0.005	+0.004	+0.003	+0.002	+0.001	0	-0.001	-0.002
+1	+0.005	+0.004	+0.003	+0.002	+0.001	0	-0.001	-0.002	-0.003
0	+0.004	+0.003	+0.002	+0.001	0	-0.001	-0.002	-0.003	-0.004
-1	+0.003	+0.002	+0.001	0	-0.001	-0.002	-0.003	-0.004	-0.005
-2	+0.002	+0.001	0	-0.001	-0.002	-0.003	-0.004	-0.005	-0.006
-3	+0.001	0	-0.001	-0.002	-0.003	-0.004	-0.005	-0.006	-0.007
-4	0	-0.001	-0.002	-0.003	-0.004	-0.005	-0.006	-0.007	-0.008