

Drive Axles

GENERAL MOTORS 7 $\frac{1}{2}$ "", 8 $\frac{1}{2}$ "", 8 $\frac{7}{8}$ "", & 9 $\frac{1}{2}$ " RING GEAR

Chevrolet & GMC

C, K, G, S & P10 Models, Rear Axle;
G20 Models, Rear Axle; K10/20 Models,
Front Axle

NOTE: The General Motors 8 $\frac{1}{2}$ " ring gear drive axle is used as the front drive axle on K10/20 models. For removal and installation instructions, see articles on Locking Hubs and 4-Wheel Drive Steering Knuckles. These models may also be equipped with a Spicer front drive axle. See appropriate article in this section.

DESCRIPTION

Axle assembly is hypoid gear type with integral carrier housing. It is used on Light Duty emission vehicles with semi-floating axles. Pinion bearing preload is made with a collapsible spacer. Differential side bearing preload adjustment and drive pinion depth adjustment are made by shims.

A removable 10-bolt housing cover permits inspection and minor servicing of differential, without removal from vehicle. Service procedures are the same for all 4 assemblies, except for tightening specifications and special tool numbers.

AXLE RATIO & IDENTIFICATION

General Motors uses several types of axles. The 7 $\frac{1}{2}$ ", 8 $\frac{1}{2}$ ", 8 $\frac{7}{8}$ " and 9 $\frac{1}{2}$ " axles can be distinguished from others by the configuration of their housing covers and by the number of attaching bolts. To determine drive axle ratio, see article on Drive Axle Ratio Identification in this section.

Fig. 1: General Motors 7 $\frac{1}{2}$ "", 8 $\frac{1}{2}$ "", 8 $\frac{7}{8}$ " & 9 $\frac{1}{2}$ " Ring Gear Cover Gasket

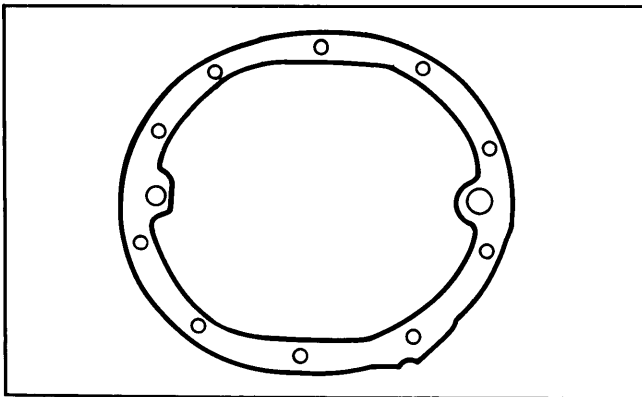

Illustration is for axle identification purposes.

REMOVAL & INSTALLATION

AXLE SHAFTS & BEARINGS

NOTE: For front axle shaft and bearing removal, see articles on Spicer (Dana) Full-Floating Axles or 4-Wheel Drive Steering Knuckles in this section.

Removal

1) Raise vehicle. Remove wheel and brake drums. Drain lubricant from drive axle. Remove housing cover. Remove pinion shaft lock screw.

NOTE: On vehicles equipped with 8 $\frac{7}{8}$ " ring gear and Eaton positive traction differential, proceed to step 3). On all remaining models, proceed to next step.

2) Remove pinion shaft. Push flanged end of axle shaft toward center of vehicle. Remove "C" lock from splined end of axle shaft, and remove axle shaft.

3) On vehicles with 8 $\frac{7}{8}$ " ring gear and Eaton positive traction differential, remove pinion shaft lock screw. Partly withdraw pinion shaft.

4) Rotate differential case until pinion shaft touches edge of housing. See Fig. 2.

Fig. 2: Positioning General Motors Case for Axle Removal.

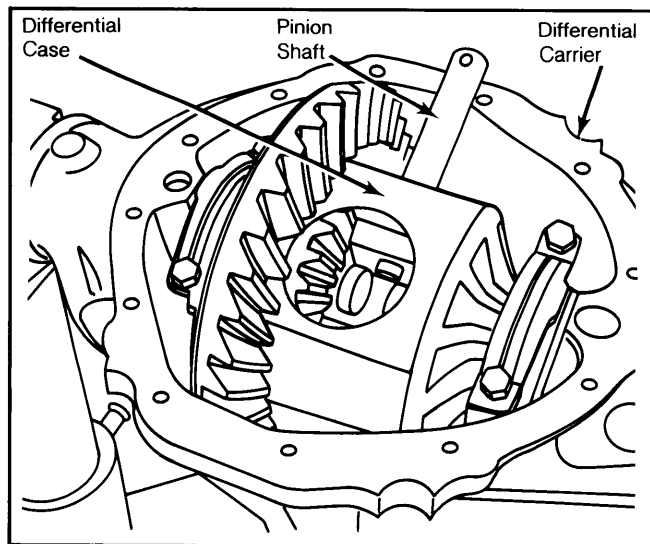

Rotate case until pinion shaft touches edge of housing.

5) Reach into case with screwdriver, and rotate "C" lock until open end points directly inward. When "C" lock is correctly positioned, axle shaft can be pushed inward, allowing "C" lock to be removed. Remove axle shaft. See Fig. 3.

CAUTION: Do not hammer on axle shaft. It should slide easily when "C" lock is correctly positioned. When removing axle shaft on the 9 $\frac{1}{2}$ " ring gear axle, be sure thrust washer in differential case does not slip out.

6) With axle shaft removed, insert bearing removal tool (J-23689 or equivalent) into axle housing behind bearing. Attach slide hammer to tool and remove bearing and seal.

Installation

1) Reverse removal procedure, noting the following. Install axle shaft housing bearing, until it bottoms against housing. Install axle shaft housing seal, until flush with outer edge of axle tube.

2) After installing axle shaft and "C" lock, pull axle shaft outward so "C" lock seats in side gear counterbore. On models equipped with Eaton positive

GENERAL MOTORS 7½", 8½", 8⅞", & 9½" RING GEAR (Cont.)

traction differential, make sure "C" lock is correctly positioned in thrust block. See Fig. 3.

Fig. 3: Correct Positioning of "C" Lock for Removal

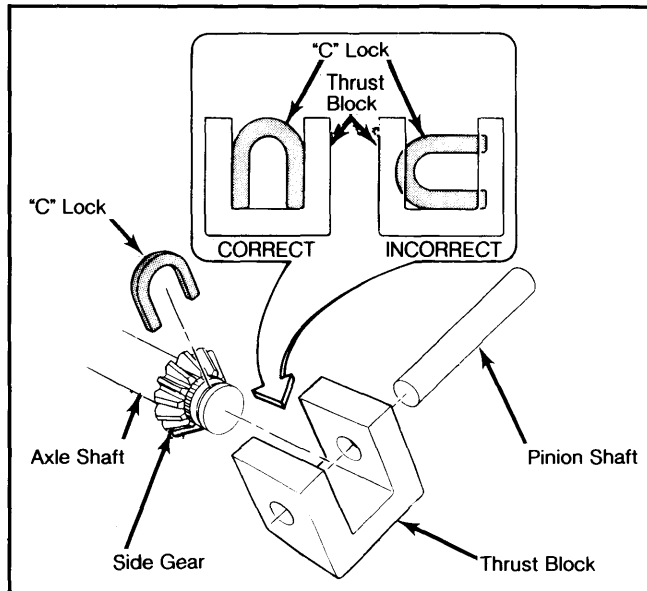

When "C" lock is correctly positioned, axle shaft can be pushed inward.

PINION FLANGE & SEAL

Removal

1) Raise vehicle, and allow axle to hang free. Disconnect universal joint, and tie propeller shaft out of the way. Note and record pinion bearing preload. To do so, rotate pinion shaft through several revolutions, using an INCH lb. torque wrench. Mark relationship of pinion flange and shaft for reassembly.

2) Count the number of threads on pinion shaft. Hold yoke with pinion flange holder (J-8614-10 or 11), and remove self-locking nut. Remove yoke using a puller. Pry old seal from housing.

Installation

1) Pack seal lip cavity with lithium-base extreme pressure lubricant. Place seal in bore. Using gauge plate (J-22804-1) and seal driver (J-21057 or J-23911), drive seal into place. Make sure seal is square in carrier. Pack cavity between end of pinion splines and pinion flange with a non-hardening sealer.

2) Using pinion flange holder (J-8614-10 or 11), install flange on pinion shaft. Install washer and nut in original position, taking note of scribe marks and number of exposed threads. Measure pinion preload. Tighten nut in small increments, until preload exceeds original figure by 1-5 INCH lbs. (.1-6 N.m). Install propeller shaft, and lower vehicle.

CAUTION: Do not attempt to hammer flange onto pinion shaft, as it will damage ring gear and pinion.

AXLE ASSEMBLY

Removal

1) Raise vehicle. Raise axle until tension is released from springs and shock absorbers. Disconnect propeller shaft from flange. Tie propeller shaft out of way.

2) Disconnect shock absorbers at lower mounts. Disconnect vent hose from vent connector. Disconnect and plug brake hose at connector on axle housing.

3) Remove rear brake drums. Disconnect parking brake cable at actuating levers and at flange plate. Remove "U" bolt nuts, washers, spacers and clamp plates. Lower axle assembly and remove from vehicle.

Installation

To install axle assembly, reverse removal procedure. Bleed brake system.

OVERHAUL

DISASSEMBLY

NOTE: Check and record ring gear backlash and pinion bearing preload before disassembly.

1) Remove lock screws retaining pinion shaft, and remove pinion shaft. Remove axle shafts, and roll out differential pinions and thrust washers. Mark pinions and thrust washers for reassembly. Remove side gears and thrust washers. Mark side gears and thrust washers for reassembly.

2) Mark differential bearing caps and housing for reassembly. Loosen bearing cap bolts, and tap surface of bearing caps to loosen. Using pry bar inserted in differential carrier, pry against housing to remove carrier.

NOTE: Be careful, as carrier bearings are preloaded. Carrier will fall free after being pried past a certain point.

3) After removing carrier, place bearing cups with appropriate shims. Install bearing caps onto housing in their original position prior to removal. Using puller (J-22888 & J-8107-2 for 7½" ring gear, J-8107-4 for 8½" & 8⅞" ring gears or J-8107-3 for 9½" ring gear), remove differential side bearings.

4) Remove ring gear bolts, and tap ring gear off carrier using a soft drift and hammer. Using an INCH lb. torque wrench, check torque required to rotate drive pinion. If no preload reading is obtained, check for looseness of pinion assembly. Looseness indicates pinion bearings should be replaced.

5) Install holder (J-8614-10 or 11) on flange, with notches toward flange. Remove pinion nut and washer, and remove flange. Install pinion nut half way on pinion. Install differential cover using 2 bolts. Tap end of pinion, using soft drift and large hammer to remove pinion.

NOTE: Care must be used to avoid damaging pinion bearings, when removing pinion from differential housing.

6) Remove differential cover, and remove pinion assembly. Remove pinion oil seal and front bearing from housing. Inspect bearings and bearing cups, and replace as required. Discard oil seal, pinion nut and collapsible spacer.

CLEANING & INSPECTION

1) Clean all parts in cleaning solvent. Inspect all bearings, bearing cups, races and rollers for scoring,

Drive Axles

GENERAL MOTORS 7½", 8½", 8⅞", & 9½" RING GEAR (Cont.)

chipping or excessive wear. Inspect axle shaft and side gear splines for excessive wear.

2) Inspect ring gear and pinion for scoring, cracking or chipping. Inspect differential case, pinion side gears, thrust washers and pinion shaft for cracks, scoring, galling or excessive wear.

REASSEMBLY & ADJUSTMENT

Case Assembly

Using guide pins if necessary, install ring gear squarely onto case. Tighten ring gear bolts evenly and alternately. Install side gears, differential pinions and thrust washers into case. Install differential pinion shaft and lock screw, and tighten lock screw finger tight.

Drive Pinion Depth & Bearing Preload

1) Drive pinion rear bearing shim thickness must be determined whenever a new axle housing, ring and pinion set, or pinion bearings are installed. Shim pack thickness is determined by using gauging tool set (J-21777).

2) If removed, install pinion bearing cups into housing. Place lubricated pinion bearings into cups. Position gauge plate (J-23597-11 for 7½"; J-21777-29 for 8½"; J-21777-36 for 8⅞"; or J-21777-85 for 9½" ring gear) and rear pinion bearing pilot on preloaded stud.

3) Install through rear pinion bearing, front pinion bearings and front pinion bearing disc (J-21777-42). Install hex nut until snug. Rotate bearings to insure proper seating. Hold preload stud stationary with a wrench on flats. Tighten hex nut until 20 INCH lbs. (2.2 N.m) are required to rotate bearings. See Fig. 4.

Fig. 4: Sectional View of Pinion Depth Tool Set (J-21777)

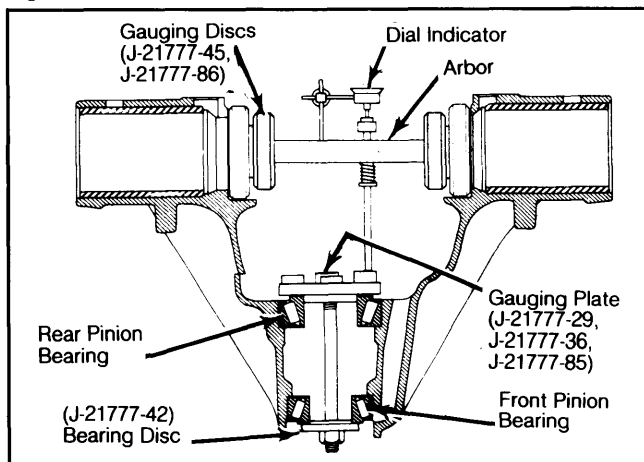

Appropriate discs & plates must be used with each differential.

4) Mount side bearing gauging discs (J-21777-45) on ends of arbor. Place arbor into carrier making sure discs are properly seated. Install side bearing caps and bolts. Tighten bolts to avoid movement.

5) Position dial indicator on mounting post of arbor, with contact button resting on top surface of plunger. Preload dial indicator ½ revolution, then tighten in this position.

6) Place plunger onto gauging area of gauge plate. Rock plunger rod slowly back and forth across gauging area until dial indicator reads greatest deflection. Set indicator to zero. Repeat rocking action several times to verify setting.

7) Once zero reading is obtained, swing plunger until it is removed from gauging area. Dial indicator will now read required pinion shim thickness for a "nominal pinion". Record this reading.

8) Check drive pinion for painted or stamped markings on pinion stems, or for a stamped code number on small end of pinion gear. If marking is found to be plus or minus number (for example, +2 or -5) add or subtract that many thousandths of an inch from indicator reading. This will then be the required thickness of rear pinion bearing shim pack.

NOTE: If no markings are found on pinion, use dial indicator reading as shim thickness.

9) Remove bearing caps and gauging tool from housing. Place selected shim pack on pinion gear. Using a press, install lubricated pinion bearing onto pinion shaft.

10) Install a new collapsible spacer over pinion gear shaft. Position pinion assembly in housing. While holding pinion forward, carefully drive front pinion bearing onto pinion gear shaft until a few threads are exposed.

11) Install seal, pinion flange, washer and nut. Tighten until all end play is removed. Rotate pinion several times to seat bearings. Check preload using an INCH lb. torque wrench.

12) Continue tightening nut, and checking preload until specified preload is obtained. Do not back off nut to lessen preload. If preload is exceeded, a new collapsible spacer must be installed, and nut must be retightened until proper preload is obtained.

Side Bearing Preload

1) Lubricate bearings, and place differential assembly into position in housing. Hold in place by hand.

2) Install bearing strap (J-22779-6) on left bearing. Tighten bolts evenly to a snug fit. Install right bearing cap. Tighten bolts to a snug fit.

3) Position ring gear tight against pinion, so that backlash is .000-.001" (0-.025 mm). Insert gauging tool (J-22779) between left bearing cup and carrier housing.

4) While moving tool up and down, tighten adjusting nut until a slight drag is felt. Tighten lock bolt on side of tool.

5) Install .170" (4.32 mm) adjustment spacer and shim between right bearing and carrier. Insert a feeler gauge, thick enough to create a slight drag, between shim and carrier.

6) To determine correct side bearing shim thickness, measure thickness of adjusted gauging tool. Record measurement. Add together dimensions of shim, spacer and feeler gauge. Record measurement.

7) Subtract .010" (.25 mm) from ring gear (left) side measurement and add .010" (.25 mm) to opposite (right) side measurement. This allows for correct backlash adjustment.

8) To obtain correct preload, add .004" (10 mm) to both measurements. The total is the correct shim pack thickness for each side.

Example:

Ring Gear Side (Left) Shim Pack
 .250" (Gauging Tool Measurement)
 -.010" (Backlash Adjustment)
 +.004" (Bearing Preload)
 =.244" (Ring Gear Side Shim Pack)

GENERAL MOTORS 7½", 8½", 8⅞", & 9½" RING GEAR (Cont.)

Opposite Ring Gear Side (Right) Shim Pack
 .265" (Combined Measurement Total)
 + .010" (Backlash Adjustment)
 + .004" (Bearing Preload)
 = .279" (Opposite Ring Gear Side Shim Pack)

9) Install ring gear side shim first. Wedge opposite side shim between bearing cup and spacer. Install shim so that chamfered side is against spacer.

NOTE: If shim is not chamfered enough, and it scrapes spacer when it is installed, file or grind chamfer before installation.

10) It may be necessary to partially remove differential, when right side shim is being installed. Tap shim into place with a soft-faced hammer. Tighten bearing cap bolts.

Backlash & Final Assembly

1) Check backlash at 4 locations around ring gear, using a dial indicator mounted to axle housing. Variation should not exceed .001" (.025 mm). If backlash is not within specifications, adjust side bearing shims as necessary.

CAUTION: Total shim pack thickness must not be changed. If a shim is removed from 1 side, the same thickness shim must be added to the other side.

2) After adjustment is completed, make a tooth contact pattern test, and make any necessary corrections. Install axle shafts and housing cover.

TIGHTENING SPECIFICATIONS

Application	Ft. Lbs. (N.m)
Ring Gear-to-Differential Case	
7½" Ring Gear	1 90 (120)
8½" Ring Gear	80 (109)
8⅞" Ring Gear	60 (82)
9½" Ring Gear	110 (150)
Side Bearing Cap	
7½", 8½" & 8⅞"	55 (75)
9½" Ring Gear	65 (88)
Pinion Shaft Lock Bolt	20 (27)

1 — Use new bolts. Do not reuse old bolts.

AXLE ASSEMBLY SPECIFICATIONS

Application	In. (mm)
Ring Gear Backlash005-.008 (.13-.20)
Side Bearing Preload008 (.20)

Application	INCH Lbs. (N.m)
Pinion Bearing Preload	
7½" Ring Gear	
Used Bearings	8-12 (1.0-1.4)
New Bearings	24-32 (2.7-3.6)
8½" & 8⅞" Ring Gear	
Used Bearings	5-10 (.6-1.13)
New Bearings	15-30 (1.7-3.4)
9½" Ring Gear	
Used Bearings	5-15 (.6-1.7)
New Bearings	20-25 (2.3-2.8)

Fig. 5: Exploded View of General Motors 7½", 8½", 8⅞" & 9½" Ring Gear Axle Assembly

