

## 6.6 LITER V8

### IDENTIFICATION CODING

#### ENGINE IDENTIFICATION

Engine is identified by a letter code in eighth position of Vehicle Identification Number. VIN is located near windshield, on left upper side of instrument panel. The VIN number is also located on the Safety Compliance Certification Label, located on left door lock pillar.

#### ENGINE IDENTIFICATION CODE

Engine	Code
6.6L (400") 2-Bbl. ....	Z

#### ENGINE REMOVAL

See Engine Removal at end of ENGINE Section.

### CYLINDER HEAD & MANIFOLD

#### INTAKE MANIFOLD

##### Removal

1) Remove air cleaner and air inlet duct. If A/C equipped, remove compressor. Disconnect all wires from coil. Disconnect any electrical connections that will interfere with intake manifold removal, and position aside.

2) Disconnect spark plug wires from spark plugs, and remove wires from harness brackets at rocker arm covers. Remove distributor cap and wires as an assembly. Remove thermactor by-pass valve and hose from check valve.

3) Remove fuel inlet line at carburetor. Label and disconnect vacuum hoses from intake manifold, carburetor and distributor. Position heater hoses aside. Remove coil, vacuum solenoid valve and bracket. Remove distributor and plug hole in cylinder block with a clean cloth.

4) Disconnect accelerator linkage and speed control cable. If equipped, disconnect transmission down-shift linkage from carburetor, and remove carburetor. Remove intake manifold and discard valley baffle and seals.

##### Installation

1) Clean all gasket mating surfaces. Apply a  $\frac{1}{8}$ " bead of silicone sealer to 4 corners of cylinder head-to-block seal mounting surface junction (area where front and rear seal ends butt to cylinder head). Position new seals on block and press locating extensions into holes in mating surface.

Fig. 1: Intake Manifold Tightening Sequence

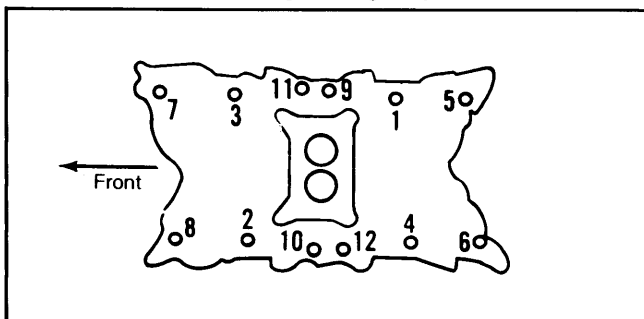

Tighten  $\frac{1}{4}$ " bolts to 19-25 ft. lbs. (26-33 N.m), and  $\frac{3}{8}$ " bolts to 22-32 ft. lbs. (30-43 N.m).

2) Apply a  $\frac{1}{16}$ " bead of silicone sealer to outer ends (along full width) of front and rear intake manifold seals. Place manifold valley baffle in position. Make sure all alignment notches are under dowels on cylinder head, and holes in valley baffle are aligned with holes in head.

**CAUTION: Do not apply sealer to waffle section of front and rear seals, as sealer will rupture the seals.**

3) Install manifold in position and tighten bolts. See Fig. 1. Reverse removal procedures to complete installation. Retighten manifold bolts after engine has reached operating temperature.

#### CYLINDER HEAD

##### Removal

1) Remove intake manifold and rocker arm covers. Remove rocker arm bolts, oil deflectors, fulcrum seats and rocker arms. Remove push rods in sequence, for re-installation in original locations.

2) To remove left cylinder head, remove A/C compressor (if equipped). Remove power steering pump from left cylinder head, and position aside.

3) For right cylinder head removal, remove alternator mounting bracket through bolt from right cylinder head. Remove air cleaner inlet duct, and disconnect ground wire from rear of head.

4) Disconnect exhaust pipes at manifolds. Remove cylinder head bolts and lift cylinder head from block. Remove and discard head gasket

##### Installation

1) Clean all gasket surfaces. Check cylinder head and block for flatness. Place new head gasket over dowel pins on cylinder block. Place cylinder heads on block. Install and tighten head bolts in 2 steps. It is not necessary to retighten head bolts after extended operation. See Fig. 2.

Fig. 2: Cylinder Head Tightening Sequence

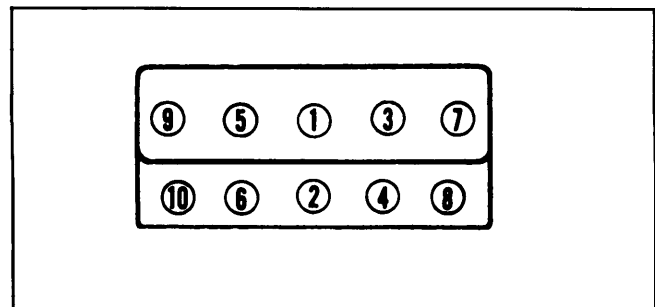

Tighten first to 75 ft. lbs. (102 N.m); then to 95-105 ft. lbs. (129-142 N.m).

2) Lubricate push rods ends and valve stem tips with polyethylene grease (or equivalent). Install push rods in their original locations. Lubricate rocker arms and fulcrum seats with heavy duty engine oil, and install in their original locations. Install remaining components.

### VALVES

#### VALVE ARRANGEMENT

E-I-E-I-E-I-E-I (Left bank, front to rear)  
I-E-I-E-I-E-I-E (Right bank, front to rear)

# Ford V8 Engines

## 6.6 LITER V8 (Cont.)

### VALVE GUIDE SERVICING

When reaming valve guides, always use reamers in proper sequence. Always reface valves and seats after guide is reamed. Use a scraper to break sharp corner at top of valve guide bore (ID), after reaming. Replacement valves are available with .003" (.08 mm), .015" (.38 mm), and .030" (.76 mm) oversize stems.

### VALVE STEM OIL SEALS

Cup-type oil seals are used on valves. Lubricate valve stem with engine oil, and install seal with cup side down over valve guide. Use a  $\frac{5}{8}$ " deep-well socket and light mallet to seat seal on valve stem.

### VALVE SPRINGS

#### Removal

1) Remove air cleaner and intake duct assembly. Remove hoses and wires from rocker arm cover, and remove cover. Remove spark plug from cylinder being serviced. Turn crankshaft until piston to be serviced is at TDC at end of compression stroke. Install an air line with adapter in spark plug hole, and apply air pressure.

2) Remove required rocker arm and push rod. Install fulcrum bolt. Using spring compressor tool, compress valve spring and remove retainer locks. Remove tool, and remove spring retainer, valve spring, and valve stem oil seal. See Fig. 3.

**CAUTION:** Do not remove air pressure, until all components are reinstalled.

Fig. 3: Valve Assembly

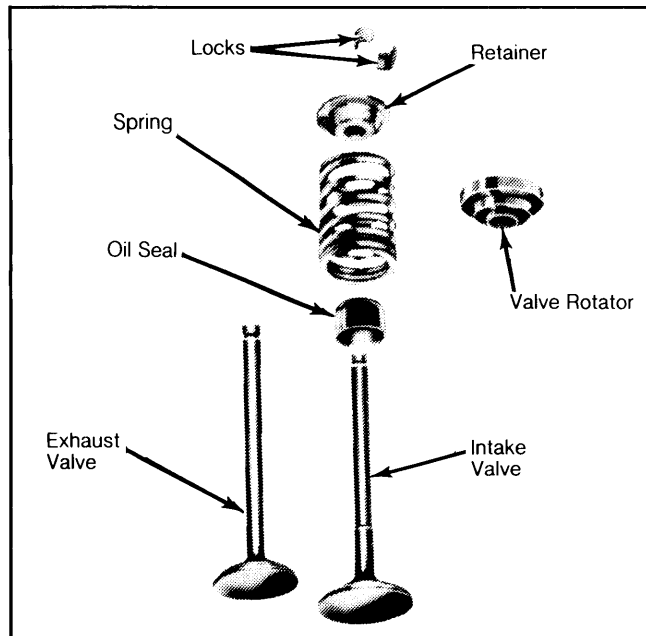

Install valve rotator on exhaust valves only.

#### Inspection

1) Inspect valve stem for damage, wear, or binding in valve guide. Check valve spring for proper pressure using valve spring tester. Replace springs that fail to meet specifications. See *Valve Springs* table.

2) Inspect each spring for squareness using a steel square and flat surface. Observe gap between top coil of spring and square, while slowly rotating spring.

Replace spring if more than  $\frac{5}{64}$ " (1.98 mm) out-of-square. See Fig. 4.

Fig. 4: Checking Valve Spring Squareness

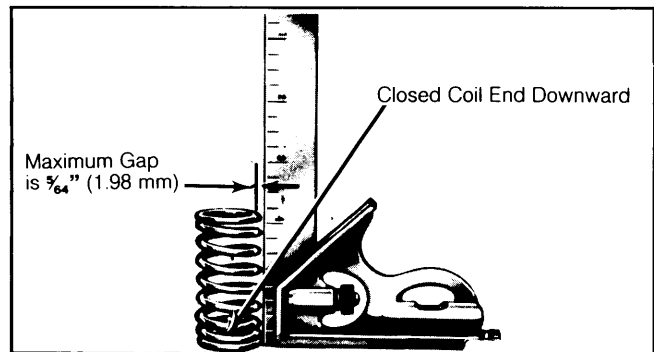

Measure gap, while slowly rotating spring.

#### Installation

1) Lubricate valve stem with heavy duty engine oil, and install new valve stem seal. Place valve spring over valve and install spring retainer (or rotator). Compress spring with spring compressor, and install retainer locks.

2) Apply polyethylene grease (or equivalent) to ends of push rod and valve stem tip. Install rocker arm and tighten fulcrum bolt. See *VALVE CLEARANCE ADJUSTMENT* in this article to check valve clearance.

3) Remove air line and adapter, and install spark plug. Reverse removal procedure to install remaining components.

### VALVE SPRING INSTALLED HEIGHT

1) Using dividers and a scale, measure assembled height of valve spring. Measure from surface of cylinder head spring pad to underside of spring retainer (or rotator). See Fig. 5.

2) Installed height for intake valves is  $1\frac{1}{16}$ - $1\frac{27}{32}$ " (46.05-46.84 mm). Exhaust valve installed height is  $1\frac{1}{16}$ - $1\frac{29}{32}$ " (42.85-44.45 mm). If height is greater than specified, install .030" (.76 mm) spacer(s) between cylinder head spring pad and valve spring, to correct spring height.

**CAUTION:** Install spacers only if necessary. Excess use of spacers will overstress the valve train, causing unnecessary damage.

Fig. 5: Checking Installed Height of Valve Spring

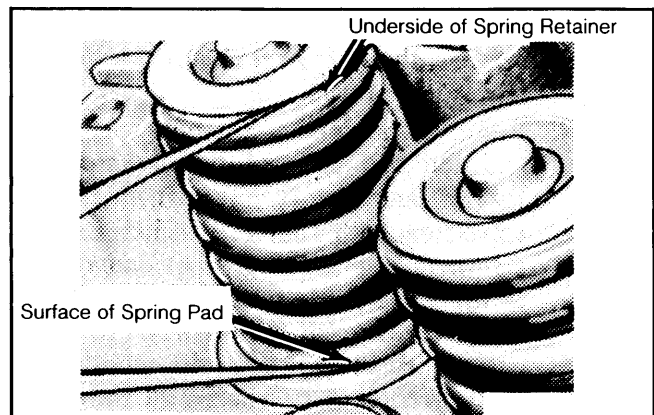

Do not install spacer(s) unless necessary.

## 6.6 LITER V8 (Cont.)

### ROCKER ARM ASSEMBLY

Inspect rocker arms, fulcrum seats and fulcrum bolts for excessive wear or damage, and correct as necessary. Be sure that the fulcrum seat base is seated in slot on cylinder head before tightening fulcrum bolt. See Fig. 6.

**Fig. 6: Rocker Arm Assembly**

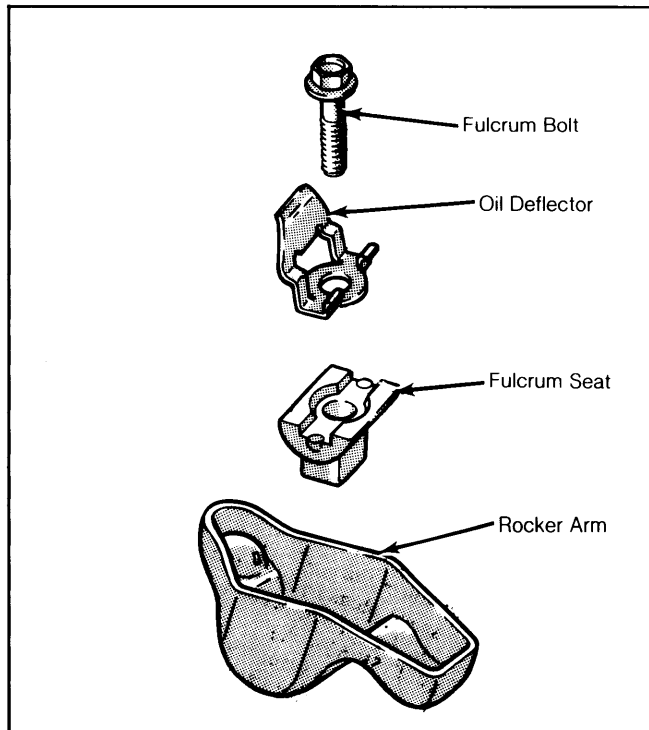

Lubricate rocker arms and fulcrum seats with heavy duty engine oil prior to installation.

### HYDRAULIC VALVE LIFTER ASSEMBLY

1) Service lifters as assemblies only. Disassemble lifters and clean, prior to testing. Test lifters with hydraulic lifter test fluid. Do not interchange parts between lifters. See Fig. 7.

**Fig. 7: Hydraulic Valve Lifter Assembly**

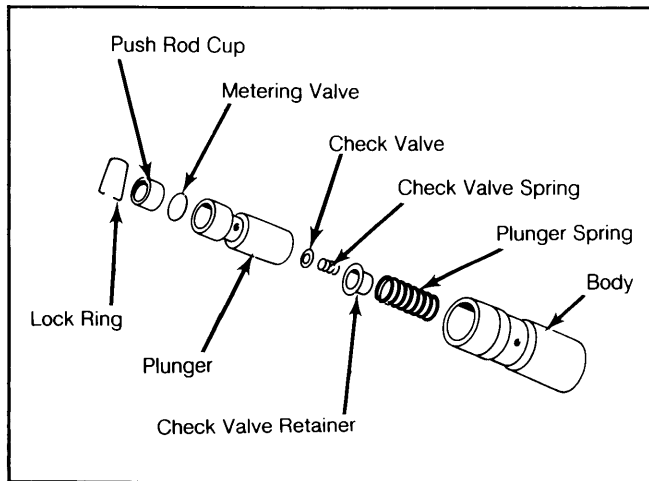

Parts are not interchangeable between lifters.

2) Leak-down rate on hydraulic lifters is 10-50 seconds at  $\frac{1}{16}$ " (1.59 mm) plunger travel (under a 50 lb., 22.68 kg load). Replace lifter if any sign of wear or damage is noted, or if lifter fails leak-down test.

### VALVE CLEARANCE ADJUSTMENT

1) Turn crankshaft to place No. 1 piston at TDC (end of compression stroke). With crankshaft in this position, make chalk marks at points 1, 2 and 3, approximately 90° apart. See Fig. 8.

**Fig. 8: Crankshaft Positions for Checking Valve Clearance**

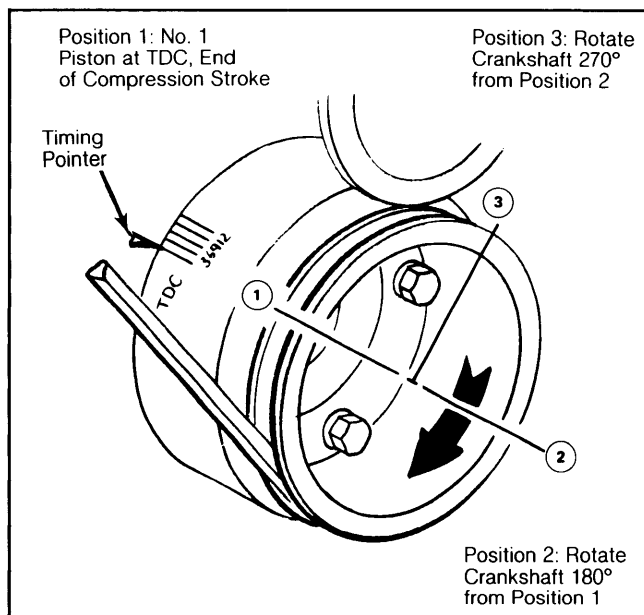

Space chalk marks approximately 90° apart.

2) Using Fig. 8 as a reference, check clearance of valves listed in VALVE CLEARANCE ADJUSTMENT table, using the following procedure:

3) Using lifter bleed-down tool, apply pressure to push rod end of rocker arm. Slowly bleed down lifter, until lifter plunger is completely bottomed. Hold lifter in this position and check clearance between rocker arm and valve stem tip with a feeler gauge.

4) Desired collapsed lifter gap clearance is .125-.175" (3.18-4.45 mm); allowable clearance is .100-.200" (2.54-5.80 mm). If clearance is less than specified, install a .060" (1.52 mm) shorter push rod; if clearance is greater, install a .060" (1.52 mm) longer push rod.

### VALVE CLEARANCE ADJUSTMENT

Crankshaft Position	Check Int. Nos.	Check Ex. Nos.
1	1, 4, 8	1, 3, 7
2	3, 7	2, 6
3	2, 5, 6	4, 5, 8

### PISTON, PINS & RINGS

#### OIL PAN

See Oil Pan Removal at end of ENGINE Section.

# Ford V8 Engines

## 6.6 LITER V8 (Cont.)

### PISTON & ROD ASSEMBLY

#### Removal

1) With cylinder head and oil pan removed, use a ridge reamer to remove any ridge or deposits on upper end of cylinder bore. Piston must be at bottom of stroke and covered with cloth to collect cuttings.

**NOTE:** Never cut more than  $\frac{1}{32}$ " into ring travel area of bore, when removing ridge.

2) Inspect connecting rods and caps for cylinder identification and mark as necessary. Remove rod cap and push piston and rod assembly out top of block, taking care not to nick crankshaft journal or cylinder wall. Install rod cap on mating rod.

#### Installation

1) Lightly coat cylinder bores, pistons and rings with engine oil. Make sure ring gaps are properly spaced. See Fig. 9. Compress piston rings with ring compressor, ensuring position of rings does not change.

**Fig. 9: Spacing Piston Ring Gaps**

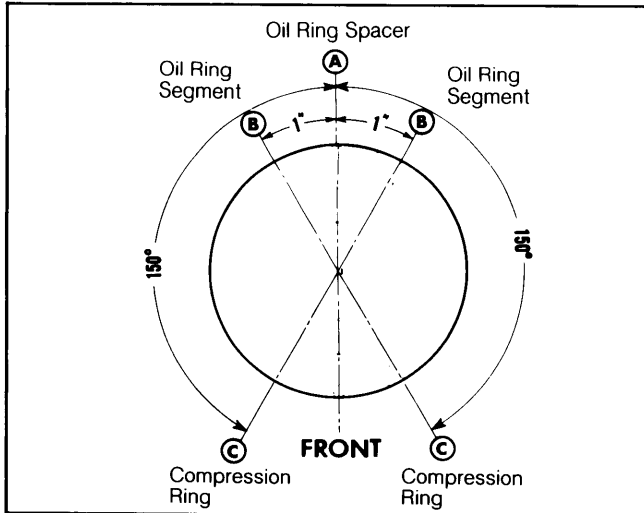

Space each oil ring segment 1" (25.4 mm) from oil ring spacer.

2) With crankshaft journal positioned at bottom of stroke, install each piston and rod assembly in cylinder bore. Notch (or arrow) on piston must face toward front of engine, and numbered side of connecting rod must face outboard side of engine.

3) Push piston downward until rod bearing seats on crankshaft journal. Install and tighten connecting rod cap. Check side clearance between connecting rods on each crankshaft journal.

### FITTING PISTONS

**NOTE:** Take measurements at normal room temperature (70°F, 21°C).

1) Measure piston at centerline of piston pin, and at 90° to piston pin axis. Measure cylinder bore 90° to crankshaft centerline, at top, middle, and bottom of bore. Use measurements to determine piston-to-cylinder bore clearance.

2) Measure cylinder bore 90° to crankshaft centerline at top of bore (below ring travel) and at bottom of bore (above ring travel). Taper is the difference

between the 2 measurements, and must not exceed .010" (.25 mm).

3) Measure cylinder bore at center of piston travel, 90° to crankshaft centerline. Measure bore at center of piston travel, in line with crankshaft centerline. Out-of-round is the difference between the 2 measurements, and must not exceed .005" (.13 mm).

4) If taper or out-of-round are not within limits, or cylinder walls are deeply scored, hone or bore cylinders for installation of new pistons. Check Piston Size Code Chart.

### PISTON SIZE CODE CHART

Code	Piston Size In. (mm)
Red .....	3.9982-3.9988 (101.554-101.570)
Blue .....	3.9994-4.0000 (101.585-101.600)
.003" Oversize .....	4.0006-4.0012 (101.615-101.630)

### FITTING RINGS

1) Position ring in cylinder bore at a point where normal ring wear is not present. Use care not to damage ring or cylinder bore. Ring must be square in bore. Check ring end gap with a feeler gauge.

2) Check side clearance of compression rings with feeler gauge inserted between ring and its lower land. Feeler gauge should slide freely around entire circumference of piston without binding. If lower lands have high steps, replace piston.

### PISTON PINS

#### Removal

Using an arbor press and piston pin remover/installer tool (T68P-6135-A or equivalent), press out piston pin. See Fig. 10.

**Fig. 10: Tool Layout for Removing & Installing Piston Pin**

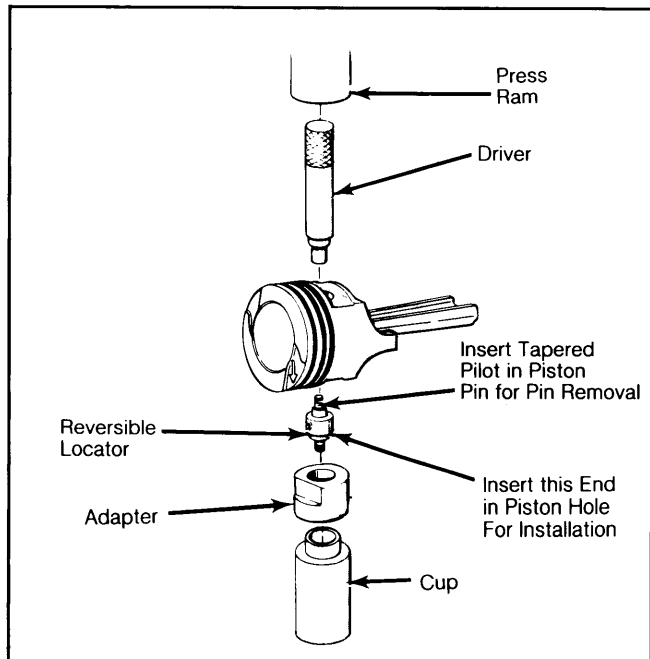

Large chamfered side of rod's bearing bore end, must face forward on right bank, and rearward on left bank.

## 6.6 LITER V8 (Cont.)

### Installation

1) Apply light coat of engine oil to parts being assembled. Assemble piston to connecting rod with numbered side of connecting rod and arrow on piston positioned as shown in Fig. 11.

**Fig. 11: Correct Positioning of Connecting Rod-to-Piston**

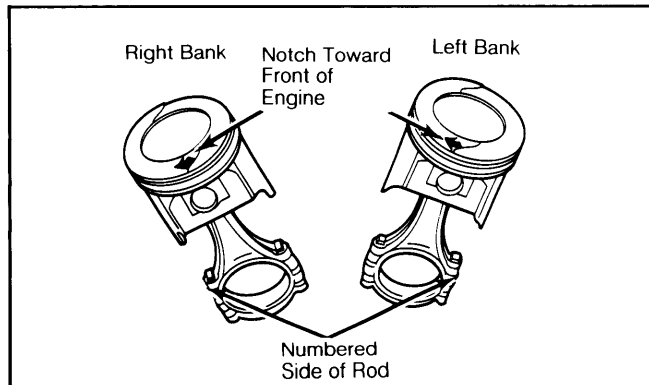

Numbered side of rods will face outboard side of engine, when installed.

2) When installing replacement (new) connecting rods, note the following: On right-bank rods, install large-chamfered side of rod's bearing bore end, facing same side as notch (or arrow) on piston head (front of engine). For left-bank rods, install large-chamfered side of rod's bearing bore end, facing opposite notch (or arrow) on piston head (rear of engine).

3) Start piston pin in piston and connecting rod. Using arbor press and piston pin remover/installer tool, press pin into connecting rod until pin is centered in piston. See Fig. 10.

## CRANKSHAFT & ROD BEARINGS

### MAIN & CONNECTING ROD BEARINGS

**NOTE:** Use Plastigage method for checking bearing clearances. Following procedures are per-

formed with oil pan and oil pump removed, and oil film removed from surfaces to be checked.

### Connecting Rod Bearings

1) Ensure rod caps are marked for cylinder identification. Place crankshaft journal of cylinder to be checked at bottom of stroke and remove rod cap.

2) Place strip of Plastigage on bearing surface over full width of cap about 1/4" off center, and away from oil holes. Install cap and tighten to specifications. Do not allow crankshaft to turn.

3) Remove cap and measure width of Plastigage with scale furnished. A standard bearing may be used in combination with a .001" (.025 mm) or .002" (.051 mm) undersize bearing to obtain proper bearing clearance. With rod cap and bearing installed, check connecting rod side clearance. See Fig. 12.

**Fig. 12: Measuring Connecting Rod Side Clearance.**

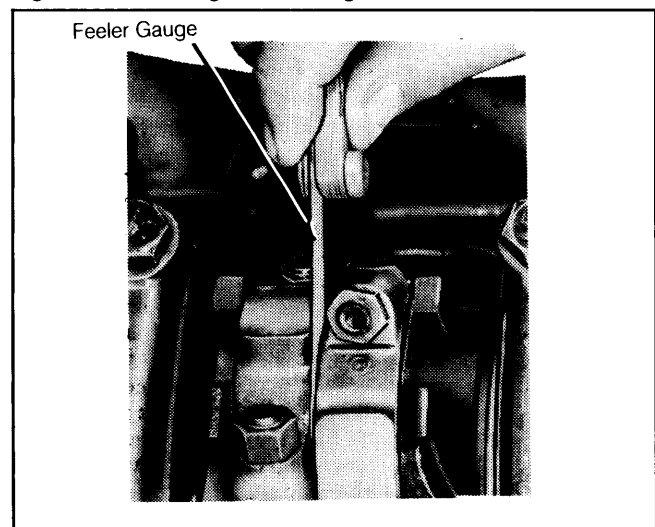

Side clearance is .010-.020" (.25-.51 mm).

### Main Bearings

1) Fit main bearings 1 at a time, while leaving other bearings securely fastened. Make sure main bearing

**Fig. 13: Aligning Thrust Bearing**

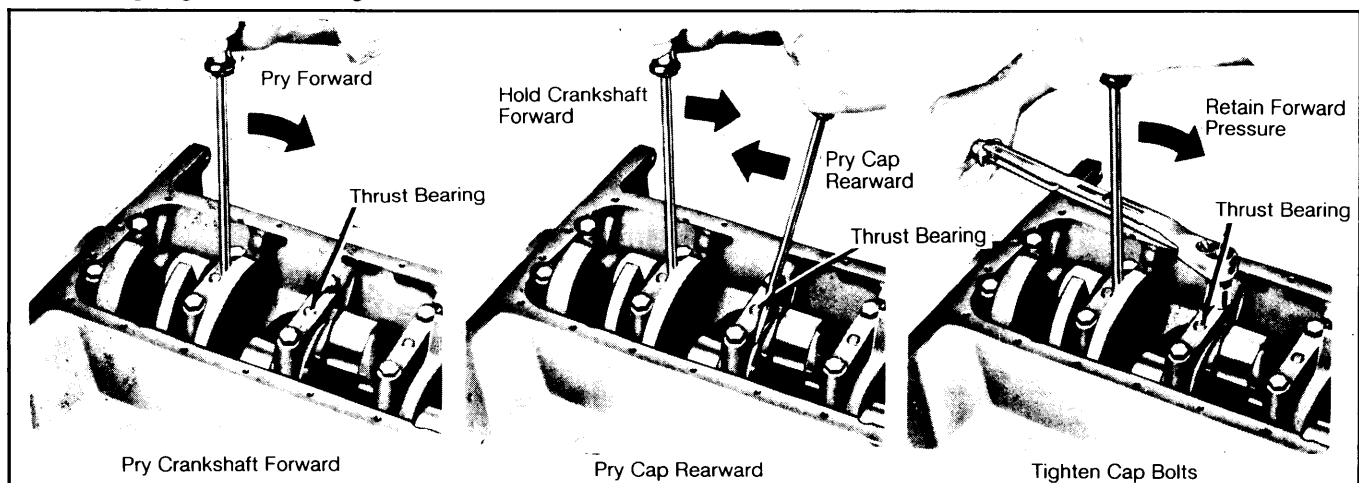

Align thrust bearing after all other bearings have been tightened.

# Ford V8 Engines

## 6.6 LITER V8 (Cont.)

caps are marked for identification. Remove main bearing cap. Support crankshaft weight with a jack. Position jack under counterweight, next to bearing being checked.

2) Use Plastigage method (as explained in Connecting Rod Bearings) to measure main bearing clearance, tightening caps to specifications.

3) Standard size bearings may be used in combination with a .001" (.025 mm) or .002" (.051 mm) undersize bearings. If .002" (.051 mm) undersize main bearings are used on more than 1 journal, bearings must be installed in cylinder block side of crankshaft journal.

4) Replace main bearing sets 1 at a time, while leaving other bearings securely fastened. Remove bearing cap to which new bearings are to be installed.

5) Insert upper bearing remover/installer tool (6331 or equivalent) into crankshaft journal oil hole. Turn crankshaft in direction of engine rotation, forcing upper bearing out of block.

6) Lightly oil bearing and journal surfaces. Partially install plain end of upper bearing in place. Insert tool (6331 or equivalent) into journal oil hole. Turn crankshaft slowly in opposite direction of engine rotation until bearing is seated, then remove tool. Install and tighten main bearing cap.

### THRUST BEARING ALIGNMENT

Install thrust bearing cap after all other main bearing caps have been tightened. Install thrust bearing cap bolts finger tight. Pry crankshaft forward against thrust surface of upper half of bearing. Hold crankshaft forward, and pry thrust bearing cap to rear. Tighten cap bolts while retaining forward pressure on crankshaft. See Fig. 13.

### REAR MAIN BEARING OIL SEAL

#### Removal

1) Remove oil pan and oil pump. Loosen all main bearing cap bolts to slightly lower crankshaft. Do not lower more than  $\frac{1}{32}$ ".

2) Remove rear main bearing cap and remove lower oil seal half. Use seal removing tool to remove upper seal. If tool is not available, install a small metal screw in one end of the seal, and pull on screw to remove seal. Use care not to damage crankshaft seal surface.

3) If equipped, remove oil seal retaining pin from bearing cap. The pin is not used with the split-lip type seal.

#### Installation

1) Carefully clean oil seal grooves in bearing cap and block. Dip split-lip seal halves in engine oil. Carefully install upper seal into groove in cylinder block, with lip (undercut side) toward front of engine.

**CAUTION: Avoid shaving any rubber from outside diameter of seal when installing in groove. Do not allow oil to get onto area where sealer will be applied.**

2) Rotate seal on crankshaft journal until approximately  $\frac{3}{8}$ " of seal protrudes below parting surface. See Fig. 14.

3) Tighten all main bearing cap bolts, except rear main. Install lower seal in rear main bearing cap with undercut side of seal toward front of engine. Allow seal to protrude approximately  $\frac{3}{8}$ " above parting surface, to mate with upper seal when cap is installed.

Fig. 14: Installing Rear Main Bearing Oil Seal

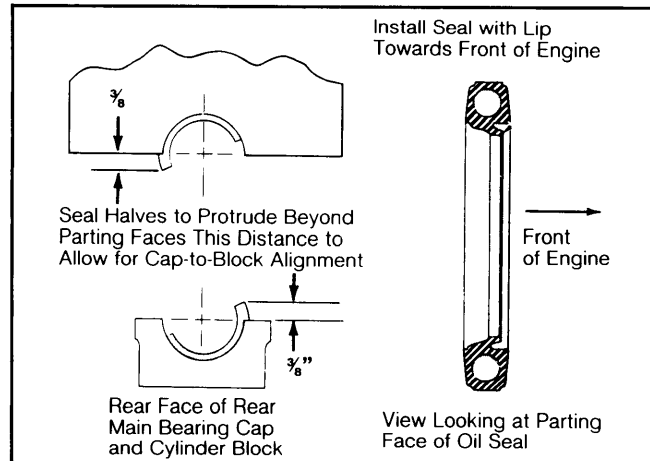

Use care not to damage crankshaft or new oil seal.

4) Apply  $\frac{1}{16}$ " bead of RTV sealer to both sides of cylinder block-to-cap mating surface, and to both sides of bearing cap. See Fig. 15. Install and tighten rear main bearing cap before sealer sets up (approximately 15 minutes). Install oil pump and pan.

Fig. 15: Silicone Sealer Application Points

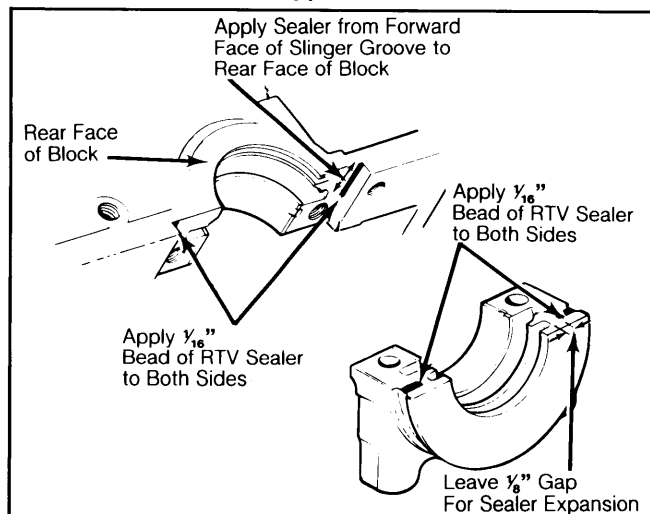

Do not allow sealer to contact lip of seal.

## CAMSHAFT

### ENGINE FRONT COVER

#### Removal

1) Drain cooling system and disconnect battery. Remove fan shroud and position rearward. Remove fan and spacer from water pump. If A/C equipped, remove belt and lower idler pulley. Remove compressor mounting bracket at water pump.

2) Remove alternator drive belt and power steering drive belt. Remove water pump pulley. Remove alternator bracket from water pump and position out of way. Remove power steering pump bracket and position out of way.

3) Disconnect heater hose and lower radiator hose from water pump. Remove crankshaft pulley,

## 6.6 LITER V8 (Cont.)

vibration damper and timing pointer. Remove engine front cover and water pump as an assembly.

### Installation

1) Clean all gasket surfaces. Coat gasket surfaces of block and front cover with gasket sealer, and position new gasket on block. Place front cover on cylinder block. Coat threads of attaching bolts with oil resistant sealer, and install and tighten bolts.

2) Apply polyethelene grease (or equivalent) to oil seal rubbing surface on damper inner hub, and install vibration damper. Remove oil pan and install new gaskets and seals. Reverse removal procedure to complete installation.

### FRONT COVER OIL SEAL

**NOTE:** Front cover oil seal may be replaced without removing front cover, using seal removing tool (T70P-6B070-B) and seal installing tool (T70P-6B070-A)

### Removal

Remove front cover. Using pin punch, drive out old seal. Take care not to damage seal recess in front cover.

### Installation

Coat seal lip with polyethelene grease (or equivalent). Drive seal into front cover recess, using seal installer tool. Check seal for proper positioning in front cover recess. Reassemble in reverse order of removal.

### TIMING CHAIN

**NOTE:** The following procedures are performed with engine front cover removed.

### Checking Timing Chain Deflection

1) Rotate crankshaft counterclockwise (as viewed from front of engine), to take up slack on left side of timing chain. Establish a reference point on the block and measure from this point to left side of chain. See Fig. 16.

**Fig. 16: Measuring Timing Chain Deflection**

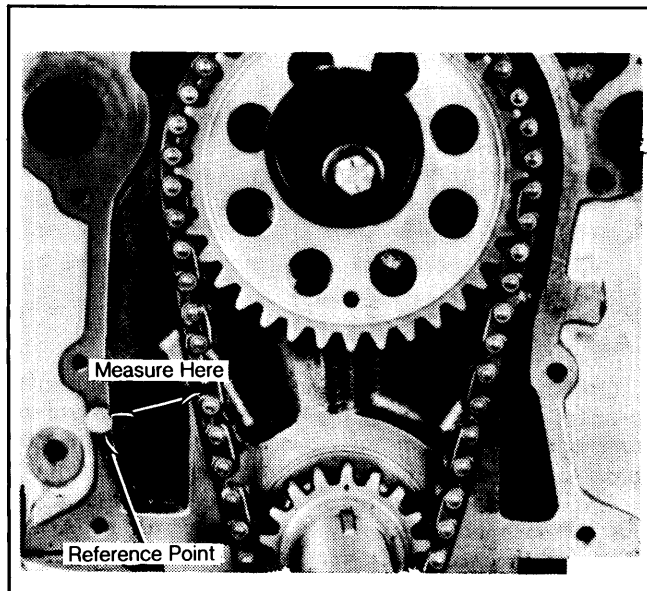

Maximum deflection is  $\frac{1}{2}$ " (12.7 mm).

2) Rotate crankshaft clockwise to take up slack on right side of chain. Force left side of chain outward and measure distance between reference point and chain. Deflection is the difference between the 2 measurements. If deflection exceeds  $\frac{1}{2}$ " (12.7 mm), replace timing chain and sprockets.

### Removal

Disconnect fuel pump outlet line at pump. Remove fuel pump and position aside. Crank engine over until timing marks are aligned. See Fig. 17. Remove camshaft sprocket bolt, washer and 2-piece fuel pump eccentric. Remove both sprockets and timing chain as an assembly.

**Fig. 17: Aligning Timing Marks on Sprockets**

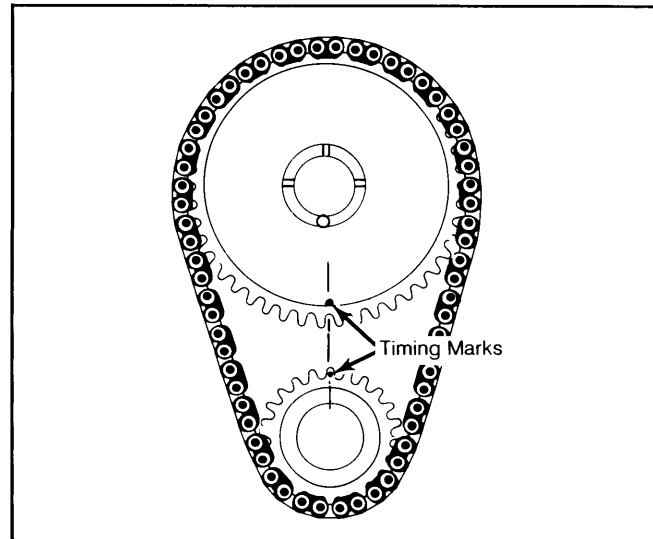

Remove and install chain and sprockets as an assembly.

### Installation

1) Position timing chain on sprockets, aligning timing marks as shown in Fig. 17. Slide timing chain and sprockets onto camshaft and crankshaft as an assembly.

2) Install 2-piece fuel pump eccentric, washer and camshaft sprocket bolt. Be sure outer eccentric sleeve rotates freely. Tighten camshaft bolt. Reverse removal procedure to complete installation, using new gaskets where required.

### CAMSHAFT

#### Removal

1) Drain cooling system. Disconnect upper and lower radiator hoses at radiator. Disconnect oil cooler lines at radiator (if equipped). Remove radiator. If A/C equipped, discharge system and remove A/C condenser.

2) Remove engine front cover. Align timing marks on sprockets, and remove timing chain and sprockets. See Fig. 17. Ensure crankshaft does not turn. Remove intake manifold and rocker arm covers. Loosen rocker arm fulcrum bolts, and rotate rocker arms to one side.

3) Identify push rods for reinstallation in original locations, and remove. Identify lifters for reinstallation in original locations. Using hydraulic lifter puller tool, remove lifters.

4) Remove camshaft thrust plate. Carefully extract camshaft from engine. Use care to avoid damaging camshaft bearings or camshaft lobes. See Fig. 18.

# Ford V8 Engines

## 6.6 LITER V8 (Cont.)

**Fig. 18: Camshaft Assembly**

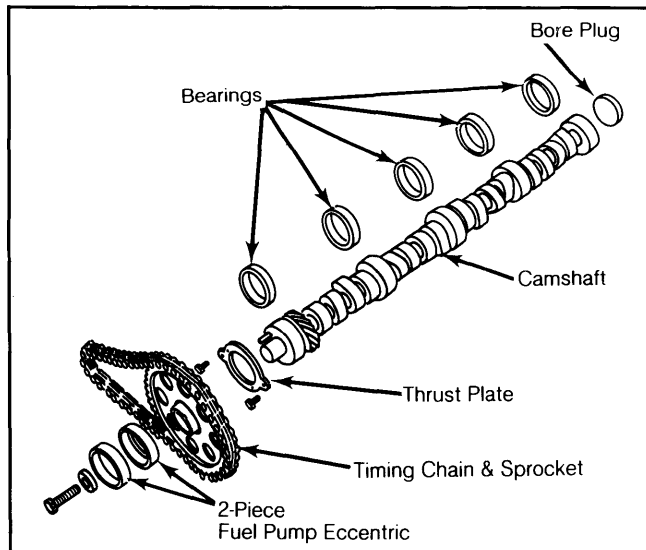

Remove and install camshaft with timing marks on sprockets aligned.

### Installation

Coat camshaft lobes with polyethelene grease (or equivalent), and bearing journals with heavy engine oil. With No. 1 piston still at TDC, carefully install camshaft in engine. Install thrust plate and tighten bolts. Install timing chain. To complete installation, reverse removal procedure.

### CAMSHAFT BEARINGS

#### Removal

Remove engine from vehicle. Remove flywheel, crankshaft, and camshaft. Push pistons to top of cylinder bores. Drive out camshaft rear bearing bore plug. Using camshaft bearing remover/installer tool, remove camshaft bearings.

#### Installation

1) Using bearing remover/installer tool, install new bearings into place. Make sure oil holes are aligned. Install front bearing .060" (1.52 mm) below front face of cylinder block. Install camshaft rear plug.

2) Replacement bearings are available in standard and .015" (.38 mm) undersize. Bearings are not interchangeable from one bore to another.

### CAMSHAFT END THRUST

**CAUTION:** Do not pry against camshaft sprocket without first relieving the valve train load on the camshaft.

1) Loosen rocker arm fulcrum bolts to relieve load on camshaft. Push camshaft toward rear of engine and install dial indicator. Position indicator point on camshaft sprocket attaching bolt. Zero dial indicator.

2) Place a large screwdriver between camshaft sprocket and cylinder block. Pull camshaft forward and release. If dial indicator reading shows excessive end play, replace thrust plate.

### CAM LOBE LIFT

1) Remove rocker arm cover, fulcrum bolt, fulcrum seat, rocker arm and fulcrum guide. Make sure

push rod end is in valve lifter socket. Install a remote starter switch to rotate crankshaft.

2) Use a dial indicator to check lobe lift in consecutive order. Position dial indicator point (or cup-shaped adapter) on end of push rod (in same plane as push rod movement). See Fig. 19.

**Fig. 19: Checking Cam Lobe Lift**

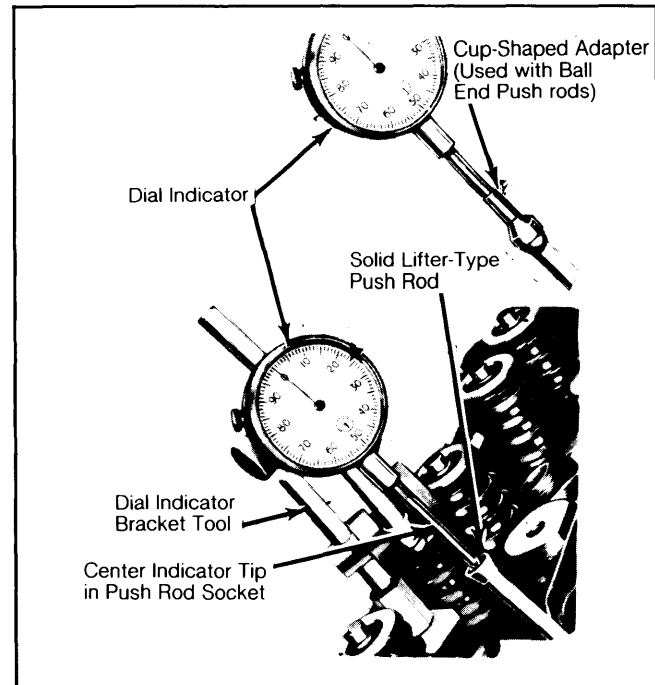

Make sure push rod end is in valve lifter socket.

3) Rotate crankshaft until lifter and push rod are at lowest position. Zero dial indicator. Rotate crankshaft slowly until push rod is in fully raised position. Record dial indicator reading and compare with specifications.

4) Maximum allowable lift loss is .005" (.13 mm). If lift on any lobe is below specifications, replace camshaft and valve lifter(s) operating on worn lobe(s).

## ENGINE OILING

### Crankcase Capacity

Capacity is 5 quarts (4.75L). Add 1 quart (.95L) with filter change.

### Oil Filter

Full-flow filter has an integral by-pass valve. An anti-drain back feature prevents reverse flow of oil when the engine is shut down. Replace filter at first oil change, then every second oil change thereafter.

### Normal Oil Pressure

50-75 psi (3.5-5.3 kg/cm<sup>2</sup>) at 2000 RPM.

### Pressure Regulator Valve

Valve located in pump body, not adjustable.

## ENGINE OILING SYSTEM

System is pressure fed from rotor-type oil pump. Oil flows through full-flow oil filter before entering main oil gallery. Oil from main gallery enters main bearings and camshaft bearings. Drilled oil holes in crankshaft provides lubrication to rod bearings.

## 6.6 LITER V8 (Cont.)

Oil moves through secondary drilled passages to lifters, where it is routed through hollow push rods up to top of head assembly to lubricate rocker arms. Oil is returned to oil pan through drain holes in cylinder heads. See Fig. 20.

**Fig. 20: Engine Oiling System**

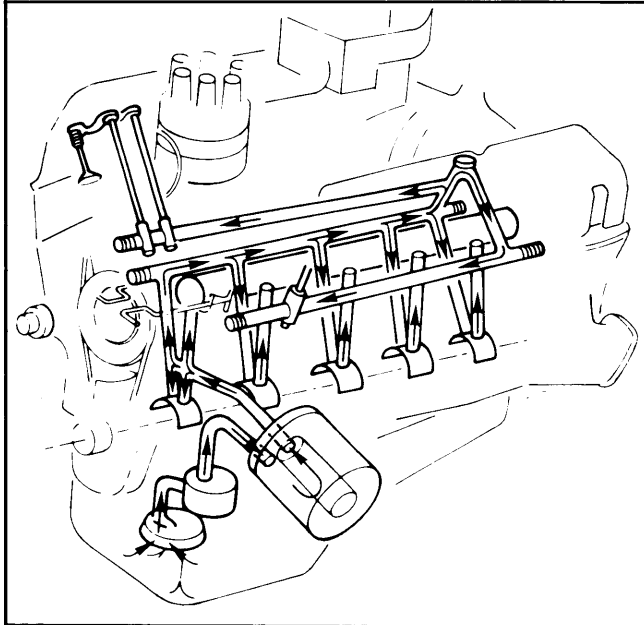

### OIL PUMP

#### Removal

Remove oil pan. Remove oil pump and pick up tube assembly, gasket and intermediate drive shaft.

#### Disassembly

Remove pick up tube assembly from pump. Remove pump cover. Remove inner rotor and shaft and outer rotor. Drill small hole in oil pressure relief valve cap. Insert self-threading sheet metal screw into cap, and pull cap from chamber. Remove spring and plunger. See Fig. 21.

**Fig. 21: Oil Pump Assembly**

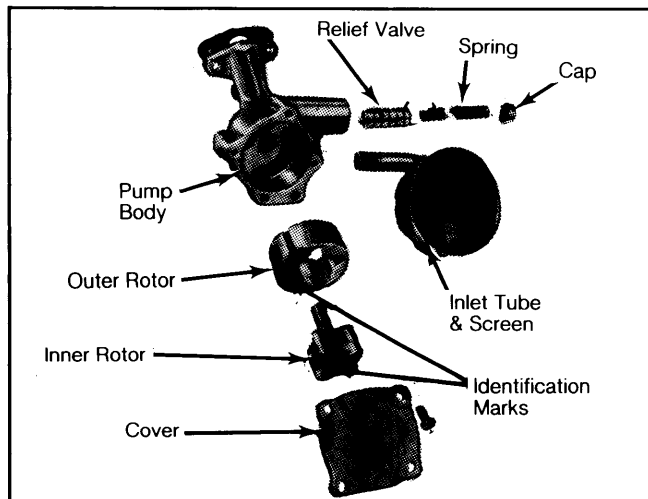

Identification mark on outer rotor must face same side as identification mark on inner rotor when installed.

**NOTE:** If any part of the oil pump requires replacement, the complete pump assembly must be replaced.

#### Inspection

1) Wash all parts thoroughly, and dry with compressed air. Check inside of pump housing, outer rotor, and inner rotor and shaft for damage, scoring or excessive wear. Check mating surface of pump cover for wear, scoring or grooved condition.

2) Remove rotor assembly from pump housing. Using feeler gauge, measure inner-to-outer rotor tip clearance. Install rotor assembly in pump housing. Lay a straightedge over rotor assembly and housing. Insert feeler gauge between straightedge and housing to measure rotor end play.

3) Measure outer rotor-to-housing clearance using feeler gauge. Measure the shaft outside diameter and the housing bearing inside diameter. Difference between readings is the shaft-to-housing bearing clearance.

4) Relief valve spring should test to 20.6-22.6 lbs. (9-10 kg) at 2.40" (63.2 mm). Inspect relief valve spring for worn or collapsed condition. Check relief valve plunger for scores and free operation in bore. Check clearance between relief valve plunger and bore.

### OIL PUMP SPECIFICATIONS

Application	Specifications In. (mm)
Rotor Tip Clearance	.012 (.30)
Rotor End Play	.004 (.10) Max.
Outer Rotor-to-Housing Clearance	.001-.013 (.03-.33)
Shaft-to-Housing Clearance	.0015-.0030 (.038-.076)
Relief Valve-to-Bore Clearance	.0015-.0030 (.038-.076)

#### Reassembly

Clean and oil all parts thoroughly. Install relief valve plunger, spring and new cap. Stake cap into position. Reassemble remaining components in reverse order of disassembly, using new gaskets where required.

#### Installation

1) Prime oil pump by filling either inlet or outlet port with engine oil. Rotate pump shaft to distribute oil within pump. Firmly seat intermediate drive shaft into distributor socket. The stop on the shaft should touch roof of crankcase. Reposition stop on shaft, if necessary.

2) Remove shaft and insert shaft into oil pump. Install and tighten shaft and pump as an assembly.

**CAUTION:** If pump and shaft do not readily seat, do not force into position. Realign drive shaft hex with distributor shaft socket, and reinstall.

## ENGINE COOLING

### WATER PUMP

#### Removal

Drain cooling system and disconnect battery. Remove fan shroud and position over fan. Remove all drive belts attached to water pump pulley. Remove fan,

# Ford V8 Engines

## 6.6 LITER V8 (Cont.)

spacer and pulley. If A/C equipped, remove lower idler pulley. Remove all mounting brackets and hoses attached to water pump. Remove water pump.

### Installation

Clean all gasket mating surfaces. Coat both sides of new pump gasket with gasket sealer. Position gasket on engine front cover. Coat water pump bolts with oil resistant sealer. Position pump on front cover, and install and tighten attaching bolts. Reverse removal procedure to install remaining components.

**NOTE:** For further information on cooling system capacities and other cooling system components, see appropriate article in "Engine Cooling Systems" at end of ENGINE Section.

### TIGHTENING SPECIFICATIONS

Application	Ft. Lbs. (N.m)
Camshaft Thrust Plate Bolts .....	9-12 (12-16)
Camshaft Sprocket Bolt .....	40-45 (54-61)
Connecting Rod Cap Nuts .....	40-45 (54-61)
Cylinder Head Bolts	
Step 1 .....	75 (102)
Step 2 .....	95-105 (129-142)
Engine Front Cover Bolts .....	12-18 (16-24)
Exhaust Manifold Bolts .....	18-24 (24-33)
Flywheel-to-Crankshaft Bolts .....	75-85 (102-115)
Intake Manifold	
$\frac{5}{16}$ " Bolts .....	19-25 (26-34)
$\frac{3}{8}$ " Bolts .....	22-32 (30-43)
Main Bearing Cap Bolts .....	95-105 (129-142)
Oil Filter Insert/Adapter .....	20-30 (27-40)
Oil Pump Attaching Bolts .....	22-32 (30-43)
Rocker Arm Cover Bolts .....	3-5 (4-7)
Rocker Arm Fulcrum Bolt .....	18-25 (24-34)
Vibration Damper Bolt .....	70-90 (95-122)
Water Pump Bolts .....	12-18 (16-24)

## ENGINE SPECIFICATIONS

### GENERAL SPECIFICATIONS

Year	Displ.		Carburetor	HP at RPM	Torque Ft. Lbs. @ RPM	Compr. Ratio	Bore		Stroke	
	cu. ins.	liters					in.	mm	in.	mm
1982	400	6.6	2-Bbl.	.....	.....	.....	4.00	101.6	4.00	101.6

### VALVES

Engine & Valve	Head Diam. In. (mm)	Face Angle	Seat Angle	Seat Width In. (mm)	Stem Diameter In. (mm)	Stem Clearance In. (mm)	Valve Lift In. (mm)
6.6L Int.	2.032-2.050 (51.61-52.07)	44°	45°	.080 (2.03)	.3423 (8.694)	.0010-.0027 (.025-.069)	.....
Exh.	1.659 (42.14)	44°	45°	.090 (2.29)	.3418 (8.682)	.0015-.0032 (.038-.081)	.....

### PISTONS, PINS, RINGS

Engine	PISTONS	PINS		RINGS		
	Clearance In. (mm)	Piston Fit In. (mm)	Rod Fit In. (mm)	Rings	End Gap In. (mm)	Side Clearance In. (mm)
6.6L	.0014-.0022 (.036-.056)	.0003-.0005 (.008-.013)	Interference Fit	1 & 2 3	.010-.020 (.25-.51) .010-.035 (.25-.89)	.003-.004 (.08-.10) Snug

# Ford V8 Engines

7-65

## 6.6 LITER V8 (Cont.)

### ENGINE SPECIFICATIONS (Cont.)

#### CRANKSHAFT MAIN & CONNECTING ROD BEARINGS

Engine	MAIN BEARINGS				CONNECTING ROD BEARINGS		
	Journal Diam. In. (mm)	Clearance In. (mm)	Thrust Bearing	Crankshaft End Play In. (mm)	Journal Diam. In. (mm)	Clearance In. (mm)	Side Play In. (mm)
6.6L	2.9994-3.0002 (76.185-76.205)	.0008-.0015 (.020-.038)	No. 3	.004-.008 (.10-.20)	2.3103-2.3111 (58.682-58.699)	.0008-.0015 (.020-.038)	.010-.020 (.25-.51)

#### CAMSHAFT

Engine	Journal In. (mm)	Clearance In. (mm)	Lobe Lift In. (mm)
6.6L <sup>1</sup>			
No. 1	2.1248 (53.970)	.001-.003 (.025-.076)	.250 (6.35)
No. 2	2.0665 (52.489)		
No. 3	2.0515 (52.108)		
No. 4	2.0365 (51.727)		
No. 5	2.0215 (51.346)		

#### VALVE SPRINGS

Engine	Free. Length In. (mm)	PRESSURE Lbs. @ In. (kg @ mm)	
		Valve Closed	Valve Open
6.6L			
Int.	2.06 (52.3)	76-84@1.82 (34-38@46.2)	215-237@1.39 (96-108@35.3)
Exh.	1.93 (49.0)	79-87@1.68 (36-39@42.7)	215-237@1.39 (96-108@35.3)

<sup>1</sup> — End play is .001-.006" (.03-.15 mm)