

5.0L & 6.0L V8 ENGINES

IDENTIFICATION CODING

ENGINE IDENTIFICATION

Engine code number located on tag attached to valve cover, right bank. Letter contained in code number designates CID, carburetor, and compression ratio. Coding is as follows:

Engine Identification Codes	
Application	Code
5.0L (304")	H
6.0L (360")	N

SPECIAL ENGINE MARKINGS

Some engines are produced at factory with oversize or undersize components. Letters found stamped adjacent to engine code number, indicate following deviation from standard specifications:

- B** – All cylinder bores .010" oversize.
- M** – All main bearings .010" undersize.
- F** – All connecting rod bearings .010" undersize.
- PM** – All connecting rod and main bearings .010" undersize.
- C** – All camshaft bearing bores .010" oversize.

ENGINE REMOVAL

See *Engine Removal* at end of *ENGINE* Section.

CYLINDER HEAD & MANIFOLD

INTAKE MANIFOLD

Removal – 1) Drain cooling system and remove air cleaner. Disconnect spark plug wires, upper radiator hose and by-pass hose from manifold. Remove ignition wire plastic separators from rocker arm cover brackets. Disconnect and move out of way temperature sending unit wire and ignition coil assembly.

2) Disconnect heater hose from rear of manifold. Mark all hoses, pipes and wires on carburetor, then disconnect them and place out of way. Disconnect throttle valve and linkage from carburetor and manifold. Disconnect air hoses from air injection manifolds.

3) Disconnect diverter valve from air pump. Remove carburetor. Remove intake manifold bolts, manifold, metal gaskets and end seals. Make sure gasket mating surfaces are clean and that gasket material does not fall into intake or exhaust ports of cylinder heads.

Installation – 1) Coat both sides of new metal gaskets with non-hardening sealant and attach gaskets to cylinder head locating studs. Apply Permatex No. 2 to seal ends and install them to engine block.

2) Install intake manifold and bolts to engine. Make sure all bolts are seated before tightening. Install diverter valve and attach air pump output hose. Connect air hoses to air injection manifolds. Connect all hoses, pipes, wires and linkages to carburetor and manifold.

3) Install ignition coil and bracket assembly. Connect upper radiator hose and bypass hose. Install ignition wire plastic separators, then connect spark plug wires. Install air cleaner assembly and add coolant.

CYLINDER HEAD

Removal – 1) Disconnect battery ground. Drain cooling system and remove rocker arm cover, rocker arm assemblies and push rods. Disconnect spark plug wires and remove spark plugs. Remove intake manifold and exhaust manifold.

NOTE – Keep rocker arm assemblies and push rods in same order as removed.

2) Loosen all drive belts and remove compressor mount bracket and battery negative cable from cylinder head. Disconnect alternator support brace, air pump, and power steering pump mount bracket from cylinder head. Remove retaining bolts and remove cylinder head and gasket.

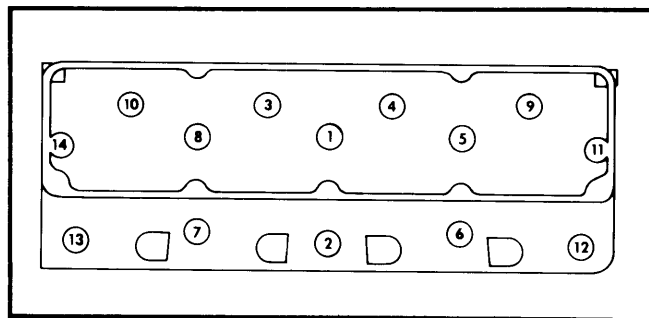

Fig. 1 Cylinder Head Tightening Sequence

Installation – 1) Clean all gasket surfaces. Apply a thin coat of sealing compound to both sides of head gaskets.

2) Position gasket on block with stamped word "TOP" facing up. Install cylinder head and retaining bolts. Tighten bolts in sequence. To complete cylinder head installation, reverse removal procedure. See Fig. 1.

NOTE – DO NOT apply sealing compound on head and block surfaces or allow sealer to enter cylinder bores.

VALVES

VALVE ARRANGEMENT

All – E-I-I-E-E-I-I-E (front to rear, both banks).

VALVE GUIDE SERVICING

Guides are an integral part of cylinder head and cannot be replaced. If valve guide is out of round more than .0025" or if valve guide bore is worn more than .003", valve guides must be reamed to next oversize and oversize valves installed. Oversize valves are available in .003", .015" and .030" oversize. Valve guide reamers are available for these oversizes.

NOTE – Guides must be reamed in steps, starting with .003" oversize reamer and progressing to size desired.

VALVE STEM OIL SEALS

Nylon valve stem seals are used on each valve stem and should be replaced whenever seals become deteriorated or valve service is performed. Use a 7/16" deep socket and light mallet to seat valve seals on stems.

5.0L & 6.0L V8 ENGINES (Cont.)

VALVE SPRINGS

Removal – 1) Remove rocker arm cover, rocker arm assemblies and push rods. Remove spark plug on cylinder to be serviced and install suitable air line adaptor to spark plug port. Apply air pressure to hold valves in place.

NOTE – Retain rocker arm assemblies, push rods, bridge and pivot assemblies in order of removal for reinstallation in original location.

2) Using suitable spring compressor (J-22534-1,4 & 5), compress valve spring and remove valve keeper locks. Remove valve spring and retainer. Remove and discard oil seal.

Installation – Use suitable valve spring tester (J-8056) to test valve springs. Replace those that are not within specifications. Reverse removal procedures while noting following: Valve springs must be installed with closed coil end facing cylinder head. Do not overcompress spring upon installation as damage may result to oil deflector. Push rods and rocker arm assemblies must be reinstalled in original locations.

ROCKER ARM ASSEMBLY

Rocker arms pivot on a bridged pivot assembly which is secured to cylinder head by cap screws. It is not normal to find a pattern along the length of the push rod. Check cylinder head for obstruction if this condition exists. If valve contact surface on rocker arm is worn severely, rocker arm must be replaced.

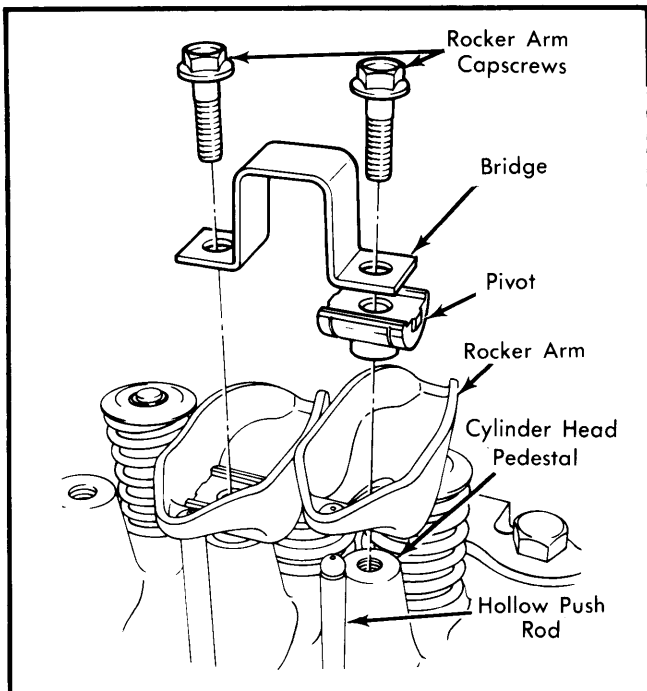

Fig. 2 Rocker Arm Assembly

HYDRAULIC VALVE LIFTER ASSEMBLY

Lifters are serviced as complete assemblies only and parts are not interchangeable between lifters. Inspect for signs of scuffing on barrel and face of tappet body. Inspect face for concave wear and if present, replacement of camshaft and tappet is necessary. If lifters are disassembled for cleaning and inspection, after reassembly they should be tested using suitable

leak-down tester according to manufacturers' instructions. Leak-down should take 20-110 seconds with a load travel of .125". Discard tappets not within specifications.

NOTE – DO NOT fill tappet assemblies with engine oil prior to installation as they will charge themselves within 3-8 minutes of engine operation.

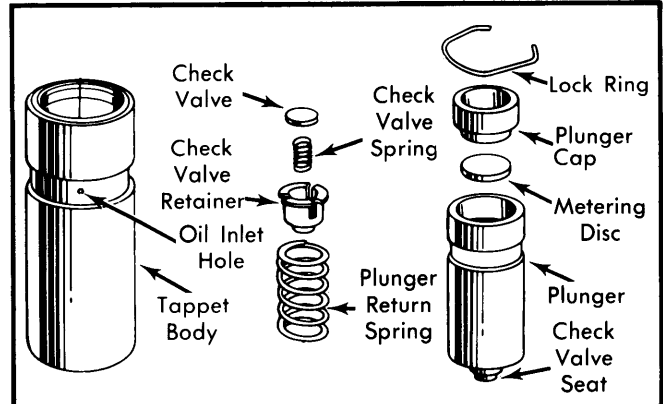

Fig. 3 Exploded View of Hydraulic Valve Lifter Assembly

PISTONS, PINS & RINGS

OIL PAN

See Oil Pan Removal at end of ENGINE Section.

PISTON & ROD ASSEMBLY

NOTE – New pistons must be installed in same cylinders for which they were fitted and used pistons in same cylinder from which they were removed.

Removal – 1) With cylinder head and oil pan removed, use a suitable ridge reamer to remove any ridge or deposits on upper end of cylinder bore.

NOTE – Piston must be at bottom of stroke and covered with cloth to collect cuttings.

2) Remove connecting rod bearing caps and retain in same order as removed. Cover connecting rod studs to protect cylinder walls and push piston and rod assembly out top of block.

NOTE – Caps and rods are stamped with corresponding cylinder number.

Installation – 1) Piston rings must be positioned as follows: No. 1 compression ring gap must be 180° from No. 2 compression ring gap. Oil control ring spacer expander gap must be at least 90° from No. 2 compression ring gap. Oil control ring gaps must be 90° from expander gap with at least 30° between each ring gap. Upper and lower compression ring markings indicate top side of ring.

2) Lightly coat pistons, rings and cylinder walls with engine oil. Install suitable ring compressor on pistons making certain ring gap positions do not change. With connecting rod studs covered for cylinder wall protection, install each piston and rod assembly (with notch on piston head towards front of engine) in its respective bore. Guide connecting rod onto crankshaft journal while tapping piston head with hammer handle to seat connecting rod against crankshaft. Install mating rod cap, nuts and tighten to specifications.

5.0L & 6.0L V8 ENGINES (Cont.)

NOTE — With pistons installed, cylinder number should be outboard and squirt hole inboard.

FITTING PISTONS

Measure cylinder bore diameter $2\frac{5}{16}$ " below top of cylinder bore. Measure piston at right angles to piston pin at centerline of pin. If clearance is not within specifications, replace piston.

PISTON PINS

Removal — Place piston on support tool (J-21872-1) and use removal tool (J-21872), press piston pin out with arbor press. Note position of pin through gauge window of remover support.

Installation — Using pilot tool (J-21872-2), and support (J-21872-1), press piston pin through connecting rod and piston until pin pilot indexes with mark on support. Pin should be centered in rod $\pm\frac{1}{32}$ ".

NOTE — If little effort is required to install piston pin in connecting rod, or if rod moves along pin, a new connecting rod is required. Check piston for freedom of movement on pin.

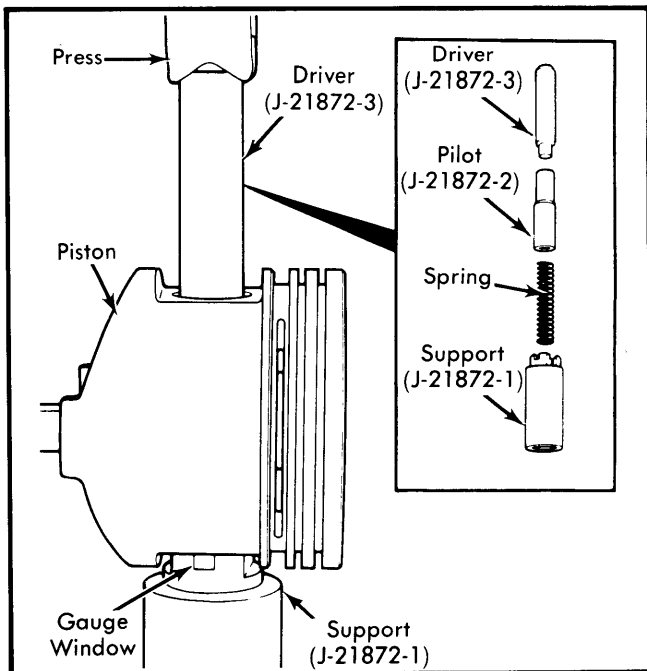

Fig. 4 Piston Pin Removal & Installation

MAIN & CONNECTING ROD BEARINGS

NOTE — Following procedure is with oil pan removed.

Connecting Rod Bearings — 1) After ensuring rod caps are marked for cylinder identification, remove rod caps. Use Plastigage method to check for proper bearing clearances. If not within specifications, new bearings must be installed. New bearings are available in standard and .001", .002", .010" and .012" undersize.

2) Selective fitting is required on each connecting rod. A standard bearing may be used in combination with a .001" under-

size, or a .002" undersize in combination with a .001" undersize. Coat bearing surfaces with oil, install rod cap, nuts and tighten to specifications.

NOTE — Never use a new bearing with a used bearing. Never use a pair of bearings with more than .001" difference in size on same journal.

Main Bearings — 1) Support crankshaft at counterweight adjacent to main bearing being checked and ensure that all bearing caps other than one being checked are tight. Starting with rear main bearing cap and working forward, remove one cap at a time and check bearing clearances, using Plastigage method.

2) If clearances are not within specifications, bearings are available in standard and .001", .002", .010" and .012" undersize. A standard bearing may be used in combination with a .001" undersize, or a .002" undersize in combination with a .001" undersize.

NOTE — Never use a new bearing with a used bearing. Never use a pair of bearings with more than .001" difference in size on same journal.

3) Remove all upper bearings by inserting suitable tool in oil hole of crankshaft journal and rotating crankshaft clockwise to roll bearing from engine. Oil new bearing and rotate crankshaft so bearing will rotate in direction of its locating tang. Install bearing cap with lower bearing and tighten bolts.

THRUST BEARING ALIGNMENT

When replacing thrust bearings (located at No. 3 main bearing journal), crankshaft should be moved fore and aft to align thrust faces of bearings.

REAR MAIN BEARING OIL SEAL

Removal — Remove oil pan and rear main bearing cap. Loosen all remaining main bearing bolts. Using a brass drift, tap upper seal until it is protruding enough to permit pulling it out completely. Remove lower seal from bearing cap.

Installation — Reverse removal procedure while noting the following: Lips of seal must face toward front of engine. Ensure seal is firmly seated in bearing cap recess. Use suitable sealer.

CAMSHAFT

FRONT COVER

Removal — 1) Drain cooling system and disconnect radiator hoses and by-pass hose. Remove drive belts, fan and hub assembly, distributor, fuel pump, drive pulley and vibration damper. Remove A/C compressor and power steering pump without disconnecting hoses and position on one side.

2) Remove alternator and mounting bracket from engine. Remove 2 front oil pan bolts. Remove bolts securing front cover to block. Pull cover forward until free of locating dowel pins.

NOTE — Bolts vary in length and must be installed in same location as removed.

5.0L & 6.0L V8 ENGINES (Cont.)

Installation – 1) Remove lower locating dowel pin from engine block and clean all gasket surfaces. Cut both sides of oil pan gasket flush with engine block. Using old gasket as a guide, trim new gasket to correspond to amount cut off at oil pan. Apply suitable sealer to both sides of gasket and install on front cover.

2) Install front oil pan seal and align tongues of new oil pan gasket pieces with seal and cement into place on cover. Apply suitable sealer to cut-off edges of original oil pan gaskets and place cover into position, then install 2 front oil pan bolts.

3) Tighten bolts slowly and evenly until cover aligns with upper locating dowel. Install lower dowel through cover and drive into corresponding hole in engine block. Install cover retaining bolts in same location as they were removed from and tighten.

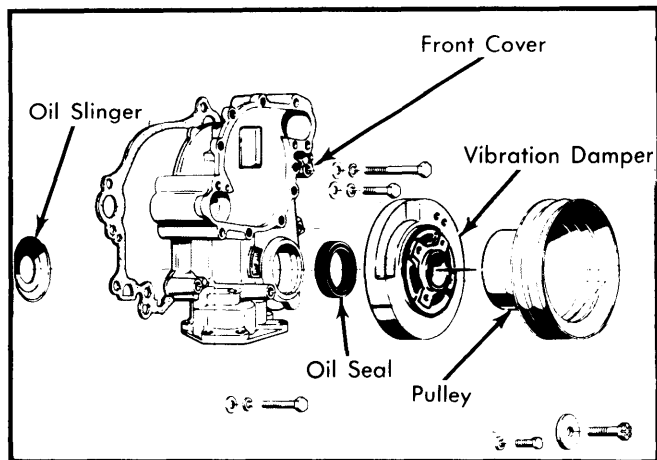

Fig. 5 Exploded View of Engine Front Cover

FRONT COVER OIL SEAL

Removal – The oil seal may be installed from either side of the front cover. It is not necessary to remove cover for seal replacement. Use removal tool (J-9256) to remove seal.

Installation – Clean seal bore and apply light coat of suitable sealer to outer surface of new seal. Drive new seal into place using tool (J-26562), until seal contacts outer flange of cover. Apply light coat of engine oil to lip of neoprene seal.

TIMING CHAIN

Removal – Remove front cover and crankshaft oil slinger. Remove camshaft sprocket retaining bolt and washer, distributor drive gear and fuel pump eccentric. Rotate crankshaft until timing mark on sprocket is aligned with camshaft sprocket timing mark. See Fig. 6. Remove crankshaft sprocket, camshaft sprocket and timing chain as an assembly.

Installation – 1) Assemble timing chain, crankshaft sprocket and camshaft sprocket with timing marks aligned. Install fuel pump eccentric and distributor drive gear. See Fig. 7.

NOTE – Fuel pump eccentric must be installed with stamped word "REAR" facing camshaft sprocket.

2) Install camshaft sprocket washer and retaining bolt. Check for correct installation of timing chain by rotating crankshaft until timing mark on camshaft sprocket is at 3 o'clock position.

Beginning with pin next to camshaft sprocket timing mark, ensure that the crankshaft timing mark lies between pins 20 and 21. Install oil slinger, new cover gasket and front cover.

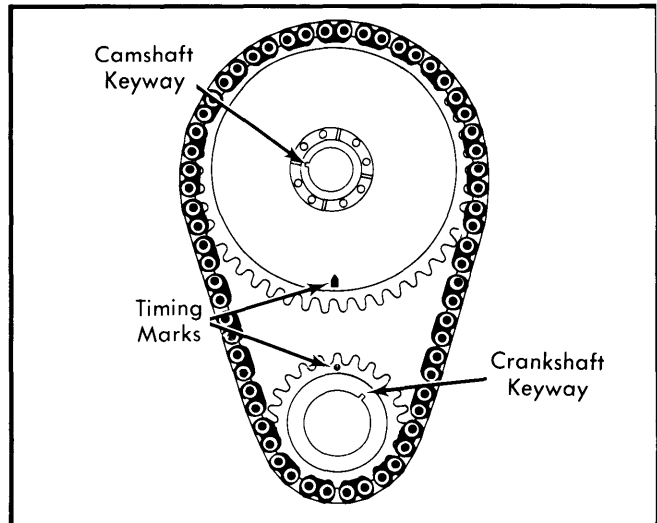

Fig. 6 Aligning Timing Marks

CAMSHAFT

Removal – 1) Drain cooling system and remove radiator assembly. Remove air conditioning condenser and receiver assembly (without disconnecting hoses) and position to one side. Remove rocker arm cover, rocker arm assemblies and push rods. Remove intake manifold and hydraulic lifters.

NOTE – Retain rocker arm assemblies, push rods and lifters in order for reinstallation in original location.

2) Remove front cover and rotate crankshaft until timing mark on sprocket is aligned with camshaft sprocket timing mark. See Fig. 6. Remove crankshaft sprocket, camshaft sprocket, and timing chain as an assembly. Remove hood latch support bracket upper retaining screw and move bracket (as required) for access to camshaft. Remove front bumper or grille (as required) and carefully remove camshaft.

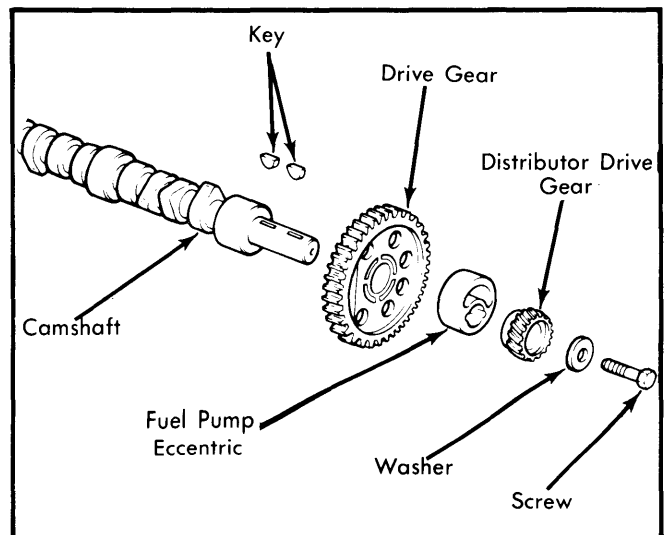

Fig. 7 Exploded View of Camshaft Assembly

5.0L & 6.0L V8 ENGINES (Cont.)

Installation — Reverse removal procedure while noting following: Lubricate camshaft with suitable oil supplement and install camshaft carefully to avoid damage to camshaft lobes.

CAMSHAFT BEARINGS

NOTE — When installing bearings, use a screw-type cam bearing installation tool, one that provides steady pressure. DO NOT use a driver-type cam bearing installation tool.

CAM LOBE LIFT

Remove rocker arm cover, bridged pivot, rocker arms and spark plugs, then proceed as follows:

1) Use suitable clamping or mounting fixture, attach dial indicator to cylinder head so indicator probe rests on top of push rod with indicator and probe in a vertical position over push rod. Rotate crankshaft slowly until valve lifter is on heel of cam lobe. At this point, push rod will be at its lowest position.

CAUTION — If using an auxiliary starter switch, distributor primary lead must be disconnected from negative post of coil.

2) With push rod at lowest position, zero dial indicator and rotate engine until push rod is in fully raised position. Compare total lift recorded, with specifications. Check all remaining lobes of camshaft in same manner.

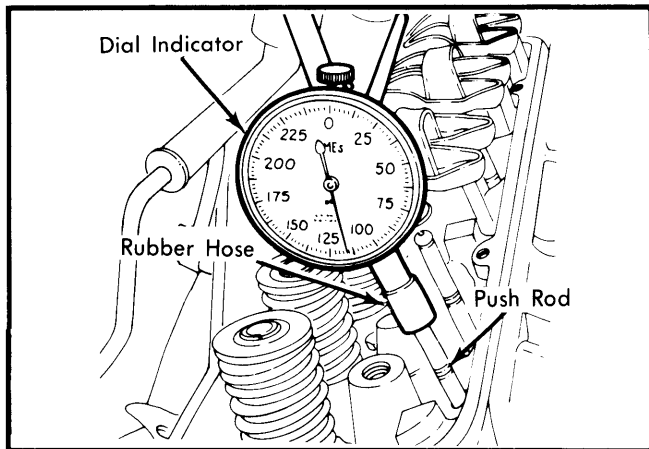

Fig. 8 Measuring Camshaft Lobe Lift

VALVE TIMING

1) Remove spark plugs, rocker arm covers, and rocker arm assemblies from No. 1 cylinder. Rotate crankshaft until No. 6 piston is at TDC on compression stroke and rotate crankshaft counterclockwise 90° from this position. Install a dial indicator on No. 1 intake valve rocker arm push rod end. Set dial indicator to zero.

2) Crank engine slowly in clockwise direction until dial indicator shows a lift of .020". Timing marks on vibration damper should be in line with TDC or zero marking on timing chain cover. If variation of more than 1/2" in either direction exists, remove timing chain cover and inspect timing chain installation.

ENGINE OILING

Crankcase Capacity — 4 quarts. Add 1 quart with filter change.

Oil Filter — Replace oil filter every 5000 miles or 5 months, whichever comes first.

Normal Oil Pressure — 13 psi minimum at 600 RPM and 37-75 psi maximum at 1600+ RPM.

Pressure Regulator Valve — Located in pump body. Not adjustable.

ENGINE OILING SYSTEM

Oil is drawn from oil pan into gallery at lower right side of engine. A passage in timing chain cover channels oil into oil pump. Oil then flows through oil filter equipped with by-pass valve and to gallery extending to left front of engine. Oil passes directly to right main gallery and intersects with short passage leading to left main gallery. Engine components are then lubricated as follows:

Crankshaft & Camshaft Bearings — Passages extend down from main oil galleries to each camshaft bearing and to each upper main bearing. Passages in crankshaft allow oil flow from main bearing journal to adjacent connecting rod journal. A squirt hole in connecting rod bearing cap distributes oil on cylinder walls, pistons and piston pins.

Hydraulic Valve Lifters — Lubricated directly from main oil galleries.

Rocker Arms & Push Rods — Oil is delivered from hydraulic lifters and passes through hollow push rods to rocker arms. Rocker arms direct oil onto valve train and oil returns to pan through channels in cylinder head.

Timing Chain & Sprockets — Oil is received from front camshaft bearing. Oil is thrown off to lubricate distributor gear and fuel pump eccentric. Oil returns to pan through cavity under front main bearing.

OIL PUMP

Oil pump is driven by distributor drive shaft. Removal of pump will not affect ignition timing, as distributor gear remains in time with camshaft. Pump must be filled with petroleum jelly (do not use grease of any type) prior to installation of oil pump cover. To measure oil pump gear clearances, proceed as follows:

1) To measure pump gear end clearance, two methods can be used; Plastigage method (preferred) and feeler gauge method (alternate). To use the Plastigage method, remove pump cover and gasket. Place a strip of Plastigage across each gear end and install pump cover with gasket. Tighten screws to 55 INCH lbs. Remove screws, cover and gasket. Measure Plastigage width for correct specifications.

2) To use feeler gauge method, remove pump cover and gasket. Place a straight edge across pump body and gear ends. Insert a feeler gauge that fits snug and check feeler gauge thickness against specifications.

3) To check pump housing to gear tooth clearance, insert feeler gauge that fits snug between gear tooth and pump body. Check feeler gauge thickness against specifications.

Oil Pump Specifications

Application	Specifications
Gear-to-Body Clearance0005-.0025"
Gear End Clearance	
Plastigage Method002-.008"
Feeler Gauge Method004-.008"

Jeep V8 Engines

5.0L & 6.0L V8 ENGINES (Cont.)

ENGINE SPECIFICATIONS

GENERAL SPECIFICATIONS							
Year	Displ. Cu. Ins.	Carburetor	HP at RPM	Torque (Ft. Lbs. at RPM)	Compr. Ratio	Bore	Stroke
1981							
5.0L ¹	304"	2-Bbl.	8.4:1	3.75"	3.44"
6.0L	360"	2-Bbl.	8.25:1	4.08"	3.44"

VALVES							
Engine & Valve	Head Diam.	Face Angle	Seat Angle	Seat Width	Stem Diameter	Stem Clearance	Valve Lift
5.0L Int.	1.782-1.792"	29°	30°	.040-.060"	.3715-.3725"	.001-.003"	.426"
5.0L Exh.	1.401-1.411"	44°	44.5°	.040-.060"	.3715-.3725"	.001-.003"	.426"
6.0L Int.	2.020-2.030"	29°	30°	.040-.060"	.3715-.3725"	.001-.003"	.426"
6.0L Exh.	1.675-1.687"	44°	44.5°	.040-.060"	.3715-.3725"	.001-.003"	.426"

PISTONS, PINS, RINGS						
Engine	PISTONS		PINS		RINGS	
	Clearance	Piston Fit	Rod Fit	Rings	End Gap	Side Clearance
5.0L	.001-.0018"	.0003-.0005"	Press Fit	1 & 2 3	.010-.020" .010-.025"	.0015-.003" ① .001-.008"
6.0L	.0012-.002"	.0003-.0005"	Press Fit	1 & 2 3	.010-.020" .015-.045"	.0015-.003" ② 0-.007"

① — Ring No. 1 side clearance is .0015-.0035".

② — Ring No. 2 side clearance is .0015-.0035".

CRANKSHAFT MAIN & CONNECTING ROD BEARINGS							
Engine	MAIN BEARINGS				CONNECTING ROD BEARINGS		
	Journal Diam.	Clearance	Thrust Bearing	Crankshaft End Play	Journal Diam.	Clearance	Side Play
5.0L, 6.0L	①2.7474-2.7489"	②.001-.003"	No. 3	.003-.008"	2.0934-2.0955"	.001-.003"	.006-.018"

① — For bearings 1-4. No. 5 bearing 2.7464-2.7479".

② — For bearings 1-4. No. 5 bearing .002-.004".

MAIN BEARING FITTING CHART		
Main Bearing Journal Color Code & Diameter	Bearing Color & Size Code	
	Upper Insert	Lower Insert
Yellow 2.7484-2.7489"	Yellow Std.	Yellow Std.
Orange 2.7479-2.7484"	Yellow Std.	Black -.001"
Black 2.7474-2.7479"	Black -.001"	Black -.001"
Green 2.7469-2.7474"	Black -.001"	Green -.002"
Red 2.7384-2.7389"	Red -.010"	Red -.010"

CONNECTING ROD FITTING CHART		
Connecting Rod Journal Color Code & Diameter	Bearing Color & Size Code	
	Upper Insert	Lower Insert
Yellow 2.0948-2.0955"	Yellow Std.	Yellow Std.
Orange 2.0941-2.0948"	Yellow Std.	Black -.001"
Black 2.0934-2.0941"	Black -.001"	Black -.001"
Red 2.0848-2.0855"	Red -.010"	Red -.010"

Jeep V8 Engines

5.0L & 6.0L V8 ENGINES (Cont.)

ENGINE SPECIFICATIONS (Cont.)

CAMSHAFT			
Engine	Journal Diam.	Clearance	Lobe Lift
5.0L, 6.0L		.001-.003"	.266"
No. 1	2.1195-2.1205"		
No. 2	2.0895-2.0905"		
No. 3	2.0595-2.0605"		
No. 4	2.0295-2.0305"		
No. 5	1.9995-2.0005"		

VALVE SPRINGS			
Engine	Free Length	PRESSURE (LBS.)	
		Valve Closed	Valve Open
5.0L, 6.0L	1.99"	64-72@1.786"	202-220@1.356"

VALVE TIMING				
Engine	INTAKE		EXHAUST	
	Open (BTDC)	Close (ABDC)	Open (BBDC)	Close (ATDC)
5.0L, 6.0L	14.75°	68.75°	56.75°	26.75°

TIGHTENING SPECIFICATIONS	
Application	Ft. Lbs.
Cylinder Head Bolts	110
Intake Manifold Bolts	43
Exhaust Manifold Bolts	
Center (2)	25
Outer (4)	15
Oil Pan Bolts	
1/4"	7
5/16"	11
Main Bearing Cap Bolts	100
Connecting Rod Nuts	33
Flywheel-to-Crankshaft Bolts	105
Vibration Damper BoltⓄ	90
Camshaft Sprocket Bolt	30
Rocker Arm Cap Screws	19
Engine Front Cover Bolts	25
Thermostat Housing Bolts	13
A.I.R.Tube-to-Manifold Nuts	38
Oil Pump Cover Bolts	5
Oil Relief Valve Cap	28
Water Pump Bolts	4
Ⓞ — Bolt is lubricated.	