

## 5.7L V8 DIESEL ENGINE

## IDENTIFICATION CODING

## ENGINE IDENTIFICATION

Engines may be identified by codes found stamped on pad at lower left front side of cylinder block. An alternate location for engine codes is lower left rear side of cylinder block (just above starter). Code letters are suffix of engine Identification Number.

Engine Identification Codes	
Application	Code
5.7L (350") Diesel	
Federal .....	VLC
Calif. ....	VLD

## ENGINE REMOVAL

See *Engine Removal* at end of *ENGINE* Section.

## CYLINDER HEAD &amp; MANIFOLDS

## INTAKE MANIFOLD

**Removal** – 1) Drain cooling system, remove air cleaner and disconnect all hoses and wiring as necessary. Remove breather pipes and air crossover. Cap intake manifold with cover screens (J-26996-2 for Calif. or J-26996-10 for Federal).

2) Disconnect throttle rod, spring and remove retaining clip from bellcrank. Remove throttle cable from bracket and position away from engine. Remove alternator and A/C bracket as necessary.

3) Disconnect fuel lines to fuel pump, filter, nozzles and injection pump. Remove injection pump, fuel filter and brackets. Cap all open fuel lines and fittings.

4) Remove vacuum pump, drain tube, intake manifold and injection pump adapter.

**CAUTION** – DO NOT bend injection pump lines.

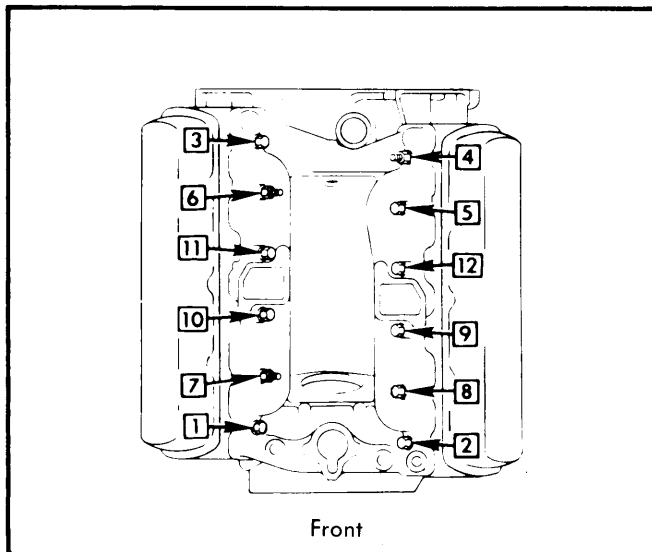

Fig. 1 Intake Manifold Tightening Sequence

**Installation** – 1) Clean machined surfaces of manifold and head. Use suitable sealer to coat both sides of intake manifold gasket and position on head. Install end seals and intake manifold making sure that ends are positioned under cylinder head. Before installing bolts, connect thermostat bypass hose to water hose.

2) Dip manifold bolts in oil and tighten in 2 steps. See Fig. 1. Install drain tube and apply chassis lube to seal area on injection pump adapter, taper edge and seal area of manifold. Use seal installing tool (J-28425) to properly position seal on adapter, then tighten bolts to specifications.

**NOTE** – When replacing original injection pump with new pump, only use injection pumps with part number 22510362 for Federal vehicles or injection pumps with part number 22510363 for Calif. vehicles.

3) Align offset tang on pump drive shaft with offset in pump driven gear and install injection pump. Align mark on injection pump with mark on adapter. Install fuel filter bracket and fuel filter. Connect fuel lines and fuel return line to injection pump.

4) Install vacuum pump and vacuum lines, then reverse removal procedure to complete installation.

## EXHAUST MANIFOLD

**Removal** – Remove air cleaner and lower alternator bracket. Raise vehicle, remove crossover pipe and disconnect exhaust pipe from manifold. Remove right side manifold. Lower vehicle and remove left side manifold.

**Installation** – To install manifolds, reverse removal procedure.

## CYLINDER HEAD

**Removal** – 1) Drain cooling system and remove or disconnect all necessary lines, hoses, brackets and linkage. Remove intake and exhaust manifolds. Remove rocker arm assemblies and push rods.

**NOTE** – Keep rocker arms, pivots and push rods in order of removal. They must be installed in their original positions.

2) Remove engine block drain plug on same side as cylinder head being removed. Remove cylinder head bolts and cylinder head. If necessary to remove pre-chamber, remove the glow plug and injection nozzle, then tap out with a small blunt drift punch.

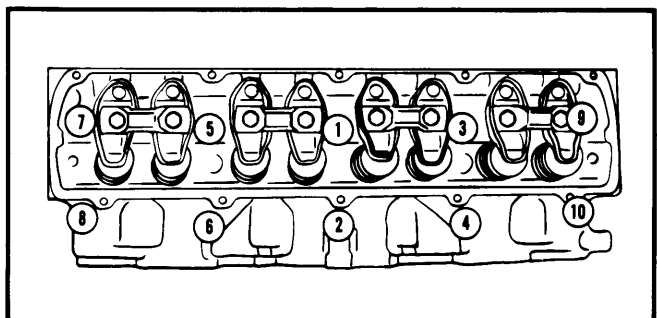

Fig. 2 Cylinder Head Tightening Sequence

## 5.7L V8 DIESEL ENGINE (Cont.)

**Installation** — 1) Install head gasket WITHOUT sealer. Install pre-chamber (if removed) to the head. Pre-chamber must not be recessed or protrude more than .003". Install glow plug, injection nozzle, and head to engine block.

**NOTE** — On early 1981 diesel engines the head gasket can be installed upside down. To prevent this, later models have a 3rd dowel pin in engine block. On early models, install head gasket with the prechamber shield (on gasket) facing toward cylinder head.

2) Clean and dip cylinder head bolts in engine oil and tighten in 2 steps. See Fig. 2.

### VALVES

#### VALVE ARRANGEMENT

I-E-I-E-E-I-E-I (Both banks, front to rear)

#### VALVE GUIDE SERVICING

Intake and exhaust valve guides are integral with cylinder head. Valves are available in Standard, .003", .005", .010" and .013" oversize.

**NOTE** — Use .003" oversize reamer for Standard and .003" oversize valves. Use .005" oversize reamer for .005" oversize and .013" oversize reamer for .010" and .013" oversize valves.

#### VALVE STEM OIL SEALS

Install oil seal down as far as possible on valve stem. Seals will correctly position when engine is started. The valve stem oil seals are color coded as follows:

- Intake — Gray: Standard to .005" oversize.
- Orange: .010" to .013" oversize.
- Exhaust — Ivory: Standard to .005" oversize.
- Blue: .010" to .013" oversize.

#### VALVE SPRINGS

**Removal** — With cylinder head removed, remove valve keys using valve spring compressing tool (J-5892-1) to compress spring. Remove retainers, spring and seal. Keep components separate for reinstallation in original location.

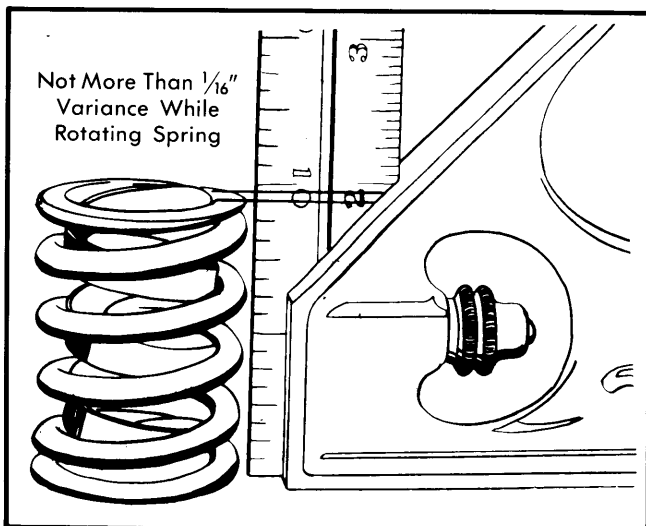
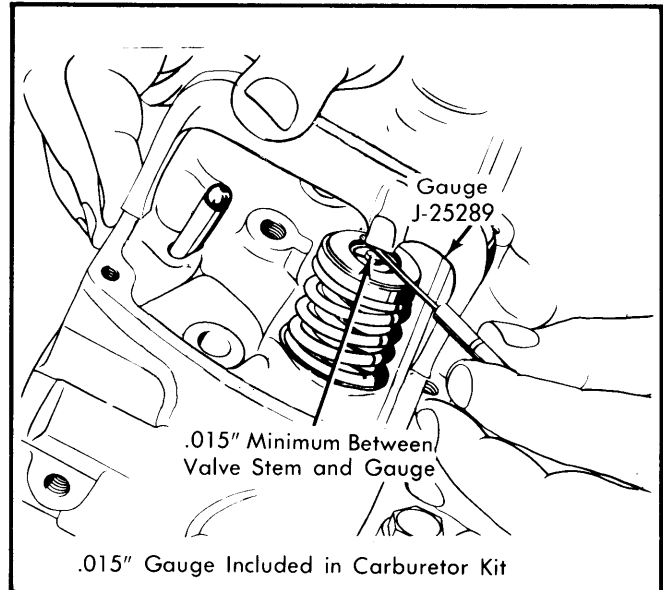

**Fig. 3 Checking Valve Spring Squareness**

**Inspection** — Check for squareness of valve spring as shown in Fig. 3. Spring must be within  $\frac{1}{16}$ " square in free position.

**Installation** — 1) Reverse removal procedure and note the following: Check spring and keys to be sure they are properly installed.

2) Measure valve stem height whenever new valve is installed or after grinding valve. Use valve stem height gauge (J-25289) shown in Fig. 4. There should be at least .015" clearance between gauge and valve stem. If clearance is less than .015", grind tip as required.



**Fig. 4 Measuring Valve Stem Height**

3) Measure clearance between gauge and valve rotator. Clearance must be .030" minimum. If any valve is less than .005" above rotator, valve is too short and must be replaced. See Fig. 5.

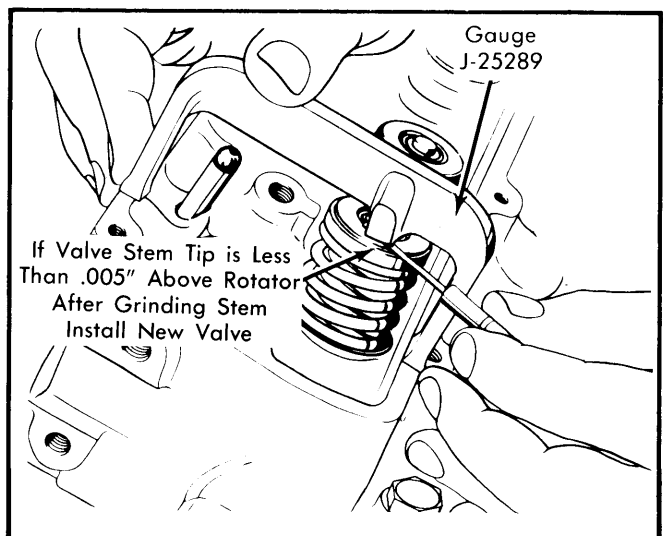

**Fig. 5 Measuring Rotator Height**

#### ROCKER ARM ASSEMBLY

**Removal & Installation** — Remove valve cover, rocker arm flanged bolts, pivot and rocker arms. Remove each set (one set

## 5.7L V8 DIESEL ENGINE (Cont.)

per cylinder) as a unit. To install, position one set of rocker arms in proper location. Lubricate wear points with suitable lubricant and install pivots. Install flanged bolts and tighten alternately to proper torque.

**NOTE** — Refer to "Valve Lifter Bleed Down" as lifters must be bled down to prevent piston from hitting valves.

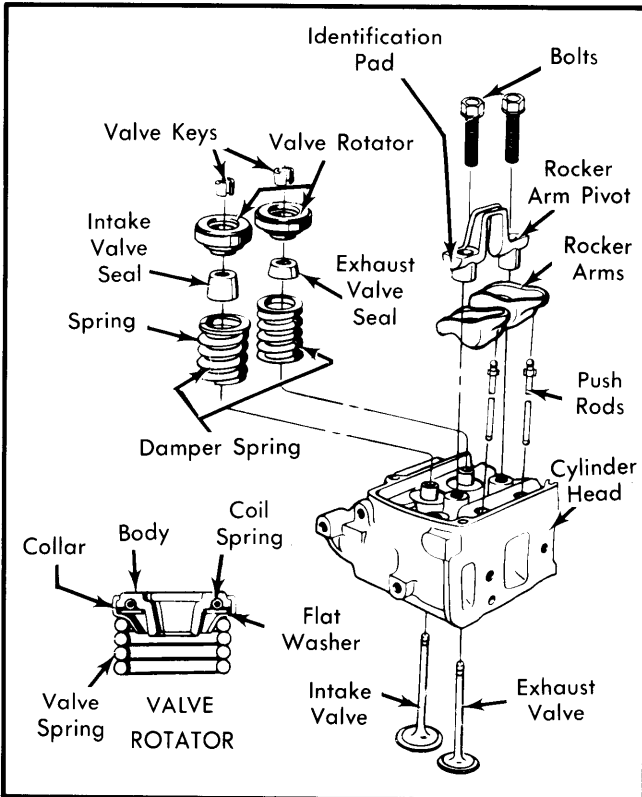

Fig. 6 Exploded View of Valve Assembly

## HYDRAULIC LIFTER ASSEMBLY

Hydraulic lifters used on the diesel engine are of the roller type. Lifters are serviced as complete assemblies only and parts are not interchangeable between lifters.

**NOTE** — If intake manifold was removed and if any rocker arm assembly was removed or loosened, the lifters affected **MUST** be removed, disassembled and oil drained out, then reassembled. Failure to do this could cause valve train damage.

**Disassembly** — With valve lifter removed from engine, remove retainer ring. Remove push rod seat and oil metering valve. Remove plunger and plunger spring. Remove check valve retainer from plunger and remove valve spring. See Fig. 7.

**Inspection** — Clean all parts in clean solvent or diesel fuel. Check for nicks, burrs or scoring on parts. Make sure lifter roller operates smoothly and without excessive play.

**Reassembly** — Coat all parts with clean engine oil, then reverse disassembly procedure.

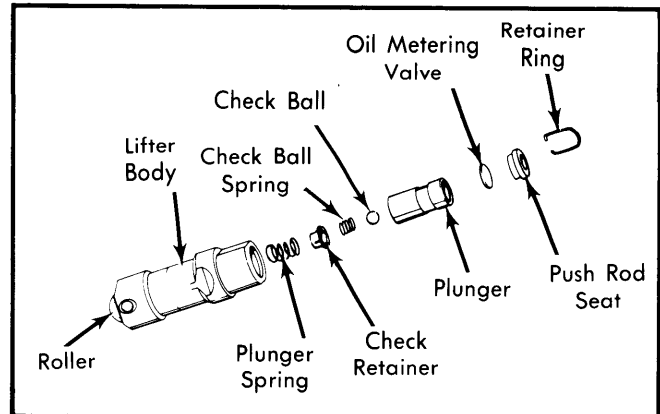

Fig. 7 Exploded View of Valve Lifter Assembly

**NOTE** — Oversize lifters are used and are identifiable by raised "O" on lifter bore casting on block. Oversize is .010".

## VALVE LIFTER BLEED DOWN

If intake manifold was not removed but some or all of the rocker arm assemblies were loosened or removed, proceed as follows:

1) Before installing any rocker arm assembly, rotate crankshaft until number 1 cylinder is 32° BTDC. This is 1/2" beyond end of timing indicator. Remove glow plug for number 1 cylinder to check correct positioning of crankshaft.

2) If removed or loosened, install number 5 cylinder rocker arm assembly first. Tighten rocker arm bolts evenly and alternately until exhaust valve just starts to open.

**CAUTION** — Do not tighten rocker arm assemblies, for cylinders 3, 5 and 8, beyond the point where valves are fully open or damage to valve train will occur.

3) Install remaining removed or loosened rocker arms. Tighten bolts until valves are in the fully open position. Then finish tightening rocker arm for cylinder number 5 until valve is in fully open position.

**CAUTION** — It will take approximately 45 minutes for lifters to bleed down. During this time, **DO NOT** rotate engine or damage to valve train and/or engine will occur.

## PISTONS, PINS &amp; RINGS

## OIL PAN

See Oil Pan Removal at end of ENGINE Section.

## PISTON &amp; ROD ASSEMBLY

**Removal** — 1) Remove intake manifold, heads, oil pan and oil pump. Mark rod and caps for reinstallation in same cylinder. Use ridge reamer to remove any deposits or ridge on upper end of cylinder bore.

**NOTE** — Pistons must be at bottom of stroke and covered with cloth to collect cuttings.

2) Remove rod cap and use guide hose over threads of rod bolts to prevent damage to journals and threads. Remove rod and pistons out top of block.

## 5.7L V8 DIESEL ENGINE (Cont.)

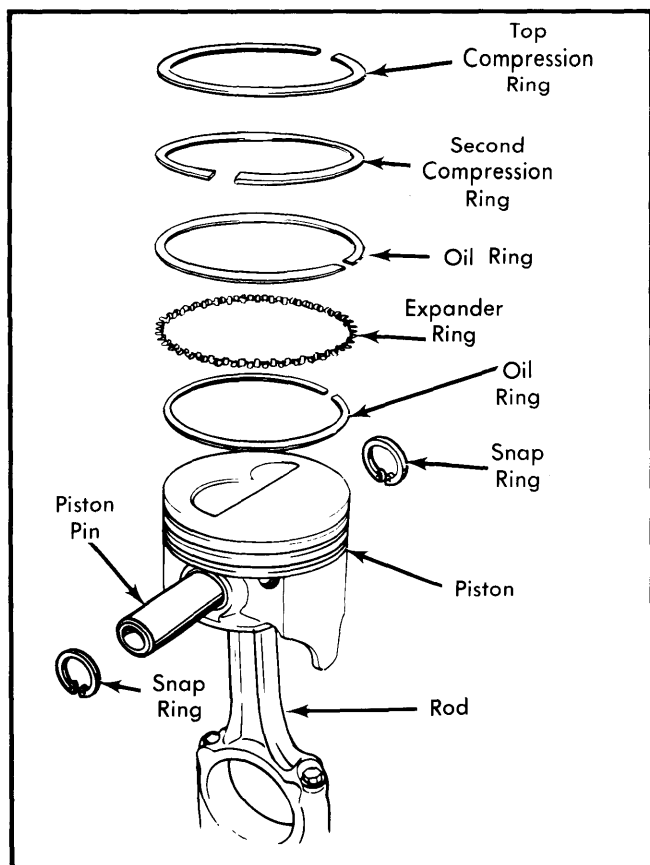

**Fig. 8 Exploded View of Piston and Rod Assembly Showing Piston Ring Positions**

**Installation** — 1) Lightly coat pistons, rings and cylinder walls with engine oil. Position rings as shown in Fig. 8. Make sure the marks on piston rings are toward top of piston. Using piston ring compressor, install piston with valve depression in top of piston turned toward inner side of engine. See Fig. 9.

2) On cylinders 1, 2, 3 & 4, the larger valve depression goes toward the front of engine. On cylinders 5, 6, 7 & 8, the larger depression goes toward rear of engine. See Fig. 9.

### FITTING PISTONS

**NOTE** — Each piston is fitted to its individual cylinder and should be marked for that cylinder.

1) Measure cylinder bores. Maximum taper and/or out-of-round is .001". Measure piston (with pin removed) for taper at pin centerline and at bottom of skirt. Measure for size  $\frac{3}{4}$ " below pin centerline. Maximum taper is .002". Piston-to-bore clearance should be .005-.006".

2) If clearance is not to specifications, bore may have to be honed or bored. Pistons are available in standard, high standard and .010" oversize. Mark piston and cylinder for oversize pistons.

**NOTE** — Vehicles may have oversize pistons fitted at factory, these pistons will be .010" oversize and marked.

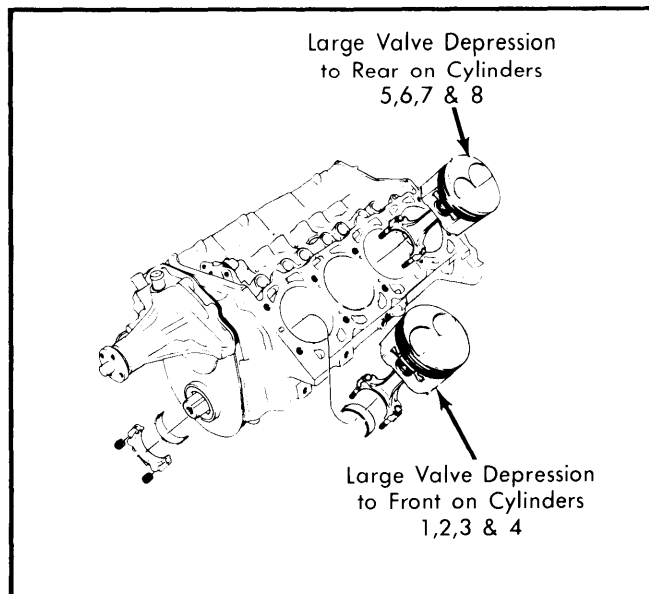

**Fig. 9 Installation of Piston Assemblies in Engine Showing Positioning of Piston Valve Depressions**

### PISTON PINS

Piston pin is free floating and can be inserted into piston or rod with hand pressure. Piston pin-to-rod clearance should be .0003-.0013". Piston pin-to-piston clearance should be .0003-.0005". Piston rod may be installed in the piston with either side facing up.

### CRANKSHAFT & ROD BEARINGS

#### CONNECTING ROD & MAIN BEARINGS

**NOTE** — .010" undersized crankshafts are used and are identified by a .010" stamped on number 6 counterweight.

**Connecting Rod Bearings** — 1) These bearings are designed to have slight projection above the rod and cap faces to ensure positive contact. They may be replaced without removing rod and piston assembly from engine.

2) Measure connecting rod journals with a micrometer to check out-of-round. Maximum out-of-round must not exceed .0015". Use Plastigage method to check bearing clearance. Maximum bearing clearance should be .0035". Coat bearings with engine oil before installation.

**NOTE** — All rods must be connected to journals before rotating crankshaft to prevent damage to engine.

3) Measure connecting rod side clearance by spreading rods with screwdriver and inserting feeler gauge. Clearance should be .006-.020".

**Main Bearings** — 1) Check bearing clearance. On engines not removed from vehicle, use floor jack or other support to hold crankshaft against upper bearing half.

2) Use Plastigage across full width of bearing. Install cap with bearing and tighten to 120 ft. lbs. Determine bearing

## 5.7L V8 DIESEL ENGINE (Cont.)

clearance by removing cap and check flattened Plastigage with graduations on container. If clearance is greater than .0035", replace BOTH bearing halves as a set.

**NOTE** — Main bearing clearance of .0035" is maximum allowable, but if bearing noise exists with this clearance, bearings must be replaced to reduce bearing clearance. NEVER use shims to reduce bearing clearance.

3) To replace main bearing halves, remove caps and lower shell. Insert a flattened cotter pin or rollout pin in oil passage hole of crankshaft. Rotate crankshaft in opposite direction of cranking rotation.

4) Check journals for roughness and wear. Out-of-round may be measured by inside micrometer or crankshaft caliper. Upper half must be removed when measuring journals. Maximum allowable out-of-round is .0015". Apply suitable lubricant to thrust flanges of No. 3 bearing. Reverse procedures to install new bearing halves.

**REAR MAIN BEARING OIL SEAL**

**NOTE** — Rear main bearing oil seal can be installed without removing crankshaft.

1) Drain oil, remove oil pan and rear main bearing cap. Use packing tool (BT-6433) against end of seal and drive oil seal into groove until it is packed tight. This may vary from 1/4" to 3/4", depending on amount of pack required. Repeat on other end of seal.

2) Measure amount seal was driven up on one side; add 1/16", then cut this length from old seal removed from bearing cap. Repeat on other side, again adding 1/16", then cut this length off old seal.

3) Place a drop of suitable sealer on each end of seal. Using 2 small screwdrivers, work these 2 pieces (one on each side) into block seal groove. Use packing tool to force short pieces into block.

4) Form a new rope seal in main bearing cap, packing by hand. Use rear main seal installing tool (J-28693) and hammer seal into groove.

**NOTE** — Seal is fully seated if undercut area of tool slides over seal. If tool butts against seal, drive seal further into groove.

5) Rotate tool before cutting off excessive packing. Reinstall main bearing cap and tighten.

**CAMSHAFT****FRONT COVER**

**Removal** — Drain cooling system and remove radiator and by-pass hoses. Remove belts, fan and fan pulley, crankshaft pulley, harmonic balancer and accessory brackets. Remove cover attaching bolts, cover, timing indicator and water pump. Remove both dowel pins.

**Installation** — 1) Grind a chamfer on one end of dowel pin. Cut excessive material from end of oil pan gasket on each side of block. Clean all mating surfaces with solvent. Trim 1/8" from each end of new pan seal. Install new front cover gasket on block and new seal on front cover. Apply suitable sealer to gasket around coolant holes and place on block.

2) Apply suitable sealer at junction of block, pan and front cover. See Fig. 10. Install front cover, pressing downward to compress seal. Rotate cover left and right to guide pan seal into cavity using a small screwdriver. See Fig. 11. Install 2 bolts and tighten finger tight. Install dowel pins (chamfered end first), into timing indicator and water pump and tighten bolts. Lubricate timing cover seal and install harmonic balancer. Reverse removal procedure to complete installation.

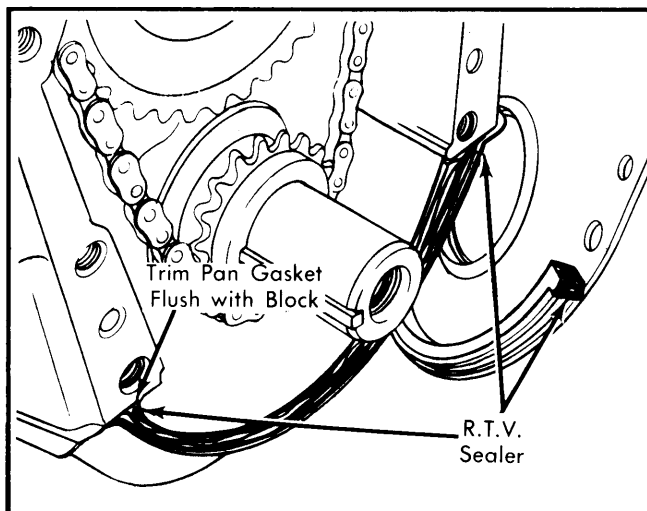

Fig. 10 Oil Pan and Front Cover Seal Installation

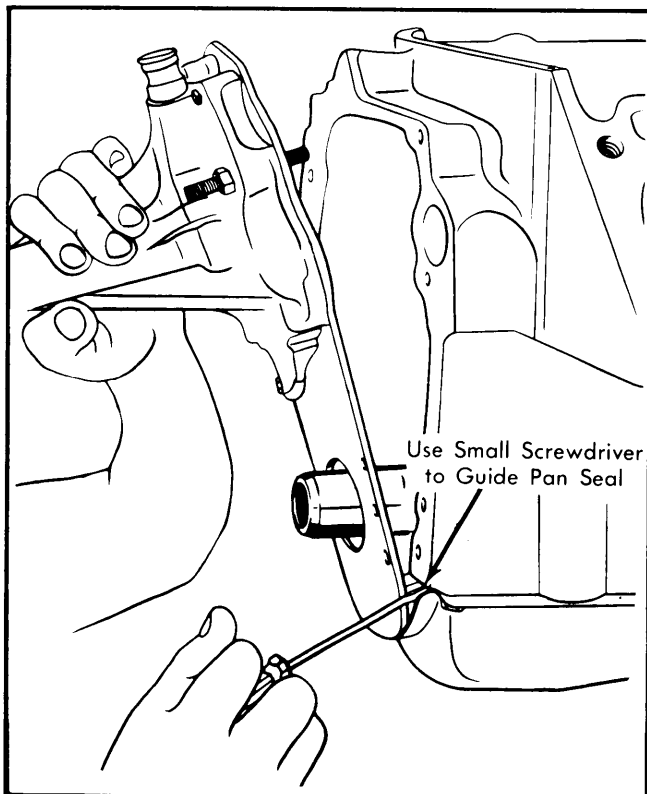

Fig. 11 Installation of Front Cover

**FRONT COVER OIL SEAL**

**Removal** — Remove belts, harmonic balancer, crankshaft pulley and hub. Remove front cover oil seal.

## 5.7L V8 DIESEL ENGINE (Cont.)

**Installation** — Apply sealer to outside of seal. Use seal installer (J-25264 and J-23952) to position and install seal. Reinstall components removed in removal procedure.

### TIMING CHAIN

**Removal** — Remove front cover, oil slinger, cam gear, crankshaft gear and key. Remove timing gear. Remove fuel pump eccentric only if replacement is necessary.

**Installation** — 1) Install key in crankshaft and fuel pump eccentric if removed. Install camshaft gear, crankshaft gear and timing chain together. When installing these components, make sure timing marks on both gears are aligned. See Fig. 12. Install oil slinger.

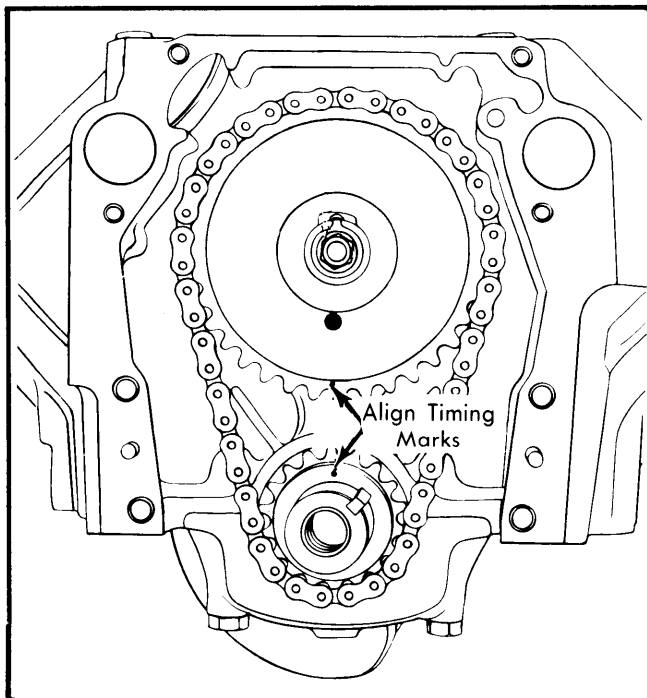

**Fig. 12** Aligning Crankshaft and Camshaft Gear Timing Marks

**NOTE** — When the 2 marks are aligned, No. 6 cylinder is at TDC. To obtain TDC for No. 1 cylinder, slowly rotate crankshaft 1 revolution. This will bring cam mark to top. No. 1 cylinder will then be in firing (TDC) position.

2) If timing chain or gears were replaced, engine will have to be retimed and marking on injection pump adaptor will have to be filed off and remarked. To retime engine proceed as follows:

3) File off the original mark on injection pump adapter. DO NOT file off mark on injector pump. Place engine at TDC on No. 1 cylinder and align mark on balancer with zero mark on indicator.

**NOTE** — The index is offset to the right when number 1 cylinder is at TDC.

4) Install special timing tool (J-26896) into pump adapter. Tighten tool, toward No. 1 cylinder, to 50 ft. lbs. Then, while

holding this torque, mark injection pump adapter. Remove tool. See Fig. 13.

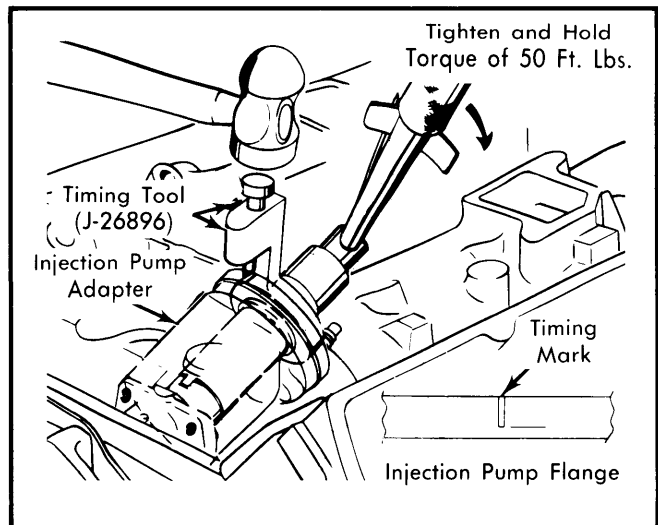

**Fig. 13** Marking Injection Pump Adapter When Retiming Engine

### CAMSHAFT

**Removal** — 1) Disconnect battery, drain cooling system, disconnect radiator hoses, cooler lines and remove radiator. Remove air crossover, all hoses, lines, wiring and linkage to intake manifold and remove manifold.

2) Remove fan, belts, balancer pulley, harmonic balancer, front cover, rocker arm covers, rocker arms, push rods and hydraulic lifters, keeping them in sequence for reassembly. If equipped with air conditioning, discharge system and remove condenser. Remove timing chain and gears.

3) Position camshaft dowel at 3 o'clock position. Hold camshaft to rear and remove pump drive gear by sliding off camshaft while rocking pump driven gear. Remove injection pump adapter, then remove snap ring and selective washer. Remove driven gear and spring. Remove camshaft carefully sliding out front of engine.

**NOTE** — Do not force shaft as damage can occur to bearings.

**Installation** — To install camshaft, reverse removal procedure. Apply suitable lubricant to camshaft and bearings prior to installation.

### CAMSHAFT BEARINGS

**Removal** — 1) Oil pan must be removed to replace camshaft bearing.

**NOTE** — Camshaft bearings are replaced as a complete set only. All bearings must be removed first before installing new bearings.

2) Remove camshaft. Use bearing remover set (J-6098-01) and handle (J-8092) to drive out camshaft bearings. Remove bearings in sequence, starting with No. 1.

## 5.7L V8 DIESEL ENGINE (Cont.)

3) To remove injection pump driven gear bushings, drive both bushings out at the same time from rear to front of block, using pump drive shaft tool (J-28439-2 & J-8092).

**Installation** — 1) To install, reverse procedure and place each bearing in front of bore with tapered edge toward block.

**NOTE** — Install bearings beginning with No. 5.

2) Align oil hole in bearings with center of oil slot in each bore. Mark bottom of bearing to act as a guide. Use a piece of  $\frac{3}{32}$ " brass rod with a 90° bend at one end to check oil hole opening. Wire must enter hole. See Fig. 14.

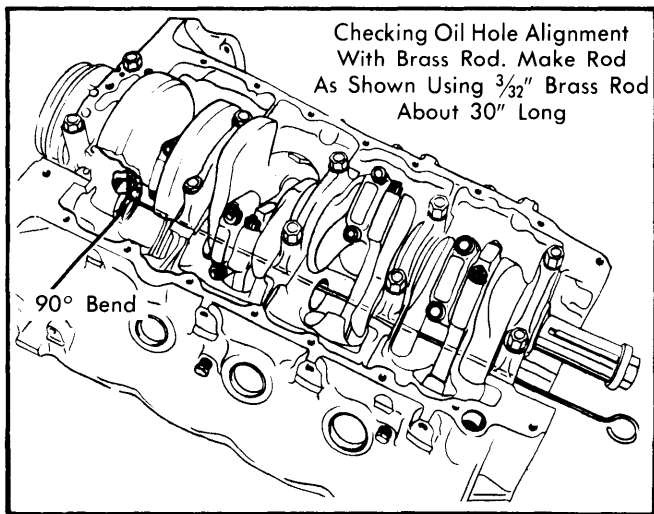

**Fig. 14** Checking Cam Bearing Oil Hole Alignment Using Brass Rod

### ENGINE OILING SYSTEM

Oil pump is gear type driven by camshaft gear through hexagonal drive shaft. Oil is delivered to right gallery where it is distributed to the five main bearings. The right bank valve lifters receive oil from this gallery through eight feed holes that intersect gallery. Camshaft bearings are lubricated from vertical passages intersecting main bearing oil passages and the left bank lifters receive oil through connecting passages from right gallery. The injection pump driven gear gets oil from passages in front camshaft bearing.

Rear driven gear bearing receives oil from passage in shaft of driven gear and vacuum pump is oiled by orifice in rear oil gallery plug. An orifice in front of right gallery lubricates the timing chain and fuel pump eccentric. Rocker arms and valve tips are lubricated through lifters and hollow push rods. Vacuum pump driven gear is oiled through left rear gallery and connecting rod bearings receive oil from drilled passages in crankshaft. Grooves around each main bearing furnish oil to drilled crankshaft passages.

### OIL PUMP

**Disassembly** — Remove oil pump drive shaft extension. Place shop towel or wooden block over pressure regulator bore, then remove cotter pin. Remove spring and pressure regulator valve. Remove oil pump cover, gasket, drive gear and idler gear from pump body. See Fig. 15.

**Reassembly** — 1) Install idler and drive gear in pump body. Check gear end clearance by placing straightedge over gears and measuring clearance between straightedge and gasket surface.

2) Clearance must be .0005-.0075". If end clearance is near maximum reading, check cover for scoring. Reinstall pressure regulator valve, spring and cotter pin. Replace parts as necessary.

**NOTE** — When installing extension, the end nearest washer must be inserted into drive shaft. Make sure washer is  $1\frac{1}{32}$ " from end of shaft.

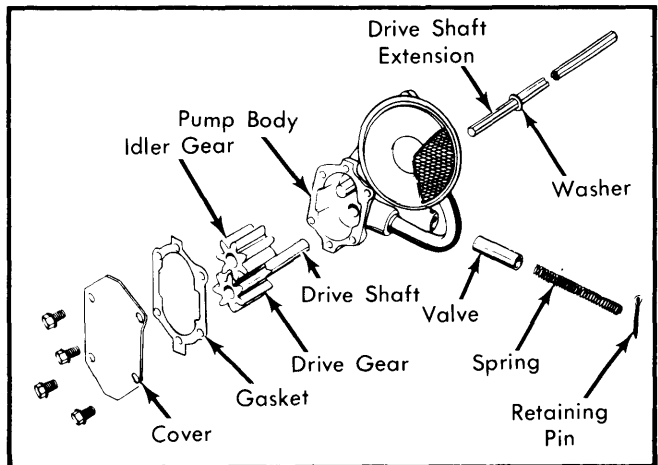

**Fig. 15** Exploded View off Oil Pump

### ENGINE SPECIFICATIONS

GENERAL SPECIFICATIONS							
Engine	Cycle	Displ. Cu. Ins.	Compr. Ratio	Bore	Stroke	Firing Order	Inj. Timing
5.7L	4	350"	22.5:1	4.057"	3.385"	1-8-4-3-6-5-7-2	.....

# General Motors V8 Engines

## 5.7L V8 DIESEL ENGINE (Cont.)

### ENGINE SPECIFICATIONS (Cont.)

VALVES							
Engine & Valve	Head Diam.	Face Angle	Seat Angle	Seat Width	Stem Diameter	Stem Clearance	Valve Lift
5.7L							
Int. ①	1.875"	44°	45°	.075-.098"	.3425-.3432"	.0010-.0027"	.....
Exh.	1.625"	30°	31°	.037-.075"	.3420-.3427"	.0015-.0032"	.....

① — Induction hardened valve seat used.

PISTONS, PINS, RINGS						
Engine	PISTONS	PINS		RINGS		
	Clearance	Piston Fit	Rod Fit	Rings	End Gap	Side Clearance
5.7L	.005-.006"	.0003-.0005"	.0003-.0013"	1	.015-.025"	.005-.007"
				2	.015-.025"	.0018-.0038"
				3	.015-.055"	.001-.005"

CRANKSHAFT MAIN & CONNECTING ROD BEARINGS							
Engine	MAIN BEARINGS				CONNECTING ROD BEARINGS		
	Journal Diam.	Clearance ①	Thrust Bearing	Crankshaft End Play	Journal Diam.	Clearance	Side Play
5.7L	2.9993-3.0003"	.0005-.0021"	No. 3	.0035-.0135"	2.1238-2.1248"	.0005-.0026"	.006-.020"

① — Journals 1,2,3 & 4. No. 5 journal .0015-.0031"

VALVE SPRINGS			
Engine	Free Length	PRESSURE (LBS.)	
		Valve Closed	Valve Open
5.7L	2.09"	85-95@1.67"	203-207@1.30"

CAMSHAFT			
Engine	Journal Diam.	Clearance ①	Lobe Lift
5.7L			
No.1	2.0357-2.0365"	.0020-.0058"	.....
No.2	2.0157-2.0165"	.0020-.0058"	.....
No.3	1.9957-1.9965"	.0020-.0058"	.....
No.4	1.9757-1.9765"	.0020-.0058"	.....
No.5	1.9557-1.9565"	.0020-.0058"	.....

① — End play is .011-.077".

TIGHTENING SPECIFICATIONS	
Application	Ft. lbs.
Camshaft Sprocket Bolt .....	65
Connecting Rod Nut .....	42
Cylinder Head ① .....	130
Exhaust Manifold-to-Head Bolts ② .....	25
Flywheel-to-Crankshaft .....	60
Flywheel-to-Converter .....	40
Injection Pump Adapter .....	25
Injection Pump Nuts .....	19
Intake Manifold ①③ .....	40
Main Bearing Cap Bolt ① .....	120
Oil Pump Bolts .....	35
Oil Pump Cover Bolts .....	8
Rocker Arm Pivot Bolts .....	28
Vibration Damper .....	200-300

① — Dip entire bolt in engine oil before installing.  
 ② — Left side exhaust manifold forward bolt is tightened to 30 ft. lbs.  
 ③ — Intake is tightened in 2 steps; Step 1 — 15 ft. lbs. Step 2 — 40 ft. lbs.