

Positive Traction Differentials

EATON (ONE PC. CASE) LOCKING DIFFERENTIAL

Chevrolet
All 10 Series & G20
GMC
All 1500 Series & G2500

DESCRIPTION

The Eaton one piece case locking differential is a 2 pinion type with a clutch disc pack behind each side gear. Unit also utilizes a speed sensitive device which automatically locks both rear wheels if either wheel should spin excessively during slow vehicle operation.

AXLE RATIO & IDENTIFICATION

See General Motors 8 1/2" & 8 7/8" Ring Gear article in this Section.

LUBRICATION

Check lubricant level every 7500 miles or 6 months. Drain and refill every 15,000 miles. Use standard differential lubricant, DO NOT use Positraction lubricant.

TESTING ON VEHICLE

1) Raise vehicle so that both rear wheels can be rotated freely by hand. With one wheel held stationary, rotate other wheel approximately 1/2 turn every second. Wheel should rotate freely. If both wheels turn, or try to turn, differential is defective.

2) Raise vehicle as high as possible. Leave one technician in vehicle. Start engine and allow to idle at 600-800 RPM. If equipped with automatic transmission, place transmission in drive and apply brakes. If equipped with manual transmission, depress clutch and place transmission in first gear.

3) Pull on one parking brake cable from under vehicle to lock one rear wheel. With engine idling, slowly release brakes on automatic transmission models and slowly release clutch on manual transmission models. Locked rear wheel should remain stationary and free wheel should rotate slowly.

4) As free wheel speed increases, the differential should lock, causing both wheels to rotate or stop.

NOTE - If equipped with manual transmission, engine may stall.

5) It may be necessary to accelerate to 10 MPH to lock differential. If speed increases beyond 20 MPH without locking differential, unit is defective. Lock opposite wheel and repeat test.

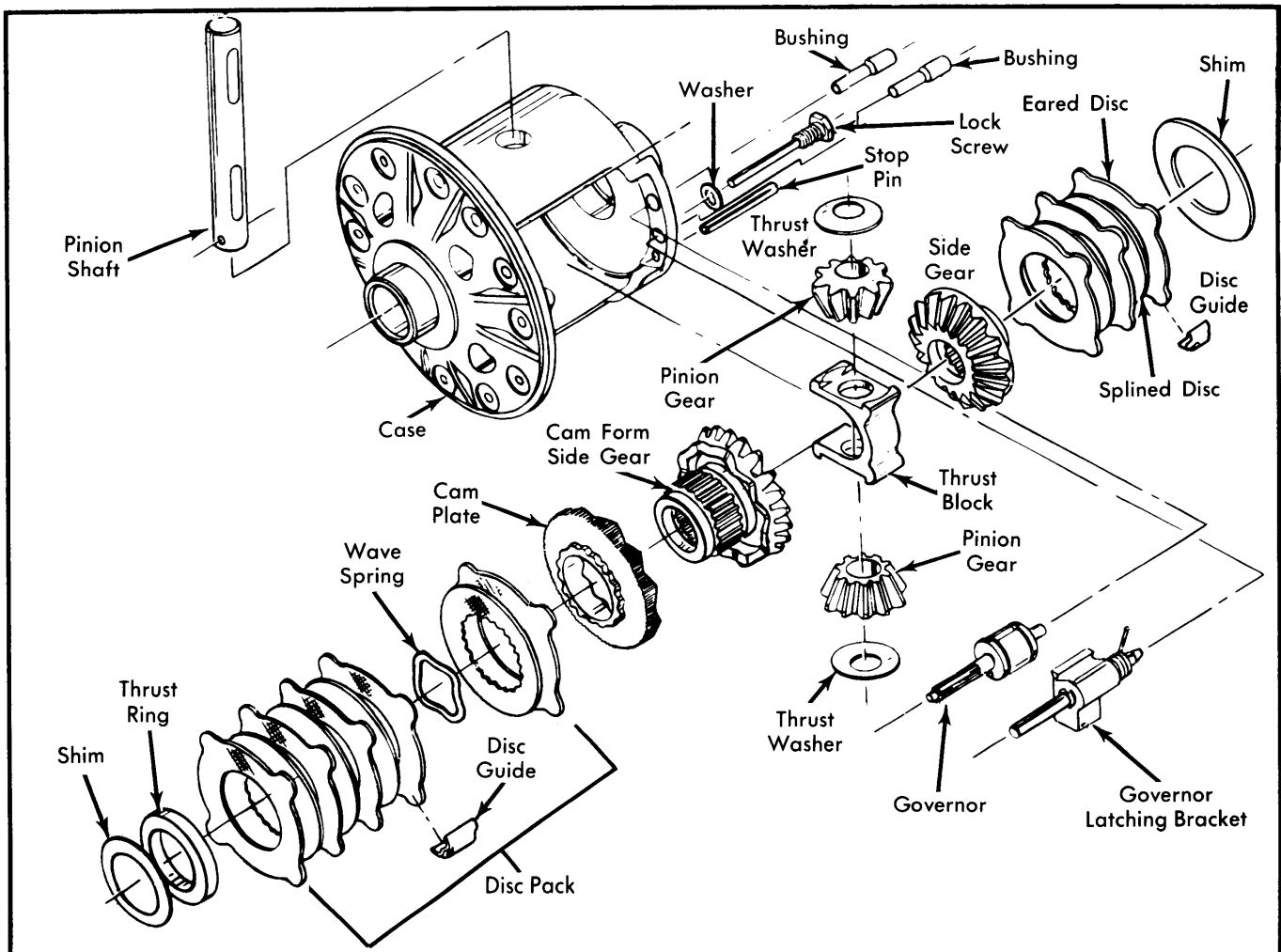

Fig. 1 Exploded View of Eaton One Piece Case Locking Differential

EATON (ONE PC. CASE) LOCKING DIFFERENTIAL (Cont.)

TROUBLE SHOOTING

Does Not Lock – Little or no spring preload on latching bracket. Governor assembly flyweights stuck closed. Governor or cam gear drive teeth broken. Cam gear clutch plates broken.

Locks In Turns – Tight governor assembly in case. Governor flyweights broke, weak, or stuck. Governor or cam gear drive teeth broken.

Excessively Noisy – Broken clutch plates. Broken reaction block. Broken differential gears.

REMOVAL & INSTALLATION

Same procedure is used to remove and install locking differential as conventional differential. See *General Motors 8 1/2" & 8 7/8" Ring Gear in this Section.*

OVERHAUL

DISASSEMBLY

Differential – 1) With differential removed from housing, remove ring gear and side bearings. Note or mark position of latching bracket and governor assembly for reassembly. Using puller tool (J-26252 or equivalent), remove bushings retaining latching bracket and governor. Remove latching bracket spring while pulling out governor assembly bushing.

2) Remove stop pin by driving through case with drift punch. Remove pinion shaft lock screw and remove pinion shaft. Roll pinion gears out of case. Remove reaction block and pinion thrust washers. Remove cam gears, disc packs and disc pack guide clips on both sides.

NOTE – *If cam gear or clutch discs must be replaced, the cam gear assembly must be disassembled as follows:*

Cam Gear Assembly – 1) Measure and record overall length of gear assembly. Measure from face of gear to backside of thrust ring and include shim. This dimension will be required for reassembly if thrust ring is replaced.

NOTE – *Thrust ring should be replaced only if it is absolutely necessary.*

2) If thrust ring is replaced, check thrust ring bore in case for wear. If bore is scored excessively, replace complete differential.

3) Position gear with hub end up. Compress disc pack and place a suitable bearing removal mandrel (J-22912) between thrust ring and top disc. Beveled side of tool should be toward thrust ring. Position cam gear and tool in a press with tool supported on both sides. Place a 1 1/2- 1 3/4" plug on gear hub. Press against plug with press to remove thrust ring. Make sure all components are kept in correct order.

INSPECTION

Clean all parts in a suitable solvent. Inspect all bearings and gear teeth for chipping or wear. Replace as necessary. Inspect clutch plates and discs for signs of wear or overheating. If

reaction block or flange shims must be replaced, measure thickness of original components and replace with components of identical size.

REASSEMBLY

NOTE – *If cam gear assembly was disassembled, reassemble as follows:*

Cam Gear Assembly – 1) Place cam gear on bench with hub end up. Place cam plate on gear so that cam form on plate is against cam form on gear. Position on cam plate two eared discs, one splined disc and one wave spring, alternately in that order. Position on gear hub 2 splined discs and 3 eared discs alternately, starting and ending with an eared disc.

2) Place cam gear in a press with hub end up. Install thrust ring on gear hub with press. Make sure thrust ring is square with hub. Press thrust ring on until it is flush with shoulder. When installing ring, press down on discs to make sure splined disc does not wedge between thrust ring and gear shoulder. When unit is assembled, check for correct disc sequence. Make sure that the first splined disc (large spline) is correctly located on cam plate.

Differential – 1) Install disc pack guide clips on disc ears of cam gear disc pack. Use grease to retain clips on ears. Install cam gear assembly, with original shim in flange end of case. If a new thrust ring has been installed on cam gear, it may be necessary to reshim. Measure overall length of cam gear assembly, including shim. Compare this measurement with one previously recorded. If measurement variation is more than .003" either way, install a new shim that will obtain a reading within .003" of original measurement.

2) Place an axle shaft in vise in a vertical position. Place cam gear assembly in differential case. Position differential case over splined end of axle and align axle splines with gear splines. Lubricate both pinion thrust washers and place in case. Install opposite end side gear with original shim.

NOTE – *Original shim must be used to maintain correct clearance specification.*

3) Install one pinion gear through small opening in case, while inserting other pinion gear and reaction block through larger opening in case. Rotate both pinion gears and reaction block 90° so that open side of reaction block is toward small opening in case. Make sure both pinion gears and thrust washers remain in correct position. Install pinion shaft and lock screw.

4) Place governor assembly and latching bracket into case. Place straight end of latching bracket spring over and to the outside of the engagement shaft. This will preload the latching bracket against the governor assembly.

NOTE – *The latching bracket bushing has a tapered hole and the governor assembly bushing has a straight hole.*

5) Press bushing and 1/4" stop pin into case. Install governor bushing in case making sure shaft end play is between .004-.020". Press latching bracket bushing into case so end play is removed. Press stop pin flush with case, install ring gear and side bearings on differential.