

DANA/SPICER FULL-FLOATING AXLES

Chrysler Corp.
 Ford Motor Co.
 General Motors
 International Harvester
 Jeep

NOTE — DRIVE AXLE USAGE — With the exception of some General Motors models, all front drive axles are a Dana/Spicer Full-Floating axle. Chevrolet and GMC models can be equipped with either a General Motors 8 1/2" Ring Gear or a Dana/Spicer Full-Floating front drive axle. All models may use other rear drive axles. See appropriate articles in this section.

DESCRIPTION

Dana/Spicer axles come in different models for application in vehicles with a wide range of GVW ratings. Service and overhaul procedures for all full floating axle models are the same except for drive pinion depth and some torque specifications. The axle assembly has an integral differential carrier and an over-hung mounted drive pinion. The drive pinion depth, pinion bearing preload, and differential side bearing preload are all set by shims. Other than the unique components required for front wheel drive units, front and rear axles are identical.

AXLE RATIO & IDENTIFICATION

All Dana/Spicer axles have an integral carrier with a removable rear cover plate. The cover plate has a unique shape that allows positive identification of Dana/Spicer axles on any model vehicle. The axle model is often cast on the differential housing, or it can be determined by measuring the diameter of the ring gear. See following chart. To determine the drive axle ratio, refer to Drive Axle Ratio Identification in this Section.

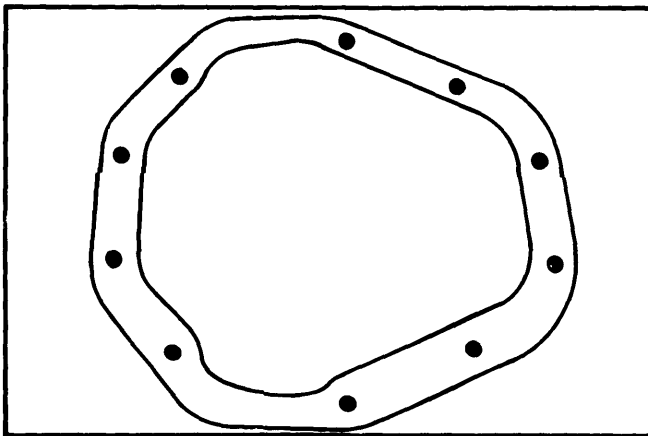

Fig. 1 Dana/Spicer Housing Cover Gasket for Identification Purposes

Model Identification By Ring Gear Size

Ring Gear Diameter	Model Number
7.125"	30-XX
8.500"	44-XX
9.750"	60-XX
10.500"	70-XX

REMOVAL & INSTALLATION

FRONT AXLE SHAFTS & BEARINGS

Removal (Chrysler Corp. Model 44FBJ Axle) — 1) Remove wheel cover and cotter key. Loosen outer axle shaft nut. Raise vehicle and support with safety stands. Remove brake caliper.

NOTE — Do Not let caliper hang from brake line.

2) Remove outer axle shaft nut and washer. Place a suitable puller (C-4358) on wheel studs and install lug nuts. Tighten puller screw to remove rotor and hub assembly. Remove puller from hub.

3) Using a suitable bearing press (C-293-PA), pull outer bearing cone from hub. Discard outer seal. Remove six bolts from retainer and remove retainer from steering knuckle. If necessary, remove brake caliper adapter from steering knuckle.

4) Position a pry bar behind inner axle shaft yoke. Push bearings out of knuckle with pry bar. Remove "O" ring from steering knuckle if equipped. Carefully slide out axle shaft assembly.

Inspection — Check knuckle bore and inner seal surface for wear. Replace knuckle if necessary. Temporarily install bearing cups and spacers into knuckle bore. Place bearing retainer on steering knuckle. Tighten bolts to 30 ft. lbs. Insert a .004" feeler gauge between retainer ears and knuckle. If there is no clearance, replace knuckle.

Installation — 1) Apply RTV sealer to the seal surface of axle shaft. Measure in 3/8" from yoke shoulder of axle shaft. Using a center punch, stake surface at 1/4" intervals. This will ensure a tight fit of inner seal slinger.

2) Using a suitable driver, install seal slinger on outer axle shaft. Install seal with lip toward axle shaft spline. Carefully install axle shaft in the housing, taking care not to damage differential side gear seal.

3) Insert a pry bar through axle shaft "U" joint and wedge axle in all the way. Using a suitable driver tool and adapter (C-4398-1 and C-4398-2), install seal cup in knuckle. Make sure it bottoms fully. Do not remove tool now.

4) Using a suitable driver (C-4250) install a new outer seal in retainer plate. Place retainer plate in position over hub of rotor. Pack wheel bearings with suitable lubricant (MOPAR Lubricant Part No. 2525035).

5) Using a suitable pressing tool and adapters (C-4264-A), carefully press outer bearing onto hub. Remove pressing tool. Place grease coated outer bearing cup over outer bearing cone. Install spacer, inner bearing cup and cone.

6) Using pressing tool again (C-4264-A), carefully press bearing cones and cups into position. Remove pressing tool. Place a 1/4" bead of RTV sealer on chamfer of retainer face. This replaces "O" ring discarded during removal.

7) Carefully remove seal installing tool from knuckle bore. Make sure outer axle shaft remains centered. **CAUTION** — If axle shaft moves, make sure that lip of seal is still riding inside cup.

DANA/SPICER FULL-FLOATING AXLES (Cont.)

8) Place bearing retainer in hub and rotor so that lube fitting is facing directly forward. **NOTE** – Lube fitting *MUST* be facing forward. Install hub and rotor assembly on knuckle. Tighten bolts to 30 ft. lbs.

9) If removed, install brake adapter. Tighten bolts to 85 ft. lbs. Remove pry bar from "U" joint and install axle shaft washer and nut. Tighten nut to 100 ft. lbs. Install cotter key. Tighten nut to align cotter key holes if necessary.

10) Insert a grease gun through access hole in hub and rotor assembly. Fill with suitable lubricant (MOPAR Part No. 2525035) until grease flows through new inner seal at "U" joint area.

11) Remove lube gun. Rotate hub and rotor several times until grease flows from at least 50% of seal diameter. Install brake caliper assembly. Install wheel and tire. Lower vehicle.

Removal (Chrysler Corp. Model 60 Axle) – 1) Block brake pedal up. Raise vehicle and place on safety stands. Remove wheel and tire. Remove brake caliper. Do not let caliper hang from brake line.

2) Remove cap from center of hub. Remove snap ring. Remove flange nuts and lock washers. Remove drive flange and discard gasket. Straighten tang on lock ring. Remove outer lock nut, lock ring, inner lock nut and outer bearing. Carefully slide hub and rotor off spline.

3) Remove oil seal and inner bearing from hub. Remove bearing cups with a brass drift punch. Remove inner brake pad from adapter. Remove rotor splash shield, brake adapter and spindle to knuckle nuts. Remove spindle from steering knuckle. Slide out inner and outer axle shaft with bronze spacer, seal and oil slinger.

Installation – 1) Slide axle shaft into position. Place bronze spacer on axle shaft with chamfer side facing toward "U" joint. Install spindle, brake adapter and brake splash shield. Tighten nut to 50-70 ft. lbs.

2) Drive in bearing cups using a suitable installer. Lubricate bearings with suitable lubricant (MOPAR Lubricant Part No. 2525035). Install inner bearing in grease coated hub. Install new seal. Care must be taken not to damage seals.

3) Install hub and rotor assembly on spindle. Install outer wheel bearing and inner lock nut, tightening to 50 ft. lbs., back off then retighten to 35 ft. lbs. Install outer lock nut and tighten to 65 ft. lbs. Install new gasket on hub, install drive flange lock washers and nuts. Install snap ring and cap in hub, install brake caliper, wheel and tire then lower vehicle.

Removal (Ford Motor Co.) – 1) Raise vehicle and support on safety stands. Remove wheel and tire. Remove cap from center of hub and remove snap ring. Pry out driving hub and spring. Remove wheel bearing lock nut, lock ring and adjusting nut.

2) Remove hub and rotor assembly. The outer wheel bearing and retainer will slide out with hub. Drive inner bearing cone and grease seal out of hub. Remove brake support bracket

nuts. Remove dust shield and spindle. Pull axle shaft assembly out through hole in steering knuckle. Care must be taken not to damage seal.

Installation – 1) Install new seal and deflector on axle shaft. Install spacer on axle. Apply lubricant to exposed area of spacer. Slide axle into position taking care not damage seal in axle housing. Install brake dust shield, spindle and brake support bracket. Tighten nuts to 30-40 ft. lbs.

2) Lubricate bearings with suitable lubricant (Ford Spec. ESA-MIC92-A). Clean old grease from hub. Place inner bearing cone and roller in inner cup and install grease retainer. Carefully install hub and rotor assembly on spindle.

3) Install outer bearing. Install adjusting nut and tighten to 50 ft. lbs. and back off $\frac{3}{8}$ turn. Install outer lock nut and tighten to 90 ft. lbs. Install drive hub, spring and snap ring. Install locking hub, caliper, wheel and tire then lower vehicle.

Removal (General Motors) – 1) Raise vehicle and support on safety stands. Remove tire and wheel. Remove brake caliper. If equipped with locking hubs, turn actuator lever to "LOCK" position. Rotate hub and remove 6 retaining plate bolts and remove plate, actuating knob and "O" ring. Remove snap ring, outer clutch retaining ring and cam body.

2) On all models, remove lock nut, washer and adjusting nut from spindle. Slide off hub and rotor assembly. Outer wheel bearing and retainer will come off with hub. Remove inner bearing, cone and seal from hub using a brass drift punch. Remove inner and outer bearing cups (if necessary) using a brass drift punch. Remove spindle. Carefully pull axle shaft assembly out through hole in steering knuckle.

Installation – 1) Install axle shaft assembly in housing. Care must be taken not to damage seal. Install thrust washer with chamfered end toward slinger on axle. Install spindle. Tighten bolts to 25 ft. lbs. (K10, K1500, K20 and K2500) and to 60 ft. lbs. (K30 and K3500).

2) Install inner and outer bearing cones in hub using suitable drivers. Lubricate cones and bearings with suitable wheel bearing lubricant. Install inner bearing in cone and install new seal. Install outer bearing and retainer in hub.

3) Position hub and rotor assembly on spindle. Install inner adjusting nut, tightening to 50 ft. lbs., back off then retighten to 35 ft. lbs. Install outer lock nut and tighten to 65 ft. lbs. Complete reassembly by reversing removal procedure.

Removal (IHC) – 1) Raise vehicle and support with safety stands. Remove wheel and tire. Remove brake caliper. If equipped with locking hubs, remove screws and remove hub. Remove snap ring and pry out driving hub and spring. Remove wheel bearing lock nut, lock ring and adjusting nut.

2) On all vehicles, remove lock nut after bending lock tab. Remove inner adjusting nut and keyed thrust washer. Remove rotor and hub assembly. Remove spindle retaining nuts and remove spindle and bearing. Pull axle shaft out through steering knuckle.

DANA/SPICER FULL-FLOATING AXLES (Cont.)

Installation — Install axle shaft assembly in vehicle. Care must be taken not to damage seal in housing. Install spindle on steering knuckle. Thoroughly grease bearings and cups. Place rotor and hub assembly in position on spindle. Install inner adjusting nut and tighten to 30 ft. lbs. then back off $\frac{1}{4}$ turn. Install outer lock nut and tighten to 125 ft. lbs. Install drive hub, spring and snap ring. Install locking hub, caliper, wheel and tire then lower vehicle.

Removal (Jeep CJ Models) — 1) Raise vehicle and position on safety stands. Remove wheel and tire. Remove disc brake caliper. Remove drive flange cap from center of hub.

2) Remove drive flange snap ring. Remove bolts securing drive flange to rotor hub. Remove drive flange using a suitable puller (J-25133 or equivalent).

3) Straighten washer lip and remove outer lock nut. Remove washer, inner lock nut and bearing washer. Remove outer bearing and disc brake rotor.

4) Remove disc brake caliper adapter and splash shield. Remove spindle nuts and remove spindle. Carefully pull out axle shaft and "U" joint assembly. Drive inner bearing and seal from hub.

Installation — 1) Make sure all components are clean. Make sure drive flange bolt and bolt hole threads are clean. Install inner bearing and seal in hub.

2) Install axle shaft assembly taking care not to damage seal in axle housing. Install spindle and spindle bearing. Install disc brake caliper adapter and splash shield.

3) Lubricate and install outer bearing in hub assembly. Install hub assembly on spindle. Install washer and adjusting nut and tighten to 50 ft. lbs. then back off $\frac{1}{3}$ turn. Install lock washer and lock nut, tightening lock nut to 50 ft. lbs. and bend lock washer lip over lock nut.

4) Install drive flange and gasket. Coat drive flange bolts with a suitable Adhesive-Sealant (Loctite 242 or equivalent). Install drive flange bolts.

5) Install drive flange snap ring in groove at outer end of axle shaft. Install disc brake caliper. Install hub grease cover. Install wheel and tire and lower vehicle.

Removal (Jeep, Exc. CJ Models) — 1) Raise vehicle and position on safety stands. Remove wheel and tire. Remove disc brake caliper. Remove rotor hub dust cap.

2) Remove axle shaft snap ring, drive gear, pressure spring, and spring retainer. Remove outer lock nut, washer and inner lock nut. Remove rotor (spring retainer and outer bearing are removed with rotor).

3) Remove spindle and support shield. Carefully remove axle shaft and "U" joint assembly. Remove inner bearing and seal from rotor hub.

Installation — 1) Install inner bearing and seal in rotor hub. Carefully insert axle shaft in position in axle housing. Install spindle and support shield.

2) Place hub assembly on spindle, install outer bearing and inner adjusting nut, tightening adjusting nut to 50 ft. lbs. and

back off nut $\frac{1}{3}$ turn. Install lock washer by aligning nearest hole in lock washer with adjusting nut pin. Install outer lock nut and tighten to 50 ft. lbs.

3) Install spring retainer, pressure spring and drive gear. Install retainer with cupped side of retainer facing toward center of vehicle.

4) Push drive gear in. This will provide clearance for axle shaft snap ring. Install snap ring. Install rotor hub cap. Install disc brake caliper. Install wheel and tire and lower vehicle.

STEERING KNUCKLE (FRONT DRIVE AXLE)

NOTE — Steering knuckle does not have to be removed to service front axle assembly.

Removal — 1) Remove hub and disc assembly, spindle and axle shaft as previously described. Disconnect tie rod(s) from steering arm and/or knuckle. If steering arm is removed, discard self-locking nuts. Remove cotter pin from upper ball socket nut.

2) Loosen both retaining nuts from upper and lower ball sockets. Insert wedge shaped tool between lower ball stud and yoke and tap firmly with hammer to separate knuckle assembly. Repeat procedure for upper ball stud and remove retaining nuts and steering knuckle assembly.

NOTE — DO NOT remove upper ball stud adjusting sleeve unless new ball studs are being installed. Yoke can be easily damaged by hardened threads in adjusting sleeve if care is not used during knuckle removal.

Installation — Reverse removal procedure.

REAR AXLE SHAFTS & BEARINGS

Removal — 1) Remove flange nuts from hub studs. Using heavy hammer, rap sharply on center of axle flange to loosen tapered dowels (if equipped). Remove dowels. Rap center of flange again to cause flange and axle assembly to spring away from hub. Remove axle without using prying devices which might damage axle flange and hub mating surfaces. To service bearings, remove locking devices and bearing adjusting nut. Pull wheel straight off axle housing using care to avoid dropping bearing cones. Remove and discard seal(s). Remove bearing cones from hub or axle housing.

NOTE — Close inspection of hub and axle type is necessary to determine which procedure applies.

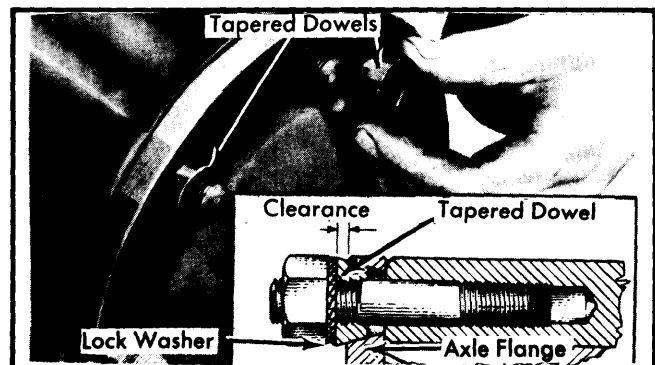

Fig. 2 Detail View of Tapered Dowels

DANA/SPICER FULL-FLOATING AXLES (Cont.)

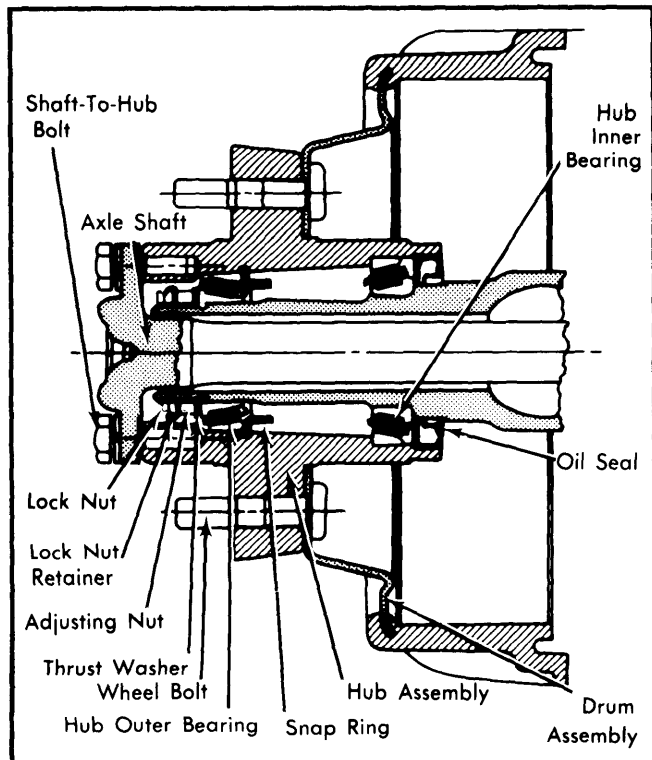

Fig. 3 Sectional View of Axle Shaft and Bearings With Snap Ring Bearing Retainer

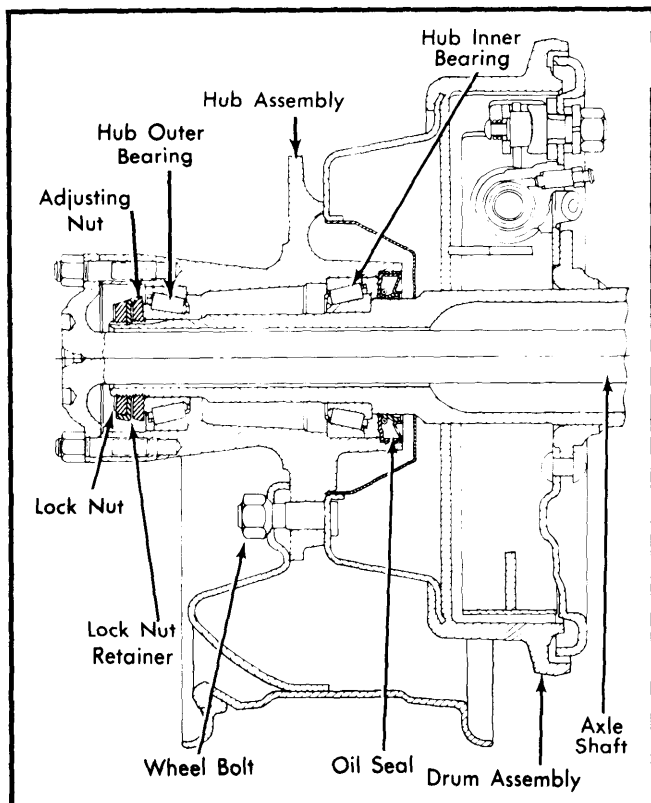

Fig. 4 Sectional View of Axle Shaft and Bearings With Machined Shoulder Bearing Retainer

2) Two methods are used to position outer bearing cup in hub: Seating cup against a machined shoulder, and seating cup against a removable snap ring set into a machined groove. To remove machined shoulder type, drive each bearing cup out of hub using a long drift or suitable tool. To remove snap ring type, remove inner cup with long drift. Remove snap ring with pliers. Using a suitable tool, drive outer bearing and cup out of hub.

Installation — To install machined shoulder type, drive or press inner and outer bearing cups into place using a suitable tool. Make sure that cups are firmly seated against shoulders in hub. To install snap ring type, insert outer bearing cone into hub. Insert bearing cup into hub and drive beyond snap ring groove. Install snap ring. Drive cone and cup assembly back against snap ring making sure that it is fully seated. Install inner bearing cup and cone. Install seals. Adjust wheel bearing. See *Rear Wheel Bearing Adjustment* in *WHEEL ALIGNMENT* Section.

PINION FLANGE & SEAL

NOTE — Pinion seal can be serviced with axle assembly installed in vehicle.

Removal — Disconnect drive shaft and scribe a line down pinion shaft, flange, and nut. Remove nut and, using a suitable tool, remove flange. **CAUTION** — Do not hammer flange off. Damage to pinion gear, ring gear, and bearing could result. Pry seal from bore using care not to damage machined surfaces.

Installation — Lubricate cavity between seal lips with a high melting point lubricant. Install seal into bore making sure that it bottoms against shoulder. Place flange on shaft and draw it down with pinion nut. Tighten pinion nut to specifications. **CAUTION** — Failure to tighten pinion nut to full specifications will result in flange or pinion shaft failure. Install drive shaft.

AXLE ASSEMBLY

Removal — Raise vehicle on hoist and support axle assembly to take weight off springs. Disconnect drive shaft at pinion flange and tie out of way. Remove hub and drum assembly. Disconnect vent tube (if equipped), and disconnect parking brake cable(s) and service brake hydraulic lines. Disconnect shock absorbers at axle brackets. Disconnect springs and remove axle.

Installation — Reverse removal procedure. Do not fully tighten shock absorbers nut until assembly is completed. Bleed hydraulic lines and adjust parking brake before moving vehicle.

OVERHAUL

DISASSEMBLY

NOTE — Remove axle housing assembly before beginning overhaul.

1) Remove axles and housing cover. Be sure that side bearing caps are marked so that they can later be installed in their

DANA/SPICER FULL-FLOATING AXLES (Cont.)

original positions. Remove bolts and side bearing caps. Use a housing spreader to spread differential housing .015-.020". Use a dial indicator to measure spread. **CAUTION** — Do not spread housing more than .020". Permanent damage to housing could result. Carefully pry differential case out of housing. Be careful not to damage machined surface of housing. Remove spreader immediately to prevent possibility of carrier taking a set.

2) If differential case is one piece, proceed as follows: Remove bolts holding ring gear to differential case, then tap ring gear off with soft-faced hammer. With a small punch, drive out lock pin. Remove differential shaft and thrust block. Remove differential pinion gears and thrust washers.

3) If differential case is two piece, proceed as follows: Remove bolts holding ring gear to differential case, then tap ring gear off with soft-faced hammer. Mark differential case halves to aid reassembly. Remove bolts and separate case halves. Remove pinion gear spider, pinion gears, side gears, and all thrust washers.

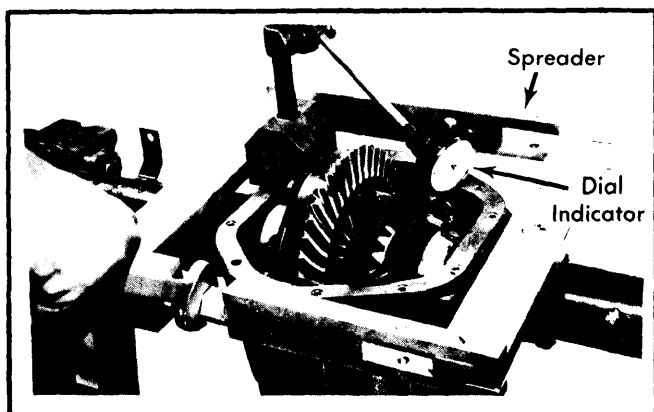

Fig. 5 Correct Procedure for Spreading Housing

4) Remove pinion nut. With suitable puller, remove pinion flange. Using soft-faced hammer, drive pinion shaft out of housing. **NOTE** — Pinion bearing adjusting shims may remain on pinion shaft, stick to bearing, or fall loose. Collect them and save them for reassembly. From pinion shaft bore, remove oil seal and bearing cone. A baffle or an oil slinger may also be present; record the order in which they were removed so that they may be installed correctly. Discard seal. Remove inner bearing cone and press pinion bearing off pinion shaft.

5) Using a suitable puller, remove side bearings from differential case. Often during removal of side bearings, shims between bearings and differential case are mutilated. If so, shims must be individually measured and their thicknesses recorded, so that new shim packs can be secured.

REASSEMBLY & ADJUSTMENT

Case Assembly — 1) If differential case is one piece, proceed as follows: Place differential case in holding fixture or vise. Lubricate side and pinion gears and all thrust washers and install in case. Rotate side gears until holes in pinion gears and washers line up with holes in case. Install spacer block (if equipped) and differential pinion shaft. If old thrust washers are used, check for preload of side gears by measuring clearance between side gears and case. Clearance should be

.000-.006"; if not, shims can be installed (in equal amounts on each side), or new thrust washers installed. Install lock pin andpeen over hole to retain pin. Install ring gear and tighten bolts to specifications.

2) If differential case is two piece, proceed as follows: Lubricate all parts with differential lubricant. Install differential side gears and thrust washers, pinion gear spider, pinion gears, and thrust washers in differential case. Check for preload of side gears by measuring clearance between side gears and case. Clearance should be .000-.006"; if not, shims can be installed (in equal amounts on each side), or new thrust washers installed. Rejoin case halves using aligning marks made during reassembly. Tighten bolts to specifications. Install ring gear and tighten bolts to specifications.

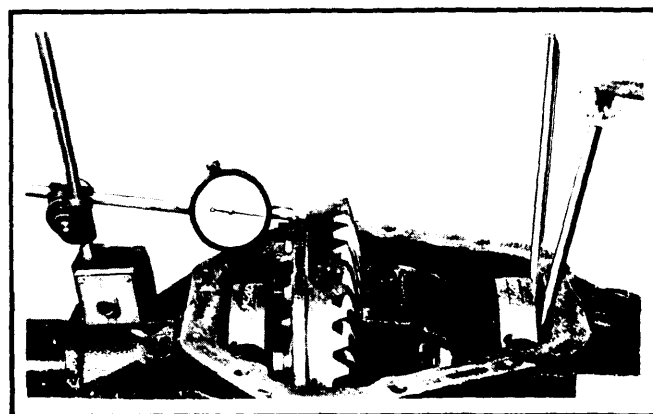

Fig. 6 Using Dial Indicator to Measure Differential End Play

3) Install differential side bearings. Assemble case in housing WITHOUT shims. Install bearing caps and tighten bolts just enough to seat bearing cups. Mount dial indicator to read at back of differential flange. Measure and record amount of side play of differential case by moving back and forth with a screwdriver (see illustration). The measurement will be used later to determine proper shim pack dimension. Remove case from housing.

Pinion Depth & Bearing Preload — 1) Pinion is adjusted by shims placed between inner bearing cup and housing, and by shims placed between pinion shaft shoulder and outer bearing. Shims behind inner bearing cup adjust position of pinion in relation to ring gear. Shims behind outer bearing adjust pinion inner and outer bearing preload.

2) If old pinion and ring gear assembly are used, proceed as follows: Install original shims and inner bearing cup. Install outer bearing cup. Press bearing cone onto pinion shaft and install shaft into housing. Install outer bearing cone, companion flange, and nut. Do not install outer shims or seal at this time. Tighten nut to obtain bearing preload of 10-30 ft. lbs. Use a suitable gauge to measure distance from ring gear center to machined button on end of pinion gear. Add or subtract shims from under inner bearing cup to obtain nominal dimension listed in specifications.

3) If new pinion and ring gear assembly are to be installed, proceed as follows: Determine pinion depth adjustment figure (see illustration) of old and new pinions and find shim adjust-

DANA/SPICER FULL-FLOATING AXLES (Cont.)

ment figure from chart. Adjust original shim pack accordingly and proceed as in step 2).

4) Remove pinion flange and nut, and remove front pinion bearing cone. Install original preload shim pack. Lubricate and install bearing cone. Install pinion flange and nut and tighten to specifications while rotating pinion shaft. Place housing in position so that pinion shaft is vertical, pointing up. With INCH lb. wrench rotate shaft through several revolutions to measure rotating torque. **NOTE** — Ignore torque needed to start shaft rotating. Check measurement against pinion bearing preload in specifications. To decrease preload, add shims; to increase preload; subtract shims. After adjustment is made, install oil seal and recheck pinion depth.

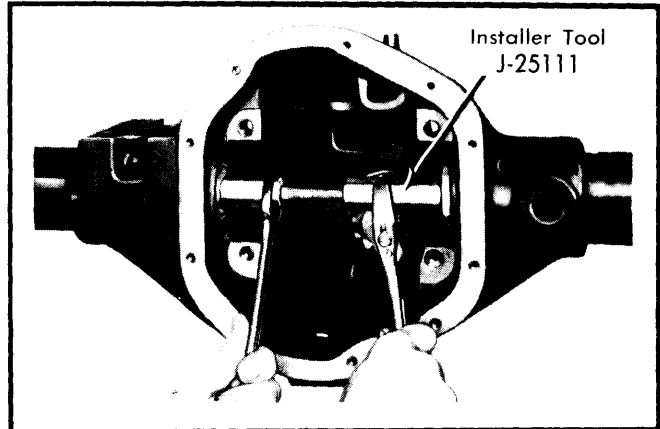

Fig. 8 Correct Procedure for Installing Inner Oil Seals

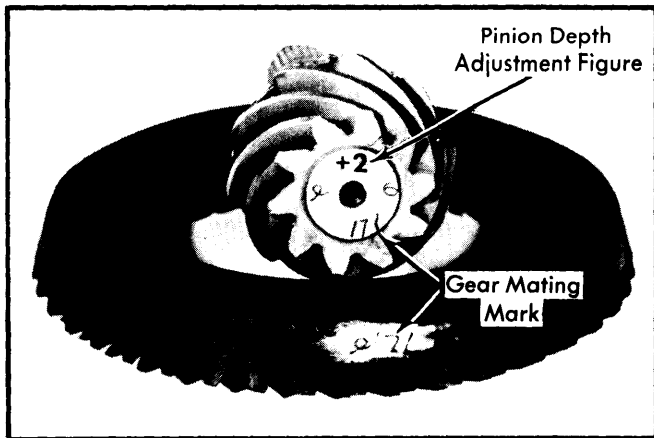

Fig. 7 Pinion and Ring Gear Markings Showing Pinion Depth Adjustment Figure

Side Bearing Preload — 1) With pinion installed in housing and depth and preload adjustments properly made, install differential case into housing and set dial indicator so that it reads at back of ring gear. Leave bearing cap bolts loose enough to allow movement of case. Insert screwdriver between bearing cap and housing at opposite end from ring gear. Jam case toward ring gear side and, with force still applied to case, set dial indicator to zero. Jam case the other way (making sure that ring and pinion gears mesh) and record reading. Repeat several times until readings are the same. This reading is amount of shims that will go between case and bearing on ring gear side. Install these shims.

2) From the figure originally recorded under Case Assembly, subtract amount of shims just installed on case. Add .015" for bearing preload and install new shim pack on end of case opposite ring gear.

Example: +.070" (Original Recorded Sideplay)
 −.032" (Sideplay With Pinion Installed)
 =.038" (Amount Left From Original Sideplay)
 +.015" (Additional Amount For Bearing Preload)
 =.053" (Amount Installed Opposite of Ring Gear)

5) Front axles only: Check seals in axle housing bores. If condition is questionable, replace using suitable installer tool (see illustration). **NOTE** — When installing front axle shafts be sure that these seals are not dislodged.

PINION DEPTH SHIM ADJUSTMENT CHART (INCHES)

Old Pinion	New Pinion								
	−4	−3	−2	−1	0	+1	+2	+3	+4
+4	+0.008	+0.007	+0.006	+0.005	+0.004	+0.003	+0.002	+0.001	0
+3	+0.007	+0.006	+0.005	+0.004	+0.003	+0.002	+0.001	0	−0.001
+2	+0.006	+0.005	+0.004	+0.003	+0.002	+0.001	0	−0.001	−0.002
+1	+0.005	+0.004	+0.003	+0.002	+0.001	0	−0.001	−0.002	−0.003
0	+0.004	+0.003	+0.002	+0.001	0	−0.001	−0.002	−0.003	−0.004
−1	+0.003	+0.002	+0.001	0	−0.001	−0.002	−0.003	−0.004	−0.005
−2	+0.002	+0.001	0	−0.001	−0.002	−0.003	−0.004	−0.005	−0.006
−3	+0.001	0	−0.001	−0.002	−0.003	−0.004	−0.005	−0.006	−0.007
−4	0	−0.001	−0.002	−0.003	−0.004	−0.005	−0.006	−0.007	−0.008

Drive Axles

DANA/SPICER FULL-FLOATING AXLES (Cont.)

3) Install spreader to housing, spread housing and install differential case. **NOTE** — Do not spread housing more than .020". Permanent damage to housing could result. Install differential assembly. Remove spreader and install bearing caps. Make sure that caps are in original position, then tighten caps evenly.

Backlash & Final Assembly — Mount dial indicator to housing and measure ring gear to pinion gear backlash in three places around ring gear (see specifications). Variation between readings should not exceed .002". Adjust to specifications by moving shims from one side of differential case to other, or by changing depth of pinion gear. Check tooth contact pattern (see Tooth Contact Pattern in this section). Install cover and tighten bolts to specifications.

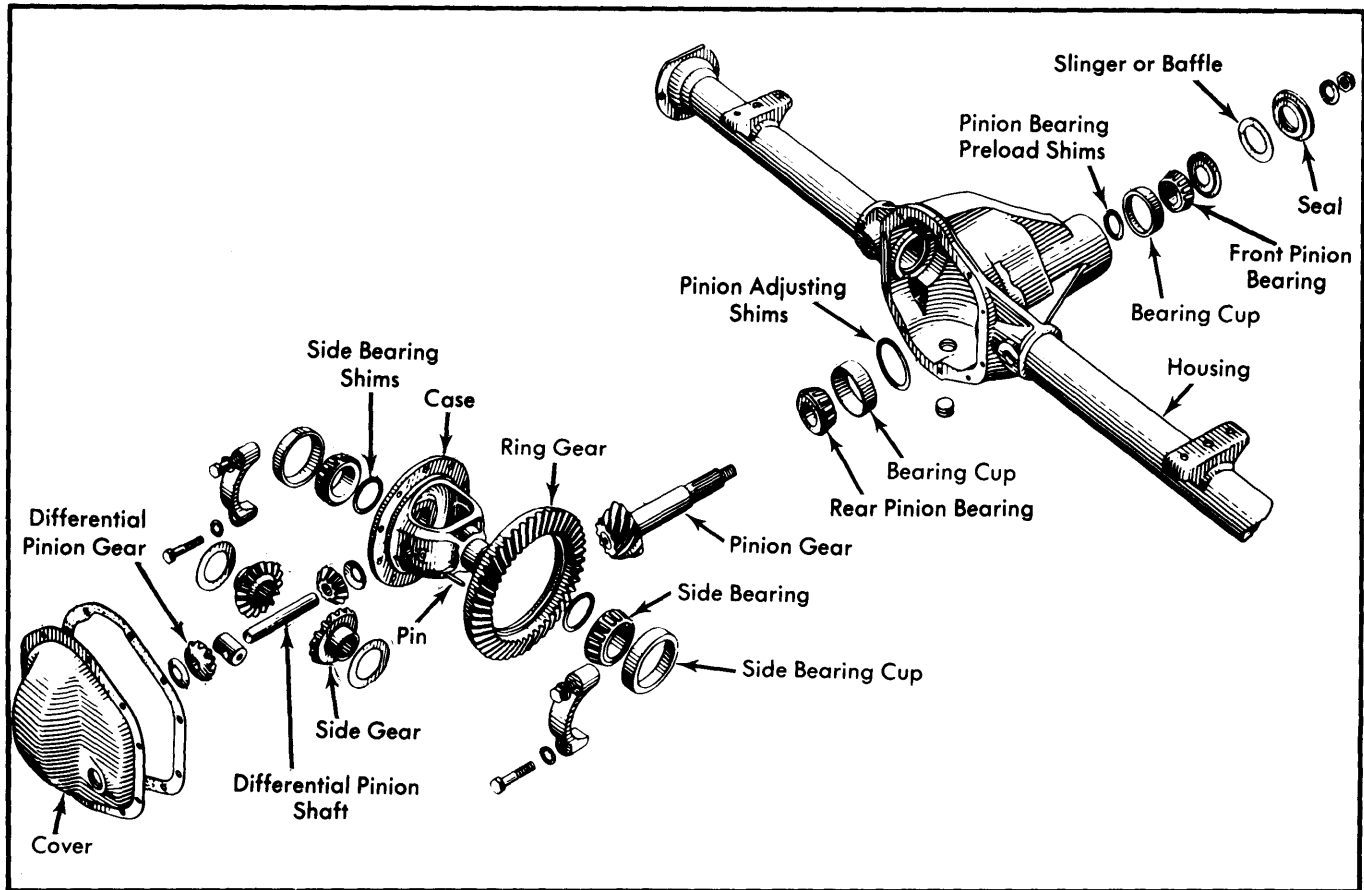

Fig. 9 Exploded View of Dana/Spicer Full-Floating Assembly (One-Piece Differential Shown)

AXLE ASSEMBLY SPECIFICATIONS

Application	Specification
Ring Gear Backlash	.005-.009"
Side Bearing Preload	.015"
Pinion Bearing Preload	
New Bearings	20-40 INCH Lbs.
Used Bearings	10-20 INCH Lbs.
Pinion Gear Depth (Nominal Dimension)	
Model 30	2.250"
Model 44	2.625"
Model 60	3.125"
Model 70	3.500"

TIGHTENING SPECIFICATIONS

Applications	Ft. Lbs. Models 30 & 44	Ft. Lbs. Models 60 & 70
Pinion Shaft Flange Nut	210	260
Side Bearing Cap		
All (Exc. Model 30)	80	80
Model 30	45	
Ring Gear-to-Case	55	110
Axle Flange-to-Hub		
All (Exc. Model 70)	35	55
Model 70		85
Cover-to-Housing	35	40