

258" 6 CYLINDER ENGINE

IDENTIFICATION CODING

ENGINE IDENTIFICATION

Engine Code number is stamped on a machined surface on right side of cylinder block between number two and three cylinders. Letter contained in code identifies engine cubic inch displacement, carburetor type and compression ratio.

Application	Code
258" (4.2L) 2-Bbl.	C

SPECIAL ENGINE MARKS

Some engines are produced at factory with oversize or undersize components. These engines are identified by a letter code stamped on a boss between ignition coil and distributor. Letters are decoded as follows:

- B - All cylinder bores .010" oversize.
- C - All camshaft bearing bores .010" oversize.
- M - All main bearing journals .010" undersize.
- P - All connecting rod journals .010" undersize.

ENGINE REMOVAL

See Engine Removal at end of ENGINE Section.

CYLINDER HEAD & MANIFOLDS

INTAKE & EXHAUST MANIFOLDS

Removal - 1) Remove air cleaner and carburetor. Disconnect fuel line and carburetor air horn vent hose and solenoid wire. Disconnect throttle cable from bellcrank, disconnect throttle valve rod (if equipped).

2) Disconnect PCV hose at manifold. Remove CTO vacuum lines and disconnect wiring at TCS solenoid (if equipped). Disconnect vacuum hose from EGR valve. Disconnect Air Guard hoses at air pump and at air injection manifold check valve. Disconnect diverter vacuum hose and remove diverter.

3) If equipped with power steering, remove pump and bracket and position off to side. If equipped with air conditioning, remove drive belt idler assembly. Disconnect exhaust pipe at manifold flange.

4) Remove manifold retaining nuts and remove intake and exhaust manifolds as a unit. With manifold removed, separate both at heat riser.

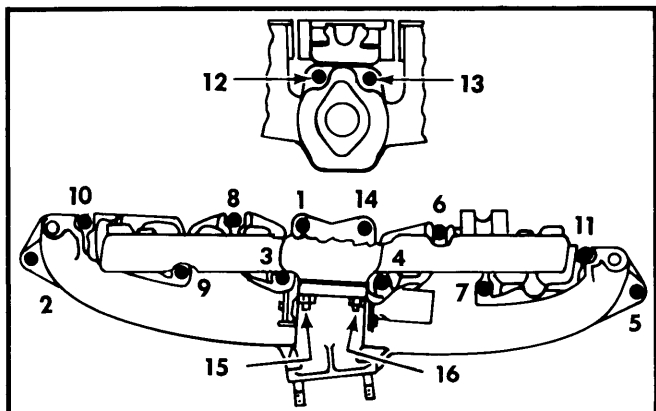

Fig. 1 Intake Manifold Tightening Sequence

Installation - 1) Clean mating surfaces of manifolds and cylinder head. Place exhaust manifold over studs on head. Install bolt number 14 and tighten finger tight. See Fig. 1.

NOTE - No gasket is used between the exhaust manifold and cylinder head. The asbestos gasket is no longer used between intake and exhaust manifolds.

2) Install intake manifold gasket and manifold over dowel pins. Install bolts 12, 13, 15 & 16 finger tight. Install remaining bolts and 2 end nuts.

NOTE - Bolts 12, 13, 15 & 16 are specially hardened and cannot be substituted.

3) Tighten all bolts and nuts in sequence as follows: Positions 1 - 11, tighten to 23 ft. lbs.; positions 12 & 13, tighten to 50 ft. lbs.; position 14, tighten to 23 ft. lbs.; positions 15 & 16, tighten to 35 ft. lbs.

CYLINDER HEAD

Removal - 1) Drain cooling system and disconnect radiator hose at thermostat housing. Remove rocker arm cover. Remove rocker arms and bridged pivot assembly by backing each screw off one turn at a time to avoid damage to bridge, then remove push rods. Remove intake and exhaust manifold assembly from cylinder head.

NOTE - Retain push rods, bridged pivots and rocker arms in order for reinstallation in original location.

2) If equipped with air conditioning, remove drive belt idler bracket from cylinder head. Remove compressor mounting bracket bolts and position compressor and mount off to side without disconnecting lines. Remove spark plugs and disconnect temperature sending unit wire. Disconnect battery ground cable. Remove ignition coil and bracket. Remove cylinder head bolts, cylinder head and gasket.

Installation - Clean gasket mounting surfaces. Coat head gasket with suitable sealer and position on block with word "TOP" facing upward. Install cylinder head and bolts. Tighten bolts in sequence. See Fig. 2.

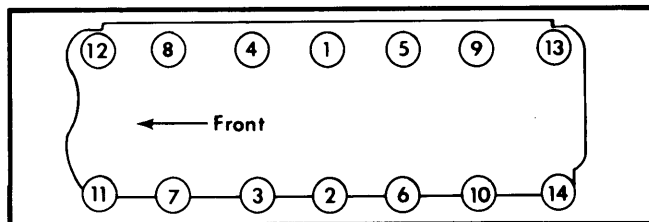

Fig. 2 Cylinder Head Tightening Sequence

VALVES

VALVE ARRANGEMENT

E-I-I-E-I-E-E-I-E-I-I-E (front to rear).

VALVE GUIDE SERVICING

Valve guides are integral with cylinder head. If valve stem-to-guide clearance is not within specifications, ream guide to install valves with oversized stems. Reface valve seat and use

258" 6 CYLINDER ENGINE (Cont.)

suitable tool to break sharp corner (ID) of guide after reaming for oversize valve stems.

CAUTION — Ream valve guides in steps, starting with .003" reamer and progressing to size ream required.

VALVE STEM OIL SEALS

A nylon oil deflector is used on all valves. Oil seals should be replaced any time valve service is performed or seal has deteriorated. Replace using a $\frac{7}{16}$ " deep socket and a light mallet to seat seal on stem.

VALVE SPRINGS

Removal — 1) With rocker cover removed, remove rocker arms and bridged pivot assemblies by backing each screw off one turn at a time to avoid damage to bridge, then remove push rods.

NOTE — Retain push rods, bridged pivots, and rocker arms in order for reinstallation in original location.

2) Apply air pressure to cylinder to hold valves in place, using a suitable adapter installed in spark plug hole. Using a spring compressor tool (J-22534-1, 4 & 5) compress valve spring and remove valve keepers.

3) Remove valve spring and retainer. Remove valve stem oil deflector.

Installation — Use suitable valve spring tester to test valve springs, and replace those that are not within specifications. Reverse removal procedures while noting following: Valve springs must be installed with closed coil end facing cylinder head. Tap spring from side-to-side to be certain spring is seated properly at cylinder head after valve locks are installed. Do not overcompress spring as damage may result to oil deflector. Push rods must be reinstalled in original position.

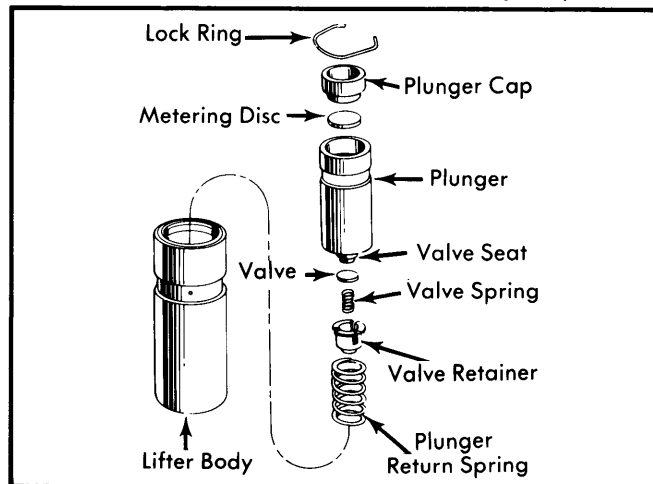

Fig. 3 Exploded View of Hydraulic Valve Lifter Assembly

HYDRAULIC VALVE LIFTER ASSEMBLY

Lifters are serviced as complete assemblies only and parts are not interchangeable between lifters. Inspect for signs of scuffing on barrel and face of tappet body. Inspect tappet face for concave wear and if present, replacement of camshaft and tappets is necessary. If lifters are disassembled for cleaning

and inspection, after reassembly (see illustration for arrangement of parts), they should be tested using suitable leak-down tester according to manufacturers instructions. Leak-down should take 20-110 seconds with a load travel of .125". Discard tappets not within specifications.

NOTE — Do not fill tappet assemblies with engine oil prior to installation as they will charge themselves within 3-8 minutes of engine operation.

ROCKER ARM ASSEMBLY

Both intake and exhaust rocker arms for individual cylinders are on a bridged pivot connected to cylinder head by two screws. Rocker arms are removed by removing screws and lifting rocker arms and pivot from cylinder head. Mark or position rocker arms and pivots to ensure that they are installed in original position. Check pivot surface on rocker arm and pivot for wear or scoring. Check valve contact surface on rocker arm for wear or scoring. To install, reverse removal procedure.

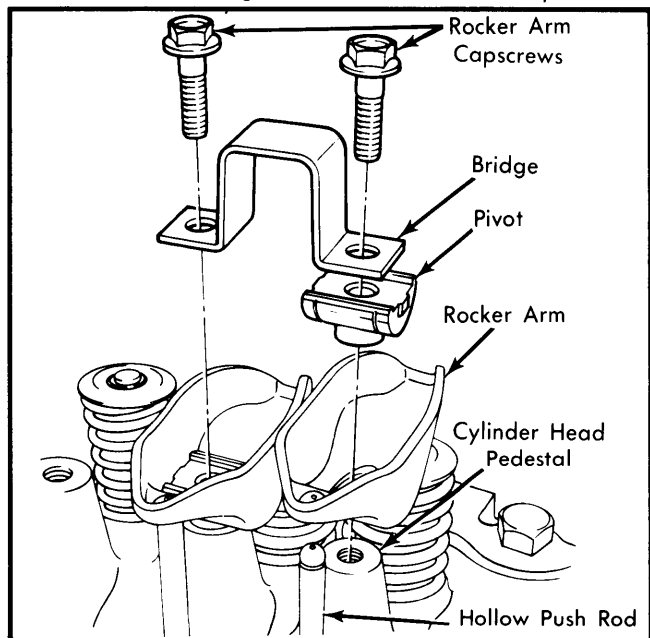

Fig. 4 Detailed View of Rocker Arm Assemblies

PISTONS, PINS & RINGS

OIL PAN

See Oil Pan Removal at end of ENGINE Section.

PISTON & ROD ASSEMBLY

NOTE — New pistons must be installed in same cylinders for which they were fitted, and used pistons in same cylinder from which they were removed.

Removal — 1) With cylinder head and oil pan removed, use ridge reamer to remove any ridge or deposits on upper end of cylinder bore.

NOTE — Piston must be at bottom of stroke and covered with cloth to collect cuttings.

2) Remove connecting rod bearing caps and retain in same order as removed. Install rubber hose over connecting rod studs to protect cylinder walls and push piston and rod assembly out top of cylinder block.

258" 6 CYLINDER ENGINE (Cont.)

NOTE — Caps and rods are stamped with corresponding cylinder number.

Installation — 1) Piston rings must be positioned as follows: No. 1 compression ring gap must be 180° from No. 2 compression ring gap. Oil control ring spacer expander gap must be at least 90° from No. 2 compression ring gap. Oil control ring gaps must be 90° from expander gap. Ring gaps may vary $\pm 20^\circ$ from these positions. Upper and lower compression ring markings indicate top side of ring.

2) Lightly coat pistons, rings and cylinder walls with engine oil. Install suitable ring compressor on pistons, making certain ring gap positions do not change. With connecting rod studs covered for cylinder wall protection, install each piston and rod assembly (with arrow on piston head toward front of engine) in its respective bore. Guide connecting rod onto crankshaft journal while tapping piston head with hammer handle to seat connecting rod against crankshaft. Install mating rod cap and tighten rod cap nuts.

FITTING PISTONS

With piston removed and cylinder bore clean, check bore with a micrometer for taper or out-of-round conditions. If cylinder tapers more than .005" or is out-of-round more than .003", cylinder must be bored and oversize pistons and rings installed. Check piston-to-bore clearance by measuring piston diameter at right angles to piston pin hole, and measuring cylinder bore approximately $2\frac{5}{16}$ " below top of cylinder bore. Difference between two measurements is clearance. If clearance exceeds specifications, cylinder must be bored and oversize pistons and rings installed.

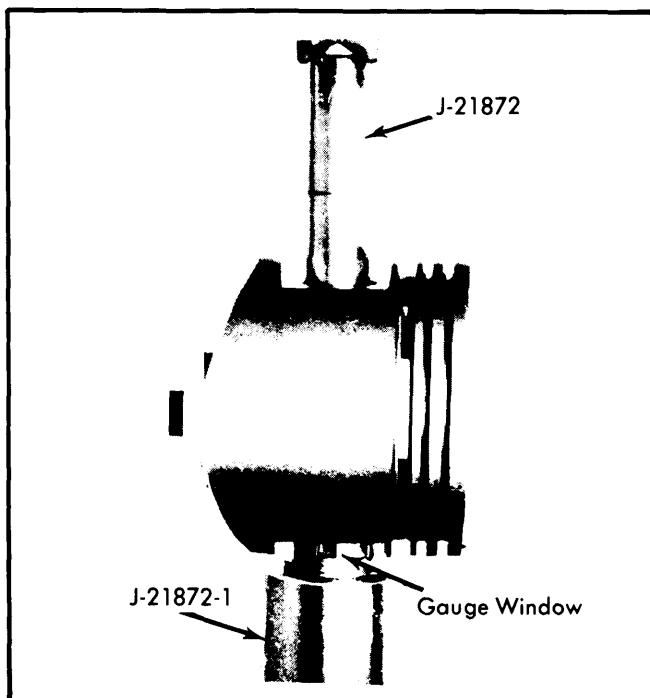

Fig. 5 Piston Pin Removal & Installation

PISTON PINS

Removal — Place piston on suitable support and using suitable tool (J-21872) press pin from piston and rod with arbor press. Note position of pin through gauge window of remover support.

Installation — Using pilot, driver and support (J-21872), press piston pin through connecting rod and piston until pin pilot indexes with mark on support. Pin should be centered in rod plus or minus $\frac{1}{32}$ ".

NOTE — If little effort is required to install piston pin in connecting rod, or if rod moves along pin, a new connecting rod is required. Check piston for freedom of movement on pin.

MAIN & CONNECTING ROD BEARINGS

NOTE — Following procedure is with oil pan removed.

Connecting Rod Bearings — After ensuring rod caps are marked for cylinder identification, remove rod caps. Use Plastigage method to check for proper bearing clearances. If not within specifications new bearings must be installed. New bearings are available in standard, .001", .002", .010" and .012" undersize. Selective fitting is required on each connecting rod. Standard bearing may be used in combination with a .001" undersize, or a .002" undersize in combination with a .001" undersize. See *Connecting Rod Fitting Chart*.

NOTE — Never use a new bearing with a used bearing. Never use a pair of bearings with more than .001" difference in size on same journal.

Main Bearings — 1) Support crankshaft at counterweight adjacent to main bearing being checked and ensure that all bearing caps other than the one being checked are tight. Starting with rear main bearing cap and working forward, remove one cap at a time and check bearing clearances using Plastigage method.

2) If clearances are not within specifications, bearings are available in standard, .001", .002", .010" and .012" undersize. Selective fitting is required on each main bearing. Standard bearing may be used in combination with a .001" undersize, or a .002" undersize in combination with a .001" undersize.

NOTE — Never use a new bearing with a used bearing. Never use a pair of bearings with more than .001" difference in size on same journal.

3) Remove all upper bearings by inserting suitable tool in oil hole of crankshaft journal and rotating crankshaft clockwise to roll bearing from engine. Oil new bearing and rotate crankshaft so bearing will rotate in direction of its locating tang. Install bearing cap with lower bearing and tighten bolts.

THRUST BEARING ALIGNMENT

When replacing thrust bearings (located at No. 3 main bearing journal), crankshaft should be moved fore and aft to align thrust faces of bearings.

258" 6 CYLINDER ENGINE (Cont.)

REAR MAIN BEARING OIL SEAL

Removal — Remove oil pan and rear main bearing cap. Loosen all remaining main bearing bolts. Using a brass drift, tap upper seal until seal is protruding enough to permit pulling it out completely. Remove lower seal from bearing cap.

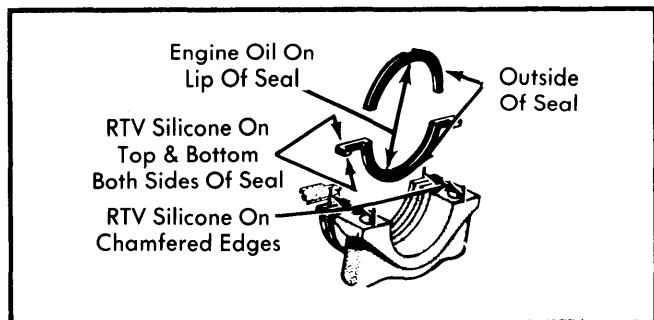

Fig. 6 Exploded View of Rear Main Bearing Oil Seal

Installation — Reverse removal procedure while noting following: Lip of seal must face front of engine. Make sure seal is firmly seated in bearing cap recess. Use suitable sealer and apply as indicated in illustration.

CAMSHAFT

ENGINE FRONT COVER

Removal — Remove drive belt(s), fan and hub assembly, accessory pulley (if equipped) and vibration damper. Remove oil pan-to-timing chain cover screws and cover-to-block screws. Raise cover enough to detach retaining tips of oil pan seal from bottom side of cover. Remove cover and gasket from engine. Cut off oil pan seal end tabs flush with front face of cylinder block and remove seal.

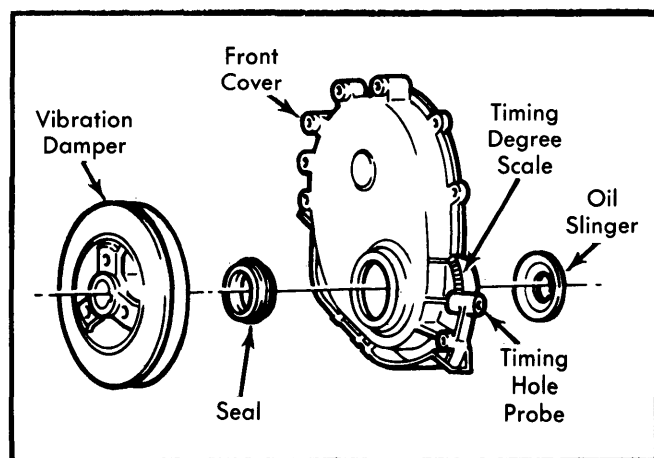

Fig. 7 Exploded View of Engine Front Cover Assembly

Installation — Clean all gasket mounting surfaces. Apply suitable sealing compound to both sides of cover gasket and position on cylinder block. Cut end tabs of a new oil pan seal

flush with front face of cylinder block and position seal on cover using suitable sealer on seal end tabs. Position engine front cover on cylinder block. Use suitable tool to align front cover, and install cover-to-block screws and oil pan-to-cover screws. Tighten all screws. Remove alignment tool. Install vibration damper, pulley, fan and hub assembly, and drive belt(s).

FRONT COVER OIL SEAL

Removal & Installation — Remove drive belt(s), accessory drive pulley and vibration damper. Remove oil seal using tool (J-9256). To install new seal, apply light film of suitable sealer on outside diameter of seal and position on cover with seal lip facing outward. Use alignment and seal installation tool (J-22248) with screw from tool (J-9163) to press seal into cover until it bottoms. Apply light film of engine oil on seal lip and install vibration damper, accessory drive and drive belt(s).

TIMING CHAIN

Removal — Remove engine front cover. Remove camshaft sprocket retaining bolt and washer. Rotate crankshaft until timing mark on sprocket is aligned with camshaft sprocket timing mark (see illustration). Remove sprockets and timing chain as an assembly.

Installation — Assemble timing chain, crankshaft sprocket, and camshaft sprocket with timing marks aligned (see illustration). Install assembly to crankshaft and camshaft. Install camshaft sprocket retaining bolt and washer, then tighten.

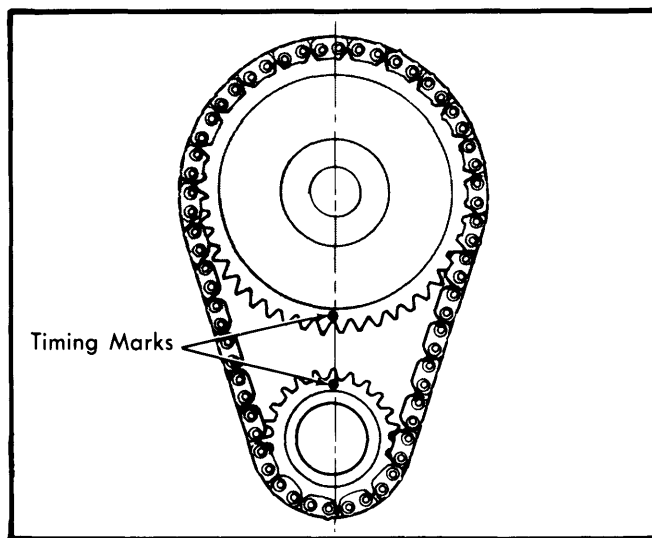

Fig. 8 Timing Chain Sprocket Alignment

CAMSHAFT

Removal — Remove radiator, cylinder head, hydraulic lifters, engine front cover, and timing chain. Remove fuel pump, distributor and ignition wires. Remove front bumper or grille as required and carefully remove camshaft.

Installation — Reverse removal procedure while noting following: Lubricate camshaft with suitable oil supplement and install camshaft carefully to avoid damage to camshaft lobes.

258" 6 CYLINDER ENGINE (Cont.)

CAMSHAFT BEARINGS

NOTE — When installing cam bearings, use a screw-type cam bearing installation tool, one that provides steady pressure. Do Not use a driver-type cam bearing installation tool.

CAM LOBE LIFT

Remove rocker arm cover, rocker arms and pivots. Remove spark plugs and proceed as follows:

1) Using suitable clamping or mounting fixture, attach dial indicator to cylinder head so indicator probe rests on top of push rod with indicator and probe in a vertical position over push rod.

CAUTION — If using an auxiliary starter switch, distributor primary lead must be disconnected from negative post of coil.

2) Rotate crankshaft slowly until valve lifter is on heel of cam lobe. At this point, push rod will be at its lowest point.

3) With push rod at lowest position, zero dial indicator and rotate engine until push rod is in fully raised position. Compare total lift recorded with specifications. If less than specifications, camshaft is defective. Check all remaining lobes of camshaft in same manner.

VALVE TIMING

Remove spark plugs, rocker arm cover, and rocker arms and bridged pivot from No. 1 cylinder. Rotate crankshaft until No. 6 piston is at TDC on compression stroke. Rotate crankshaft counterclockwise 90°. Install dial indicator with indicator point touching No. 1 cylinder intake push rod, then set dial indicator to zero. Rotate crankshaft clockwise until dial indicator shows .016" lift. Timing mark on vibration damper should index with TDC mark on engine front cover. If timing mark is more than 1/2" off TDC in either direction, valve timing is incorrect.

ENGINE OILING

Crankcase Capacity — Engine takes 4 qts., add 1 quart with filter change.

Oil Filter — Replace every 5000 miles or 5 months, whichever comes first. When installing new filter, tighten by hand only. Filter system is full-flow type mounted on right side of crankcase.

Normal Oil Pressure — Minimum 13 psi at 600 RPM, 37-75 psi Maximum at 1600 RPM and above.

Pressure Regulator Valve — Located in pump body. Not adjustable.

ENGINE OILING SYSTEM

Oil under pressure is directed from gear type oil pump to a full-flow oil filter. In case filter becomes clogged and restricts full flow of oil, a by-pass valve is located in filter mounting base. From oil filter, oil flow is directed as follows:

Crankshaft & Camshaft Bearings — Main and camshaft bearings receive oil from main oil gallery. From main bearings oil passes through passage in crankshaft to connecting rod bearings. Oil throw-off from each connecting rod bearing lubricates cylinder walls, piston pins, camshaft lobes and distributor drive gear.

Hydraulic Valve Tappets — Lubricated directly from main oil gallery.

Timing Chain & Sprockets — Oil is received from front camshaft bearing and returns to crankcase through cavity under front main bearing cap.

Rocker Arms & Push Rods — Oil from main oil gallery is fed to hydraulic valve lifters. Lifters meter oil to hollow push rods which lubricate rocker arms and pivots. Holes cast in cylinder head return oil to crankcase through lifter area.

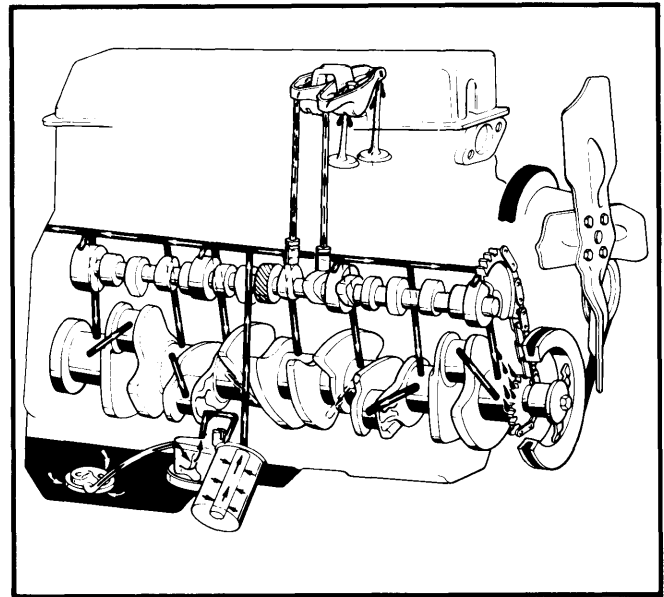

Fig. 9 Engine Oiling System

OIL PUMP

Oil pump is driven by distributor drive shaft. Removal of pump will not affect ignition timing, as distributor gear remains meshed with camshaft gear. Pump must be filled with petroleum jelly prior to installation of oil pump cover.

CAUTION — Oil inlet tube position must be changed to allow removal of relief valve; therefore, pickup tube assembly must be replaced upon installation and suitable sealer used.

258" 6 CYLINDER ENGINE (Cont.)

Oil Pump Specifications

Application	Specifications
Gear-to-Body Clearance0005-.0025"
Gear End Clearance	① .004-.008"
① — With feeler gauge method. Plastigage method; .002-.008".	

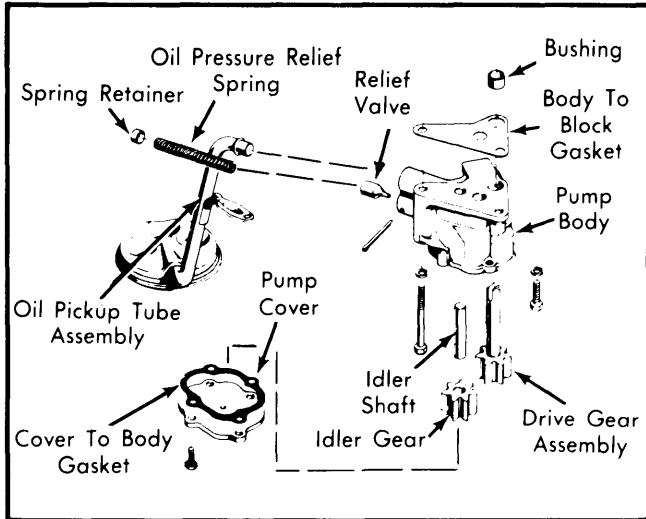

Fig. 10 Exploded View of Oil Pump Assembly

TIGHTENING SPECIFICATIONS

Application	Ft. Lbs.
Camshaft Sprocket	45-55
Clutch Housing-to-Block	
Top	22-30
Bottom	37-47
Connecting Rod Nut	30-35
Cylinder Head	95-115
Drive Plate-to-Converter	20-25
Engine Front Cover	
Screw	4-8
Stud	13-19
Exhaust Manifold Bolt	18-28
Flywheel-to-Crankshaft	95-120
Fuel Pump	13-19
Intake Manifold Bolts	①
Main Bearing Cap Bolts	75-85
Oil Pan	
1/4" Bolts	5-9
5/16" Bolts	9-13
Oil Pump Cover	5-7
Oil Pump Screw	
Short	8-13
Long	12-20
Rocker Arm Capscrews	16-26
Thermostat Housing	10-18
Vibration Damper	70-90
Water Pump Screws	9-18
① — Bolts 1-11 & 14; 23 ft. lbs. Bolts 15 & 16; 35 ft. lbs. Bolts 12 & 13; 50 ft. lbs. See Fig. 1.	

ENGINE SPECIFICATIONS

GENERAL SPECIFICATIONS

Year	Displ. Cu. Ins.	Carburetor	HP at RPM	Torque (Ft. Lbs. at RPM)	Compr. Ratio	Bore	Stroke
1980	258"	2-Bbl.	8.0:1	3.75"	3.895"

VALVES

Engine & Valve	Head Diam.	Face Angle	Seat Angle	Seat Width	Stem Diameter	Stem Clearance	Valve Lift
258"							
Int.①	1.782-1.792"	29°	30°	.040-.060"	.3715-.3725"	.001-.003"	.397"
Exh.①	1.401-1.411"	44°	44.5°	.040-.060"	.3715-.3725"	.001-.003"	.397"

① — Do not remove more than .020" from end of valve stem.

PISTONS, PINS, RINGS

Engine	PISTONS	PINS		RINGS		
	Clearance	Piston Fit	Rod Fit	Rings	End Gap	Side Clearance
258"	.0009-.0017"	.0003-.0005"	Press Fit	1	.010-.020"	.0015-.003"
				2	.010-.020"	.0015-.003"
				3	.010-.025"	.001-.008"

Jeep 6 Engines

258" 6 CYLINDER ENGINE (Cont.)

ENGINE SPECIFICATIONS (Cont.)

CRANKSHAFT MAIN & CONNECTING ROD BEARINGS							
Engine	MAIN BEARINGS			Crankshaft End Play	CONNECTING ROD BEARINGS		
	Journal Diam.	Clearance	Thrust Bearing		Journal Diam.	Clearance	Side Play
258"	2.4986-2.5001"	.001-.003"	No. 3	.0015-.0065"	2.0934-2.0955"	.001-.0025"	.005-.014"

MAIN BEARING FITTING CHART		
Main Bearing Journal Color Code & Diameter	Bearing Color & Size Code Upper Insert	Bearing Color & Size Code Lower Insert
Yellow 2.4996-2.500"	Yellow Std.	Yellow Std.
Orange 2.4991-2.4996"	Yellow Std.	Black -.001"
Black 2.4986-2.4991"	Black -.001"	Black -.001"
Green 2.4981-2.4986"	Black -.001"	Green -.002"
Red 2.4896-2.4901"	Red -.010"	Red -.010"

CONNECTING ROD BEARING FITTING CHART		
Connecting Rod Journal Color Code & Diameter	Bearing Color & Size Code Upper Insert	Bearing Color & Size Code Lower Insert
Yellow 2.0948-2.0955"	Yellow Std.	Yellow Std.
Orange 2.0941-2.0948"	Yellow Std.	Black -.001"
Black 2.0934-2.0941"	Black -.001"	Black -.001"
Red 2.0848-2.0855"	Red -.010"	Red -.010"

VALVE SPRINGS			
Engine	Free Length	PRESSURE (LBS.)	
		Valve Closed	Valve Open
258"			
Int.	1.99"	64-72 @ 1.786"	188-202 @ 1.411"
Exh.	1.99"	80-88 @ 1.625"	210-226 @ 1.188"

VALVE TIMING				
Engine	INTAKE		EXHAUST	
	Open (BTDC)	Close (ABDC)	Open (BBDC)	Close (ATDC)
258"	14.58°	68.79°	55.59°	27.78°

CAMSHAFT			
Engine	Journal Diam.	Clearance	Lobe Lift
258"			
No.1	2.029-2.030"	.001-.003"	.248"
No.2	2.019-2.020"		
No.3	2.009-2.010"		
No.4	1.999-2.000"		