

General Motors 6 Engines

250" & 292" 6 CYLINDER ENGINES

IDENTIFICATION CODING

ENGINE IDENTIFICATION

Engines have a portion of the vehicle identification number and build date code stamped on cylinder block. Number for 6 cylinder engine is stamped on pad located on right side of block next to distributor. Third character is engine code.

Application	Chevrolet & GMC	
	Man. Trans.	Auto. Trans.
250" (4.1L) 2-Bbl.		
Federal	TAB, TAC	TCA, TCB, TCJ
Calif.	TAF, TAH,	TCC, TCD,
	TAM, TAR	TCF, TCH
292" (4.8L) 1-Bbl.		
All Models	THC, THJ	THF

ENGINE REMOVAL

See *Engine Removal at end of ENGINE Section.*

CYLINDER HEAD & MANIFOLDS

INTAKE & EXHAUST MANIFOLD (292" Engine)

Removal — 1) Remove air cleaner, disconnect both throttle rods at bellcrank and remove throttle return spring. Disconnect fuel line, vacuum lines and choke cable (if equipped) at carburetor. Disconnect crankcase vent hose at rocker arm cover and remove vapor hose at canister.

2) Disconnect exhaust pipe at flange and remove manifold attaching bolts and clamps. Remove intake and exhaust manifold as an assembly.

Installation — Ensure gasket surfaces are clean. Place manifold in position with new gasket, tighten center clamp bolts and then tighten end bolts. Reverse removal procedure to complete installation.

EXHAUST MANIFOLD (250" Engine)

NOTE — Intake manifold on 250" engine is integral with cylinder head.

Removal — 1) Remove air cleaner. Remove power steering pump, A.I.R. pump and brackets. Remove A.I.R. tubing manifold.

2) Raise vehicle and disconnect exhaust pipe. Unhook converter bracket at transmission and lower vehicle. Remove manifold.

Installation — Ensure gasket surfaces are clean and straight. Place manifold in position with new gasket. Install manifold

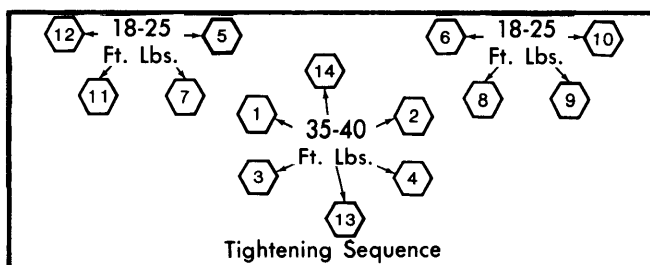

Fig. 1 Exhaust Manifold Tightening Sequence (250" Engine)

bolts and tighten to specification. Reverse removal procedure to complete installation. See *Fig. 1.*

CYLINDER HEAD

Removal — 1) Remove intake manifold as previously outlined. Disconnect temperature sending unit wire from clip on rocker arm cover. Remove air injection hose at check valve of A.I.R. pipe (if equipped) and remove rocker arm cover. Back off rocker arm adjusting nuts, pivot rocker arms to side and remove push rods.

NOTE — On 250" engines, disconnect exhaust pipe at manifold.

2) Drain cooling system and remove fuel and vacuum line from clip at water outlet. Disconnect radiator hose at water outlet and battery ground strap. Remove coil and disconnect spark plug wires. Remove cylinder head bolts and remove cylinder head.

Installation — Ensure that gasket surface on cylinder head and block are clean and all head bolt threads and threads in block are clean. To install cylinder head, reverse removal procedure. Do not apply sealer to composition steel asbestos gaskets. Coat threads of head bolts with sealer. Tighten bolts in sequence as shown in *Fig. 2.* Install push rods and adjust hydraulic valve lifters. See *Hydraulic Valve Lifter Adjustment.*

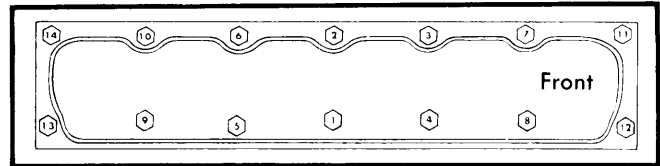

Fig. 2 Cylinder Head Tightening Sequence

VALVES

VALVE ARRANGEMENT

E-I-I-E-E-I-I-E-E-I-I-E (Front to rear.)

VALVE GUIDES

Valve guides are integral with cylinder head. If guide is worn, it must be reamed for valve with oversize stem. Valves are available with stems .003, .015 and .030" oversize. Use suitable reamers to ream valve guide bore to specified clearance for oversize stems.

VALVE STEM OIL SEALS

A small "O" ring type seal is installed in second groove in valve stem before valve keepers are installed. See *Valve Springs.*

VALVE SPRINGS

Removal — With cylinder head removed, compress valve spring with a suitable spring compressor. Remove valve keepers and release spring compressor. Remove spring retainer (valve rotating retainer is used on exhaust valves), shield, spring and damper, and any shims under spring.

Installation — To install valve spring, place shims, spring and damper, shield and retainer on the valve stem. Compress the spring with a spring compressor tool. Install new "O" ring type

250" & 292" 6 CYLINDER ENGINES (Cont.)

seal in second groove on valve stem. Install valve keepers in upper groove on valve stem and release spring compressor.

NOTE — Damper is not used on 250" engine.

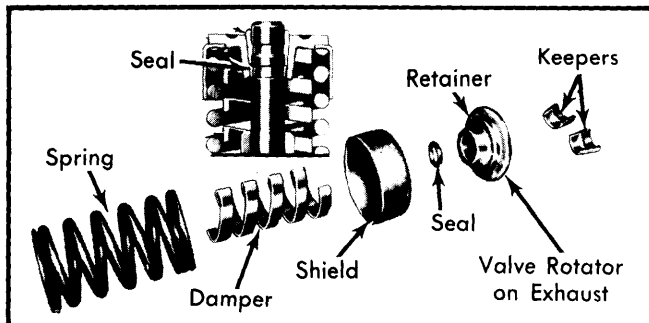

Fig. 3 Exploded View of Valve Spring Assembly

VALVE SPRING INSTALLED HEIGHT

Using a narrow thin scale, check valve spring installed height by measuring from top of shim or spring seat in head to top of valve spring or shield. If height exceeds specified height, install a $\frac{1}{16}$ " thick shim under spring. Installed height should never be less than specified height.

ROCKER ARM STUDS

Rocker arm studs that are loose in head or have damaged threads can be replaced with oversize studs. Studs are available .003" and .013" oversize.

Removal — Remove stud using suitable stud extractor (J-5802-A). Install extractor over stud and tighten nut until stud is pulled from cylinder head.

Installation — Ream hole for oversize studs with a suitable reamer (J-5715 for .003" oversize and J-6036 for .013" oversize). Coat press fit area of stud with hypoid axle grease. Drive rocker stud into place with a suitable driver (J-6880) and a hammer. When driver bottoms on head, stud is at correct height.

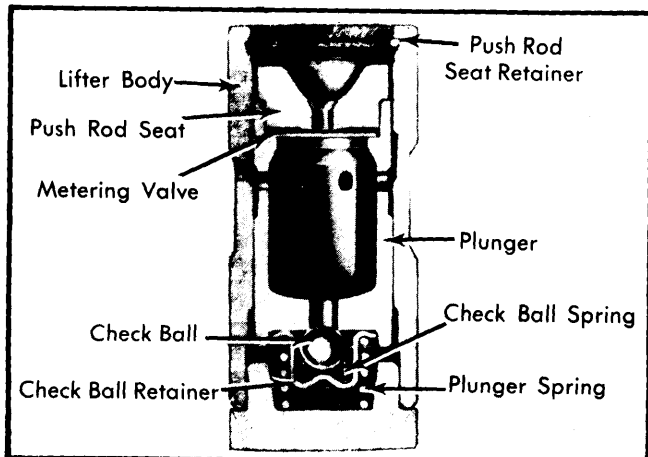

Fig. 4 Cutaway of Hydraulic Valve Lifter Assembly

HYDRAULIC VALVE LIFTER ASSEMBLY

Disassembly — Depress plunger in lifter with a push rod and pry out retainer with a small blade screwdriver. Remove push

rod seat and metering valve. Remove plunger, ball check valve and assembly, and plunger spring. Remove ball check valve and spring by prying ball retainer loose with a small blade screwdriver.

Reassembly — 1) Thoroughly clean and inspect all components. If any components are worn and/or damaged, complete lifter assembly must be replaced.

2) Position check ball on small hole in bottom of plunger. Insert check ball spring on seat in ball retainer and position retainer on ball so that spring seats on ball. Using a screwdriver, press plunger into position.

3) Slide lifter body over spring and plunger, lining up oil feed holes. Fill assembly with SAE 10 oil and depress plunger to stop. With plunger depressed, insert a $\frac{1}{16}$ " drift punch into feed holes. Release plunger and refill with SAE 10 oil. Install metering valve, push rod seat and retainer. Depress push rod seat and remove drift punch.

HYDRAULIC VALVE LIFTER ADJUSTMENT

Rotate engine until rotor is at number 1 cylinder position and points are just opening. With engine at this position, adjust intake valves 1, 2 and 4 and exhaust valves 1, 3 and 5. Back off rocker arm nuts until lash is felt, then tighten nut until all lash is removed and tighten 1 full additional turn. Now rotate engine until rotor is at number 6 position and points are just opening. Following same procedure and adjust intake valves 3, 5 and 6 and exhaust valves 2, 4 and 6.

PISTON, PINS & RINGS

OIL PAN

See *Oil Pan Removal at end of ENGINE Section.*

PISTON & ROD ASSEMBLY

Removal — With oil pan, oil pump and cylinder head removed, remove any ridge in top of cylinder bore with a suitable ridge reamer. Check connecting rod and cap for identification marks or numbers and identify if necessary. Remove connecting rod cap nuts and rod cap. Push piston and rod assembly up and out of cylinder block. It will be necessary to rotate crankshaft to various positions to aid in removing piston and rod assemblies.

Installation — Before installing piston and rod assembly, place ring end gaps in positions shown in illustration. Ensure that cylinder bores are clean and oiled before installing piston and rod assemblies. Lubricate crankshaft journal and rod bearings. Compress piston rings with a suitable ring compressor. Position piston and rod assembly in bore with notch in top of piston facing toward front of engine. Push piston and rod assembly into position carefully aligning bearing on crankshaft. Install connecting rod cap noting identification marks and evenly tighten rod nuts.

FITTING PISTONS

1) With piston and rod assemblies removed, wipe cylinder bore clean and measure diameter with dial indicator. Set gauge so that thrust pin must be forced in $\frac{1}{4}$ " to enter cylinder bore. Center gauge in cylinder and set indicator to zero.

General Motors 6 Engines

250" & 292" 6 CYLINDER ENGINES (Cont.)

2) Work gauge carefully up and down cylinder and turn in different directions to determine out-of-round and taper. Out-of-round must not exceed .002" and taper .005". Cylinder may be honed and .001" oversized pistons installed if measurements do not exceed specifications. Oversized pistons are available if cylinders are bored.

3) To check fit of rings in cylinder bore, insert ring in cylinder bore and push ring into bore 2" with head of piston and measure ring end gap with a feeler gauge. Before installing rings on pistons, ensure ring grooves are clean of carbon and inspect grooves for nicks or burrs. Install rings with gaps positioned as shown. See Fig. 5.

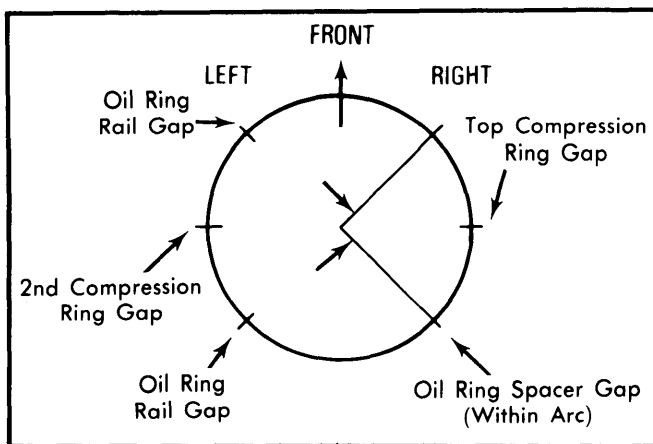

Fig. 5 Desired Ring Gap Locations

PISTON PINS

Removal — With piston and rod assembly removed, press out piston pin using removal and installation tool set J-24086 (or equivalent) and an arbor press. Separate piston from connecting rod.

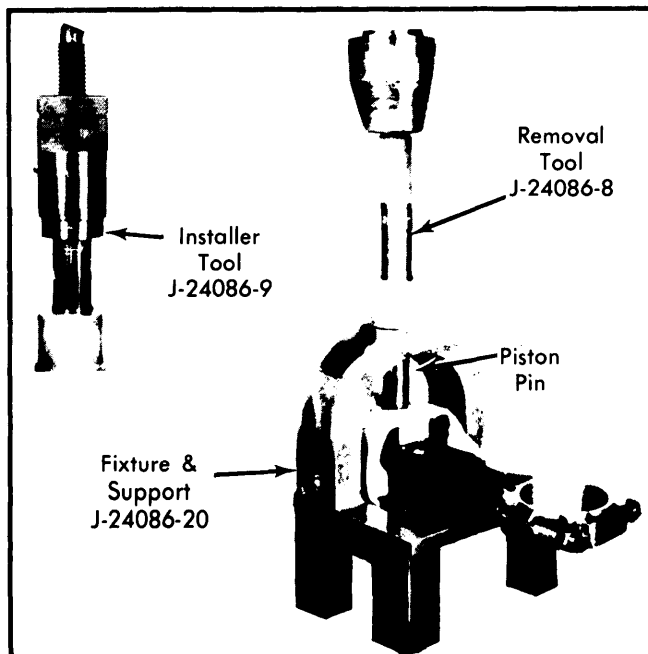

Fig. 6 Removing and Installing Piston Pin

Installation — Check clearance of piston pin in piston. If clearance exceeds .001" over specified clearance, piston and pin must be replaced. Position piston on rod so that bearing tangs face away from camshaft and notch on top of piston is toward front of engine. Lubricate piston pin and press in using same tools as outlined in removal procedure. Check piston for freedom of movement on piston pin.

CRANKSHAFT & ROD BEARINGS

MAIN & CONNECTING ROD BEARINGS

NOTE — Following procedures are performed with oil pan and oil pump removed.

Connecting Rod Bearings — 1) Mark or identify rod cap to rod before removing rod cap nuts. With rod nuts removed, remove rod cap and bearing. Push up on piston and rod assembly and remove bearing from rod. Inspect bearings for wear or damage and replace as necessary.

2) Check crankshaft rod bearing journal for out-of-round or taper conditions. If crankshaft is out-of-round or tapers more than .001", crankshaft must be removed and ground for undersize bearings.

3) Check rod bearing clearance using the Plastigage method. If clearance exceeds specifications, a .001" or .002" undersize bearing may be installed to obtain correct clearance. If clearance is still excessive, crankshaft must be removed and ground for undersize bearings. Connecting rod bearings are available .010" and .020" undersize.

4) To install bearings, clean crankshaft journal and bearing surface in rod. Insert bearing halves in rod and cap. Lubricate journal and pull piston and rod assembly down, aligning bearing on journal. Install rod cap noting identification marks and evenly tighten rod nuts.

Main Bearings — 1) Main bearings are selective fit by manufacturer during production. A standard size bearing half may be used in combination with a .001" undersize bearing half to obtain correct clearance. This combination will decrease clearance .0005".

2) If correct clearance could not be obtained during production, a crankshaft with .009" undersize main bearing journals is fitted. A .009" and .010" bearing half combination may be used to obtain correct clearance.

3) Engines fitted with reground crankshafts may be identified by a "9" stamped on counterweight and a large spot of light green paint next to affected bearing. Also main bearing cap will be painted light green for that bearing.

4) Main bearings may be removed and replaced with crankshaft still installed. Mark or identify main bearing caps to cylinder block before removing caps. With the exception of rear main bearing, main bearings are removed from cylinder block by inserting a bearing removal and installing tool in oil hole in crankshaft and rotating crankshaft clockwise. To remove rear main bearing, drive bearing partly out with a drift punch and hammer. Using a pair of pliers with taped jaws, grab bearing thrust surface and slinger on crankshaft and rotate crankshaft to remove bearing.

250" & 292" 6 CYLINDER ENGINES (Cont.)

5) Crankshaft clearance, taper or out-of-round conditions can be checked using the Plastigage method. If clearance exceeds specifications, a .001" or .002" undersize bearing may be installed to obtain correct clearance. Both bearing halves must be replaced.

6) If correct clearance can not be obtained or if journal is tapered or is out-of-round more than .001", crankshaft must be removed and ground for undersized bearings. Bearings are available in standard, .001", .002", .009", .010" and .020" undersize.

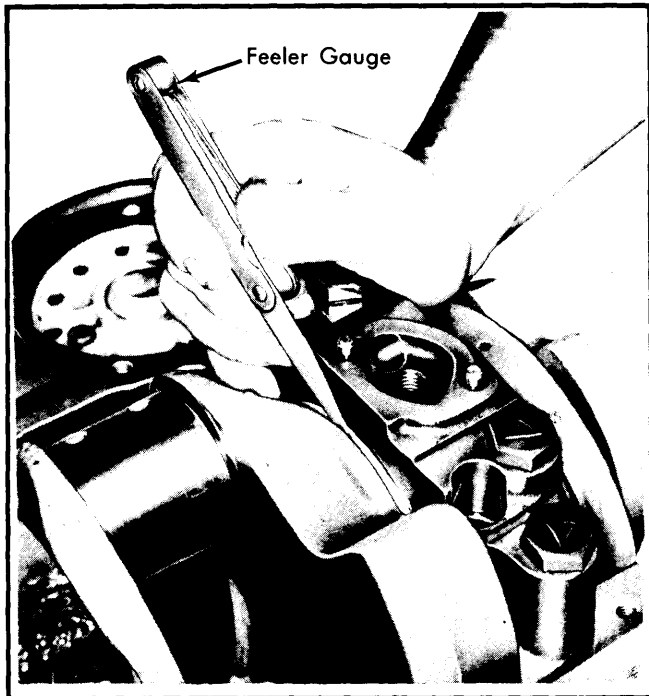

Fig. 7 Using Feeler Gauge to Check Crankshaft End Play

7) To install bearings, ensure crankshaft journal and bearing surface in cap and block are clean. Lubricate journal and install bearing in cap. If bearings were removed with crankshaft still installed, use bearing removal and installation tool inserted in crankshaft oil hole to install upper bearing half. To install rear upper main bearing, place in position and use plier procedure, as previously described, to install bearing. Install main caps noting identification marks and evenly tighten main bearing bolts.

THRUST BEARING ALIGNMENT

Pry crankshaft forward as far as possible and check crankshaft end play with a feeler gauge inserted between front of rear main bearing and crankshaft. Replace rear main bearing if end play not to specifications.

REAR MAIN BEARING OIL SEAL

Removal — Remove rear main bearing cap and pry out old seal. Remove upper half of seal by tapping end with brass punch until end of seal protrudes enough to be removed with pliers.

Installation — 1) Fabricate installation tool as shown in illustration. Coat seal lips and seal bead of upper seal with motor oil. Keep ends of seal dry of oil and position tool between crankshaft and seal seat in cylinder block. Position seal between tip of tool and crankshaft.

2) Roll seal around crankshaft, using tool as a "shoehorn" to protect seal from sharp corner of seal seat surface. Make sure that oil seal lip is positioned towards front of engine.

NOTE — Installation tool must remain in position until seal is positioned with both ends flush with block. Remove tool taking care not to remove seal.

3) Install lower half of seal in bearing cap, using tool as a "shoehorn". Feed seal into cap using light pressure with thumb and finger. Install bearing cap with sealant applied to face, taking care to keep sealant off of split line.

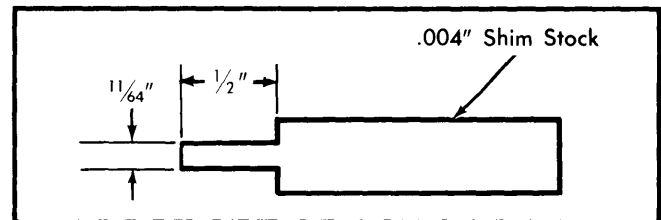

Fig. 8 Rear Main Oil Seal Installation Tool

CAMSHAFT

ENGINE FRONT COVER

Removal — 1) Remove fan belt, fan and pulley. Remove radiator shroud and accessory drive pulley. Remove harmonic balancer pulley bolt (if equipped).

2) Pull off harmonic balancer with suitable puller (J-23523). Remove front cover and oil pan-to-cover retaining screws and remove cover with gasket. Use sharp cutting tool to cut oil pan front seal flush with block.

NOTE — 292" engines do not use front rubber seal. RTV or equivalent is used.

Installation — Make sure that gasket surface on cover and cylinder block are clean. Coat front cover oil seal with oil and install cover with gasket coated with sealer and evenly tighten screws. Install harmonic balancer and pull into position with a suitable puller (J-23523) or drive into position with a suitable driver and a hammer. To install remaining components, reverse removal procedure.

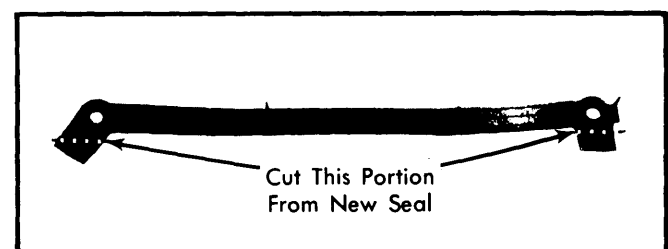

Fig. 9 Oil Pan Front Seal Modification

General Motors 6 Engines

250" & 292" 6 CYLINDER ENGINES (Cont.)

FRONT COVER OIL SEAL

With Cover Removed — Pry seal out of cover with a screwdriver. Install new seal with open end of seal toward inside of cover and drive into position with a suitable driver (J-23042) and a hammer. Support cover at seal area before driving in seal.

With Cover Installed — With harmonic balancer removed, pry seal out front of cover. Install seal with open end of seal toward engine and drive into place with a suitable driver (J-23042) and a hammer.

CAMSHAFT

Removal — 1) Drain cooling system and remove radiator. Remove front grille assembly. Remove valve cover and loosen all rocker arm nuts. Rotate rocker arms to side and withdraw all push rods.

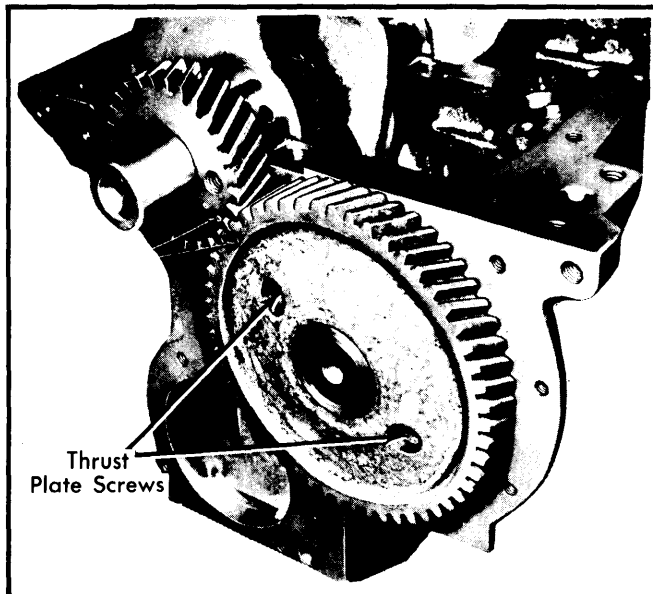

Fig. 10 View Showing Location of Camshaft Thrust Plate Screws

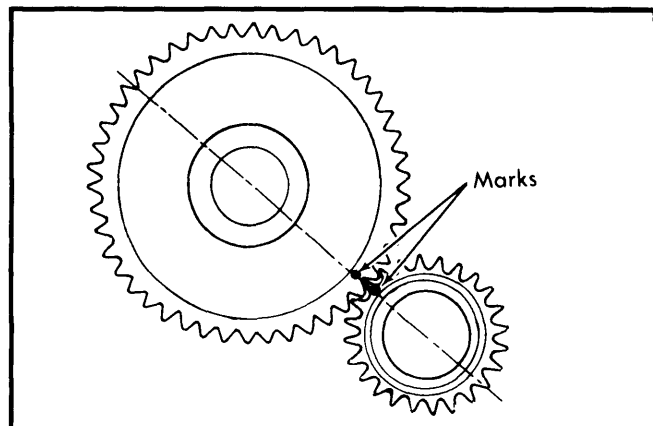

Fig. 11 Alignment of Timing Gear Marks

2) Remove coil, side cover and all valve lifters. Remove front engine cover as previously outlined. Rotate engine until timing marks on camshaft gear and crankshaft gear are aligned. Remove distributor, noting position of rotor. Remove two camshaft thrust plate screws and carefully pull camshaft out front of engine to remove.

Installation — To install camshaft, reverse removal procedure. Carefully install camshaft in cylinder block to prevent damage to camshaft lobes or bearings. Make sure marks on timing gears are aligned (see illustration).

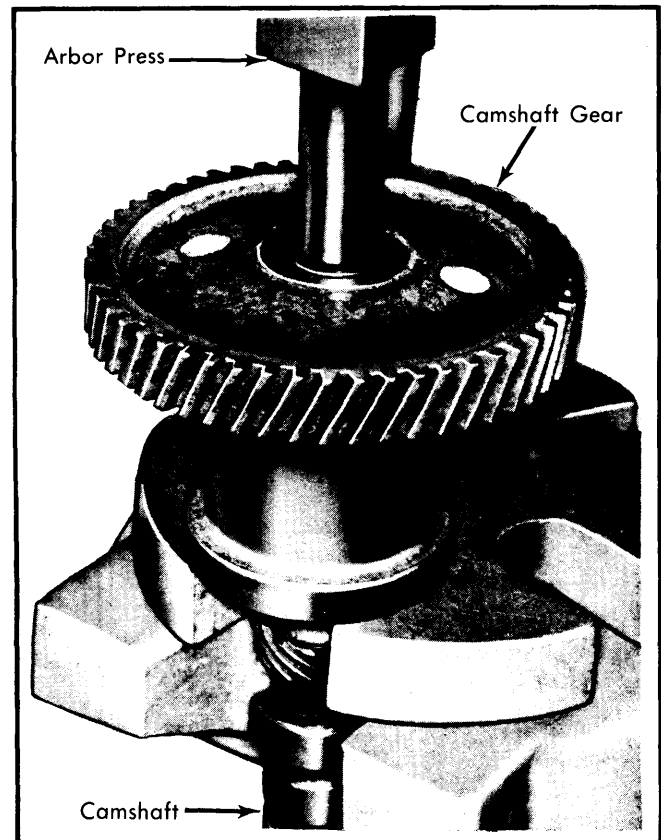

Fig. 12 Pressing Camshaft From Gear

TIMING GEARS

With camshaft installed, check gear backlash with a narrow feeler gauge. If backlash is less than .004" or exceeds .006", timing gears must be replaced. Check both gears for runout with a dial indicator. If camshaft gear runout exceeds .004", or crankshaft gear runout exceeds .003", gears must be replaced.

Removal — With camshaft removed, position camshaft and a suitable mandrel (J-971) in a press and press camshaft out of gear. Make sure thrust plate is positioned so that Woodruff key will not damage it when camshaft is pressed out of gear. To remove crankshaft gear from crankshaft pull off with a suitable puller.

250" & 292" 6 CYLINDER ENGINES (Cont.)

Installation — To install crankshaft gear, align gear on key and drive gear onto crankshaft with a suitable driver. To install camshaft gear, position camshaft in a press with camshaft supported at back of front journal. Place gear spacer ring and thrust plate over camshaft and install Woodruff key in keyway. Press gear onto shaft until clearance between thrust plate and gear is .001-.005".

CAMSHAFT BEARINGS

Removal — 1) With oil pump and pan removed, drive out camshaft rear plug from block. Following manufacturers instructions for tool set (J-6098) remove center bearings first.

2) Front and rear bearings are removed by assembling drive handle to tool set (J-6098) and driving bearings towards center of block.

Installation — 1) Install front and rear bearings first to act as guide for pilot of tool (J-6098) and to center remaining bearings being pulled into place.

NOTE — Oil holes in cam bearings must be aligned with oil holes in cam bore.

2) Install new camshaft rear plug flush to $\frac{1}{32}$ " (.80mm) deep and parallel with rear surface of engine block.

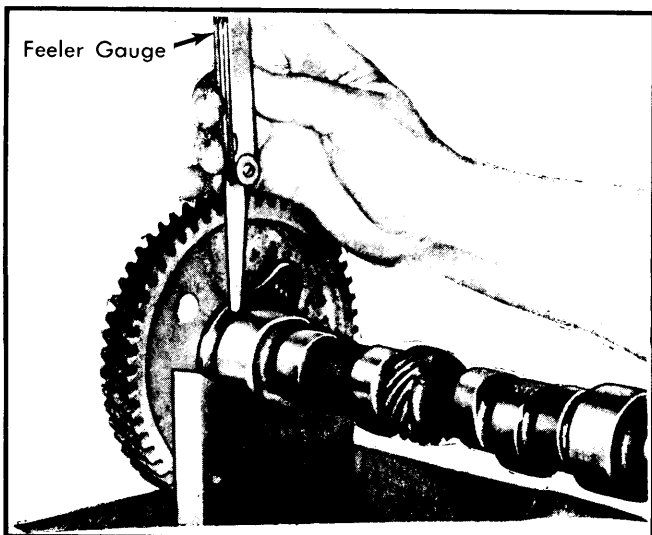

Fig. 13 Checking Camshaft End Play

CAMSHAFT END THRUST

Check camshaft end play with feeler gauge, if end play exceeds .005", gear, thrust plate or both must be replaced. See Fig. 13.

CAM LOBE LIFT

With valve cover removed, remove rocker arm. Mount dial indicator on rocker arm stud and position dial indicator stem on push rod using a suitable ball adapter (J-8520). Rotate engine slowly in direction of rotation until lifter is on heel of camshaft and set dial indicator to zero. Rotate engine until push rod is fully raised. This is camshaft lobe lift. Continue to rotate engine until indicator reads zero. This will check accuracy of original reading.

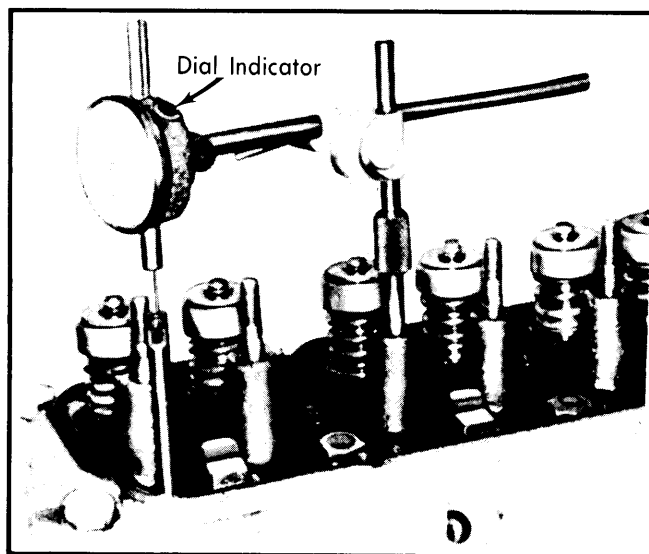

Fig. 14 Checking Camshaft Lobe Lift

ENGINE OILING

Crankcase Capacity — 250" engines 4 quarts. 292" engines 5 quarts. Add 1 quart with filter change.

Oil Filter — Replaced every other oil change or more often under dusty or severe conditions.

Oil Pressure — With engine at normal operating temperature, oil pressure should be 40 psi at 2000 RPM.

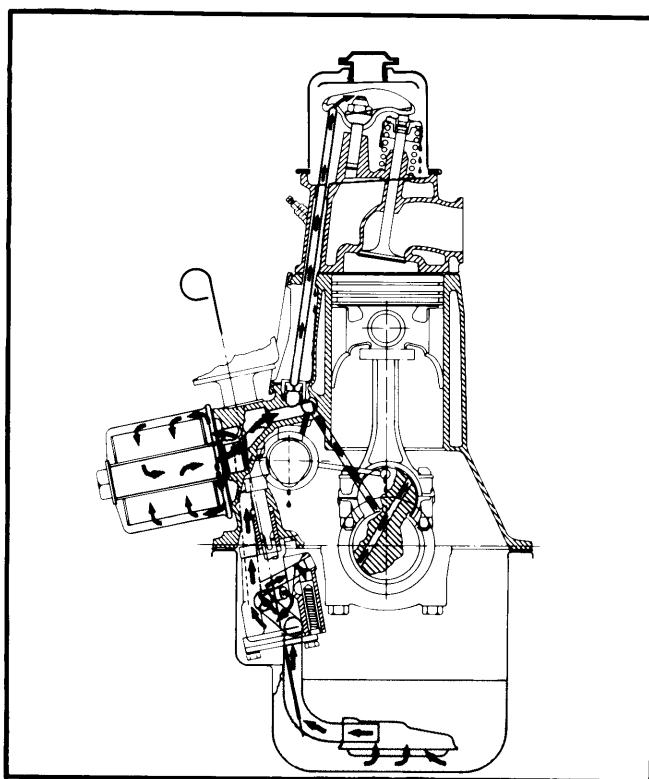

Fig. 15 Engine Oiling System

General Motors 6 Engines

250" & 292" 6 CYLINDER ENGINES (Cont.)

ENGINE OILING SYSTEM

The gear type pump provides full pressure lubrication through full flow oil filter. Oil is drawn by pick up screen, pressurized through pump and routed to oil filter. A bypass valve allows oil flow to main gallery in case backpressure is encountered at filter. This rifle drilled passage supplies oil to camshaft bearings, lifters and main bearings. Connecting rod bearings are supplied oil from crankshaft main bearings by cross drilled passages.

OIL PUMP

The valve train receives lubrication from valve lifters through hollow push rods. Oil drains back to crankcase through drain holes. Timing gears are lubricated through nozzle from front camshaft bearing. The distributor drive gear is oiled by drainage from valve lifter compartment.

Removal — Mark gears so they may be reassembled with the same teeth indexing. Do not disturb pickup screen on pipe. Screen is serviced as an assembly.

NOTE — If pump gears or body are damaged or worn, replacement of entire pump assembly is required.

Installation — Apply sealer to end of pipe and tap into place. Install idler gear in pump body with smooth side of gear toward cover opening.

NOTE — Bottom of screen must be parallel with bottom of pan.

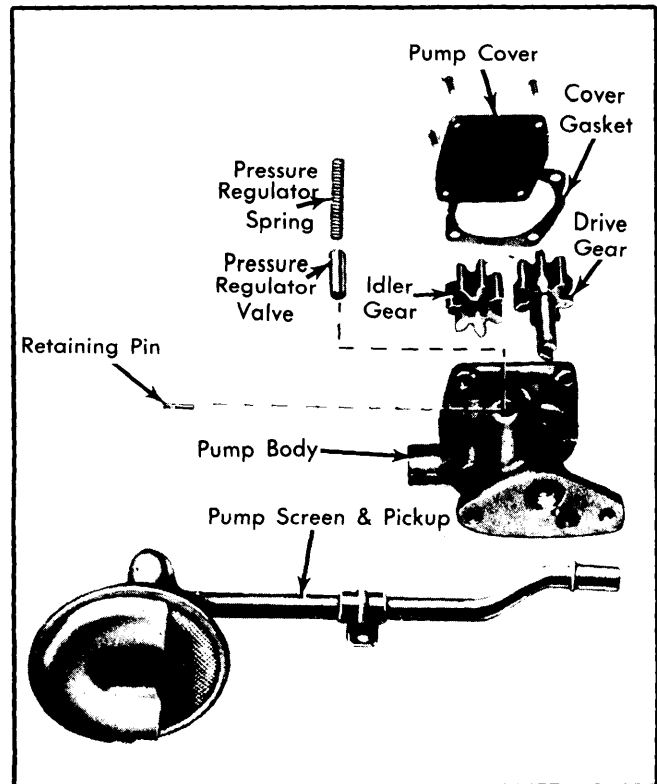

Fig. 16 Exploded View of Engine Oil Pump

ENGINE SPECIFICATIONS

GENERAL SPECIFICATIONS							
Year	Displ. Cu. Ins.	Carburetor	HP at RPM	Torque (Ft. Lbs. at RPM)	Compr. Ratio	Bore	Stroke
1980	250"	2-Bbl.	8.25:1	3.876"	3.53"
	292"	1-Bbl.	8.0:1	3.876"	4.12"

VALVES							
Engine & Valve	Head Diam.	Face Angle	Seat Angle	Seat Width	Stem Diameter	Stem Clearance	Valve Lift
250" & 292"							
	Int.	1.720"	45°	46°	.031-.063"	.3410-.3417"	.0010-.0027"
Exh.	1.500"	46°	46°	.063-.094"	.3410-.3417"	.0015-.0032"	.405"

① — 292" engine intake valve lift is .405".

General Motors 6 Engines

7-69

250" & 292" 6 CYLINDER ENGINES (Cont.)

ENGINE SPECIFICATIONS (Cont.)

PISTONS, PINS, RINGS						
Engine	PISTONS	PINS		RINGS		
	Clearance	Piston Fit	Ⓛ Rod Fit	Rings	End Gap	Side Clearance
250"	.0010-.0020"	.00015-.00025"	.0008-.0016"	1	.010-.020"	.0012-.0027"
				2	.010-.020"	.0012-.0032"
				3	.015-.055"	.000-.005"
292"	.0026-.0036"	.00015-.00025"	.0008-.0016"	1	.010-.020"	.0020-.0040"
				2	.010-.020"	.0020-.0040"
				3	.015-.055"	.005-.0055"

Ⓛ - Interference fit.

CRANKSHAFT MAIN & CONNECTING ROD BEARINGS							
Engine	MAIN BEARINGS				CONNECTING ROD BEARINGS		
	Journal Diam.	Clearance	Thrust Bearing	Crankshaft End Play	Journal Diam.	Clearance	Side Play
250"	2.2979-2.2994"	Ⓛ.0010-.0024"	No.7	.002-.006"	1.999-2.000"	.0010-.0026"	.006-.017"
292"	2.2979-2.2994"	Ⓛ.0010-.0024"	No.7	.002-.006"	2.099-2.100"	.0010-.0026"	.006-.017"

Ⓛ - Journals 1-6. No. 7 Journal is .0016-.0035".

VALVE SPRINGS			
Engine	Free Length	PRESSURE (LBS.)	
		Valve Closed	Valve Open
250"	1.88"	56-64@1.66"	166-178@1.26"
292"	1.90"	78-86@1.66"	170-180@1.26"

CAMSHAFT			
Engine	Journal Diam.	Clearance Ⓛ	Lobe Lift
250"	1.8677-1.8697"	.0015-.0035"	Ⓜ.2217"
292"	1.8677-1.8697"	.0015-.0035"	.2315"

Ⓛ - Camshaft end play is .00"

Ⓜ - Exhaust lobe lift is .231

TIGHTENING SPECIFICATIONS	
Application	Ft. Lbs.
Cylinder Head Bolts	95
Intake Manifold-to-Head (292")	40
Exhaust Manifold Bolts	Ⓛ30
Main Bearing Cap Bolts	65
Connecting Rod Cap Nuts	
250"	35
292"	40
Camshaft Thrust Plate Screws	6.6
Flywheel Bolts	
250"	60
292"	110
Oil Pump	9.6
Harmonic Balancer Bolt (292")	60
Rocker Arm Cover	4.0
Push Rod Cover	4.0

Ⓛ - Non-integral head.