

351" M & 400" V8 ENGINES

IDENTIFICATION CODING

ENGINE IDENTIFICATION

Rating plate carries information concerning vehicle model, series, point of manufacture, and unit number. Plate is located on cowl surface under hood. Number code is as follows:

U15GDC50000

- First Digit** – Truck Series Letter.
- Second & Third Digits** – Truck Series Number.
- Fourth Digit** – Engine Code.
- Fifth Digit** – Assembly Plant.
- Remaining Digits** – Consecutive Unit Number.

Engine Identification Codes

Engine	Code Letter
351" M (5.8L) 2-Bbl.	G
400" (6.6L) 2-Bbl.	Z

ENGINE REMOVAL

See *Engine Removal at end of ENGINE Section.*

CYLINDER HEAD & MANIFOLD

INTAKE MANIFOLD

Removal – 1) Remove air cleaner and air inlet duct. If equipped with air conditioning, isolate and remove compressor. Disconnect all electrical connections on manifold and position harness out of way.

2) Disconnect spark plug wires from spark plugs. Disconnect wires from valve cover brackets. Remove distributor cap and wires as a unit. Disconnect fuel inlet line at carburetor.

3) Remove heater hoses from retainers and position out of way. Remove coil, vacuum solenoid valve and bracket. Disconnect PCV hose from valve cover. Disconnect vacuum hose at distributor. Remove hold down clamp and remove distributor. Place a clean shop towel over hole.

4) Disconnect accelerator linkage, speed control cable and transmission downshift linkage (if equipped) at carburetor. Remove carburetor, manifold bolts and manifold. Remove and discard intake manifold gasket.

Installation – 1) Clean all gasket surfaces thoroughly. Apply a $\frac{1}{8}$ " bead of RTV silicone sealer to the four points at corner of heads that contact seal mounting surface of block.

2) Install a new seal on block and press locating extensions into holes in mating surface. Apply a $\frac{1}{16}$ " bead of silicone sealer to end of each seal. Place manifold gasket in position, making sure all alignment notches are under dowels on cylinder head. Make sure holes in gasket are aligned with holes in head.

CAUTION – Do Not apply sealer to waffle section of end seals as sealer will rupture the end seals.

3) Place manifold in position on engine. Tighten bolts to specification in two steps. Tighten bolts in sequence shown in illustration (see Fig. 1). After completion of intake manifold installation, retighten manifold to specification in sequence shown in illustration, with engine at normal operating temperature.

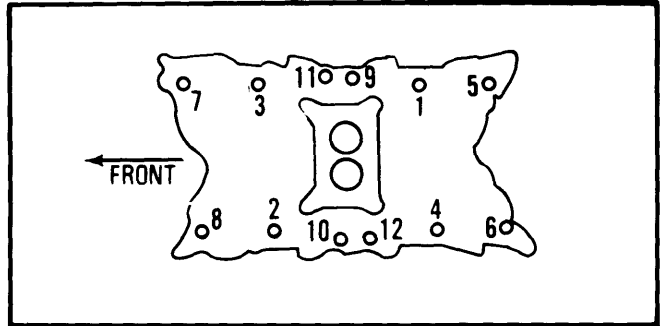

Fig. 1 Intake Manifold Tightening Sequence

CYLINDER HEAD

Removal – 1) Remove intake manifold as previously outlined. Remove valve covers. If left cylinder head is being removed on a vehicle equipped with air conditioning, isolate and remove compressor.

2) If left cylinder head is being removed on a vehicle with power steering, disconnect pump bracket from cylinder head. Remove pump drive belt. Place pump out of way, sitting up straight to prevent fluid loss.

3) If right cylinder head is being removed, remove alternator mounting bracket through bolt and air inlet duct. Disconnect ground wire from rear of head. Disconnect exhaust pipes at manifolds.

4) Remove rocker arm bolts, oil deflectors, fulcrum seats, rocker arms and push rods in sequence. Same components must be installed in original position. Remove cylinder head bolts and remove cylinder head.

Installation – 1) Clean all gasket surfaces. Check cylinder head and block for flatness if cylinder head was removed for gasket replacement. Place a new gasket over dowel pins on block.

NOTE – A specially treated composition gasket is used and does not require sealer.

2) Install cylinder heads and bolts. Tighten head bolts in two steps. See *Tightening Specifications*. Tighten bolts in sequence shown in illustration (see Fig. 2). Reverse removal procedure to complete installation.

NOTE – On E-150-350 it may be necessary to remove left-hand cylinder head with forward bolt due to closeness of body flange.

351" M & 400" V8 ENGINES (Cont.)

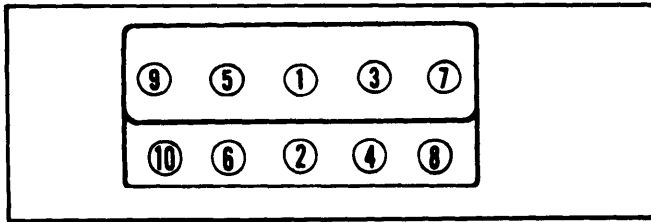

Fig. 2 Cylinder Head Tightening Sequence

VALVES

VALVE ARRANGEMENT

E-I-E-I-E-I-E-I (left bank, front to rear.)
I-E-I-E-I-E-I-E (right bank, front to rear.)

VALVE GUIDE SERVICING

To ream guides for installation of valves with oversize stems, always use reamers in size sequence and reface valves and valve seats after guide is reamed. Reamers are furnished .003" oversize with standard diameter pilot; .015" oversize reamer with .003" oversize pilot; and .030" oversize reamer with .015" oversize pilot.

NOTE — Use suitable scraper tool to break sharp corner (ID) at top of valve guide after reaming.

VALVE STEM OIL SEALS

Cup or umbrella type oil seals are used on valves. Lubricate valve stem with engine oil and install seal with cup side down over valve guide using $\frac{5}{8}$ " deep well socket and light mallet to seat seal on valve stem.

VALVE SPRINGS

Removal — 1) Remove air cleaner. Remove valve cover and spark plug for cylinder being serviced. Install an air line with adapter in spark plug hole.

NOTE — If air pressure fails to hold valve closed, remove cylinder head for inspection of valve seat.

2) Remove required rocker arm and push rod. Using a suitable spring compression tool, compress valve spring and remove spring retainer locks. Release spring compressor. Remove retainer and valve spring. Remove valve stem seal.

CAUTION — Do not release air pressure as this will allow valve to fall into cylinder if piston is at bottom of stroke.

Installation — 1) With valve stem seal installed, place spring in position over valve. Install spring retainer. Compress spring with spring compressor and install retainer locks.

2) Apply Lubriplate (or equivalent) to end of push rods and tip of valve stem. Install rocker arm and tighten fulcrum bolt to specification. Install valve cover.

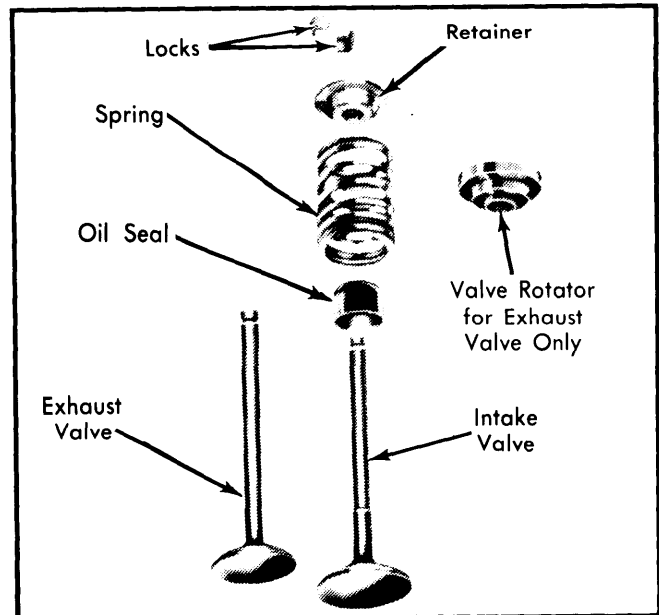

Fig. 3 Exploded View of Valve Assemblies

VALVE SPRING INSTALLED HEIGHT

Valve spring ends must be square within $\frac{5}{4}$ " tolerance. Installed height of valve spring must not exceed specifications. Measure spring height from surface of cylinder head pad to underside of spring retainer. If height is greater than specified, install a .030" spacer on head under spring to bring height within limits.

CAUTION — Install spacer only if necessary and do not use more than two spacers as any more will overstress springs and overload camshaft lobes.

Valve Spring Installed Height Specifications

Application	Installed Height
351" M & 400"	
Int.	$1\frac{3}{16}$ " - $1\frac{27}{32}$ "
Exh.	$1\frac{11}{16}$ " - $1\frac{23}{32}$ "

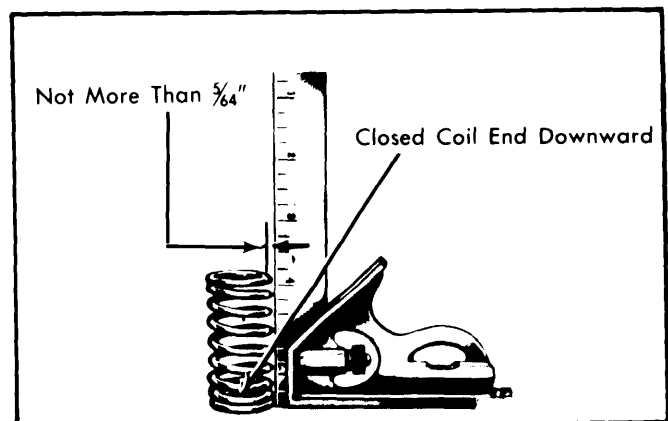

Fig. 4 Checking Valve Spring Squareness

351" M & 400" V8 ENGINES (Cont.)

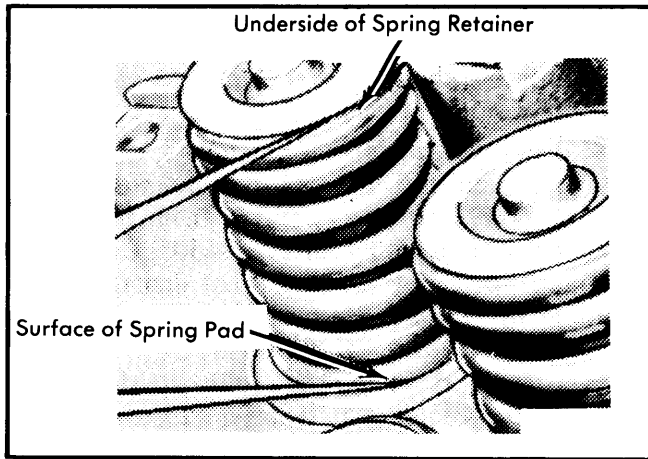

Fig. 5 Checking Installed Height of Valve Spring

ROCKER ARM ASSEMBLY

Inspect rocker arms, fulcrum seats and fulcrum bolts for excessive wear. Replace components as necessary.

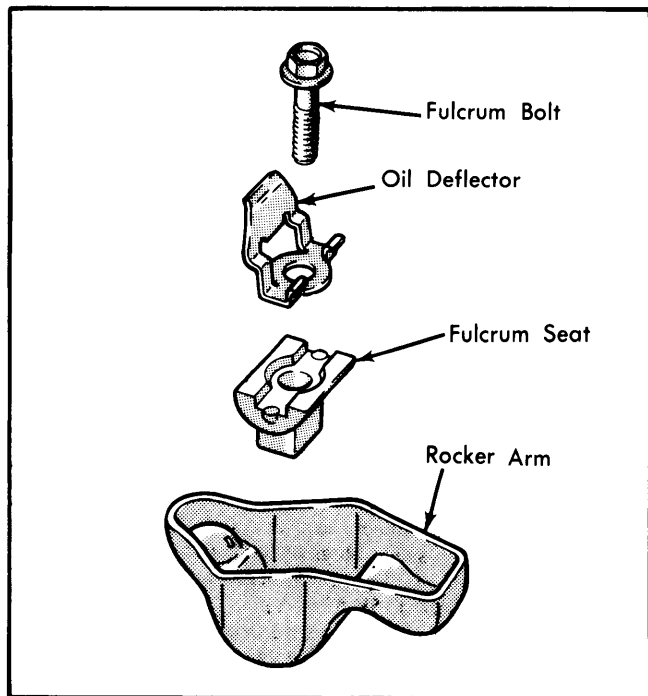

Fig. 6 Rocker Arm Assembly

HYDRAULIC VALVE LIFTER ASSEMBLY

Lifters should be serviced as assemblies only, integral components are matched sets and cannot be interchanged. Leak down rate on hydraulic lifters is 10-50 seconds at 1/16" plunger travel using a suitable leak down rate tester. Replace lifter assembly if any sign of malfunction occurs.

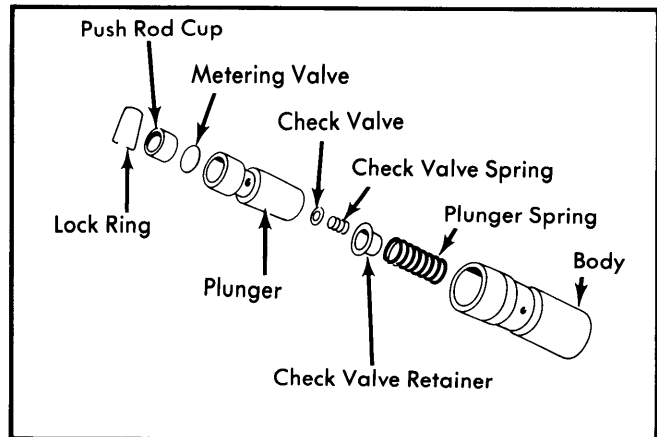

Fig. 7 Disassembled View of Hydraulic Valve Lifter

HYDRAULIC VALVE LIFTER ADJUSTMENT

Repeated valve (seat and face) reconditioning operations will decrease valve stem to rocker arm clearance to a point that if compensation is not made, valve lifters will cease to function. To compensate for any dimensional changes in valve mechanism, a shorter or longer replacement push rod is available.

1) To determine whether or not a longer or shorter push rod is necessary, clearance between rocker arm and valve stem must be checked.

NOTE — Valve lifter must be completely collapsed when checking valve clearance.

2) Use a suitable tool to slowly collapse lifter until plunger is bottomed. Hold lifter down while checking clearance.

3) Rotate crankshaft until No. 1 piston is at TDC (point 1, see Fig. 8) after compression stroke as indicated by timing mark on crankshaft damper and pointer. Make chalk mark on damper 180° (point 2) from TDC mark. Make a chalk mark 90° (point 3) clockwise from TDC mark.

4) With damper at point 1, check clearance on intake valves 1, 4 and 8 and exhaust valves 1, 3 and 7.

5) Rotate crankshaft 180° clockwise from point 1 so that point 2 is opposite pointer. Check clearance on intake valves 3 and 7 and exhaust valves 2 and 6.

6) Rotate crankshaft 270° clockwise from point 2 so point 3 is opposite pointer. Check clearance on intake valves 2, 5 and 6 and exhaust valves 4, 5 and 8.

Collapsed Lifter Clearance

Application	Desired	Allowable
351" M & 400"125-.175"	.100-.200"

351" M & 400" V8 ENGINES (Cont.)

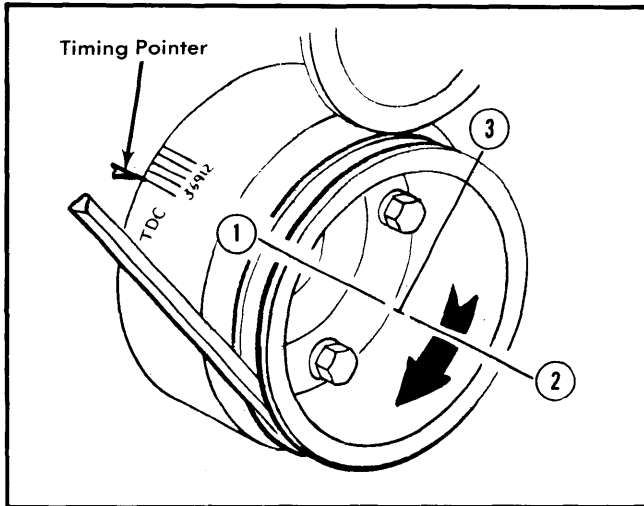

Fig. 8 Crankshaft Positions for Adjusting Hydraulic Valve Lifters

PISTON, PINS & RINGS

OIL PAN

See Oil Pan Removal at end of ENGINE Section.

PISTON & ROD ASSEMBLY

NOTE — New pistons must be installed in same cylinders for which they were fitted and used pistons in same cylinder from which they were removed.

Removal — 1) With cylinder head and oil pan removed, use a ridge reamer to remove any ridge or deposits on upper end of cylinder bore. Piston must be at bottom of stroke and covered with cloth to collect cuttings.

NOTE — Never cut more than $\frac{1}{32}$ " from ring travel area of bore when removing ridge.

2) Inspect connecting rods and caps for cylinder identification and mark as necessary. Remove rod cap and push piston and rod assembly out top of block, taking care not to nick crankshaft journal or cylinder wall.

Installation — 1) Lightly coat cylinder bores, pistons and rings with engine oil. Make sure ring gaps are properly spaced. See Fig. 10.

2) Compress piston rings with a suitable ring compressor. Install each piston and rod assembly in cylinder bore with notch on piston toward front of engine and numbered side of rod facing away from camshaft.

3) Guide connecting rod onto crankshaft journal while tapping piston head with hammer handle to seat connecting rod bearing against crankshaft. Install connecting rod cap, aligning numbers. Tighten nuts to specification.

FITTING PISTONS

Measure piston at centerline of piston pin bore 90° to pin bore axis. Measure cylinder bore at right angle to centerline of

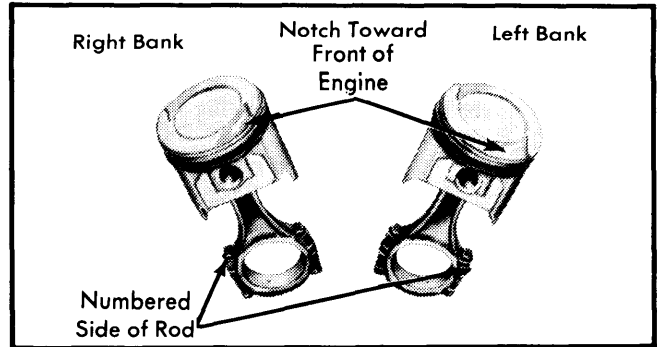

Fig. 9 Fitting Piston and Connecting Rod Assembly

crankshaft, below ring travel. Piston-to-bore clearance should be as shown in Pistons, Pins & Rings table. Check Piston Size Code Chart to determine correct size. Make sure both piston and cylinder block are at normal room temperature (70°F) when fitting.

Piston Size Code Chart

Code	Piston Size
Red	3.9982-3.9988"
Blue	3.9994-4.000"
.003" Oversize	4.0006-4.0012"

FITTING RINGS

1) Position ring in the cylinder bore that it will be used in. Push ring down to point in bore where ring wear is not encountered. Use head of piston to position ring squarely in bore.

2) Measure gap between ends of ring using a feeler gauge, if not to specification, substitute another ring set until rings are within specification.

CAUTION — Use care to avoid damage to ring or cylinder bore.

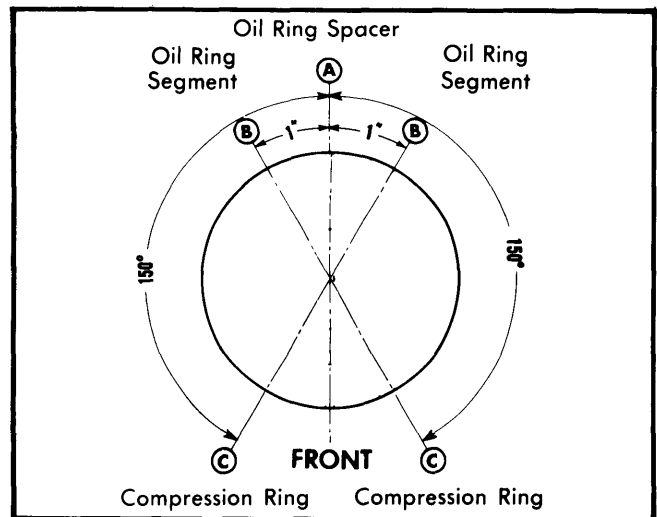

Fig. 10 Correct Spacing for Piston Ring Gaps

351" M & 400" V8 ENGINES (Cont.)

PISTON PINS

Removal — Using an arbor press and removal/installation tool T68P-6135 and adapters, press piston pin out of connecting rod and piston. See Fig. 11.

Installation — 1) Make sure piston pin and connecting rod have correct interference fit specifications. Apply a light coat of oil to piston pin and to pin bore in rod and in piston.

2) Position piston on connecting rod as shown. See Fig. 9. Use arbor press to press piston pin into connecting rod and piston. See Fig. 11.

NOTE - If rods are replaced, position piston on rod so that large chamfered side of rod bearing bore faces forward on right bank and faces rearward on left bank.

CRANKSHAFT & ROD BEARINGS

MAIN & CONNECTING ROD BEARINGS

Connecting Rod Bearings — 1) With crankshaft lined up in center of bore, push piston and connecting rod up into bore to gain clearance for upper bearing removal. Remove lower bearing half from cap.

2) After rod bearings have been fitted using Plastigage method, apply light coat of engine oil to journals and bearings. With crankshaft throw at bottom of stroke, move piston down until connecting rod bearing seats on crankshaft journal. Install connecting rod cap and nuts and tighten to specification checking connecting rod side clearance.

Main Bearings — 1) Mark main bearing caps for identification before removal from block. Remove upper half of main bearing by inserting removal tool 6331 (or equivalent), into oil hole of crankshaft and slowly rotate crankshaft in direction of engine rotation.

NOTE — Replace one bearing at a time leaving other bearings secured until ready to change.

2) — If bearing clearance is excessive, a .001" or .002" undersize bearing half may be used in combination with a standard size half. If .002" undersize bearings are used on more than one journal, they may be positioned in engine block rather than bearing cap. If standard and .002" undersize combination did not bring bearing clearance within specified limits, crankshaft will have to be refinished and suitable undersize bearings installed.

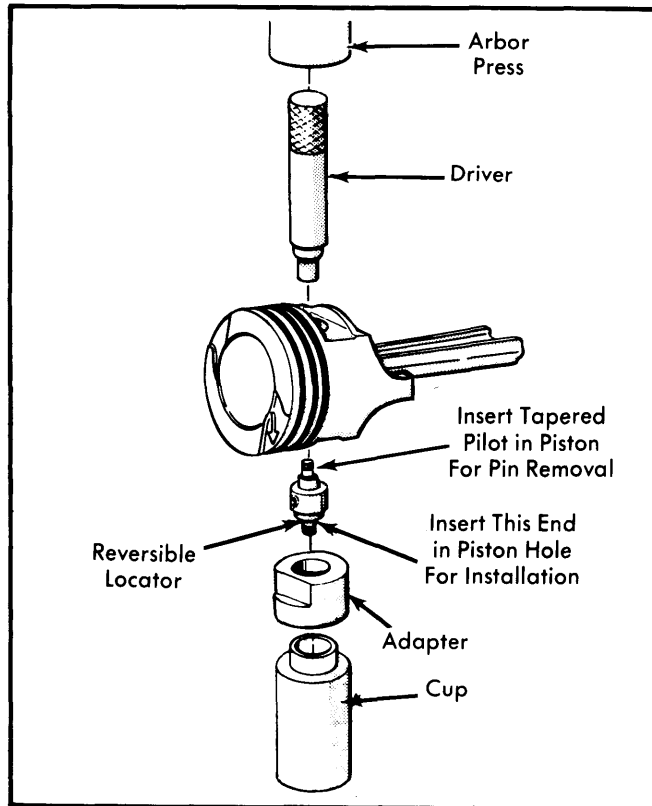

Fig. 11 Removing and Installing Piston Pins

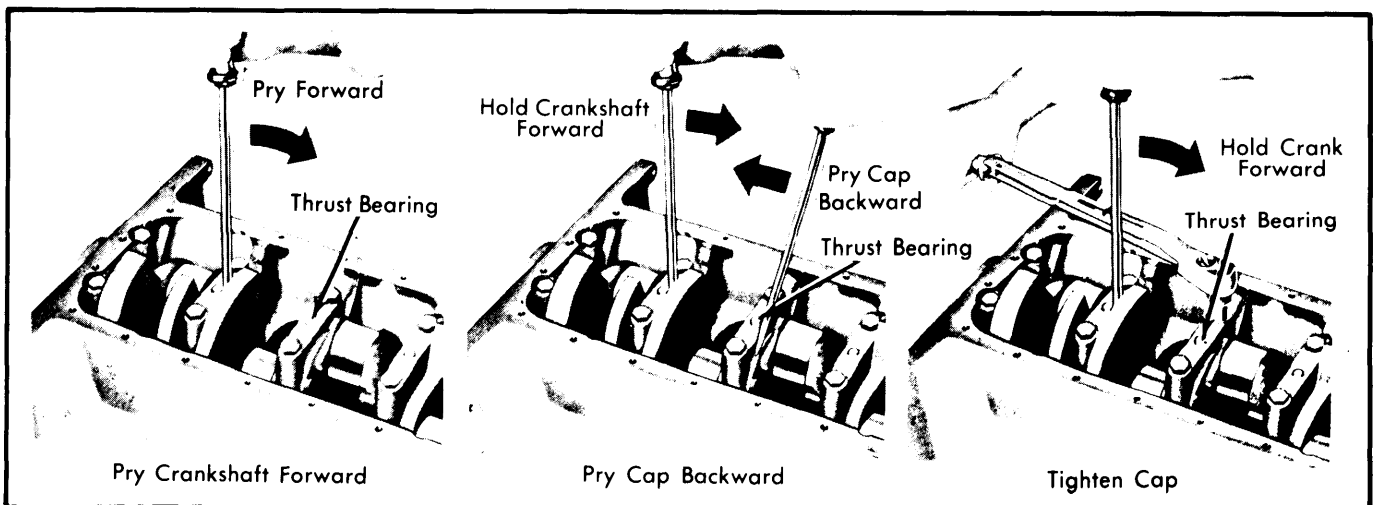

Fig. 12 Aligning Thrust Bearing

351" M & 400" V8 ENGINES (Cont.)

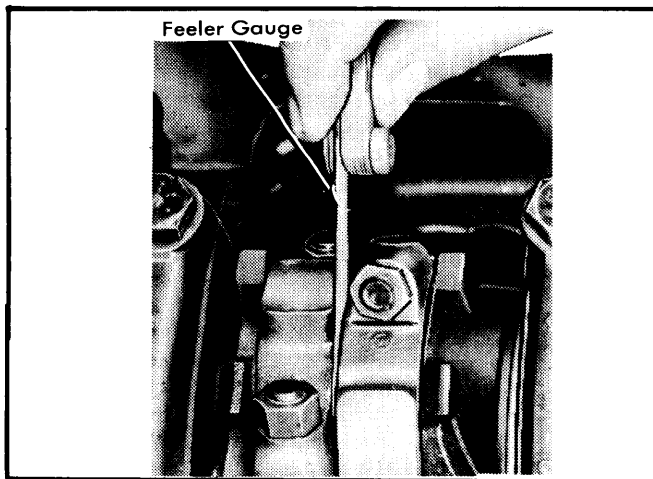

Fig. 13 Measuring Connecting Rod Side Clearance

3) To install upper main bearings, lubricate bearing with engine oil and place plain end of bearing over crankshaft on locking tang side of block. Partially insert bearing to allow suitable tool (6331-E) to be inserted into oil hole in crankshaft journal. Rotate crankshaft in opposite direction of engine rotation until bearing is seated. Remove installer tool. Install bearing cap and tighten bolts to specification.

THRUST BEARING ALIGNMENT

Install thrust bearing cap after all other main caps have been tightened. Install thrust bearing cap with bolts finger tight. Pry crankshaft forward against thrust surface of upper half of bearing. Hold crankshaft forward and pry thrust bearing cap to rear. This will align thrust surfaces of both halves of bearing. Retain forward pressure on crankshaft and tighten cap bolts to specification.

REAR MAIN BEARING OIL SEAL

Removal - 1) Complete seal can be replaced without removing crankshaft. Remove oil pan and oil pump. Loosen all main bearing cap bolts and allow crankshaft to drop slightly, but not to exceed $\frac{1}{32}$ ".

2) Remove rear main bearing cap and remove oil seal from bearing cap and block. On block half of seal, use seal removing tool or place small metal screw in one end of seal and pull on screw to remove seal. Care must be taken to prevent scratching or damage to crankshaft seal surface.

3) Remove oil seal retaining pin from bearing cap (if equipped). Replacement seal does not use pin. Discard pin after removal.

Installation - 1) Clean oil seal groove. Dip new seal halves in engine oil. Carefully install block upper seal half into groove. Make sure undercut (lip) side of seal is toward front of engine. Install by rotating seal on journal of crankshaft until approximately $\frac{3}{8}$ " of seal protrudes from parting surface.

CAUTION - Avoid shaving any rubber from outside diameter of seal by bottom edge of groove. Do not allow oil to get into sealing area.

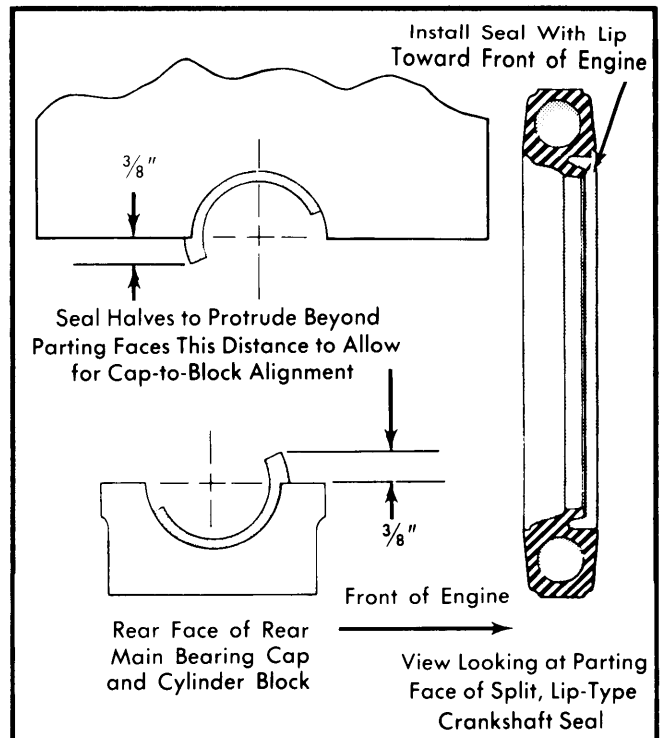

Fig. 14 Installing Crankshaft Rear Oil Seal

2) Tighten remaining bearing cap bolts to specification. Install lower seal in cap with undercut side of seal toward front of engine. Allow seal to protrude $\frac{3}{8}$ " above parting surface to mate with upper seal when cap is installed.

3) Apply suitable RTV silicone sealer to areas shown in illustration (Fig. 15). Install bearing cap. Tighten bolts to specification.

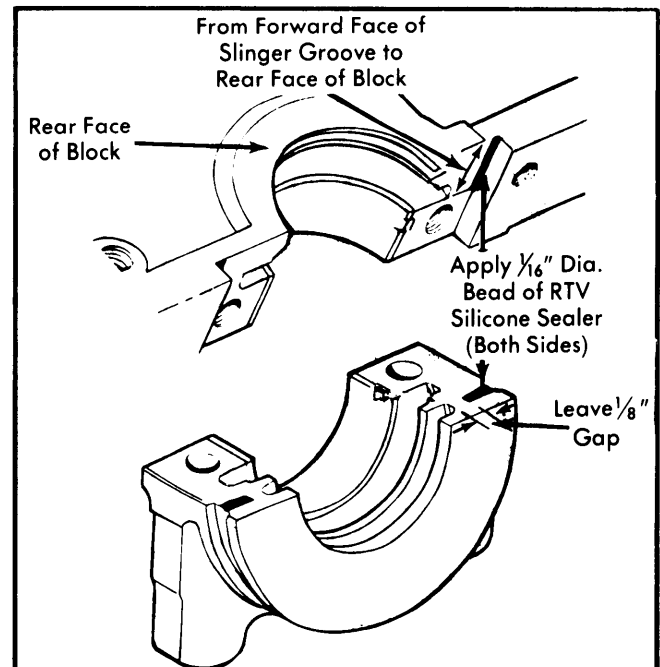

Fig. 15 Applying Sealer to Main Bearing Cap and Block

351" M & 400" V8 ENGINES (Cont.)

CAMSHAFT

ENGINE FRONT COVER

Removal – 1) Drain cooling system and disconnect battery. Remove fan shroud attaching bolts and move shroud to rear. Remove fan and spacer from water pump. If equipped with air conditioning, remove belt, lower idler pulley and compressor to water pump mount.

2) Remove alternator drive belt and power steering drive belt. Remove water pump pulley. Remove alternator bracket from water pump and position out of way. Remove power steering pump bracket and position out of way. Disconnect heater hose and lower radiator hose from water pump.

3) Remove crankshaft pulley from damper. Remove damper screw and pull off damper with a puller. Remove timing pointer. Remove bolts securing front cover and water pump to cylinder block and remove front cover (with water pump attached).

Installation – Clean all gasket surfaces. Use suitable sealer and install gaskets. Coat threads of bolts with sealer. Apply Lubriplate to oil seal running surface on damper. Tighten screws to specification. Oil pan must be removed and a new front seal installed when cover is removed. Reverse removal procedure to complete installation.

FRONT COVER OIL SEAL

Removal – 1) Remove fan shroud bolts and slide back over engine. Remove water pump belt. Remove fan, spacer and shroud. Remove remaining drive belts. Remove crankshaft pulley from vibration damper.

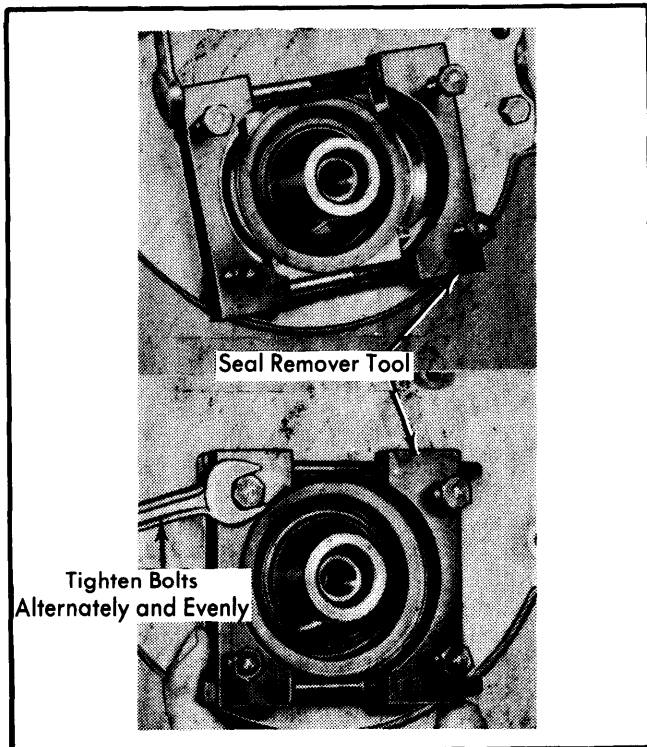

Fig. 16 Removing Front Cover Oil Seal

2) Remove vibration damper bolt. Pull off damper with a suitable puller. Attach a suitable seal remover tool (T70P-6B070-B) to lip of front seal. Tighten puller bolts and remove seal (see Fig. 16).

Installation – Coat a new front cover oil seal with Lubriplate. Position seal on crankshaft against seal bore in front cover. Position a suitable seal installation sleeve (T70P-6B070-A) on crankshaft. Tighten tool bolt into crankshaft and turn tool nut against screw to push seal into place. Reverse removal procedure to complete installation.

TIMING CHAIN

Removal – Remove front engine cover as previously outlined. Remove fuel pump outlet line and mounting bolts. Lay fuel pump to side. Crank engine over until timing marks are aligned as shown in illustration (see Fig. 17). Remove camshaft sprocket bolt. Remove washer and two piece fuel pump eccentric. Slide both sprockets and timing chain forward to remove.

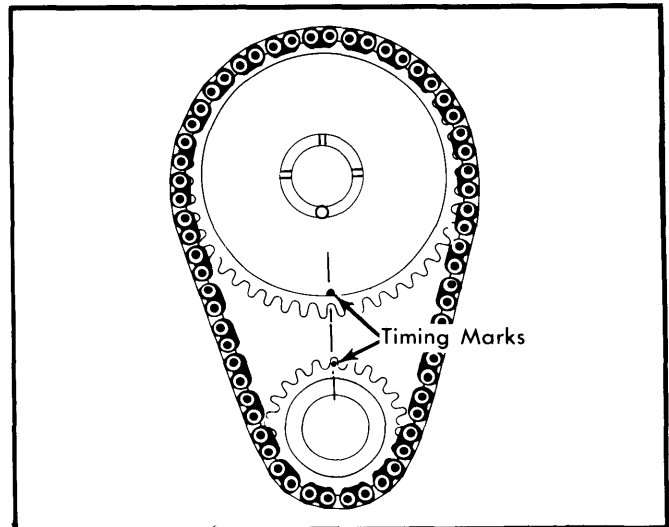

Fig. 17 Aligning Timing Sprocket Marks

Installation – 1) Position timing chain on sprockets, aligning timing marks as shown in illustration (See Fig. 17). Slide timing chain and sprockets onto camshaft and crankshaft as an assembly.

2) Install 2-piece fuel pump eccentric, washers and camshaft sprocket bolt. Tighten bolt to specifications. Reverse removal procedure to complete installation.

CAMSHAFT

Removal – 1) Drain cooling system. Disconnect upper and lower radiator hoses at radiator. Disconnect oil cooler lines at radiator (if equipped). Remove air conditioning condenser (if equipped) after discharging system. Remove front engine cover and timing chain as previously outlined.

2) Remove intake manifold as previously outlined. Remove valve covers. Loosen but do not remove rocker arm fulcrum bolts. Rotate rocker arms to side and remove push rods. Mark or identify push rods to ensure that they are installed in original position. Remove valve lifters. Mark or identify lifters to ensure that they are installed in original position.

351" M & 400" V8 ENGINES (Cont.)

3) Turn engine over until number one piston is at TDC. Remove camshaft thrust plate bolts and remove thrust plate. Carefully pull camshaft toward front to remove. Care must be taken when withdrawing camshaft to avoid damaging camshaft bearings or camshaft lobes.

Installation — Coat camshaft lobes with Lubriplate and bearing journals with heavy engine oil. Carefully install camshaft in engine. Install thrust plate and tighten bolts. Install timing chain as previously outlined. To complete installation, reverse removal procedure.

CAMSHAFT BEARINGS

NOTE — Engine must be removed from vehicle and flywheel, crankshaft, and camshaft must be removed. Bearings are not interchangeable from one bore to another.

Removal — Drive out camshaft rear plug and all camshaft bearings using a suitable driver and mandrels of correct size.

Installation — Drive new bearing into position, making sure oil holes are aligned. Make sure front bearing is installed .040-.060" below front edge of cylinder block. Install camshaft rear plug.

CAMSHAFT END THRUST

Rocker arm fulcrum bolts must be loosened to free load on camshaft. Push camshaft toward rear of engine. Install a dial indicator so that plunger is on camshaft sprocket bolt. Zero dial indicator. Position a screwdriver between camshaft sprocket and cylinder block. Pry camshaft forward and release. If end play exceeds .009", replace thrust plate.

CAMSHAFT LOBE LIFT

Check lift of each camshaft lobe in consecutive order as follows:

1) Remove all rocker arms. Mark or identify rocker arms to ensure that they are installed in original position. Make sure each push rod is in valve lifter socket. Install a dial indicator allowing ball socket adapter of dial indicator to rest on end of push rod in same plane as push rod movement.

2) Using a remote starter (with ignition switch in "OFF" position), turn engine until valve lifter being checked is on base circle of camshaft lobe, indicating lowest point of push rod travel.

3) Zero dial indicator and continue to rotate engine until push rod is in fully raised position giving highest indicator reading. Continue same procedure for each camshaft lobe. Compare camshaft lift from dial indicator readings with specifications.

4) To check accuracy of dial indicator readings, continue to rotate engine until dial indicator reads zero. If lift on any camshaft lobe is .005" less than specifications, camshaft lobes are worn. Camshaft and lifter must be replaced.

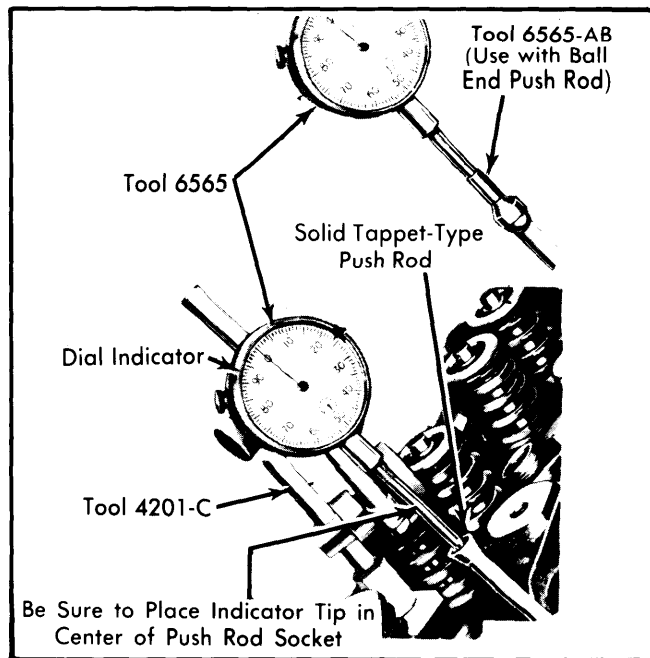

Fig. 18 Checking Camshaft Lobe Lift

ENGINE OILING

Crankcase Capacity — 5 quarts. Add 1 quart with filter change.

Oil Filter — Replace at first oil change and every second oil change after that.

Normal Oil Pressure — Oil pressure should be 50-75 psi at 2000 RPM.

Pressure Regulator Valve — In oil pump body on all engines. Not adjustable.

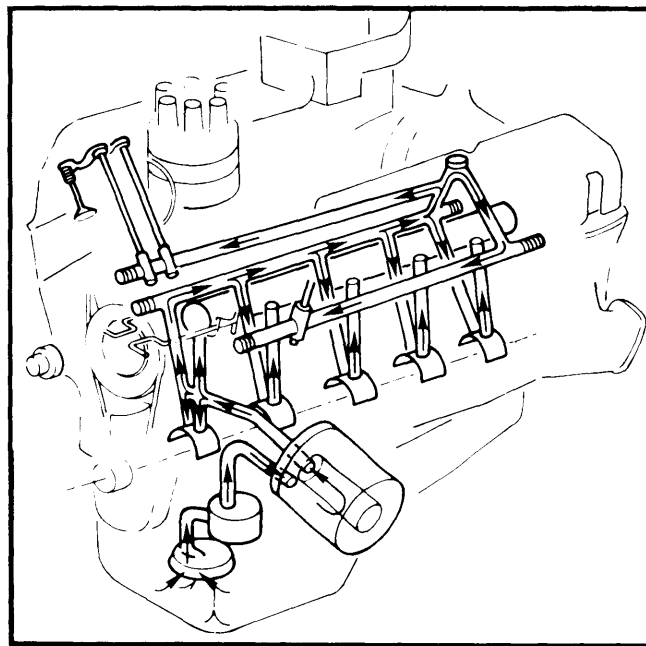

Fig. 19 Engine Oiling System

351" M & 400" V8 ENGINES (Cont.)

ENGINE OILING SYSTEM

System is pressure fed from rotor type oil pump in left forward section of engine. Oil flows through full-flow oil filter before entering main oil gallery on right side of camshaft. Oil from main oil gallery enters main bearings through drilled passages in block, passes through main bearings up to camshaft bearings. Oil moves through secondary drilled passages from main bearings to lifter galleries. Push rods pick up oil from lifters and through rotation of push rods, moves oil up to top of head assembly to rocker arms. Oil is returned to oil pan through drain holes in head assemblies back down into crankcase.

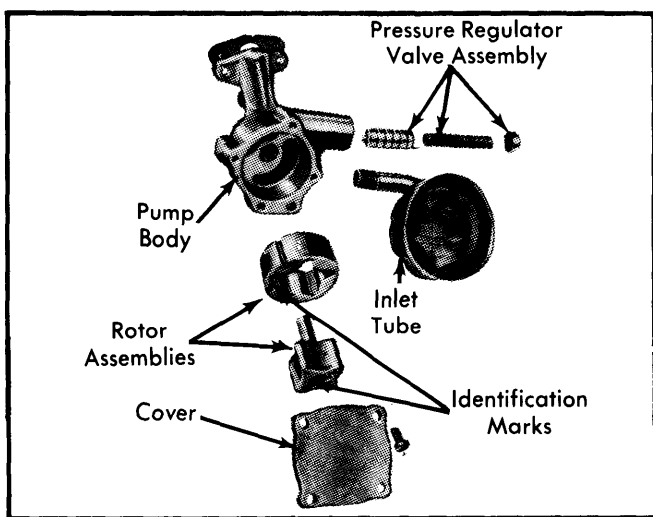

Fig. 20 Exploded View of Oil Pump

OIL PUMP

Removal & Disassembly — With oil pan removed, remove pump bolts and remove pump. Remove oil inlet tube from pump. Remove cover screws and cover. Remove inner rotor and shaft assembly, then remove outer rotor. Remove cotter pin from pump housing. Drill a small hole in pressure regulator valve plug. Screw in a self threading sheet metal screw then pull plug out of bore. Remove spring and plunger.

Inspection & Reassembly — Clean, inspect and oil all components thoroughly. Install pressure regulator valve plunger, spring and a new cap. Stake cap into position. Install inner and outer rotor. Make sure identification marks on inner and outer rotor are facing outward and to same side. Check various oil pump clearances as outlined in specifications. Install cover and tighten bolts. Install oil inlet tube using new gasket. Submerge inlet tube in oil and prime pump by rotating shaft until oil emerges from outer port.

Oil Pump Specifications	
Application	Specifications
Pressure Regulator Valve	
Spring Tension	20.6-22.6@2.49"
Shaft-to-Housing Clearance0015-.0030"
Pressure Regulator Valve Clearance0015-.0030"
Rotor Assembly End Clearance004" Max.
Outer Rotor-to-Housing Clearance001-.003"

ENGINE SPECIFICATIONS

GENERAL SPECIFICATIONS							
Year	Displ. Cu. Ins.	Carburetor	HP at RPM	Torque (Ft. Lbs. at RPM)	Compr. Ratio	Bore	Stroke
1980	351" M	2-Bbl.	4.00"	3.50"
	400"	2-Bbl.	4.00"	4.00"

VALVES								
Engine & Valve	Head Diam.	Face Angle	Seat Angle	Seat Width	Stem Diameter	Stem Clearance	Valve Lift	
351" M	Int.	2.032-2.050"	44°	45°	.060-.080"	.3416-.3423"	.0010-.0027"	.4325"
	Exh.	1.6495-1.6595"	44°	45°	.070-.090"	.3411-.3418"	.0015-.0032"	.4325"
400"	Int.	2.032-2.050"	44°	45°	.060-.080"	.3416-.3423"	.0010-.0027"	.4325"
	Exh.	1.6495-1.6595"	44°	45°	.070-.090"	.3411-.3418"	.0015-.0032"	.4325"

Ford Motor Co. V8 Engines

351" M & 400" V8 ENGINES (Cont.)

ENGINE SPECIFICATIONS (Cont.)

CRANKSHAFT MAIN & CONNECTING ROD BEARINGS							
Engine	MAIN BEARINGS				CONNECTING ROD BEARINGS		
	Journal Diam.	Clearance	Thrust Bearing	Crankshaft End Play	Journal Diam.	Clearance	Side Play
351" M & 400"	2.9994-3.0002"	①.0008-.0015"	No.3	.004-.008"	2.3103-2.3111"	②.0008-.0015"	.010-.020"

① - Allowable clearance is .0008-.0026"

② - Allowable clearance is .0008-.0025"

PISTONS, PINS, RINGS						
Engine	PISTONS	PINS		RINGS		
	Clearance	Piston Fit	Rod Fit	Rings	End Gap	Side Clearance
351" M & 400"	.0014-.0022"	.0003-.0005"	Interference Fit	1	.010-.020"	.0019-.0036"
				2	.010-.020"	.002-.004"
				3	.010-.035"	Snug

VALVE SPRINGS			
Engine	Free Length	PRESSURE (LBS.)	
		Valve Closed	Valve Open
351" M & 400"	2.06"	76-84@1.82"	215-237@1.39"
	1.93"	79-87@1.68"	215-237@1.39"

CAMSHAFT			
Engine	Journal Diam.	Clearance	Lobe Lift
351" M & 400"		①	
No. 1	2.1238-2.1248"	.001-.003"	.250"
No. 2	2.0655-2.0665"		
No. 3	2.0505-2.0515"		
No. 4	2.0355-2.0365"		
No. 5	2.0205-2.0215"		

① - Camshaft end play is .001-.006"

TIGHTENING SPECIFICATIONS	
Application	Ft. Lbs.
Cylinder Head	
Step One	75
Step Two	95-105
Oil Pan	
1/4" Bolts	7-9
5/16" Bolts	11-13
Intake Manifold	
5/16" Bolts	19-35
3/8" Bolts	22-32
Exhaust Manifold	18-24
Flywheel-to-Crankshaft	75-85
Main Bearing Caps	95-105
Connecting Rod Caps	40-45
Pulley-to-Damper	35-50
Damper-to-Crankshaft	70-90
Camshaft Thrust Plate	9-12
Camshaft Sprocket Bolt	40-45
Rocker Arm Fulcrum Bolt	18-25
Rocker Arm Cover Bolts	3-5
Oil Filter Insert-to-Block	20-30
Oil Pump-to-Cylinder Block	22-32