

# Propeller Shafts

## UNIVERSAL JOINTS

### MAINTENANCE

If slip yoke has a tendency to stick in extension housing seal, service as follows:

Remove propeller shaft from vehicle and clean yoke with suitable solvent. Lubricate inside diameter of seal with synthetic oil seal lubricant and outside diameter of seal with transmission fluid.

**NOTE** — This procedure should also be followed whenever shaft is removed from vehicle.

### OVERHAUL

#### ALL MODELS

**NOTE** — Universal joints should not be disassembled or lubricated unless external leaking or damage has occurred.

Before disassembly, scribe alignment marks on yoke and shaft to allow reassembly in original position. If joints are rusted or corroded, apply penetrating oil before pressing out bearing cups or trunnion pin.

#### CROSS & ROLLER TYPE

Two different retaining methods are used for bearing cups, snap ring or nylon retainers. Joints with snap rings may be taken apart and reassembled using same cross and bearings. Joints with nylon retainers are disassembled by braking nylon retainers (therefore, they must be replaced after service).

**Disassembly** — 1) Disconnect yoke attaching bolts or flange attaching bolts and remove propeller shaft from vehicle.

**NOTE** — Do not use pry bar to hold propeller shaft while loosening bolts as damage to bearing seals may result.

- 2) Remove retaining strap (if equipped), remove bushing retainers from yoke, and press out rollers and bushings. Remove last roller and bushing assembly by pressing on end of cross.
- 3) Remove cross assembly from yoke. Do not remove seal retainers from cross. Cross and retainers are serviced as an assembly.

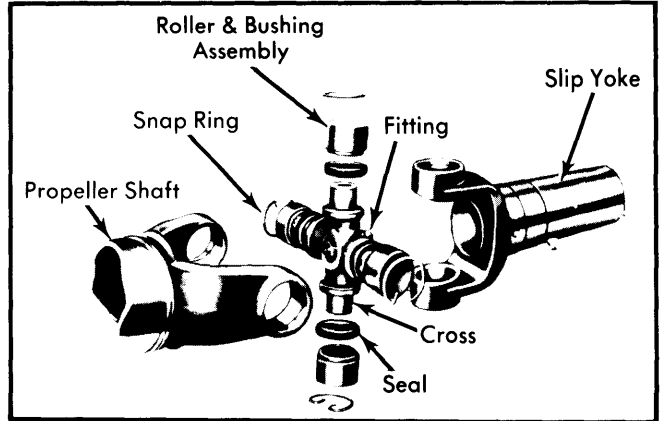
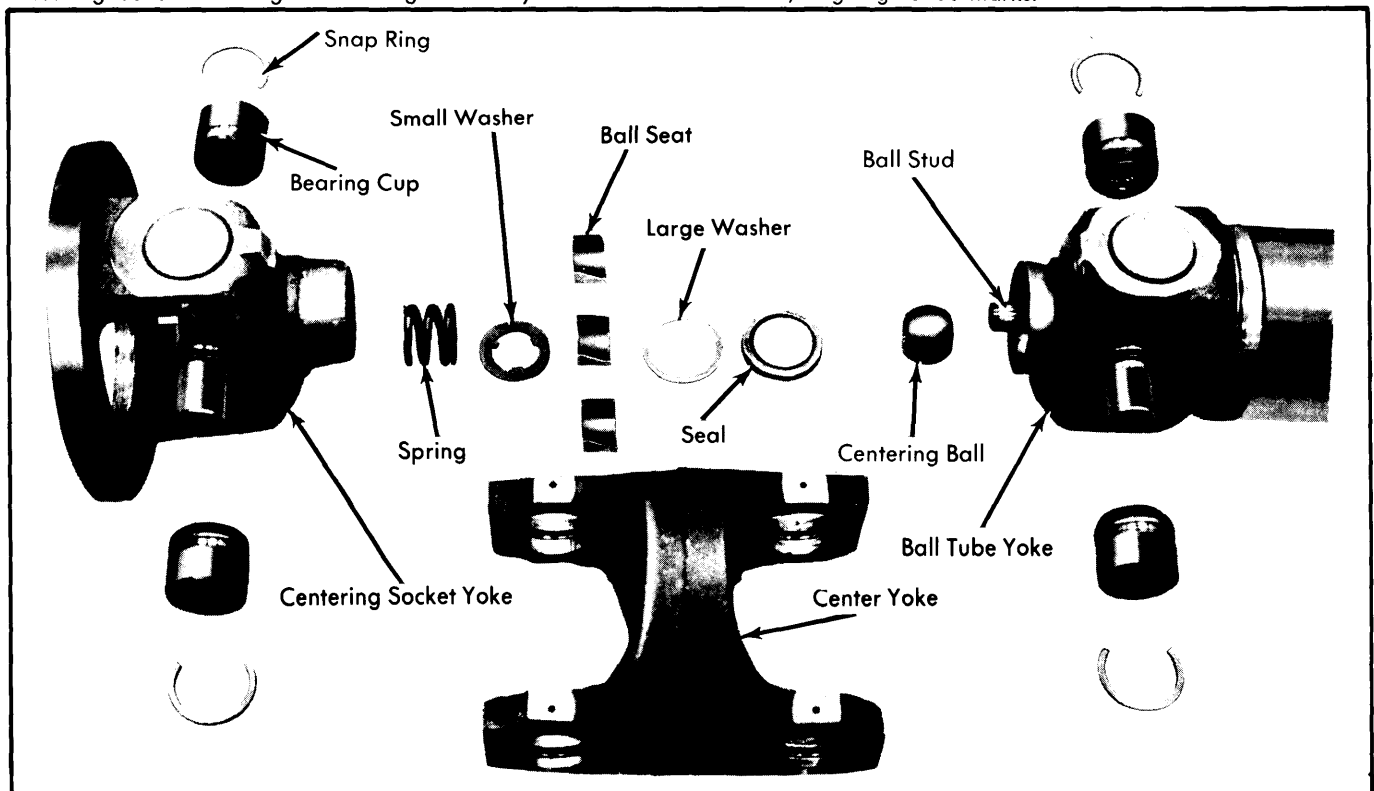

**Fig. 2 Exploded View of General Motors Universal Joint**

**Reassembly** — 1) Coat roller and bearing assemblies with suitable lubricant and fill reservoirs in ends of cross. Place cross assembly in propeller shaft yoke and place roller and bushing assemblies into position.

2) Press both bushing assemblies into yoke until retainers can be installed. Being careful to keep cross aligned in center of bushings.

3) Install retainers, then repeat procedure for remaining bushings. Install strap (if equipped). Install propeller shaft in vehicle, aligning scribe marks.



**Fig. 1 Exploded View of General Motors and Jeep Constant Velocity Type Universal Joint**

## UNIVERSAL JOINTS (Cont.)

### CONSTANT VELOCITY TYPE

**NOTE** — To prevent damage to constant velocity joint, center ball when removing propeller shaft assembly. When handling shaft after removal, support shafts on both sides of constant velocity joint if shaft is being moved horizontally. Do not allow one end to hang free or one shaft to bend at a sharp angle. After removal, shaft may be carried vertically without damage.

**Disassembly; General Motors & Jeep** — 1) Disconnect yoke attaching bolts and flange attaching bolts and remove propeller shaft from vehicle. Mark joint so that center yoke, end yoke and crosses will be installed in original positions.

2) Pry out all snap rings and press bearing out enough to allow bearing end to be clamped in a vise. Tap on yoke until it is free of bearing.

3) Repeat procedure for remaining bearings. Remove remaining parts from center yoke assembly.

**Reassembly; General Motors & Jeep** — 1) Pack all bearings with proper grease and assemble center yoke components in reverse order of disassembly.

2) Using arbor press or vise, press two opposing bearings into position at same time until all bearings are installed. Take caution that crosses and yokes remain aligned during this process.

3) Check for free movement of joint. If bind exists, seat bearings with a sharp rap on yokes with brass hammer.

**NOTE** — Never hammer on bearings.

4) Install propeller shaft in vehicle, making sure marks made during disassembly are aligned.

**Disassembly; Ford** — 1) With propeller shaft removed from vehicle, position assembly in a vise. Mark position of crosses, center yoke and center socket in relationship with stud yoke welded to propeller shaft tube.

**NOTE** — Crosses will have to be installed on bosses in original positions to obtain correct clearance.

2) Remove snap rings in front of center yoke. Using a "C" clamp type tool (CJ91B or equivalent), tighten screw in tool until bearing protrudes  $\frac{3}{8}$ ".

3) Remove propeller shaft from vise. Tighten protruding part of bearing in vise, then rap against center yoke with hammer until bearing is free of yoke. Remove all bearings from cross in this manner.

4) Remove cross from center yoke. Remove centering socket from stud and remove rubber seal from centering ball stud.

5) Remove snap rings from center and drive shaft yokes. Install "C" clamp tool and tighten screw until bearing is pressing outward and center yoke contacts slinger ring.

**NOTE** — Do not press beyond this point or slinger will be damaged.

6) Clamp exposed end of bearing in vise and hammer on center yoke until bearing is free. Press against cross with "C" clamp tool to remove remaining bearing.

7) Remove center yoke from cross and remove cross from propeller shaft using same procedure.

**Reassembly; Ford** — 1) Clean all components in a suitable solvent. Place cross in drive shaft yoke. Make sure cross bosses are installed in original position.

**NOTE** — If a repair kit is being installed, bosses will be lubrication plugs.

2) Press in bearings and install snap rings. Fill sock and relief ball with proper grease. Position center yoke over cross. Press in bearings and install snap rings.

3) Install a new seal on centering ball stud. Place centering socket over stud. Place front cross in yoke. Make sure cross bosses (or lubrication plugs) are installed in original position.

4) Place cross loosely on center stop. Press first set of bearings into center yoke, then install second set. Install snap rings. Apply pressure to center yoke socket and install remaining bear-

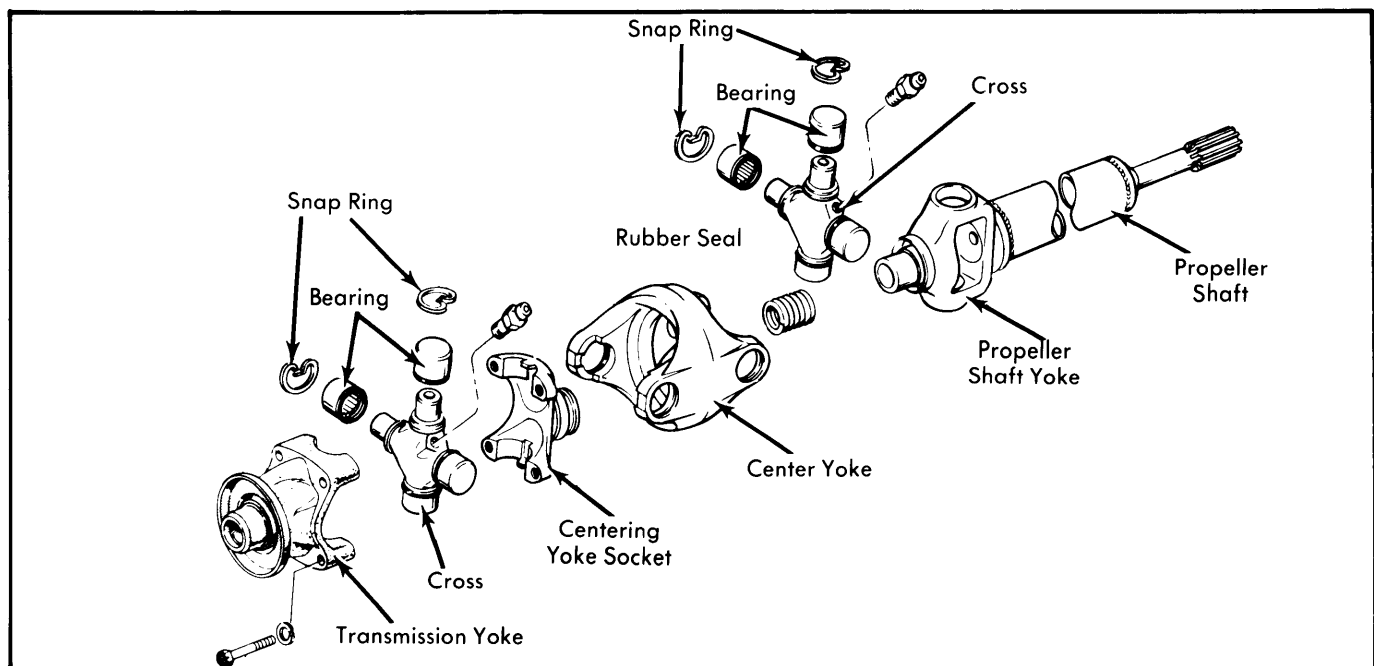

**Fig. 3 Exploded View of Ford Constant Velocity Type Universal Joint**

# Propeller Shafts

## UNIVERSAL JOINTS (Cont.)

ing cup. If replacement kit is used, remove plugs and lubricate "U" joints. Reinstall plugs.

### BALL & TRUNNION TYPE

**Disassembly** – 1) Straighten retainer plate locktabs. Remove plate and gasket from trunion housing. Cut and remove protective boot straps.

2) Push trunion housing and protective boot toward rear of shaft to expose ball and trunion assembly.

3) Remove trunion cap and cap washer. Remove trunion ball needle bearings and trunion ball washer.

4) Remove trunion pin from pin bore in shaft using an arbor press and a suitable mandrel.

5) Remove trunion housing, boot, and boot clip from shaft. Clean all components thoroughly

**Reassembly** – 1) Lubricate all components with chassis grease except boot. Apply a large amount of grease to inside of trunion housing.

2) Position boot clip on raised semi-circular boss on shaft. Use rubber bands or strings to hold clip in position during boot installation.

3) Install protective boot on shaft and install one retaining strap. Make sure boot is seated on raised shaft boss and boot clip before installing strap. Make sure strap is in groove on boot before tightening.

4) Install trunion housing on shaft. Seat protective boot in housing. Install remaining boot strap. Make sure boot is fully seated in housing. Make sure strap is in groove on boot before tightening.

5) Place shaft in arbor press and start trunion pin in shaft bore. Press pin in bore until pin is centered in shaft.

**NOTE** – Make sure trunion pin projects an equal distance from each side of shaft. Pin must be centered within .006" of an inch.

6) Install trunion ball washer on pin and install trunion ball and needle bearings on pin. Install trunion cap washer and trunion cap pin.

7) Move housing forward over ball and trunion assembly. Make sure assembly is fully seated in housing.

8) Install a new gasket and plate on housing. Bend plate locktabs into housing slots to retain plate and gasket.

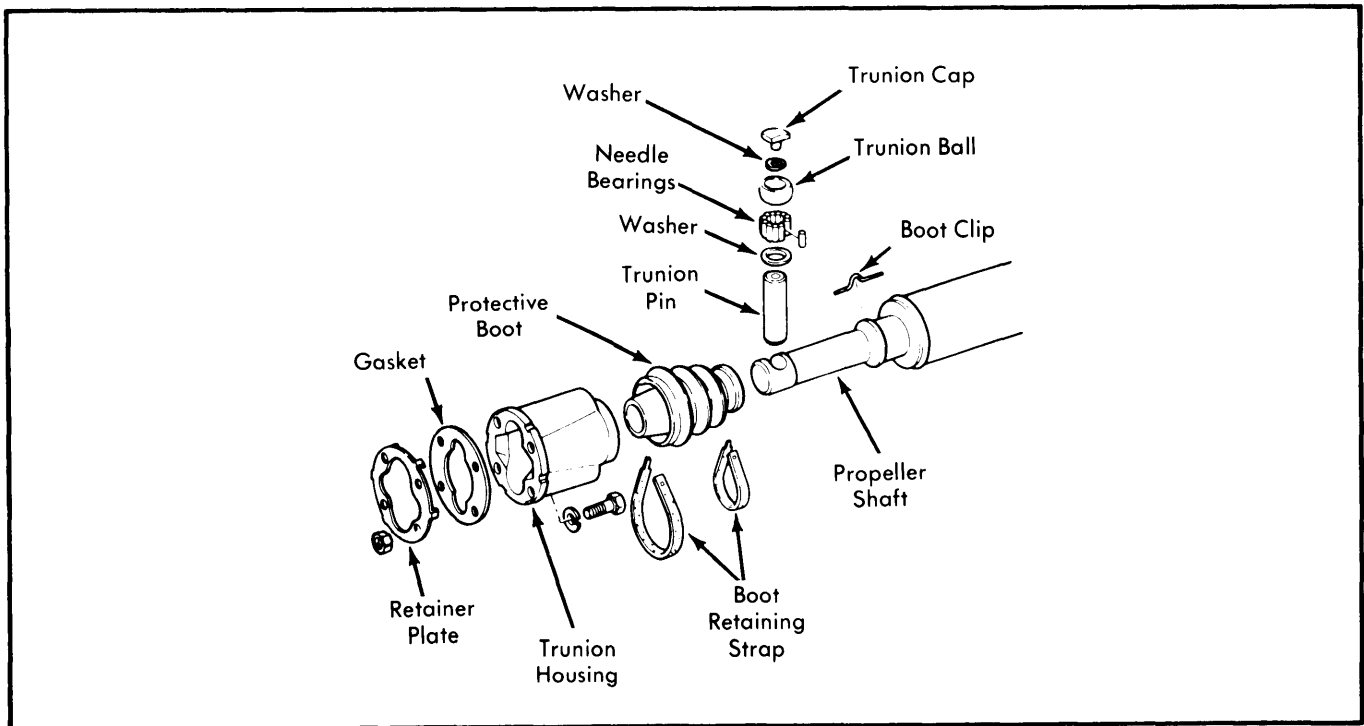

**Fig. 4** Exploded View of Ball and Trunion Universal Joint