

STEERING KNUCKLES

Chrysler Corp.
Ford Motor Co.
General Motors
International Harvester
Jeep

DESCRIPTION

Open type steering knuckles are used on all models. Open type knuckles provide a sharper turning angle which will decrease the vehicle turning radius. All of the vehicle weight is carried by the axle housing and steering knuckle; the axle shafts are free floating. The steering knuckles can be attached to axle housing by either ball joints or roller bearings and pivot pins, depending on vehicle model. Other than the unique components required for front-wheel drive, all steering knuckles used on light duty truck application are mechanically identical.

OVERHAUL

BALL JOINT TYPE

Disassembly — 1) Remove wheel, disc brake caliper and locking hub (if equipped). See *appropriate Locking Hub article in this Section*. Remove disc brake rotor and hub. Remove spindle. Examine axle bore of knuckle. If a seal is present, drive out from inside with a punch. Slide axle shaft out through steering knuckle.

2) Disconnect steering rod(s) from knuckle. Remove nut from lower ball joint stud. Examine underside of knuckle; if a snap ring is present that retains lower ball joint socket, remove snap ring. Remove cotter pin from upper ball joint nut, then screw nut up until it is flush with top of ball joint stud. Using suitable adapter plate and pulling tool, loosen steering knuckle from axle-end yoke. Remove upper ball joint nut, and remove steering knuckle.

3) Using suitable tools, press ball sockets from knuckle. Remove threaded sleeve from yoke. Clean all components with suitable solvent and blow dry with compressed air. Inspect all parts for burrs, chips, wear, flat spots or cracks. Replace all damaged parts and parts showing excessive wear.

Reassembly — 1) Place new lower ball socket into position on knuckle. Lower socket has shorter shaft and no cotter pin hole. Using a suitable adapter, press into place in bore. Check bore to socket clearance; it must be less than .0015". Install snap ring, if equipped. Install upper socket into knuckle. Check clearance as with lower socket. Install threaded sleeve into axle end yoke.

2) Adjust threaded sleeve so that approximately two threads are exposed above top of yoke. Assemble knuckle to yoke. Install NEW nut on bottom ball joint and tighten to specifications. Tighten threaded sleeve to specifications (this loads ball joints correctly). Install ball joint upper nut and tighten to specifications. To complete reassembly, reverse disassembly procedure.

NOTE — When aligning upper ball joint nut to install cotter pin, always tighten nut to align. Never loosen nut to align holes.

PIVOT PIN TYPE

Disassembly — 1) Remove wheel, disc brake caliper and locking hub (if equipped). See *appropriate Locking Hub article in this Section*.

2) Remove disc brake rotor and hub. Remove spindle from steering knuckle. Slide axle shaft out through steering knuckle. Disconnect steering linkage at knuckle.

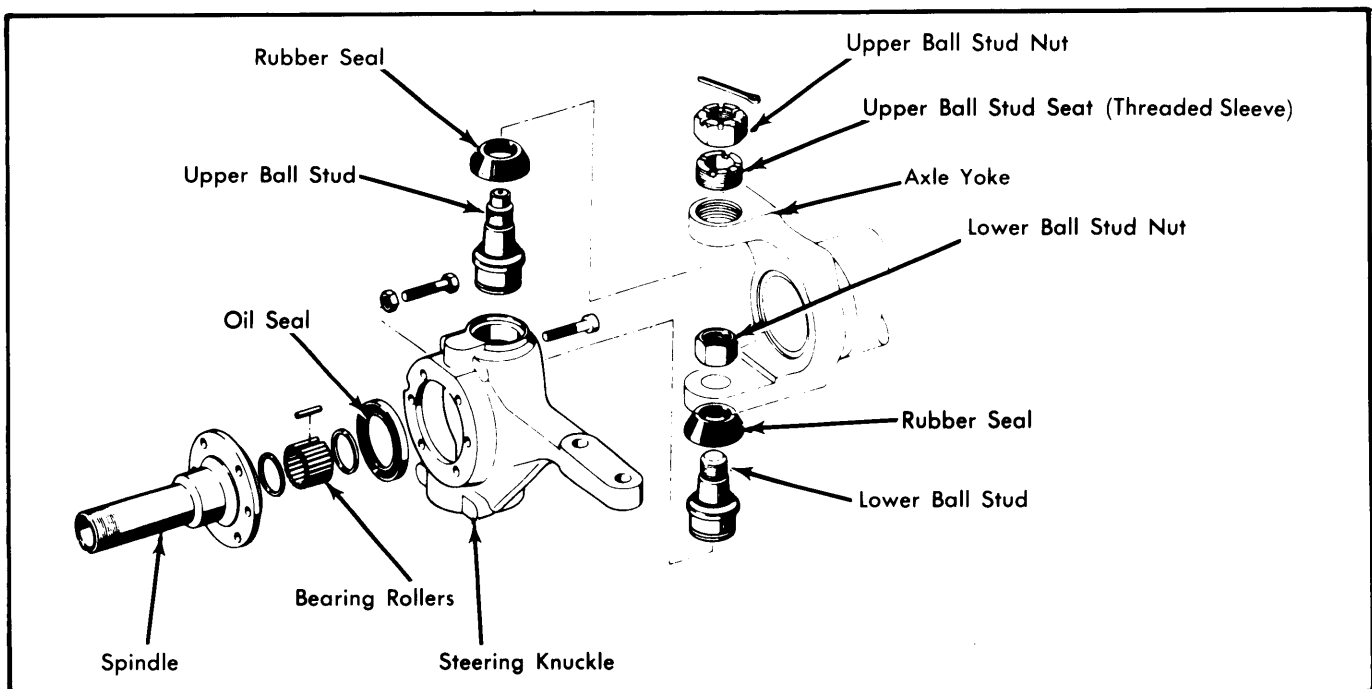

Fig. 1 Exploded View of Ball Joint Type Steering Knuckle Assembly

STEERING KNUCKLES (Cont.)

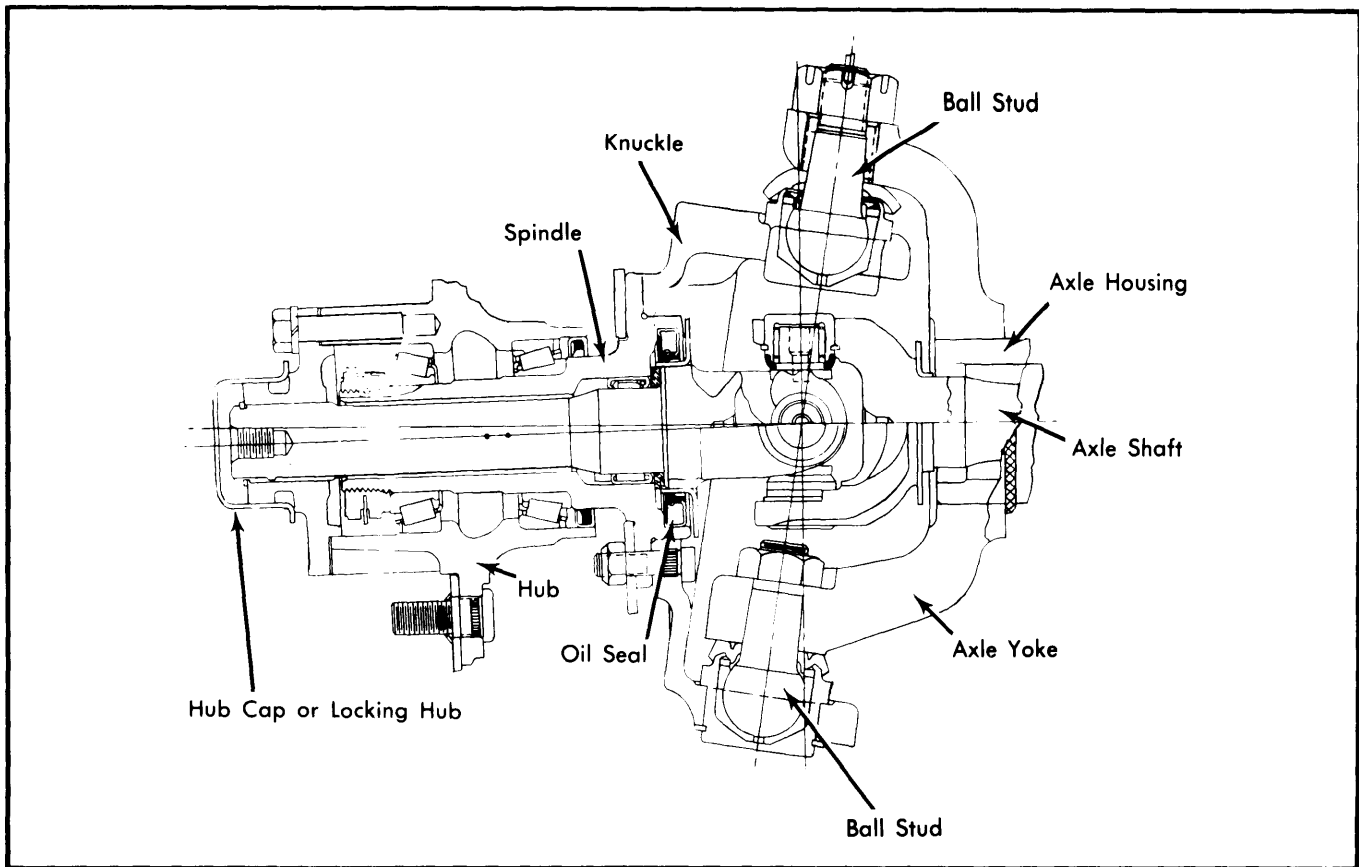

Fig. 2 Sectional View of Ball Joint Type Steering Knuckle Assembly

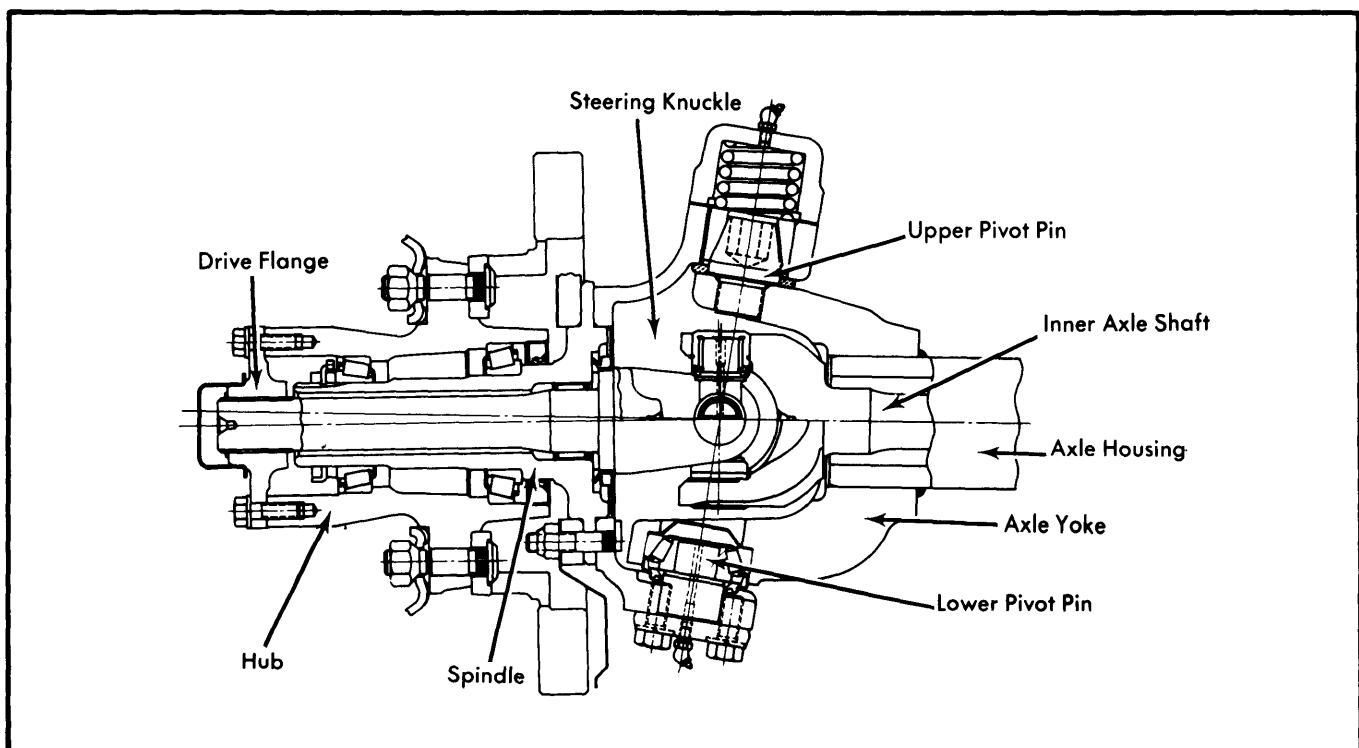

Fig. 3 Sectional View of Pivot Pin Type Steering Knuckle Assembly

4-Wheel Drive Steering Knuckles

STEERING KNUCKLES (Cont.)

3) Remove nuts from upper pivot pin cap. Remove nuts alternately as spring will force cap up. Remove cap, compression spring and gasket.

4) Remove nuts from lower cap. Remove cap and pivot pin. Remove upper pivot pin tapered bushing and knuckle from axle yoke. Remove upper pivot pin from yoke using a suitable puller.

5) Drive out lower pivot pin bearing cup, cone, grease retainer and seal with a punch. Drive out from top to bottom.

Reassembly – 1) Install a new grease retainer and bearing cup in bottom of yoke. Fill grease retainer with a suitable lubricant. Grease bearing cone and install in cup.

2) Install a new lower pivot pin oil seal. Care must be taken not to distort seal as it is driven into place. It will protrude slightly from surface of yoke.

3) Install upper pivot pin using a suitable socket. Installation torque is 500-600 ft. lbs.

4) Position felt seal on pivot pin. Install steering knuckle and tapered bushing on pivot pin. Install lower bearing cap and pivot pin. Tighten bolts alternately and evenly to specification.

5) Install compression spring on upper pivot pin bushing. Install bearing cap using a new gasket. Tighten nuts alternately and evenly to specification.

ADJUSTMENT

BALL JOINTS

1) Raise vehicle and position on safety stands. Disconnect tie-rod at steering knuckle. Connect a spring tension gauge to tie-rod hole in steering knuckle.

2) Place steering knuckle in straight ahead position. Measure force required to pull steering knuckle to the right after initial breakaway.

3) The pull should not exceed 25 ft. lbs. If pull required exceeds 25 ft. lbs., remove upper ball joint stud nut and loosen adjusting sleeve as required.

TURNING ANGLE

Turning angle stop screws are located at rear of steering knuckle just above axle centerline. To adjust, loosen lock nut on turning angle stop screw. Using a turntable to measure angle, adjust stop screw to obtain specified angle, then tighten lock nut without changing setting.

Turning Angle Specifications

Application	Degrees
Jeep	
"CJ" Models	29
All Others	36-37
International Harvester	37-38

NOTE – Turning angle adjustment applies only to Jeep and IHC vehicles.

TIGHTENING SPECIFICATIONS

Application	Ft. Lbs.
Ball Joint Type	
Threaded Sleeve (Upper Ball Stud Seat)	
Ford & Chrysler Corp.	40
All Others	50
Upper Ball Joint Nut	
Chrysler Corp.	135
All Others	100
Lower Ball Joint Nut	
Chrysler Corp.	135
All Others	80
Pivot Pin Type	
Pivot Pin Cap Bolts	70-90
Drag Link to Steering Knuckle	60
Tie Rod to Steering Knuckle	45