

AMC/JEEP 8 7/8" RING GEAR

Jeep (CJ Models)

DESCRIPTION

The AMC/Jeep 8 7/8" ring gear axle assembly is the hypoid gear type with integral carrier housing. Unit is used as rear drive axle on all CJ models. Unit is semi-floating axle type with tapered axle shafts. Pinion bearing preload is adjusted with a collapsible spacer. Side bearing preload is adjusted by varying shim thickness. A removable housing cover allows access to differential for inspection or minor servicing without removing axle assembly.

AXLE RATIO & IDENTIFICATION

The AMC/Jeep 8 7/8" ring gear drive axle can be identified from other units by number of cover bolts. The AMC/Jeep unit has a 12 bolt cover while all others used by Jeep have a 10 bolt cover. Some Jeep models use a Dana/Spicer axle. Refer to the Dana/Spicer Semi-Floating or Full-Floating articles in this section for correct identification. All models with Trac-Lok differential have a tag secured to cover by 1 cover bolt. Tag indicates that only Jeep Trac-Lok differential lubricant be used. To determine drive axle ratio, refer to Drive Axle Ratio Identification in this Section.

REMOVAL & INSTALLATION

AXLE HUB

Removal — Remove dust cap, nut and washer. Raise vehicle and remove wheel and tire. Remove drum retaining screws and remove drum. Using a suitable puller (J-25109) remove hub. Inspect hub for loose or damaged wheel studs. Check keyway and tapered center bore for wear or cracks and replace hub if necessary.

NOTE — Installation procedures for a new hub and an old hub will differ. If axle shaft is replaced, hub must also be replaced, but a new hub can be installed on an old axle shaft.

Installation (Original Hub) — Align axle key and hub keyway. Slide hub onto axle shaft as far as possible. Install nut and washer, drum, retaining screws, and wheel and tire. Lower vehicle and tighten nut to 250 ft. lbs. Tighten nut to align cotter key hole, DO NOT back nut off.

Installation (New Hub) — 1) Align axle key and hub keyway. Slide hub onto axle shaft as far as possible. Install two lubricated thrust washers and axle shaft nut. Install drum, retaining screws, and wheel and tire. Lower vehicle.

2) Tighten axle shaft nut until distance from outer hub face to end of axle is 1 5/16". **NOTE** — Pressing hub on at this dimension is necessary to form hub serrations correctly. Remove axle shaft nut and one washer. Install nut and tighten to 250 ft. lbs. Tighten nut to align cotter key hole, DO NOT back off nut.

AXLE SHAFTS & BEARINGS

Removal — Remove axle hub as previously outlined. Disconnect parking brake cable at equalizer, and brake line at wheel cylinder. Remove backing plate, oil seal, and shims from axle shaft. **NOTE** — If both axles are removed, keep

shims separated as axle shaft end play is adjusted on left side only. Using a suitable puller (J-2498) remove axle shaft. Remove and discard inner seal. Bearing cone is press fit on axle shaft and must be removed using an arbor press and suitable mandrels.

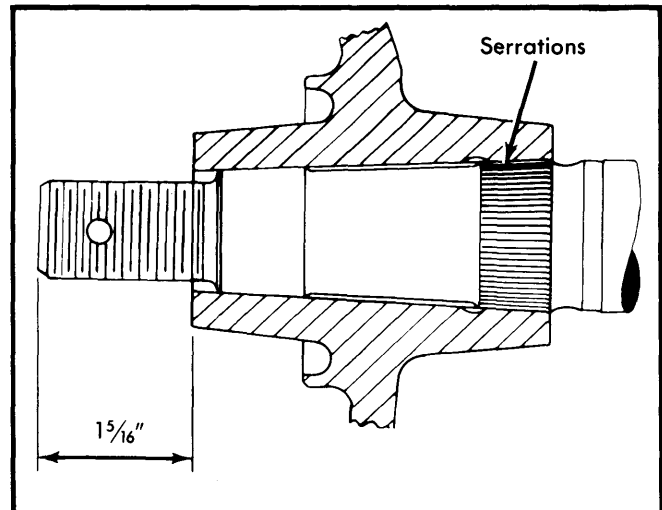

Fig. 1 View Showing Hub Installation Measurement

Installation — 1) Press new axle bearing onto shaft with small diameter of cone toward outer end of shaft. Coat inner axle shaft seal with a light coat of oil. **NOTE** — Tapered axle shaft bearings have no provision for lubrication and should be packed with a good wheel bearing lubricant before installation. Coat outer surface of metal retainer with nonhardening sealer. Install inner seal in axle housing using a suitable installer (J-21788).

2) Place axle shaft in housing and align splined end with differential gears. Install outer bearing cup. Coat backing plate with sealer at mounting area. Install original shims, oil seal assembly, and backing plate. Tighten backing plate bolts to 35 ft. lbs. Oil seal and retainer are located on outside of backing plate. If left axle was removed, end play must be adjusted.

3) To adjust end play, remove left axle hub if not previously removed. Strike ends of both axles with a lead hammer to seat bearings. Attach a suitable tool and dial indicator to left axle. Move axles back and forth to measure end play. End play should be .004-.008" with .006" recommended. Add shims to increase end play and remove shims to decrease end play. Install hub and drum as previously outlined. Adjust brakes and bleed brake hydraulic system.

PINION FLANGE & SEAL

Removal — Raise and support vehicle and remove both rear wheels and tires, and brake drums. Disconnect propeller shaft from flange. Mark propeller shaft position with flange. Connect an INCH Lb. torque wrench to flange nut. Rotate several times and measure torque required to turn pinion.

AMC/JEEP 8 7/8" RING GEAR (Cont.)

Record reading for assembly. Hold flange and remove nut. Mark position of flange on drive pinion. Discard pinion nut. Using a suitable puller, remove flange. Pry out old seal and discard.

Installation — Coat seal lip with axle lubricant before installing. Install seal using a suitable installer tool (J-22661). Align drive pinion shaft and flange marks and install flange on drive pinion. Tighten nut only enough to remove end play. Check torque required to turn drive pinion. Refer to reading recorded during flange removal. Tighten nut enough to exceed recorded reading by 5 INCH Lbs. Repeat these steps until desired nut torque is obtained. **CAUTION** — Do Not loosen and retighten nut. Do Not overtighten nut, if correct torque is exceeded, a new collapsible spacer must be installed and drive pinion preload must be reset. Install propeller shaft aligning marks. Install brake drums and wheels and tires.

AXLE ASSEMBLY

Removal — Raise and support vehicle forward of rear springs. Remove wheels and tires. Mark propeller shaft position with flange and disconnect propeller shaft. Disconnect shock absorbers and brake line at "T" fitting. Plug open ends of lines to prevent dirt entering system. Disconnect parking brake cable at equalizer. Support axle housing with a floor

jack. Remove "U" bolts at spring. If vehicle has springs mounted below axles, disconnect shackle bolts and lower spring from axle. Slide axle housing out from under vehicle.

Installation — To install axle assembly, reverse removal procedure. Bleed brake hydraulic system and check axle lubricant level.

OVERHAUL

DISASSEMBLY

NOTE — It is not necessary to remove complete axle assembly from vehicle for overhaul.

1) Remove axle shaft dust caps and retaining nuts. Raise and support vehicle. Remove axle housing cover and drain lubricant. Remove axle hubs as previously outlined. Mark differential side bearing caps with a center punch for reassembly. Loosen bearing cap bolts until they are retained by just a few threads, then pull bearing cap back on bolts. This will prevent differential from falling out. Pry differential loose in housing. Now remove bearing caps and differential. Secure bearing shims to their respective bearing caps and cups.

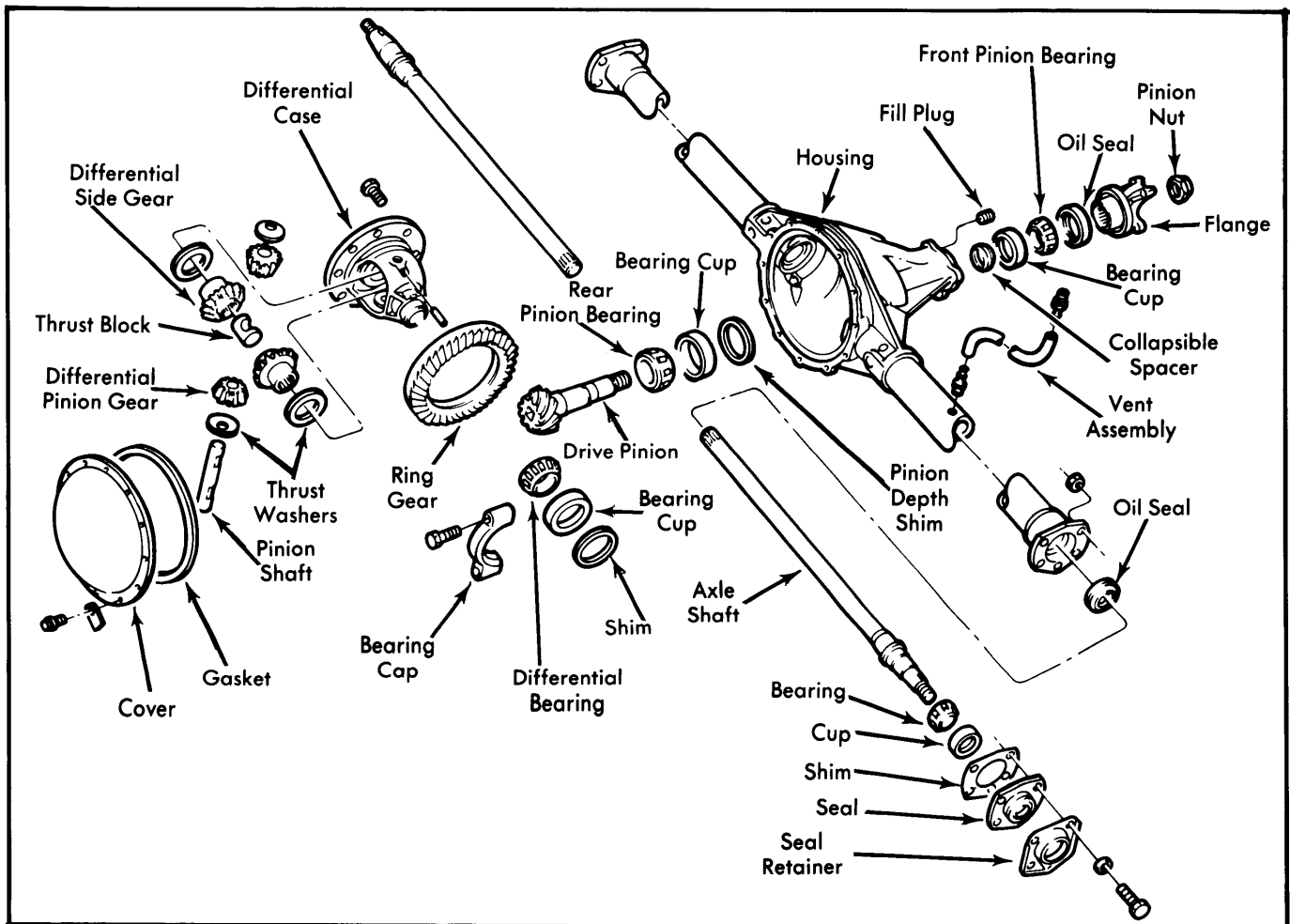

Fig. 2 Exploded View of Drive Axle Assembly

Drive Axles

AMC/JEEP 8 7/8" RING GEAR (Cont.)

2) Use a suitable puller to remove side bearings from differential. Make sure puller pulls against bearing cone and not bearing cage or rollers. Remove ring gear retaining bolts and tap ring gear off differential using a brass hammer. Drive out pinion shaft lock pin using a drift punch. Now drive out pinion shaft using a punch. With shaft removed, withdraw thrust block. Roll pinion gears around on side gears until they can be removed. Now remove side gears and thrust washers.

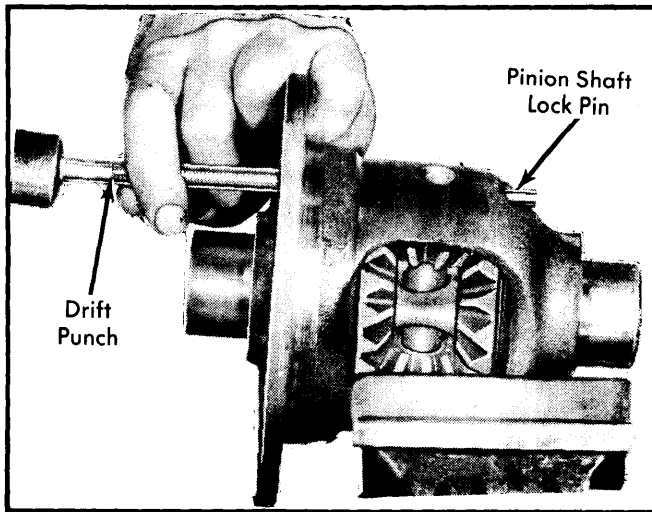

Fig. 3 View Showing Removal Procedure For Pinion Shaft Lock Pin

3) With propeller shaft removed, hold flange with a suitable tool and remove flange retaining nut. Remove flange using a suitable puller. Install housing cover with two bolts. Remove pinion seal. Strike end of drive pinion with a soft mallet. This will unseat front bearing cone from gear. Remove bearing cone. Remove and discard collapsible spacer. Remove housing cover, drive pinion, and rear bearing. Remove front and rear bearing cups using a slide hammer and a suitable adapter. Pinion depth shims are behind rear bearing cone. Secure shims to cone for reassembly reference.

CLEANING & INSPECTION

Clean all components in a suitable solvent. Allow bearings to air dry. Inspect all machined surfaces for smoothness or raised edges. Inspect all bearings and cups for wear or pitting and replace as necessary. Inspect all gear teeth for wear or chipping and replace as necessary. Inspect all splined components for wear or damage and replace as necessary.

REASSEMBLY & ADJUSTMENT

Drive Pinion (Installation & Depth Adjustment) – 1) Pinion gear depth is distance from end face of pinion to the axle shaft centerline. This dimension is controlled by shims installed between pinion rear bearing and axle housing. See Fig. 4.

2) There are 2 numbers painted on pinion gear and one number painted on ring gear. The first number on pinion gear and number on ring gear identify both as a matched set.

NOTE – Ring and pinion gears should not be used if these numbers do not match.

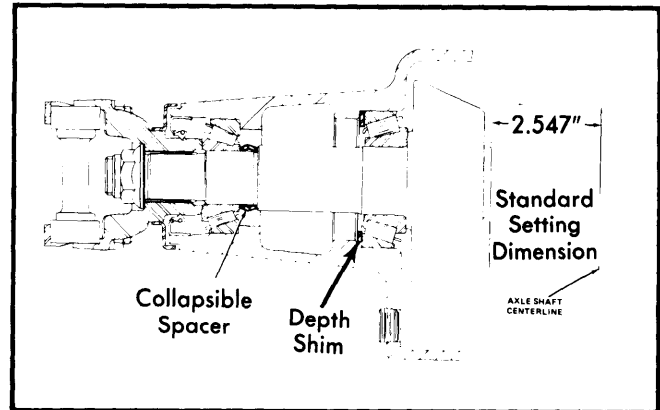

Fig. 4 Sectional View Showing Pinion Depth, Shim Location and Collapsible Spacer Location

3) Second number on pinion gear represents pinion depth variance. This indicates (in thousandths of an inch) the amount that ring and pinion gear varied from standard setting to obtain the correct gear tooth contact pattern.

EXAMPLE: Standard pinion depth is 2.547". If pinion gear is marked 2, the set varied from the standard setting by .002". This means that .002" less shim will be required than a gear set marked 0.

NOTE – Some factory installed sets may have .010" or .020" machined off the pinion gear end face. Identifying numbers will appear different. For example, if gear is machined .010", the identifying number will appear as +16. This indicates that .010" was removed from end face and that pinion depth variance is .006". A gear machined .020" would be identified in the same manner only a 2 will be used rather than a 1.

4) To determine a starter shim thickness to measure pinion depth and determine the correct shim thickness, measure thickness of shim removed during disassembly. Note pinion depth variance on old and new pinion gears.

5) Using Pinion Depth Variance Chart, determine amount to be added or subtracted from original shim thickness to determine starter shim thickness.

EXAMPLE: If the old pinion is marked -3 and the new pinion is marked +2, the chart indicates -.005". This means that .005" would be reduced from original shim thickness to determine starter shim.

NOTE – Do not use starter shim thickness as final shim thickness.

6) Install rear bearing on pinion gear. Make sure large diameter of bearing cage faces gear end of pinion. Make sure bearing is fully pressed against rear face of gear.

7) Make sure pinion gear bearing bores are clean in housing. Install starter shim in rear bearing cup bore. If shim is chamfered, make sure chamfered side faces bottom of bore.

8) Install front and rear bearing cups using suitable mandrels and drivers. Install pinion gear in position in housing.

AMC/JEEP 8 7/8" RING GEAR (Cont.)

9) Install front bearing, rear universal joint yoke and original pinion nut. Tighten pinion nut only enough to remove all end play.

NOTE — Do not install a new pinion nut or collapsible spacer at this time. These will be installed when pinion bearing preload is adjusted.

10) Note pinion depth variance marked on pinion gear. Add or subtract this from standard pinion depth. This is correct pinion depth. Record this figure.

11) Assemble pinion depth measuring gauge arbor tool (J-5223-4) and centering discs (J-5223-23). Install gauge assembly, with discs fully seated, in differential bearing cup bores. Install bearing caps and tighten bolts securely.

12) Position gauge block (J-5223-20) on end face of pinion. Make sure anvil end of gauge block is seated on gear and gauge block plunger is under arbor tool.

13) Attach gauge block clamp (J-5223-14) to housing using a housing cover bolt. Tighten clamp bolt down against gauge block to prevent block from moving. See Fig. 5.

14) Loosen gauge block thumb screw and allow gauge block plunger to contact arbor tool. Now tighten thumb screw securing plunger in position. Remove clamp and then remove gauge block.

15) Using a 2 to 3 inch micrometer, measure distance from end of anvil on gauge block to end of plunger. This represents measured pinion depth. Record this measurement.

16) Remove bearing caps, then remove arbor and disc assembly. Remove pinion gear, bearing cup and depth shim from axle.

17) Measure thickness of starter shim. Add this to measurement obtained in step 15). From this total, subtract desired pinion depth measurement obtained in step 10). The result is the shim thickness required to obtain correct pinion depth.

EXAMPLE:

Standard Pinion Depth 2.547"
 Pinion Depth Variance +.007"
 Desired Pinion Depth =2.554"

Measured Pinion Depth 2.550"
 Starter Shim Thickness +.098"
 Total Measured Pinion Depth =2.648"

Total Measured Pinion Depth 2.648"
 Desired Pinion Depth -2.554"
 Correct Shim Thickness =.094"

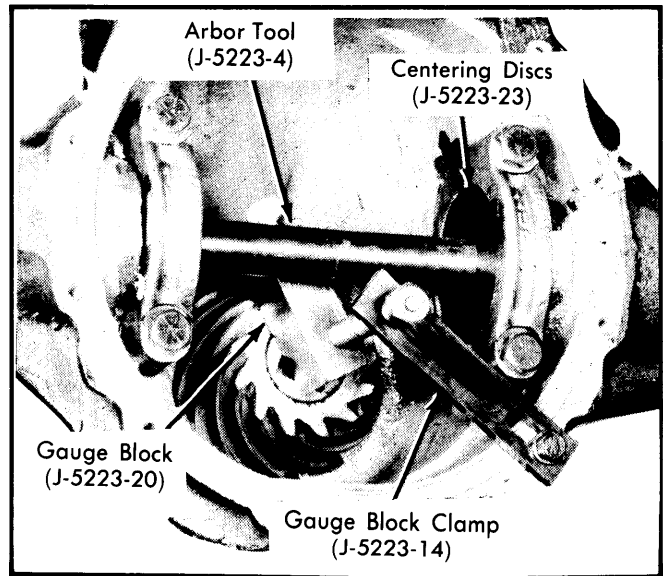

Fig. 5 Measuring Pinion Depth

Drive Pinion Bearing Preload — 1) Install correct pinion gear depth shim(s) in housing bore. Install pinion gear and rear bearing.

2) Install new collapsible spacer and front bearing in housing. Drive in a new pinion oil seal. Install universal joint yoke and a new retaining nut. Tighten nut finger tight.

PINION DEPTH VARIANCE CHART									
Old Pinion Marking	New Pinion Marking								
	-4	-3	-2	-1	0	+1	+2	+3	+4
+4	+0.008	+0.007	+0.006	+0.005	+0.004	+0.003	+0.002	+0.001	0
+3	+0.007	+0.006	+0.005	+0.004	+0.003	+0.002	+0.001	0	-0.001
+2	+0.006	+0.005	+0.004	+0.003	+0.002	+0.001	0	-0.001	-0.002
+1	+0.005	+0.004	+0.003	+0.002	+0.001	0	-0.001	-0.002	-0.003
0	+0.004	+0.003	+0.002	+0.001	0	-0.001	-0.002	-0.003	-0.004
-1	+0.003	+0.002	+0.001	0	-0.001	-0.002	-0.003	-0.004	-0.005
-2	+0.002	+0.001	0	-0.001	-0.002	-0.003	-0.004	-0.005	-0.006
-3	+0.001	0	-0.001	-0.002	-0.003	-0.004	-0.005	-0.006	-0.007
-4	0	-0.001	-0.002	-0.003	-0.004	-0.005	-0.006	-0.007	-0.008

Drive Axles

AMC/JEEP 8 7/8" RING GEAR (Cont.)

3) Now hold yoke with a suitable tool and tighten nut. Rotate pinion while tightening to make sure bearings seat evenly.

4) Using an INCH lb. torque wrench, measure torque required to turn pinion. If pinion bearing preload is not to specification, continue tightening yoke retaining nut until correct preload is obtained.

CAUTION — Do not exceed specified torque. If torque is exceeded, a new collapsible spacer must be installed and preload must be readjusted. Do not loosen nut to reduce torque.

Assembling Differential Carrier — 1) Using suitable tools, install differential bearings onto case. Install thrust washers on differential gears (oil pocket side toward gear), then install gears into bores in differential case. Install thrust washers behind differential pinion gears, then mesh gears with differential gears so holes are opposite and in line with each other. Roll gears around until differential pinion gear holes are aligned with shaft holes in case.

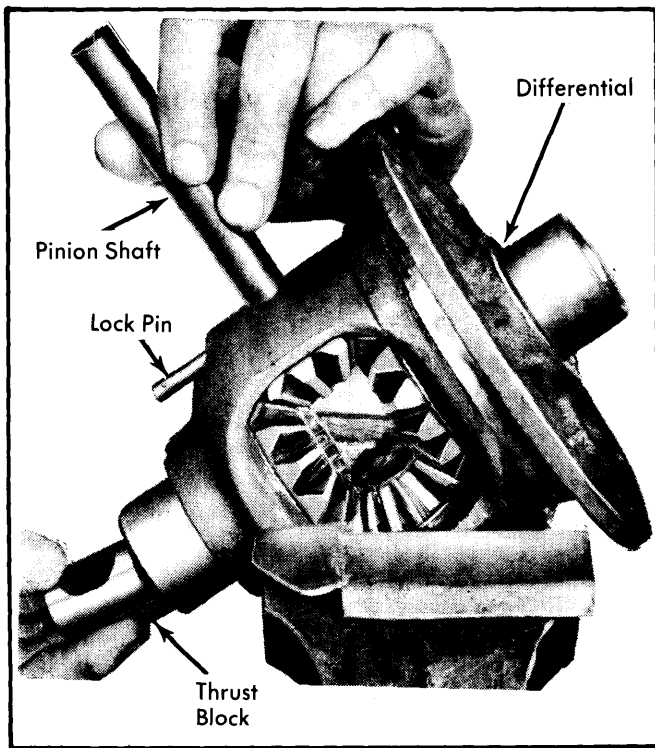

Fig. 6 Installing Pinion Shaft and Thrust Block

2) Install thrust block through a differential gear, aligning hole in block with pinion shaft holes. Install pinion shaft, with lock pin hole in shaft aligned with lock pin hole in case. Measure any existing clearance between differential gears and case, using two feeler gauges on opposite sides of one gear. Clearance should be zero.

Adjusting Differential Bearings — 1) Place bearing cup over each differential bearing, then install differential case assembly in axle housing. As a starting point, install an .080" shim on each side. Install bearing caps and tighten bolts finger tight. Mount a dial indicator to housing so that plunger con-

tacts ring gear mounting flange on differential. Using two screwdrivers, pry between shims and housing. Pry assembly to one side, zero indicator, then pry assembly to opposite side and read indicator. **NOTE** — Do Not read or zero indicator while prying.

2) The amount read on indicator is amount of shim to be added to arrive at a no preload and no end play condition. Shims are available in thicknesses ranging from .080 to .110" in .002" increments. With all side play eliminated, check ring gear mounting flange for runout. Runout should not exceed .002". Remove differential case from housing and retain shims used to eliminate side play.

Ring Gear Installation — Place ring gear on differential housing case and install retaining bolts. Two bolts installed in opposite holes may be used to pull ring gear into place. Tighten bolts to specification.

Backlash Adjustment — Install differential assembly in housing using shims selected to remove side play. Tighten bearing cap screws to 87 ft. lbs. Attach a dial indicator to housing so that indicator plunger contacts drive side of a tooth on ring gear and is at a right angle to it. Rock ring gear and note movement on dial indicator. Backlash should be .005-.009", with .008" desired. To increase backlash, install a thinner shim on ring gear side. To decrease backlash, reverse procedure, however do not change total thickness of shims.

Differential Bearing Preload — 1) Differentials bearings are preloaded by increasing each shim thickness by .004". Install differential bearing shims in axle housing bearing bores. Assemble bearing cups on bearings (cups should completely cover rollers), then position differential so that bearings just start in axle housing bearing bores. Keep assembly square in housing and push in as far as possible. Using a soft hammer, tap outer edge of bearing cups until seated in housing. **CAUTION** — Do Not distort shims by hammering them into housing.

2) Install bearing caps, aligning marks made at disassembly, then install and tighten bolts. Preloading differential bearings may change backlash setting, therefore recheck backlash and correct as necessary. After all adjustments have been made, make a gear tooth pattern check to insure correct assembly. Install propeller shaft, axle shafts, bearings, seals, brake backing plate, hubs and drums, reversing disassembly procedures. Fill rear axle with suitable lubricant.

AXLE ASSEMBLY SPECIFICATIONS

Axle Shaft End Play004-.008"
Pinion Bearing Preload	17-25 INCH Lbs.
Differential Bearing Preload (Shims)008"
Backlash005-.009"
Pinion Gear Depth (Std. Setting)	2.547"

TIGHTENING SPECIFICATIONS

Application	Ft. Lbs.
Differential Bearing Cap Bolts	87
Ring Gear Bolts.....	105
Backing Plate Bolts.....	32
Rear Wheel Hub-to-Axle Nut.....	250 (Min.)
"U" Joint Bolt Clamp.....	13