

454" V8 ENGINE

IDENTIFICATION CODING

ENGINE IDENTIFICATION

Engine code letters are suffix of Engine Identification Number. Number is stamped in pad on front right side of cylinder block.

Chevrolet & GMC

| Application | Man. Trans. | Auto. Trans. |
|---------------------|---------------|-------------------------|
| 454" | | |
| Federal | TRZ,TRT | TRR,TRU,TRS, TRW,TRX |
| Calif. | | TRZ,TRT |
| High Altitude | TRZ,TRT | TRR,TRS,TRU, TRW,TRX |

ENGINE REMOVAL

See *Engine Removal* at end of *ENGINE* Section.

CYLINDER HEAD & MANIFOLD

INTAKE MANIFOLD

Removal - 1) Drain cooling system. Remove air cleaner. Disconnect battery ground cable. Disconnect upper radiator hose and heater hose at manifold. Disconnect water pump bypass at water pump. Disconnect PCV line at valve cover.

2) Disconnect accelerator linkage and fuel inlet line at carburetor. Disconnect vacuum line at distributor. Remove distributor cap and mark rotor position. Remove distributor. Remove air cleaner bracket, accelerator return spring bracket and accelerator bellcrank.

3) If equipped with air conditioning, remove compressor and bracket without disconnecting lines and lay aside. Remove upper alternator mounting bracket. Remove intake manifold bolts and pry manifold loose. Remove manifold with carburetor attached and discard all gaskets.

Installation - To install intake manifold, clean all gasket surfaces and apply sealer at all water passages and at positions where seals butt together. Install manifold and tighten bolts in sequence shown in illustration. Install distributor noting marked position of rotor. To complete installation, reverse removal procedure.

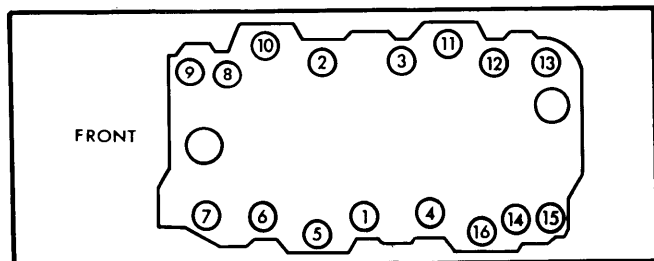

Fig. 1 Diagram Showing Correct Intake Manifold Tightening Sequence

CYLINDER HEAD

Removal - 1) Remove intake manifold as previously outlined. Remove carburetor air heater from exhaust manifold (if equipped). Remove spark plugs. Disconnect exhaust pipes at exhaust manifolds. Remove exhaust manifolds.

2) Disconnect PCV hose from valve cover. Remove valve covers. Loosen rocker arm nuts and pivot rocker arms to side. Remove push rods. Mark or identify push rods to ensure that they are installed in original positions.

3) Drain cylinder block of coolant. Remove all cylinder head bolts. Pry cylinder head loose from cylinder block and remove cylinder head.

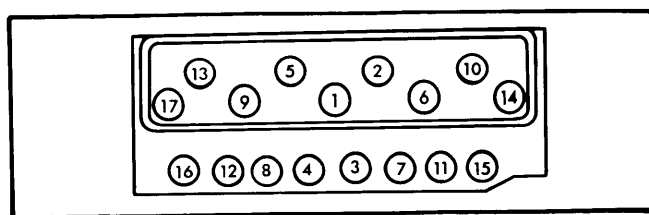

Fig. 2 Diagram Showing Correct Cylinder Head Tightening Sequence

Installation - Reverse removal procedure to install cylinder heads. Ensure that gasket surfaces on head and cylinder block are clean and that cylinder head bolts threads and threads in block are clean. If cylinder head gasket is steel type, coat both sides with a suitable sealer. Asbestos gasket requires no sealer. Coat cylinder head bolt threads with sealer. Tighten cylinder head bolts in sequence shown in illustration.

VALVES

VALVE ARRANGEMENT

E-I-E-I-E-I-E-I (Left bank, front to rear.)

I-E-I-E-I-E-I-E (Right bank, front to rear.)

VALVE GUIDE SERVICING

If valve stem to guide clearance is excessive, valves with over-size stems are available. Use a suitable reamer (J-7049) to ream guides to correct size for over-size valve stems.

VALVE STEM OIL SEALS

An umbrella type oil seal is installed on valve stem before valve spring is installed. See *Valve Springs*.

VALVE SPRINGS

Removal - With cylinder head removed, compress valve spring with a suitable spring compressor and remove valve keepers. Release spring compressor and remove retainer, spring and damper, seal and valve rotators (if equipped).

Installation - To install valve springs, reverse removal procedure. Lubricate and install valve stem oil seal on valve stem before installing remaining components.

454" V8 ENGINE (Cont.)

VALVE SPRING INSTALLED HEIGHT

Valve spring installed height is measured from top of shim at bottom of spring, or spring seat to top of valve spring. If distance exceeds specified height, install a $\frac{1}{16}$ " thick shim. Installed height should never be more than $\frac{1}{16}$ " less than specified height.

| Application | Valve Spring Installed Height | Height |
|-------------|-------------------------------|-------------------|
| All | | 1 $\frac{7}{8}$ " |

ROCKER ARM STUDS

Push rod guides are attached to cylinder head by rocker arm studs. Replace as necessary and torque studs. Coat threads on cylinder head end of new stud with sealer.

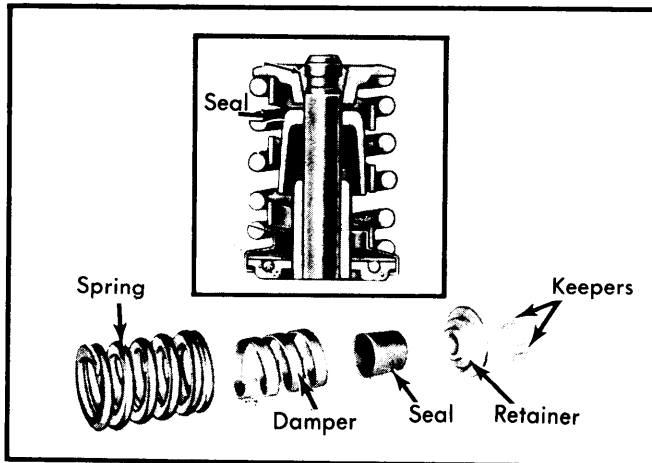

Fig. 3 Exploded View of Valve Spring Assembly

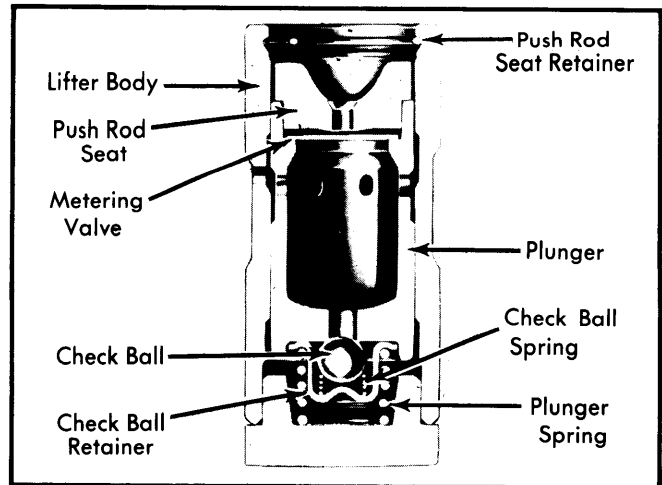

Fig. 4 Cutaway of Hydraulic Valve Lifter Assembly

VALVE CLEARANCE ADJUSTMENT

1) Rotate engine until timing marks are aligned and No. 1 cylinder is in firing position. Back off rocker arm adjusting nuts on number one intake and exhaust rocker arms until play in push rod is detected. Now tighten rocker arm nut until play in push rod is just eliminated, then tighten adjusting nut one full turn more. With engine at number one firing position, adjust intake valves 1, 2, 5 and 7 and exhaust valves 1, 3, 4 and 8.

2) Rotate engine to number 6 firing position and follow same procedures for adjusting valves. With engine at number 6 firing position, adjust intake valves 3, 4, 6 and 8 and exhaust valves 2, 5, 6 and 7.

PISTONS, PINS & RINGS

OIL PAN REMOVAL

See *Oil Pan Removal* at end of *ENGINE* Section.

PISTON & ROD ASSEMBLY

Removal — With oil pan, oil pump and cylinder heads removed, remove any ridge in top of cylinder bore with a suitable ridge reamer. Check connecting rod and cap for identification marks or numbers and identify if necessary. Remove connecting rod cap nuts and rod cap. Push piston and rod assembly up and out of cylinder block. It will be necessary to rotate crankshaft to various positions to facilitate removing piston and rod assemblies.

Installation — Before installing piston and rod assembly, position ring gaps in positions shown in illustration. Place connecting rod in bore with bearing tang slots facing away from camshaft. Compress piston rings with a suitable ring compressor. With rod bearings and crankshaft journal lubricated, push piston and rod assembly into position and install rod cap to respective rod. Install and tighten rod nuts.

HYDRAULIC VALVE LIFTER ASSEMBLY

Disassembly — Depress plunger in lifter with a push rod and pry out retainer with a small blade screwdriver. Remove push rod seat and metering valve. Remove plunger, ball check valve assembly and plunger spring. Remove ball check valve and spring by prying ball retainer loose with a small blade screwdriver.

Assembly — 1) Thoroughly clean and inspect all components. If any components are worn or damaged, complete lifter must be replaced. Position check ball on small hole in bottom of plunger. Insert check ball spring on seat in ball retainer and position retainer on ball so that spring seats on ball. Using a screwdriver, press plunger into position.

2) Slide lifter body over spring and plunger, lining up oil feed holes. Fill assembly with SAE 10 oil and depress plunger to stop. With plunger depressed, insert a $\frac{1}{16}$ " drift punch into feed holes. Release plunger and refill with SAE 10 oil. Install metering valve, push rod seat and retainer. Depress push rod seat and remove drift punch.

454" V8 ENGINE (Cont.)

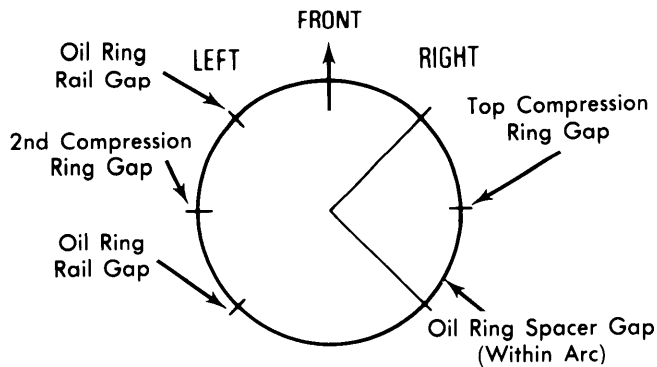

Fig. 5 Desired Ring Gap Locations

FITTING PISTONS

1) With piston and rod assemblies removed, wipe cylinder bores clean and measure diameter of cylinder with a dial indicator. If cylinder is worn or is tapered more than .005", cylinder must be bored for oversize pistons.

2) If bore is worn or tapered less than .005", cylinder can be cleaned and honed, and .001" oversize pistons may be installed. If cylinders are bored, various oversize pistons are available.

3) To check fit of rings in cylinder bore, insert ring in cylinder bore and push ring into bore 2" with head of piston and measure ring end gap with a feeler gauge. Before installing rings on pistons, ensure ring grooves are clean of carbon and inspect grooves for nicks or burrs. Install rings with gaps positioned as shown in illustration.

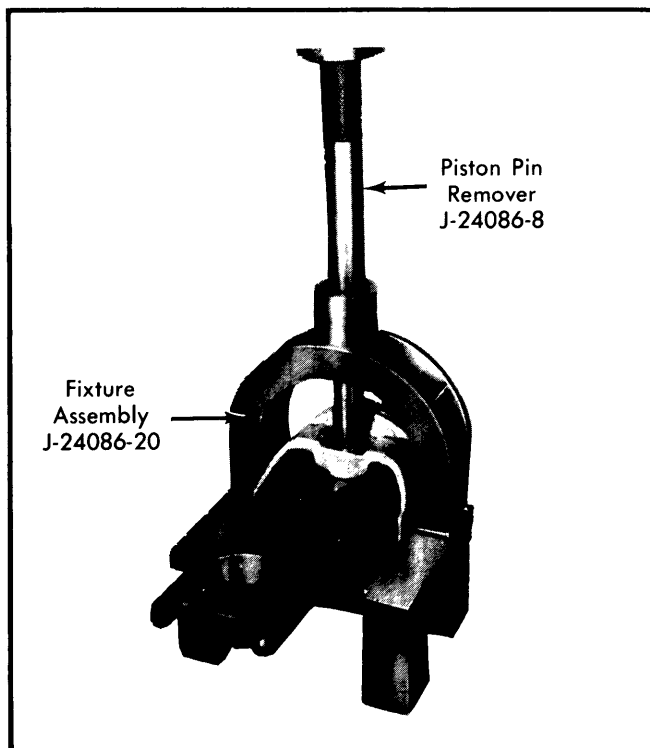

Fig. 6 Removal/Installation of Piston Pin

Removal — With piston and rod assembly removed, press out piston pin using removal and installation tool J-24086 (or equivalent), and an arbor press. Separate piston from connecting rod.

Installation — Check clearance of pin in piston. If clearance exceeds .001" over specified clearance, piston and pin must be replaced. Position piston on rod so that valve notch in top of piston faces to opposite side of bearing tang slots in connecting rod. Lubricate piston pin and press in using same tools as outlined in removal procedure. Check piston for freedom of movement on piston pin.

CRANKSHAFT & ROD BEARINGS

MAIN & CONNECTING ROD BEARINGS

NOTE — Following procedures are performed with oil pan and oil pump removed.

Connecting Rod Bearing — 1) Mark or identify rod cap to rod before removing rod cap nuts. With rod nuts removed, remove rod cap and bearing. Push up on piston and rod assembly and remove bearing from rod. Inspect bearings for wear or damage and replace as necessary.

2) Check crankshaft rod bearing journal for out-of-round or taper conditions. If crankshaft is out-of-round or tapers more than .001", crankshaft must be removed and ground for undersize bearings.

3) Check crankshaft clearance using the Plastigage method. If clearance exceeds specifications, a .001" or .002" undersize bearing may be installed to obtain correct clearance. If clearance is still excessive, crankshaft must be removed and ground for undersize bearings. Connecting rod bearings are available .010" and .020" undersize.

4) To install bearings, clean crankshaft journal and bearing surface in rod. Insert bearing in rod and cap. Lubricate journal and pull piston and rod assembly down, aligning bearing on journal. Install rod cap noting identification marks and evenly tighten rod nuts.

Main Bearings — 1) Main bearings are selective fit by manufacturer during production. A standard size bearing may be used in combination with a .001" undersize bearing to obtain correct clearance. This combination will decrease clearance .0005".

2) If correct clearance could not be obtained during production, a crankshaft with .009" undersize main bearing journals is fitted. A .009" or .010" bearing may be used to obtain correct clearance.

3) If engine is fitted with a crankshaft with .009" undersize main bearing journals, it will be identified by a "9" stamped in crankshaft counterweight along with large spot of light green paint. The bearing cap will also be painted.

454" V8 ENGINE (Cont.)

4) Main bearings may be removed and replaced with crankshaft still installed in engine. Mark or identify main bearing caps to cylinder block before removing caps. Bearings are removed from cylinder block using a bearing removal tool. Install tool in oil hole in crankshaft and rotate crankshaft clockwise.

5) Crankshaft clearance, taper or out-of-round conditions can be checked using the Plastigage method. If clearance exceeds specifications, a .001" or .002" undersize bearing may be installed to obtain correct clearance. Both bearings must be replaced on any journal not within specifications.

6) If correct clearance cannot be obtained or journal tapers or is out-of-round more than .001", crankshaft must be removed and ground for undersize bearings. Bearings are available in standard, .001", .002", .009", .010" and .020" undersize.

7) To install bearings, ensure crankshaft journal and bearing surface in cap and block are clean. Lubricate journal and install bearing cap. If bearings were removed with crankshaft still installed, use bearing removal and installation tool inserted in crankshaft oil hole to install upper bearing. Install main cap noting identification marks and evenly tighten main bearing bolts.

THRUST BEARING ALIGNMENT

Pry crankshaft forward as far as possible and check crankshaft end play with a feeler gauge inserted between front of rear main bearing and crankshaft. Replace rear main bearing if end play is not to specification.

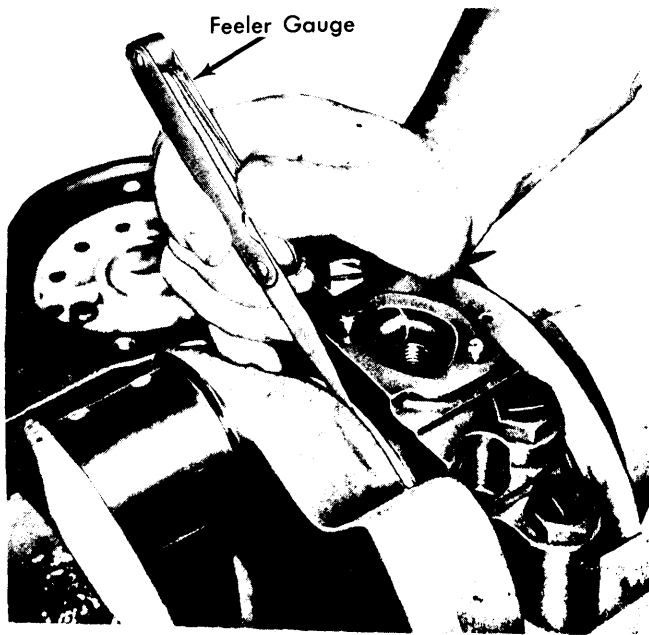

Fig. 7 Using Feeler Gauge to Check Crankshaft End Play

REAR MAIN BEARING OIL SEAL

Removal — Remove rear main bearing cap and pry out old seal. Remove upper half of seal by tapping end with brass punch until end of seal protrudes enough to be removed with pliers.

Installation — 1) Fabricate an installation tool as shown in illustration. Coat seal lips and seal bead of upper seal with motor oil. Keep ends of seal dry of oil and position tool between crankshaft and seal seat in cylinder block. Position seal between tip of tool and crankshaft.

2) Roll seal around crankshaft, using tool as a "shoehorn" to protect seal from sharp corner of seal seat surface. Make sure oil seal lip is positioned towards front of engine. **NOTE** — Installation tool must remain in position until seal is positioned with both ends flush with block. Remove tool, taking care not to remove seal.

3) Install lower half of seal in bearing cap, using tool as a "shoehorn". Feed seal into cap using light pressure with thumb and finger. Install bearing cap with sealant applied to face, taking care to keep sealant off split line.

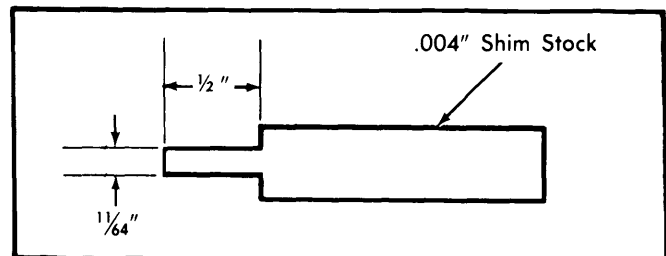

Fig. 8 Rear Main Oil Seal Installation Tool

CAMSHAFT

ENGINE FRONT COVER

Removal — Remove fan belt, fan and pulley. Remove radiator shroud and water pump. Remove accessory drive pulley and harmonic balancer retaining bolt. Remove harmonic balancer with a suitable puller (J-23523). Remove cover retaining screws and pull cover forward slightly. Using a sharp knife, cut oil pan front seal flush with cylinder block. Remove cover and gasket.

Installation — 1) Clean cover, oil pan and cylinder block gasket surfaces. Cut tabs off new oil pan front seal. Install seal in front cover, pressing seal tips in holes provided in cover. Apply a 1/8" bead of RTV sealer to joint formed at oil pan and cylinder block. Install new cover gasket and coat with sealer.

2) Position front cover over crankshaft, press downward against oil pan and push over dowel pins. Slightly tighten two bolts in oil pan, install and tighten remaining bolts. Tighten two oil pan bolts. Oil seal contact surface on harmonic balancer and pull into position using a suitable puller. Install and tighten harmonic balancer bolt. Reverse removal procedure to install remaining components.

FRONT COVER OIL SEAL

With Cover Removed — Pry seal out of cover with a screwdriver. Install new seal with open end of seal toward inside of cover and drive into position with a suitable tool (J-22102). Support cover at seal area before driving in seal.

454" V8 ENGINE (Cont.)

With Cover Installed — With harmonic balancer removed, pry seal out of front cover. Install seal with open end of seal toward engine and drive into place with a suitable driver (J-22102) and a hammer.

TIMING CHAIN & SPROCKETS

Removal — Remove front engine cover as previously outlined. Crank engine over until timing marks on camshaft and crankshaft sprockets are aligned. Remove bolts securing camshaft sprocket to camshaft and pull off sprocket with timing chain. A light blow with a plastic hammer will dislodge sprocket.

Installation — To install new crankshaft sprocket, pull into place with mounting bolts. Install camshaft sprocket and timing chain, making sure timing marks on sprockets are aligned. See Fig. 9. Install and tighten sprocket bolts.

CAMSHAFT

Removal — Remove intake manifold, engine front cover and timing chain as previously outlined. Remove valve covers and loosen all rocker arms until push rods and valve lifters can be removed. Remove grille and radiator if necessary. Remove fuel pump and push rod. Screw two bolts into camshaft and withdraw camshaft.

Installation — Lubricate camshaft journals and lobes with motor oil. If a new camshaft is being installed, coat camshaft lobes with Molykote. Position camshaft to align timing marks on sprockets. Install remaining components as previously outlined. Adjust hydraulic valve lifters.

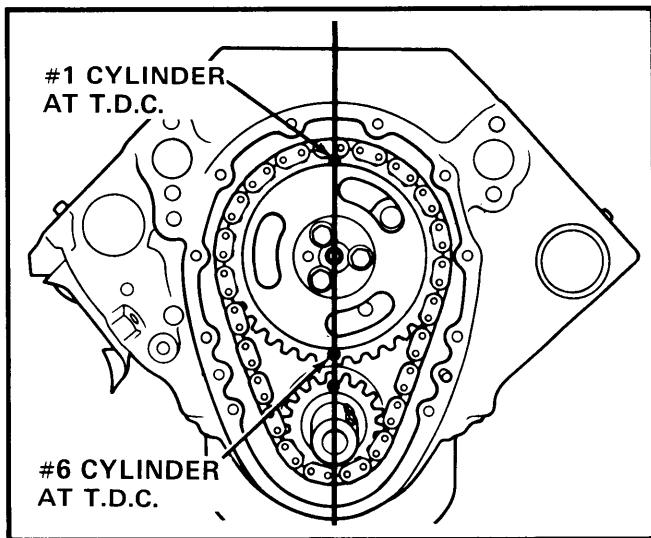

Fig. 9 Timing Chain Sprocket Alignment

CAMSHAFT BEARINGS

Use suitable tools for removal and installation of camshaft bearings. Align oil holes in first four bearings with oil hole in bearing bore in block. Position rear camshaft bearing oil hole at or near 6 o'clock position.

CAM LOBE LIFT

With valve cover removed, remove rocker arm. Mount dial indicator on cylinder head. Position indicator stem on push rod with a suitable adapter (J-8520). Rotate engine slowly until lifter is on heel of camshaft and set dial indicator to "0". Rotate engine slowly until push rod is at fully raised position. Dial indicator will give total camshaft lobe lift. Lift should be within specifications.

ENGINE OILING

Crankcase Capacity — P-30 Step Van, 4 quarts. Add 1 quart with filter change. All other engines 6 quarts. Add 1 quart with filter change.

Oil Pressure — 40 psi at 2000 RPM.

Oil Filter — Replaced every other oil change or more often under dusty conditions.

Pressure Regulator Valve — In oil pump body, nonadjustable.

ENGINE OILING SYSTEM

Full pressure lubrication through a full flow oil filter is furnished by a gear-type oil pump. Main oil gallery feeds oil, through drilled passages, to camshaft and crankshaft to lubricate bearings. Valve lifter gallery feeds the valve lifters, which feed the individual rocker arms through hollow push rods.

OIL PUMP

Disassembly — Mark gears so they may be reassembled with same teeth indexing. Do not disturb pickup screen on pipe. Screen is serviced as an assembly.

NOTE — If pump gears or body are damaged or worn, replacement of entire pump assembly is necessary.

Assembly — Apply sealer to end of pipe and tap in place. Install idler gear in pump body with smooth side of gear towards cover opening.

NOTE — Bottom of screen must be parallel with bottom of pan.

ENGINE SPECIFICATIONS

| TIGHTENING SPECIFICATIONS | |
|------------------------------|----------|
| Application | Ft. Lbs. |
| Cylinder Head Bolts | 80 |
| Intake Manifold | 30 |
| Exhaust Manifold | 20 |
| Main Bearing Caps | 110 |
| Flywheel | 65 |
| Connecting Rod Caps | 50 |
| Camshaft Sprocket | 20 |
| Rocker Arm Stud | 50 |
| Water Pump | 30 |
| Oil Pump | 65 |
| Harmonic Balancer Bolt | 85 |

General Motors V8 Engines

454" V8 ENGINE (Cont.)

ENGINE SPECIFICATIONS (Cont.)

| GENERAL SPECIFICATIONS | | | | | | | |
|------------------------|-----------------|------------|-----------|--------------------------|--------------|--------|--------|
| Year | Displ. Cu. Ins. | Carburetor | HP at RPM | Torque (Ft. Lbs. at RPM) | Compr. Ratio | Bore | Stroke |
| 1979 | 454" | 4-Bbl. | | | 8.5:1 | 4.250" | 4.000" |

| VALVES | | | | | | | |
|----------------|------------|------------|------------|------------|---------------|----------------|------------|
| Engine & Valve | Head Diam. | Face Angle | Seat Angle | Seat Width | Stem Diameter | Stem Clearance | Valve Lift |
| 454" Int. | 2.065" | 45° | 46° | .031-.063" | .3715-.3722" | .0010-.0027" | |
| 454" Exh. | 1.720" | 45° | 46° | .063-.094" | .3713-.3720" | .0012-.0029" | |

| PISTONS, PINS, RINGS | | | | | | |
|----------------------|--------------|----------------|--------------|-------|------------|----------------|
| Engine | PISTONS | | PINS | | RINGS | |
| | Clearance | Piston Fit | ① Rod Fit | Rings | End Gap | Side Clearance |
| 454" | .0014-.0024" | .00025-.00035" | .0008-.0016" | 1 | .010-.020" | .0017-.0032" |
| | | | | 2 | .010-.025" | .0017-.0032" |
| | | | | 3 | .015-.055" | .0005-.0065" |

① - Interference fit.

| CRANKSHAFT MAIN & CONNECTING ROD BEARINGS | | | | | | | |
|-------------------------------------------|------------------|----------------|----------------|--------------------|-------------------------|--------------|------------|
| Engine | MAIN BEARINGS | | | | CONNECTING ROD BEARINGS | | |
| | Journal Diam. | Clearance | Thrust Bearing | Crankshaft Endplay | Journal Diam. | Clearance | Sideplay |
| 454" | ① 2.7485-2.7494" | ④ .0013-.0025" | No.5 | .006-.010" | 2.1985-2.1995" | .0009-.0025" | .013-.023" |
| | ② 2.7481-2.7490" | ③ .0024-.0040" | | | | | |
| | ③ 2.7478-2.7488" | | | | | | |

① - Journal no. 1

② - Journal nos. 2, 3 and 4.

③ - Journal no. 5.

④ - Journal nos. 1, 2, 3 and 4.

| VALVE SPRINGS | | | |
|---------------|-------------|-----------------|---------------|
| Engine | Free Length | PRESSURE (LBS.) | |
| | | Valve Closed | Valve Open |
| 454" | 2.12" | 74-86@1.88" | 228-312@1.38" |

| CAMSHAFT | | | |
|----------|----------------|-----------|-----------|
| Engine | Journal Diam. | Clearance | Lobe Lift |
| 454" | 1.9482-1.9492" | | .2343" |