

DANA/SPICER SEMI-FLOATING AXLES

International Harvester Jeep

NOTE — *DRIVE AXLE USAGE* — The Dana/Spicer model 44 drive axle is the only semi-floating Dana/Spicer drive axle used in light truck application. Some models may use other semi-floating drive axles, see Contents Page.

DESCRIPTION

The Dana/Spicer model 44 semi-floating drive axle is used as a rear drive axle only. The axle assembly has an integral differential carrier and an over-hung mounted drive pinion. The drive pinion depth, pinion bearing preload, and differential side bearing preload are all set or adjusted by shims. The Dana/Spicer model 44 drive axle assembly is also available with full-floating axles. See *Dana/Spicer Full-Floating Axles* in this Section.

AXLE RATIO & IDENTIFICATION

All Dana/Spicer drive axles have an integral carrier with a removable rear cover plate. The cover plate has a unique shape that allows positive identification of Dana/Spicer drive axles on any vehicle. See Fig. 1. The axle model is often cast on the differential housing, or it can be determined by measuring the diameter of the ring gear. See the following chart. To determine the drive axle ratio, refer to Drive Axle Ratio Identification in this Section.

Model Identification By Ring Gear Size

Ring Gear Diameter	Model Number
8.500	44-XX

REMOVAL & INSTALLATION

REAR AXLE SHAFTS & BEARINGS

NOTE — *Rear axle bearings used on International Harvester and Jeep models with Dana/Spicer semi-floating axles do not require an end play adjustment.*

Removal (International Harvester) — 1) Raise vehicle and support with floor stands. Remove wheel, brake drum retaining clips, and brake drum. **NOTE** — *If it is necessary to back off brake shoes to remove drum, be sure that automatic adjuster lever is held away from starwheel before rotating starwheel.* Remove bearing retainer bolts and pull axle shaft out from axle housing. If axle seems stuck, install wheel to flange and use wheel for leverage. **CAUTION** — *Do not strike axle shaft to free it.*

2) Using a suitable puller, remove bearing cup and oil seal from bore of axle housing. To remove bearing from axle, cut through bearing retaining ring with a cold chisel without nicking axle shaft. With retainer removed, press bearing off shaft. Remove outer oil seal and retainer plate from axle shaft. **CAUTION** — *Do not use heat from any source to remove retaining ring.*

Installation (International Harvester) — 1) If old bearing is to be reused and is still installed on axle shaft, it can be

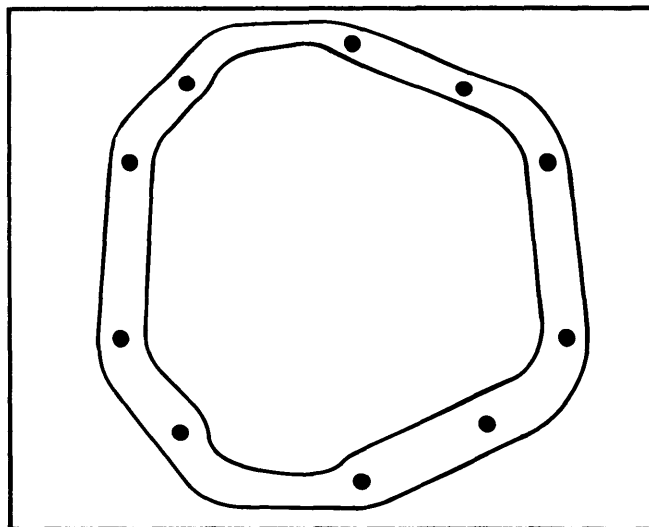

Fig. 1 Dana/Spicer Housing Cover Gasket for Identification Purposes

lubricated as follows: Push bearing retainer and seal towards flanged end of shaft being careful that seal does not come off machined part of shaft. Fill cavity between seal and bearing with grease. Wrap masking tape around seal and bearing to retain grease. With masking tape in place, pull seal up towards bearing, forcing grease into bearing. If grease does not appear at small end of rollers, repeat procedure. **CAUTION** — *Be sure that no grease is on flange side of seal.*

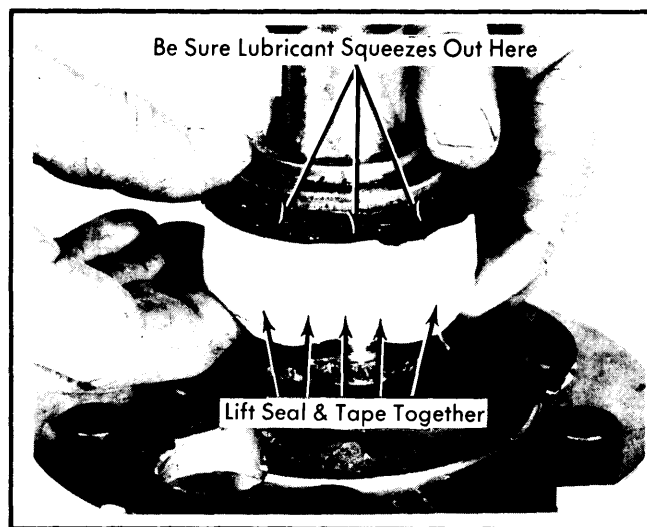

Fig. 2 Correct Procedure for Lubrication Bearing Installed on Axle Shaft

2) On disassembled axle, install retainer and carefully position seal on machined seat on axle. Press bearing onto shaft making sure that cup rib ring is towards flange end of shaft (see illustration). Press new bearing retainer ring on axle shaft with narrow end toward splined end of shaft. (Bearing and retainer can be pressed on at same time). Bearing and retainer must be pressed into seat on shaft so that a .0015" feeler gauge cannot be inserted between seat and bearing or between bearing and retainer.

DANA/SPICER SEMI-FLOATING AXLES (Cont.)

3) Install seal and bearing cup into axle housing if old bearing is being reused. Install seal only into housing if new bearing is used (cup was installed on shaft with cone). Install shaft in housing making sure that splines do not damage seal lip. Install backing plate mounting bolts and finger tighten. Tighten nuts evenly and alternately to specifications in 15 ft. lbs. increments. Install drum, retainer clips, and wheels. There is no axle shaft end play adjustment.

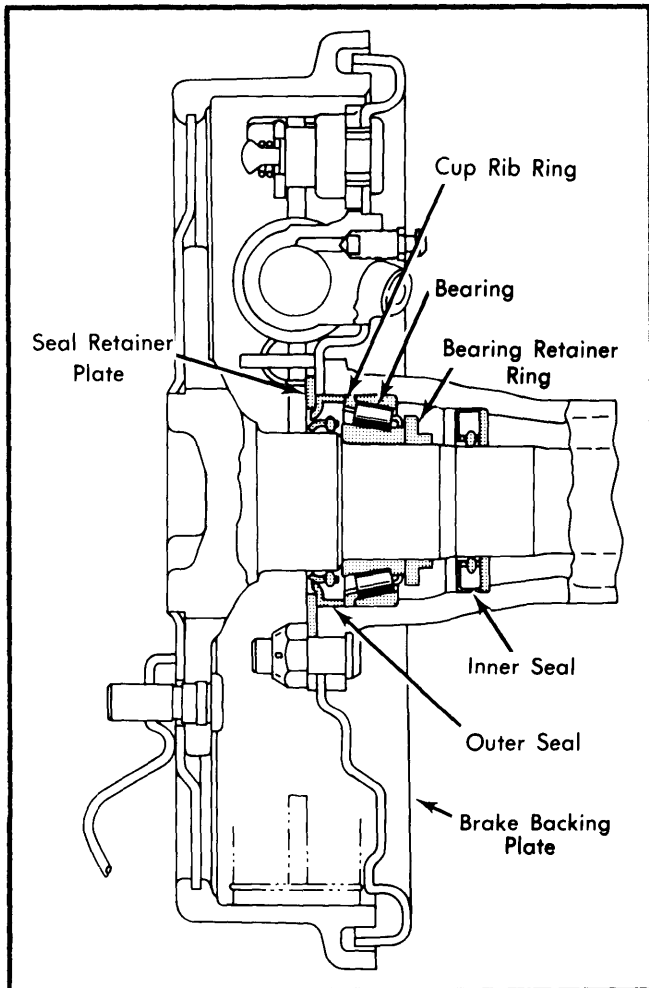

Fig. 3 Sectional View of Flanged Shaft End With Non-Adjustable Bearing

Removal (Jeep) — 1) Raise rear of vehicle and support with safety stands. Remove wheel and tire, and brake drum.

2) Remove brake backing plate and bearing retaining plate nuts through access hole in axle shaft flange.

3) Bolt a suitable adapter (J-21579) to lug bolts on axle shaft flange. Attach a slide hammer to adapter and remove axle shaft from housing.

4) Pry out axle shaft oil seal from axle housing.

5) Mount axle shaft in a vise. Drill a $\frac{1}{4}$ " hole in bearing retainer ring. Drill hole to a depth $\frac{3}{4}$ of ring thickness. Do not allow drill to contact axle shaft.

6) Place a chisel over drilled hole in ring. Using chisel, cut a deep groove in ring. This will enlarge ring and allow it to be removed from axle shaft.

NOTE — Do not heat retaining ring. Heat will transfer to bearing journal and weaken it.

7) Position a suitable support plate (J-23674) under bearing. Place bearing and support plate in a hydraulic press and remove bearing from axle shaft.

8) Cut through oil seal using a hacksaw. Remove seal and retainer plate. Inspect seal surface on axle shaft for damage. Repair any scratches with crocus cloth.

Installation (Jeep) — 1) Position retainer plate on axle shaft. Pack a suitable wheel bearing grease between oil seal lips.

2) Install oil seal on axle shaft. Make sure outer face of seal faces axle flange.

3) Position bearing on axle shaft. Make sure cup rib ring is facing axle flange. Install a new bearing retainer ring on axle shaft.

4) Using support plate used during bearing removal, press bearing and retainer ring on axle shaft at same time. Make sure bearing and ring are seated against axle shaft shoulder.

5) Install a new oil seal in axle housing tube. Slide axle shaft assembly into position in tube. Care must be taken not to damage seal lip.

6) Apply wheel bearing grease around outside of bearing before sliding into place. Tap flange with a rubber mallet to drive axle into place.

7) Install brake backing plate and retainer plate nuts and lockwashers. Install brake drum. Install wheel and tire and lower vehicle.

PINION FLANGE & SEAL

NOTE — Pinion seal can be serviced with axle assembly installed in vehicle.

Removal — Disconnect drive shaft and scribe a line down pinion shaft, flange, and nut. Remove nut and, using a suitable tool, remove flange. **CAUTION** — Do not hammer flange off. Damage to pinion gear, ring gear, and bearing could result. Pry seal from bore using care not to damage machined surfaces.

Installation — Lubricate cavity between seal lips with a high melting point lubricant. Install seal into bore making sure that it bottoms against shoulder. Place flange on shaft and draw it down with pinion nut. Tighten pinion nut to specifications.

CAUTION — Failure to tighten pinion nut to full specifications will result in flange or pinion shaft failure. Install drive shaft.

AXLE ASSEMBLY

Removal — Raise vehicle on hoist and support axle assembly to take weight off springs. Disconnect drive shaft at pinion flange and tie out of way. Remove hub and drum assembly.

DANA/SPICER SEMI-FLOATING AXLES (Cont.)

Disconnect vent tube (if equipped), and disconnect parking brake cable(s) and service brake hydraulic lines. Disconnect shock absorbers at axle brackets. Disconnect springs and remove axle.

Installation — Reverse removal procedure. Do not fully tighten shock absorbers nut until assembly is completed. Bleed hydraulic lines and adjust parking brake before moving vehicle.

OVERHAUL

DISASSEMBLY

NOTE — Axle housing does not need to be removed to overhaul assembly.

1) Remove axles and housing cover. Be sure that side bearing caps are marked so that they can later be installed in their original positions. Remove bolts and side bearing caps. Use a housing spreader to spread differential housing .015-.020". Use a dial indicator to measure spread. **CAUTION** — Do not spread housing more than .020". Permanent damage to housing could result. Carefully pry differential case out of housing. Be careful not to damage machined surface of housing. Remove spreader immediately to prevent possibility of carrier taking a set.

2) Remove bolts holding ring gear to differential, then tap ring gear from case with soft-faced hammer. With a small punch, drive out lock pin from differential case. Remove differential shaft and thrust block. Remove differential pinion gears and thrust washers.

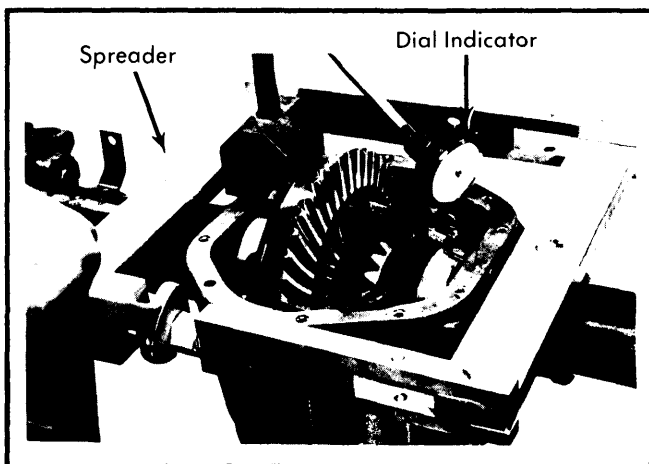

Fig. 4 Correct Procedure to Spread Carrier Housing

3) Remove pinion nut. With suitable puller, remove pinion flange. Using soft-faced hammer, drive pinion shaft out of housing. **NOTE** — Pinion bearing adjusting shims may remain on pinion shaft, stick to bearing, or fall loose. Collect them and save them for reassembly. From pinion shaft bore, remove oil seal and bearing cone. A baffle or an oil slinger may also be present; record the order in which they were removed so that they may be installed correctly. Discard seal. Remove inner bearing cone and press pinion bearing off pinion shaft.

4) Using a suitable puller, remove side bearings from differential case. Often during removal of side bearings, shims between bearings and differential case are mutilated. If so, shims must be individually measured and their thicknesses recorded, so that new shim packs can be secured.

REASSEMBLY & ADJUSTMENT

Case Assembly — 1) Place differential case in holding fixture or vise. Lubricate side and pinion gears and all thrust washers and install in case. Rotate side gears until holes in pinion gears and washers line up with holes in case. Install spacer block (if equipped) and differential pinion shaft. If old thrust washers are used, check for preload of side gears. Clearance between side gears and case should be .000-.006"; if not, shims can be installed (at least one on each side) or new thrust washers used. Install lock pin and peen over hole to retain pin. Inspect ring gear and case for burrs and nicks. Install ring gear and tighten bolts evenly.

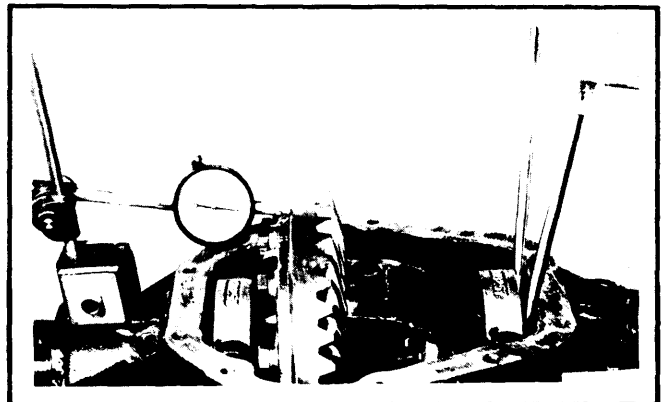

Fig. 5 Measuring Differential End Play With a Dial Indicator

2) Install differential side bearings. Assemble case in housing WITHOUT shims. Install bearing caps and tighten bolts just enough to seat bearing caps. Mount dial indicator to read at back of differential flange. Measure and record amount of side play of differential case by moving back and forth with a screwdriver (see illustration). The measurement will be used later to determine proper shim pack dimension. Remove case from housing.

Pinion Depth & Bearing Preload — 1) Pinion is adjusted by shims placed between inner bearing cup and housing, and by shims placed between pinion shaft shoulder and outer bearing. Shims behind inner bearing cup adjust position of pinion in relation to ring gear. Shims behind outer bearing adjust pinion inner and outer bearing preload.

2) If old pinion and ring gear assembly are used, proceed as follows: Install original shims and inner bearing cup. Install outer bearing cup. Press bearing cone onto pinion shaft and install shaft into housing. Install outer bearing cone, companion flange, and nut. Do not install outer shims or seal at this time. Tighten nut to obtain bearing preload of 10-30 ft. lbs. Use a suitable gauge to measure distance from ring gear center to machined button on end of pinion gear. Add or subtract shims from under inner bearing cup to obtain nominal dimension listed in specifications.

DANA/SPICER SEMI-FLOATING AXLES (Cont.)

3) If new pinion and ring gear assembly are to be installed, proceed as follows: Determine pinion depth adjustment figure (see illustration) of old and new pinions and find shim adjustment figure from chart. Adjust original shim pack accordingly and proceed as in step 2).

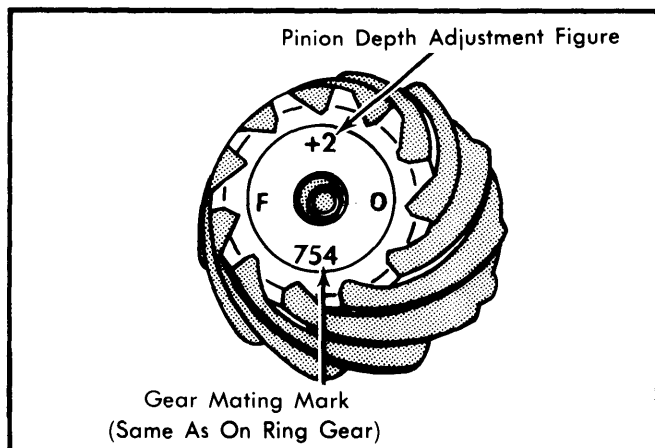

Fig. 6 Pinion Gear Markings Showing Depth Adjustment Figure

4) Remove pinion flange and nut, and remove front pinion bearing cone. Install original preload shim pack. Lubricate and install bearing cone. Install pinion flange and nut and tighten to specifications while rotating pinion shaft. Place housing in position so that pinion shaft is vertical, pointing up. With INCH lb. wrench rotate shaft through several revolutions to measure rotating torque. **NOTE** — Ignore torque needed to start shaft rotating. Check measurement against pinion bearing preload in specifications. To decrease preload, add shims; to increase preload; subtract shims. After adjustment is made, install oil seal and recheck pinion depth.

5) Front axles only: Check seals in axle housing bores. If condition is questionable, replace using suitable installer tool (see

illustration). **NOTE** — When installing front axle shafts be sure that these seals are not dislodged.

Side Bearing Preload — 1) With pinion installed in housing and depth and preload adjustments properly made, install differential case into housing and set dial indicator so that it reads at back of ring gear. Leave bearing cap bolts loose enough to allow movement of case. Insert screwdriver between bearing cap and housing at opposite end from ring gear. Jam case toward ring gear side and, with force still applied to case, set dial indicator to zero. Jam case the other way (making sure that ring and pinion gears mesh) and record reading. Repeat several times until readings are the same. This reading is amount of shims that will go between case and bearing on ring gear side. Install these shims.

2) From the figure originally recorded under Case Assembly, subtract amount of shims just installed on case. Add .015" for bearing preload and install new shim pack on end of case opposite ring gear.

Example: +.070" (Original Recorded Sideplay)
 −.032" (Sideplay With Pinion Installed)
 =.038" (Amount Left From Original Sideplay)
 +.015" (Additional Amount For Bearing Preload)
 =.053" (Amount Installed Opposite of Ring Gear)

3) Install spreader to housing, spread housing and install differential case. **NOTE** — Do not spread housing more than .020". Permanent damage to housing could result. Install differential assembly. Remove spreader and install bearing caps. Make sure that caps are in original position, then tighten caps evenly.

Backlash & Final Assembly — Mount dial indicator to housing and measure ring gear to pinion gear backlash in three places around ring gear (see specifications). Variation between readings should not exceed .002". Adjust to specifications by moving shims from one side of differential case to other, or by changing depth of pinion gear. Check tooth contact pattern (see Tooth Contact Pattern in this section). Install cover and tighten bolts to specifications.

PINION DEPTH SHIM ADJUSTMENT CHART									
Old Pinion	New Pinion								
	−4	−3	−2	−1	0	+1	+2	+3	+4
+4	+0.008	+0.007	+0.006	+0.005	+0.004	+0.003	+0.002	+0.001	0
+3	+0.007	+0.006	+0.005	+0.004	+0.003	+0.002	+0.001	0	−0.001
+2	+0.006	+0.005	+0.004	+0.003	+0.002	+0.001	0	−0.001	−0.002
+1	+0.005	+0.004	+0.003	+0.002	+0.001	0	−0.001	−0.002	−0.003
0	+0.004	+0.003	+0.002	+0.001	0	−0.001	−0.002	−0.003	−0.004
−1	+0.003	+0.002	+0.001	0	−0.001	−0.002	−0.003	−0.004	−0.005
−2	+0.002	+0.001	0	−0.001	−0.002	−0.003	−0.004	−0.005	−0.006
−3	+0.001	0	−0.001	−0.002	−0.003	−0.004	−0.005	−0.006	−0.007
−4	0	−0.001	−0.002	−0.003	−0.004	−0.005	−0.006	−0.007	−0.008

DANA/SPICER SEMI-FLOATING AXLES (Cont.)

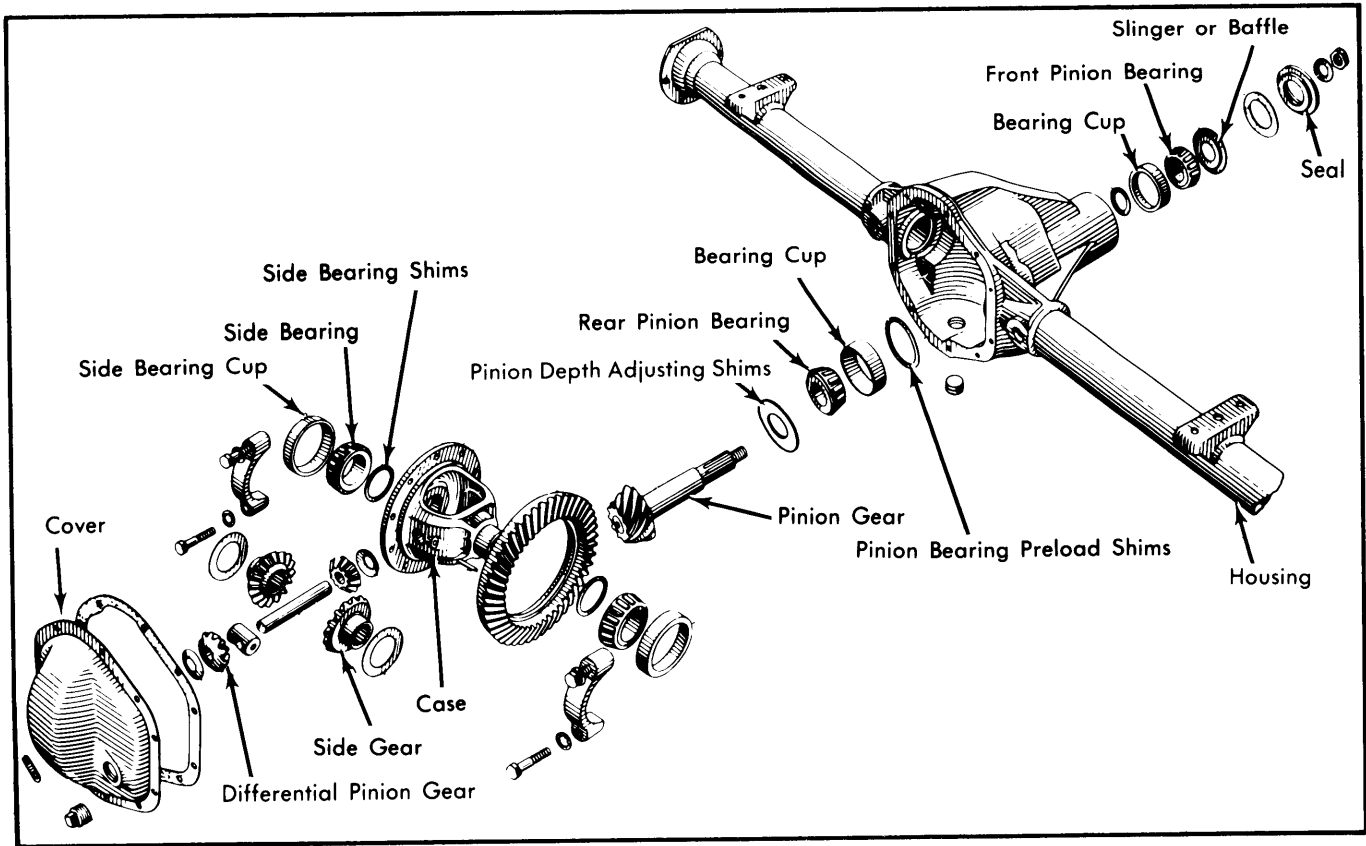

Fig. 7 Exploded View of Dana/Spicer Model 44 Semi-Floating Axle Assembly

AXLE ASSEMBLY SPECIFICATIONS (SEMI-FLOATING AXLES)

Application	Specification
Axle Shaft End Play	Non-Adjustable
Ring Gear Backlash005-.009"
Side Bearing Preload015"
Pinion Bearing Preload	
New Bearings	20-40 INCH Lbs.
Used Bearings	10-20 INCH Lbs.
Pinion Gear Depth (Nominal Dimension)	
Model 44 (8.500" Ring Gear).....	2.625"

TIGHTENING SPECIFICATIONS (SEMI-FLOATING AXLES)

Application	Ft. Lbs.
Pinion Shaft Flange Nut	210
Differential Side Bearing Cap Bolt	80
Ring Gear-to-Differential Case Bolt	55
Axle Shaft Retainer Bolt	30
Differential Housing Cover Bolt	20