

## GENERAL COOLING SYSTEM SERVICING

### DESCRIPTION

The basic liquid cooling system consists of a radiator, water pump, thermostat, cooling fan, pressure cap, heater (if equipped), various connecting hoses, and cooling passages in the block and cylinder head. In addition, many cars use a fan clutch, which may incorporate a thermostatic control, or a flexible blade fan, or both, to reduce noise and power requirements at higher engine speeds. Some models, with exhaust emission control, use a thermostatic vacuum switch to advance ignition timing in the event of overheating. As most new models require the use of a permanent (ethylene glycol) type anti-freeze, year round, coolant recovery systems are being used more commonly to prevent coolant loss.

### MAINTENANCE

#### DRAINING

Remove radiator cap, open heater control valve to maximum heat position (if equipped), open drain cocks or remove plugs in bottom of radiator and in engine block. In-line engines usually have one plug or cock, while V-engines will have two, one in each bank of cylinders.

#### CLEANING

A good cleaning compound will remove most rust and scale. Follow manufacturer's instructions in the use of the cleaner. If considerable rust and scale will have to be removed, flushing will be necessary. Also, clean radiator air passages by blowing out with compressed air from back to front of radiator.

#### FLUSHING

Back flushing is a very effective means of removing rust and scale from a cooling system. For best results the radiator, engine and heater core should be flushed separately. To flush radiator, connect flushing gun to water outlet of radiator and disconnect water inlet hose. Use a leadaway hose, connected to radiator inlet, to prevent flooding the engine. Use air in short bursts only, as a clogged radiator could be easily damaged. Continue flushing until water runs clear. To flush engine, first remove thermostat and replace housing. Connect flushing gun to water outlet of engine. Disconnect heater hoses from engine. Flush using short air bursts until water runs clean. Flush heater core as described for radiator. Make sure heater valve is set to maximum heat position before flushing heater.

#### REFILLING

Engine should be running while refilling cooling system to prevent air from being trapped in engine block. After system is full, continue running engine until thermostat is open, then recheck fill level. Do not overfill system. Refer to appropriate story for correct fill level.

### TESTING

#### THERMOSTAT

Visually inspect thermostat for corrosion and proper sealing. If this is satisfactory, suspend thermostat and a thermometer in a container of water. Do not allow either thermostat or thermometer to touch bottom of container as this concentration of heat could cause an incorrect reading. Heat water until ther-

mostat just begins to open and read temperature on thermometer. This is the initial opening temperature and should be within specifications. Then continue heating water until thermostat is fully open and note temperature. This is the fully opened temperature. If either reading is outside of limits, thermostat should be replaced, as it is not adjustable.

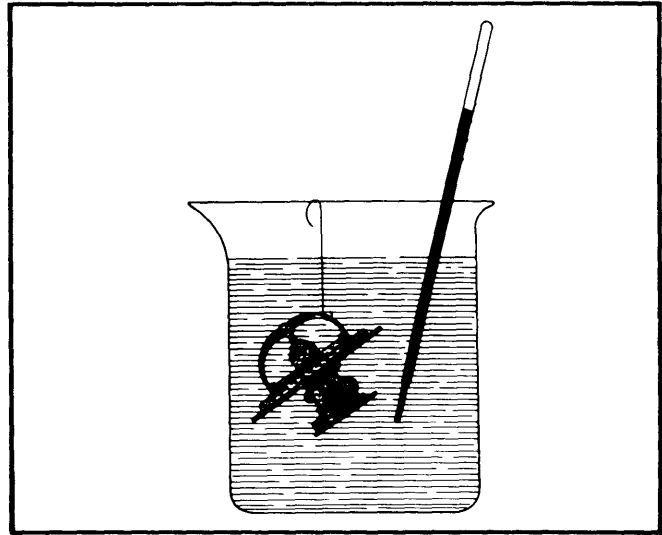

Fig. 1 Correct Procedure to Test Thermostat

#### PRESSURE TESTING

A pressure testing tool is used to test both radiator cap and complete cooling system. Test as follows, following tool manufacturer's instructions.

**Radiator Cap** — Visually inspect radiator cap, dip cap in water and connect to tester. Pump tester to bring pressure to upper limit of cap specifications. If cap fails to hold pressure within specifications, replace cap.

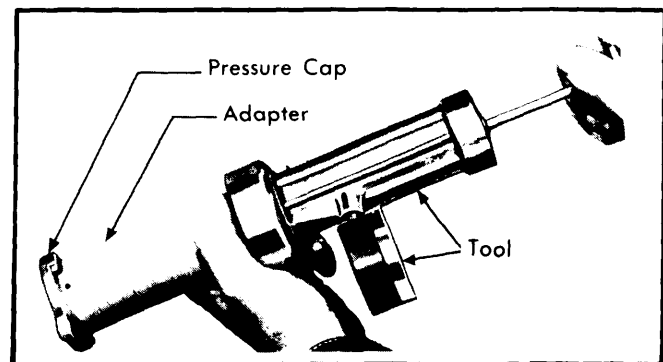

Fig. 2 Correct Procedure to Test Radiator Pressure Cap

**Cooling System** — With engine not running, wipe radiator filler neck seat clean. Fill radiator to correct level. Attach tester to radiator and pump until pressure is at upper limit of radiator rating. If pressure drops, inspect for external leaks. If no leaks are apparent, detach tester and run engine until normal operating temperature is obtained. Reattach tester and pump to about seven psi. Race engine, if needle on dial fluctuates it indicates a combustion leak.

# Engine Cooling Systems

## GENERAL COOLING SYSTEM SERVICING (Cont.)

**CAUTION** — Pressure may build up fast. Release any excess pressure above the upper limit of pressure cap specifications or cooling system damage may result.

If needle does not fluctuate, race engine a few more times and check for water at tailpipe. Excessive water would indicate a faulty head gasket, cracked block or cylinder head near exhaust ports. Next, remove oil dipstick and if water globules appear in the oil, a serious internal leak is indicated.

### ANTI-FREEZE CONCENTRATION

Test anti-freeze concentration using a suitable anti-freeze tester. The tester should have a temperature compensating feature, as failing to take temperature into consideration could cause an error as large as 30°F. Follow tester manufacturer's instructions for correct use of tester.

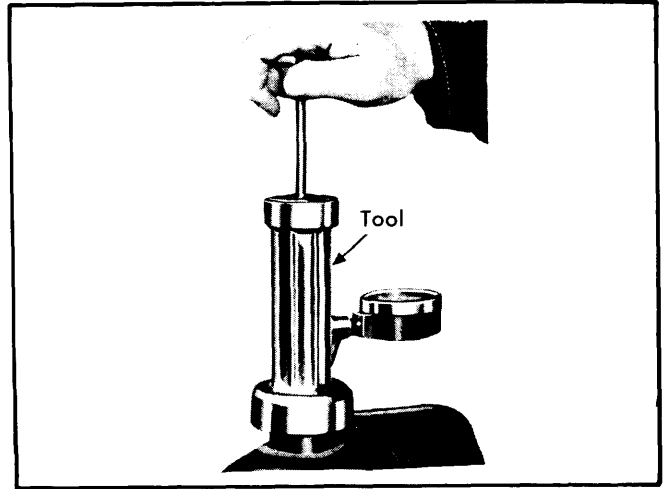

Fig. 3 Correct Procedure to Test Cooling System

## COOLANT RECOVERY SYSTEMS

### DESCRIPTION

A coolant recovery system differs from a normal cooling system in that an overflow bottle is connected to the radiator overflow hose. The overflow bottle is transparent or translucent to permit checking of coolant level without removing radiator cap. No adjustment or test is required beyond keeping vent hole or hose clean and checking pressure relief of radiator cap.

### OPERATION

As coolant temperature rises and pressure in system exceeds pressure relief valve of radiator cap, due to expansion of coolant, excess coolant flows into overflow bottle. As engine cools and coolant contracts, vacuum is formed in system, drawing coolant, stored in overflow bottle, back into radiator. As a result, in a properly maintained cooling system, the only coolant losses will be through evaporation.

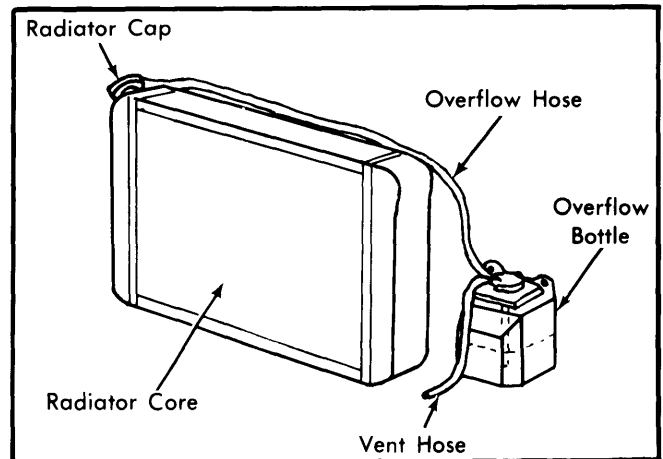

Fig. 1 Coolant Recovery System